



# TECHNIC

42009



42009



15 x

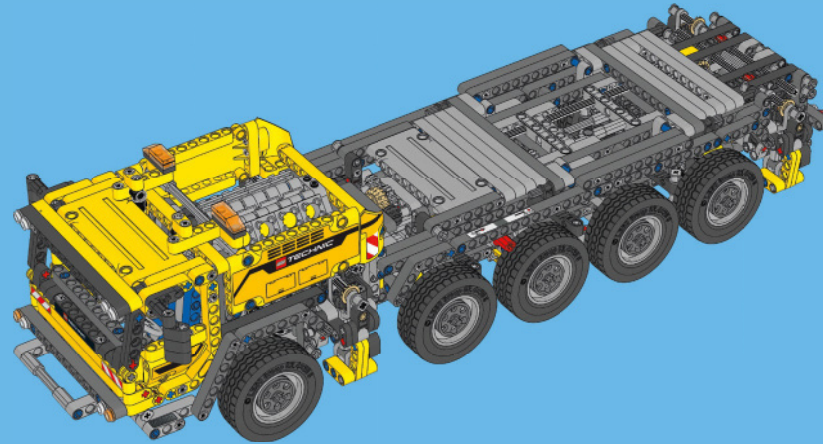

5 x

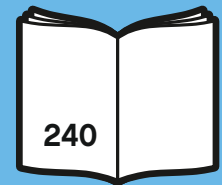
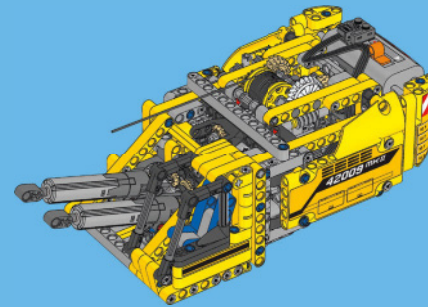
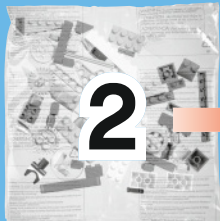

4 x

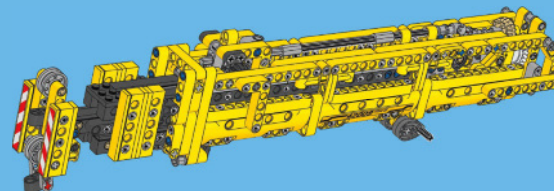
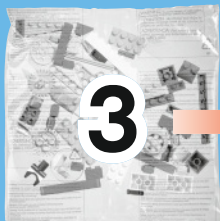





**1.5 V** LR 6 (AA)  
1:1

**6x**

## EN

### Important information about batteries

Never use different types of batteries together, or a combination of old and new batteries. Always remove the batteries if the product is not to be used for a long time or if the batteries have run down. Never use damaged batteries. Only use batteries of the type recommended, or a corresponding type. Insert the batteries so that the poles are correctly positioned. Rechargeable batteries must be recharged using the correct battery charger under the supervision of an adult. You cannot recharge batteries while they are still in the product, and you must never try to do so. Never attempt to recharge non-rechargeable batteries. Never short-circuit the battery holder.

## DE

### Wichtige Information zu Batterien

Benutzen Sie niemals unterschiedliche Arten von Batterien oder alte und neue gleichzeitig. Nehmen Sie stets die Batterien heraus, wenn mit dem Modell längere Zeit nicht gespielt wird oder wenn die Batterien leer sind. Verwenden Sie niemals beschädigte Batterien. Verwenden Sie ausschließlich empfohlene bzw. geeignete Batterien. Achten Sie beim Einsetzen der Batterien auf die richtige Polung. Wiederaufladbare Batterien sollten mit einem geeigneten Ladegerät aufgeladen werden – unter der Aufsicht eines Erwachsenen. Batterien können und sollten niemals aufgeladen werden, während sie sich im Modell befinden. Versuchen Sie unter keinen Umständen, „normale“ Batterien wiederaufzuladen. Schließen Sie das Batteriefach niemals kurz.

## FR

### Informations importantes concernant les piles

Ne jamais utiliser un mélange de différents types de piles, ou de piles neuves et de piles anciennes ou déjà utilisées. Toujours retirer les piles si le produit n'est pas utilisé durant une période prolongée ou si les piles sont vides. Ne jamais utiliser de piles endommagées. Utiliser uniquement des piles du type recommandé ou d'un type équivalent. En insérant les piles, respecter scrupuleusement le sens d'orientation des pôles (+/-). Les piles rechargeables doivent être rechargées en utilisant un chargeur de piles adéquat et sous la surveillance d'un adulte. Il est impossible de recharger les piles quand elles sont installées dans le produit. Ne jamais tenter de le faire. Ne jamais essayer de recharger des piles non-rechargeables. Ne jamais court-circuiter le compartiment des piles.

## IT

### Importanti informazioni sulle batterie

Non usare mai contemporaneamente batterie di tipo diverso o batterie nuove e usate insieme. Rimuovere sempre le batterie qualora il prodotto non venga utilizzato per periodi prolungati, oppure se le batterie sono esauste. Non utilizzare mai batterie danneggiate. Usare esclusivamente batterie del tipo raccomandato o un equivalente. Inserire le batterie avendo cura che la loro polarità sia corretta. Le batterie ricaricabili vanno ricaricate in un caricabatterie di tipo idoneo e con la supervisione di un adulto. Non è possibile e non bisogna mai tentare di ricaricare le batterie mentre queste sono inserite nel prodotto. Non tentare mai di ricaricare le batterie non ricaricabili. Non cortocircuitare mai il portabatterie.



## NL

Belangrijke informatie over batterijen

Gebruik nooit verschillende soorten of nieuwe en oude batterijen tegelijkertijd.Verwijder de batterijen altijd als je het product lange tijd niet wilt gebruiken of als de batterijen leeg zijn. Nooit beschadigde batterijen gebruiken. Uitsluitend batterijen van het aanbevolen of overeenkomstige type gebruiken. Leg de batterijen met de polen in de juiste richting. Oplaadbare batterijen moeten in een voor dit doel bestemde oplader en onder toezicht van een volwassene opnieuw worden opgeladen. Oplaadbare batterijen kunnen niet in het product worden opgeladen en je mag dit ook niet proberen te doen. Probeer nooit niet-oplaadbare batterijen op te laden. Nooit de batterijhouder kortsluiten.

## ES

Importante información sobre las baterías
No mezclar nunca diferentes tipos de baterías, ni utilizar baterías antiguas y nuevas a la vez. Sacar siempre las baterías, si el producto no se utiliza por un largo periodo de tiempo o si las baterías están desgastadas. No utilizar nunca baterías dañadas. Utilizar solo el tipo de baterías recomendado o uno correspondiente. Colocar las baterías de manera que los polos están en su posición correcta. Las baterías recargables deben cargarse con un cargador adecuado bajo la supervisión de un adulto. Las baterías no pueden, ni deben recargarse mientras permanecen en el producto. No intentar nunca recargar baterías no recargables. Asegurarse que no se produzca un cortocircuito en el porta baterías.

## DA

Vigtig information om batterier

Brug aldrig forskellige typer batterier sammen, eller nye og gamle batterier samtidig. Tag altid batterierne ud, hvis du ikke skal bruge produktet i længere tid, eller hvis batterierne er brugt op. Anvend aldrig beskadigede batterier. Der må kun anvendes batterier af samme eller tilsvarende type som anbefalet. Batterierne skal vende rigtigt når de i sættes. Genopladelige batterier skal oplades i en dertil beregnet oplader under opsyn af en voksen. Genopladelige batterier kan og må ikke forsøges opladet i produktet. Forsøg aldrig at genoplade ikke-genopladelige batterier. Kortslut aldrig batterikassens kontaktfleder.

## FI

Tärkeää tietoa paristoista

Älä koskaan käytä erityyppisiä paristoja yhdessä. Älä myöskään käytä samassa laitteessa sekä vanhoja että uusia paristoja. Poista paristot tuotteesta aina, kun se on pitemmän aikaa käyttämättä, tai kun paristot ovat vyhentyneet. Älä koskaan käytä viallisia paristoja. Käytä vain tuotteessa suositeltuja tai vastaavanyyppisiä paristoja. Aseta paristot siten, että navat osoittavat oikeaan suuntaan. Ladattavat paristot on ladattava oikeanlaisella laaturilla aikuisen valvonnassa.

Ne on poistettava tuotteesta lataamisen ajaksi.

Älä koskaan yritä ladata paristoja, joita ei ole tarkoitettu ladattaviksi. Älä koskaan aiheuta oikosulkua pariston kosketintien välillä.

## SV

Viktig information om batterier

Använd aldrig olika sorters batterier samtidigt, och inte heller en kombination av gamla och nya batterier. Ta alltid ur batterierna om produkten under en längre tid inte ska användas eller om batterierna är slut. Använd aldrig skadade batterier. Använd bara batterier av den typ som rekommenderats, eller av en motsvarande typ. Sätt in batterierna så att polerna hamnar i rätt läge. Laddningsbara batterier måste laddas med rätt slags batteriladdare och under en vuxens översyn. Du kan inte ladda batterierna medan de fortfarande sitter i produkten, och du får heller aldrig försöka göra det. Försök aldrig ladda icke laddningsbara batterier. Kortslut aldrig batteriutrymmets kontaktytor.

## PT

Informações importantes acerca das pilhas
Nunca use tipos diferentes de pilhas em conjunto, nem uma combinação de pilhas velhas e novas. Retire sempre as pilhas se o produto não vai ser utilizado durante muito tempo ou se as pilhas se estiverem gastas. Nunca use pilhas danificadas. Use apenas pilhas do tipo recomendado ou de um tipo correspondente. Introduza as pilhas de forma a que os seus pólos fiquem correctamente posicionados. Pilhas recarregáveis deverão ser recarregadas utilizando o recarregador de pilhas correcto sob a supervisão de um adulto. Não é possível recarregar pilhas recarregáveis enquanto elas ainda se encontram dentro do produto, e nunca devem ser feitas tentativas nesse sentido. Nunca tente recarregar pilhas não recarregáveis. Nunca faça curto-circuito do compartimento das pilhas.

## EL

Σημαντικές πληροφορίες για τις μπαταρίες
Μη χρησιμοποιείτε ποτέ διαφορετικούς τύπους μπαταριών, ή παλιές και καινούριες μπαταρίες μαζί. Βγάζετε πάντα τις μπαταρίες αν δεν χρησιμοποιήσετε το προϊόν για αρκετό καιρό ή αν οι μπαταρίες έχουν αδειάσει. Ποτέ μη χρησιμοποιείτε χαλασμένες μπαταρίες. Χρησιμοποιείτε μόνο μπαταρίες του συνιστούμενου τύπου, ή αντίστοιχου τύπου. Βάλτε τις μπαταρίες με την σωστή πολικότητα. Θα πρέπει να φορτίσετε τις επαναφορτιζόμενες μπαταρίες χρησιμοποιώντας τον κατάλληλο φορτιστή μπαταριών υπό την επίβλεψη ενός ενήλικου. Δεν μπορείτε να επαναφορτίσετε τις μπαταρίες όταν αυτές βρίσκονται μέσα στο προϊόν, και ποτέ μη επιχειρήσετε να κάνετε κάτι τέτοιο. Μη επιχειρήσετε ποτέ να επαναφορτίσετε μη επαναφορτιζόμενες μπαταρίες. Ποτέ μη βραχυκυκλώνετε τη θήκη των μπαταριών.

## JA

電池の取り扱いに関する注意

異なるタイプの電池や、古い電池と新しい電池を混ぜて使用しないで下さい。長時間商品を使用しない時や電池が切れた時は、必ず電池を取り外してください。電池は損傷されている種類が、もしくは反対側の種類のみを使用してください。電極を接触させて正しく方向に電池を入れてください。充電電池を使用する際は保護者の監督の元、正しく充電をして使用してください。商品の中に入れたまま電池を充電することは絶対に避けてください。充電ではない電池を充電したり、電極をショートさせたりしないでください。

## ZH

電池使用須知

切勿將不同種類的電池一起使用，亦不要把舊電池與新電池混合使用。如有一段長時間不會使用本產品或電池已耗盡，請把電池拆除。切勿使用已損壞之電池。只可使用建議中之電池型號，或其他兼容式型號。請根據指示安裝電池。

你可以使用充電的循環電池，但必須採用適當的充電器，並在成年人的指導下方可進行充電。電池仍在產品內是不能充電的，請勿強行嘗試。切勿試圖為非循環電池充電。亦切勿自行接駁電池箱的兩極，以免產生短路。

## KO

건전지 사용주의 사항

다른 전지끼리, 또는 새 전지와 구 전지를 혼용해서 사용하지 마십시오. 장기간 제품을 사용하지 않을 경우에는 전지를 제품에서부터 제거해 주십시오. 재사용가능전지(rechargeable battery)는 어린이의 통제 밖에 충전이 이루어져야 합니다. 또한 재사용가능전지(rechargeable battery)는 제품 안에서 충전될 수 할 없으므로, 절대로 충전해서는 안됩니다. 그리고, 충전가능전지(rechargeable battery)가 아닌 전지로 충전해서는 안됩니다.

## RU

Необходимая информация об элементах питания
Ни в коем случае не используйте одновременно элементы питания различных типов, а также элементы питания с разным сроком годности. В обязательном порядке вынимайте элементы питания из терминалов в случае, если вы не пользуетесь прибором в течение долгого времени либо в случае, если в элементах питания закончился заряд. Ни в коем случае не используйте поврежденные элементы питания. Используйте только рекомендуемые элементы питания, либо элементы питания соответствующего типа. Установите элементы питания, соблюдая указанную полярность. Аккумуляторные элементы питания должны подзаряжаться в соответствующем зарядном устройстве под наблюдением взрослого. Ни в коем случае не пытайтесь подзаряжать элементы питания, находящиеся в приборе. Ни в коем случае не пытайтесь подзаряжать непрезаряжаемые элементы питания. Ни в коем случае не пытайтесь замкнуть полюса в устройстве для элементов питания.

## PL

Ważne informacje dotyczące baterii

Nigdy nie należy stosować razem różnych rodzajów baterii ani stosować równocześnie starych i nowych baterii. Jeżeli produkt nie jest używany przez dłuższy czas lub jeżeli baterie się wyczerpały, należy wyjąć baterie. Nigdy nie należy stosować uszkodzonych baterii. Należy stosować wyłącznie zalecany rodzaj baterii lub rodzaj mu odpowiadający. Przy wkładaniu baterii należy zwrócić uwagę na właściwe położenie biegunów. Baterie akumulatorowe należy ładować w odpowiedniej ładowarce pod nadzorem osoby dorosłej. Nie można naładować baterii bez wyjęcia ich z produktu i nigdy nie należy tego próbować. Nigdy nie należy próbować ładowania baterii jednorazowych. Nigdy nie należy doprowadzać do zwarcia w gnieździe baterii.

## CZ

Důležitá informace o bateriích
Nikdy nepoužívejte najednou různé typy baterií nebo kombinaci starých a nových baterií. Nebudeďte výrobek dělit dobu používat nebo jsou-li baterie vybité, vždy je vyjměte z výrobku. Nikdy nepoužívejte poškozené baterie. Používejte pouze doporučené nebo odpovídající typy baterií. Baterie instalujte se správnou orientací pólů. Nabíjecí baterie musí být nabity ve vhodné nabíječce pod dohledem dospělé osoby. Nabíjecí baterie nelze nabíjet. jsou-li umístěny ve výrobku, a nesměte se o to ani pokoušet. Nikdy se nesnažte nabíjet baterie, které nejsou nabíjecími. Nikdy nezkratujte kontakty v prostoru pro baterie.

## SK

Dôležitá informácia o batériách

Nikdy nepoužívajte naraz odlišné typy batérií ani nekombinujte staré batérie s novými. Batérie vždy vyberte, ak sa výrobok nebude dlhšie používať, alebo ak sa batérie vybili. Nikdy nepoužívajte poškodené batérie. Používajte len odporúčané alebo zodpovedajúce typy batérií. Batérie vkladajte so správnou orientáciou pólou. Dobíjateľné batérie sa musia nabíjať v vhodnom nabíjači pod dozorom dospeléj osoby. Dobíjateľné batérie sa nesmú nabíjať, ak sú umiestnené vo výrobku, a nesmiete sa o to ani pokúšať. Nikdy sa nesnažte nabíjať batérie, ktoré nie sú dobíjateľné. Nikdy neskratuje kontakty v priestore pre batérie.

## HU

Fontos tudnivalók az elemekről

Soha ne használjunk különböző típusú elemeket, illetve ne használjunk új és használt elemet egyszerre. Mindig távolítsuk el az elemeket, ha a készüléket előre láthatóan hosszú ideig nem fogjuk használni, vagy ha az elemek lemerültek. Soha ne használjunk megromlódott elemet. Csak az ajánlott típusú, vagy annak megfelelő elemet használjuk. Az elemeket a polaritásuknak megfelelő módon helyezük be. Az akkumulátorokat csak a megfelelő akkumulátortöltővel szabad feltölteni, egy felnőtt segítő felügyelete mellett. Az akkumulátorokat nem tölthetjük fel úgy, hogy azok a termékben vannak, ezt meg sem szabad próbálnunk. Soha ne próbáljunk meg feltölteni a nem tölthető elemet. Soha ne hozzunk létre rövidzárlatot az elemtartó kivezetési között.

## UA

Необхідна інформація про батареїки

Ніколи не використовуйте одночасно батареїки різних типів або батареїки з різним строком вживання. Обов'язково вилучайте батареїки з прибору якщо довготочасно не користуєтесь їм, або якщо в батареїйках вже скінчився заряд. Ніколи не використовуйте пошкоджені батареїки. Використовуйте батареїки лише рекомендованого або відповідного типу. Вставляйте батареїки, враховуючи задану полярність. Акумуляторні батареїки повинні заряджатись у відповідному зарядному приладі під наглядом дорослого. В будь-якому випадку не намагайтесь підзарядити батареїки, що знаходяться в приборі. В будь-якому випадку не намагайтесь підзарядити батареїки, що не підлягають підзарядці. В будь-якому випадку не намагайтесь зробити коротке замикання в приладі для батарей.

## HR

Ważne informacje o baterijama

Nikada ne koristite različite vrste baterija zajedno, kao ni ti kombinaciju starih i novih baterija. Uvijek izvadite baterije ako uređaj neće biti korišten duže vrijeme ili ako su baterije prazne. Nikada ne koristite oštećene baterije. Upotrebljavajte samo preporučenu vrstu baterija ili njima ekvivalentni tip. Umetnite baterije tako da su im polovi ispravno orijentirani. Baterije koje se mogu puniti moraju biti punjene u odgovarajućem punjaču baterija pod nadzorom odrasle osobe. Ne možete puniti baterije dok su umetnute u uređaj i to nikada niti ne pokušavajte. Nikada ne pokušavajte napuniti baterije koje se ne mogu puniti. Nikada kratkim spojem ne spajate polove baterija.

## SR

Важне информације о батеријама

Никада не користите различите типове батерија заједно, и не комбинирате старе батерије са новима. Увек извадите батерије уколико производ нећете користити дуже време или ако су се батерије испразниле.

Никада не употребљавајте оштећене батерије. Користите искључиво тип батерија који се препоручује или одговарајућу замену. Приликом постављања батерија pazите да полови буду правилно оријентисани. Батерије на пуњење се морају пунити уз употребу одређеног пуњача и под надзором одрасле особе. Батерије се не могу пунити док су у производу, и то не сматте ни да покушавате. Никада не покушавате да напуните батерије које се не пуне. Никада не преспајате полове кућишта за батерије.



## SL

Pomembna informacija o baterijskih vložkih  
Nikoli ne uporabite različne vrste baterijskih vložkov skupaj ali pa nove vložke skupaj z rabljenimi. Če so se baterijski vložki izpraznili ali če izdelka ne boste uporabljali dlje časa, morate vložke vedno odstraniti. Nikoli ne uporabite poškodovanih baterijskih vložkov. Uporabite samo priporočen tip baterijskih vložkov ali enakovredne vložke. Baterijske vložke vstavite tako, da sta pola plus in minus pravilno usmerjena. Baterijske vložke za ponovno polnjenje morajo otroci polniti z ustreznim polnilcem samo pod nadzorom odrasle osebe. Pred polnjenjem morate vložke vedno izvléči iz igrače. Nikoli ne smete polniti baterijskih vložkov, medtem ko so še vedno v igrački. Nikoli ne poskušajte polniti baterijske vložke, ki niso namenjeni za ponovno polnjenje. V prostoru za baterijske vložke ne smete nikoli povzročiti kratkega stika.

## RO

### Informații importante cu privire la baterii

Nu folosiți niciodată împreună tipuri diferite de baterii și nici combinații de baterii noi și vechi. Îndepărtați întotdeauna bateriile dacă produsul nu este folosit timp îndelungat sau dacă bateriile s-au epuizat. Nu folosiți niciodată baterii deteriorate. Folosiți numai baterii de tipul recomandat, sau de un tip corespunzător. Introduceți bateriile astfel ca poliul să fie în poziție corectă. Bateriile reincărcabile trebuie reincărcate utilizând un dispozitiv de încărcare adecvat, sub supravegherea unui adult. Bateriile nu pot fi reincărcate cât timp sunt încă în produs, și nu încercați niciodată să le încărcăți astfel. Nu încercați niciodată să reincărcăți baterii care nu sunt reincărcabile. Nu scurtcircuitați niciodată bornele suportului bateriei.

## BG

Важна информация за батериите  
Не използвайте различни типове батерии едновременно, нито комбинация от стари и нови батерии. Винаги изваждайте батериите, ако izdelieto няма да се използва продължително време или ако батериите са се изтозили. Не използвайте повредени батерии. Използвайте само батерии от препоръчания тип или съответстващ на него тип. Поставете батериите така, че полюсите да са разположени правилно. Акумуляторните батерии трябва да се зареждат с подходящо зареждащо устройство под надзора на възрастни. Батериите не могат да се зареждат, докато са поставени в izdelieto, така че не трябва да се опитвате да правите това. Не се опитвайте да зареждате батерии, които не са акумулаторни. Не свързвайте в късо съединение клемите на батериите.

## LV

### Svarīga informācija par barošanas elementiem

Nekad vienlaikus nelietojiet dažādu tipu, kā arī jaunus un vecus barošanas elementus. Arvien izņemiet barošanas elementus, ja tie izlādējušies vai to darbinātāis izstrādājums ilgāku laiku netiek lietots. Nekad nelietojiet bojātus barošanas elementus. Lietojiet tikai ieteicamā tipa barošanas elementus vai tiem atbilstošus analogus. Ievietojot barošanas elementus, jāievēro pareiza to pievienojuma polaritāte (+/-). Uzlādējamu barošanas elementu lādēšanai jāizmanto atbilstošs barošanas elementu lādētājs, uzlādēšana jāveic pieaugušo uzraudzībā. Izstrādājumā ievietotus barošanas elementus uzlādēt nav iespējams, mēģinājumi to darīt nav pieļaujami. Nekad nemēģiniet uzlādēt neuzlādējamus barošanas elementus. Nekad nepieļaujiet īsslēgumu starp barošanas elementu tīpnes kontaktiem.

## ET

### Oluline teave patareide kohta

Mitte kunagi ära pane mänguasja sisse koos erinevat tüüpi patareisid, samuti vanu ja uusi patareisid. Kui mänguasja ei kasutata pika aja jooksul, võta patareid sellest välja. Ka tühjaksaanud patareid tuleb mänguasjast välja võtta. Ära kasuta kahjustatud patareisid. Kasuta ainult ettenähtud tüüpi või neile samaväärseid patareisid. Pane patareid mänguasja sisse nii, et pluss- ja miinuskl emmi asend oleks õige. Akusid tuleb laadida ainult nendele ettenähtud akulaadija abil täiskasvanu järelevalve all. Akusid ei saa laadida sel ajal, kui need on mänguasja sees. Ära kunagi püüa nii teha. Ära mitte kunagi proovi akulaadijaga laadida talvisi patareisid. Patareipesa klemmide vahel ei tohi tekkida lühis.

## LT

### Svarbi informacija apie elementus

Nesinaudokite vienu metu skirtingų tipų elementais, taip pat su naujais elementais nenaudokite senų elementų. Išimkite elementais iš įdėklo, jeigu nesinaudosite gaminiu ilgą laiką arba jeigu elementais išsiseikvojo. Nesinaudokite sugadintais elementais. Naudokitės tik rekomenduojamo arba atitinkamo tipo elementais. Įdėkite elementais taip, kad atitiktų teigiami ir neigiami poliū. Akumuliatorinius elementais galima įkrauti tik tinkamu elementų krovikliu, priziūrint suaugusiesiems. Elementų negalima įkrauti, neišėjus jų iš įdėklo, ir nebandykite to daryti. Nebandykite įkrauti neakumuliatorinio tipo elementų. Nedarykite trumpo jungimo elementų įdėkle.

## TR

### Piller hakkında önemli bilgiler

Hicbir zaman değışik tipe pilleri ya da eski pillerle yeni pilleri bir arada kullanmayın. Pili ürün uzun süre kullanılmayacaksa ya da piller bitmişse, pilleri çıkarın. Hicbir zaman zedelemiş piller kullanmayın. Yalnız önerilen tipe piller ya da bunların dengi olan pilleri kullanın. Pilleri kutularını dogru konumda olacak şekilde yerleştirin. Bitince yeniden doldurulabilen piller dogru pil doldurucuyu kullanarak, bir yetișkinin denetiminde doldurulmalıdır. Doldurulabilir pilleri ürünün içinden dolduramazsınız; Doldurulabilir pilleri ürünün içinden dolduramazsınız; Doldurulamaz tip pilleri yeniden dolduramazsınız. Hicbir zaman pil kutusuna ksa devre yaptırılmayın.

## ID

### Informasi penting tentang baterai

Jangan gunakan baterai yang jenisnya berlainan, atau mencampur baterai lama dan baterai baru, Lepas baterai jika produk tidak akan digunakan untuk waktu lama atau jika baterai sudah lemah. Jangan gunakan baterai yang rusak. Gunakan jenis baterai yang dianjurkan atau yang sejenis. Masukkan baterai dengan posisi kutub yang tepat. Baterai isi ulang harus diisi ulang dengan charger baterai yang sesuai dan di bawah pengawasan orang dewasa, Anda tidak dapat mengisi ulang baterai saat masih terpasang di dalam produk, dan jangan pernah coba melukukannya. Jangan pernah coba mengisi ulang baterai biasa. Jangan pernah membuat arus pendek pada dudukan baterai.



EN Protect the environment by not disposing of this product with your household waste (2002/96/EC). Check with your local authority for recycling advice and facilities.

DE Schützen Sie die Umwelt und entsorgen Sie dieses Produkt nicht mit Ihrem Hausmüll (2002/96/EC). Informationen zu Recycling-Möglichkeiten erhalten Sie bei den örtlichen Behörden.

FR Protégez l'environnement : ne jetez pas ce produit avec vos autres déchets ménagers (Directive européenne 2002/96/EC). Contactez les autorités locales pour obtenir des informations sur le recyclage et connaître les points de collecte.

IT Proteggi l'ambiente! Non smaltire questo prodotto con i rifiuti domestici (2002/96/EC). Per consulenza sul riciclaggio dei rifiuti e le strutture di riciclaggio, rivolgersi alle proprie autorità locali.

NL Bescherm het milieu: gooi dit product niet samen met het andere huishvuil weg (2002/96/EC). Raadpleeg de plaatselijke instanties voor locaties van milieustations en advies over hergebruik.

ES Proteja el medio ambiente no desahaciéndose de este producto junto con sus residuos domésticos (2002/96/EC). Solicite a su autoridad local consejos e información sobre instalaciones de reciclado.

DA Beskyt miljøet! Smid ikke dette produkt ud sammen med husholdningsaffaldet (2002/96/EF). Få vejledning om genbrug og genbrugsstationer hos din kommune.

FI Tämä tuote on hävitettävä ympäristönsuojelun vuoksi asianmukaisesti talousjätteistä erillään (2002/96/EC). Tietoja kierrätyspisteiden sijainnista saa kunnan tai kaupungin teknisestä virastosta.



SV Skydda miljön genom att inte kasta denna produkt bland ditt hushållsavfall (2002/96/EC). Kontakta din kommun för frågor om återvinning och miljöstationer.

PT Proteja o ambiente não eliminando este produto com o seu lixo doméstico (2002/96/CE). Consulte as autoridades locais para informação sobre reciclagem e sistemas de recolha.

EL Προστατέψτε το περιβάλλον. Μην πετάτε αυτό το προϊόν μαζί με τα συνηθισμένα οικιακά απορρίμματα (2002/96/EC). Επικοινωνήστε με τις τοπικές αρχές σχετικά με συμβουλές και εγκαταστάσεις ανακύκλωσης.

PL Aby chronić środowisko naturalne, nie należy wyrzucać tego produktu wraz z odpadkami z gospodarstwa domowego (2002/96/WE). W celu uzyskania wskazówek dotyczących recyklingu oraz adresów zakładów należy skontaktować się z lokalnym urzędem.

CZ Nevylahzujte tento produkt do domácího odpadu, chrāňte životní prostředí (2002/96/EC). Zjistěte si prosím u místních úřadů možnosti recyklace a dostupná zařízení.

SK Nevylahzujte tento produkt do domácího odpadu, chrāňte životné prostredie (2002/96/EC). Zistite si prosím na miestnych úradoch možnosti recyklácie a dostupné zariadenia.

HU Környezetét óvja, ha ettől a termékétől nem a háztartási hulladékkal együtt válik meg (2002/96/EC). Érdéklődjék a lakóhelyéhez közel eső hatóságánál az újrahazsnosítás módjáról és lehetőségéről.



SL Zaščitite okolje! Okolje varujte tako, da tega izdelka ne zavržete skupaj z gospodinjiskimi odpadki (v skladu z direktivo 2002/96/ES). Pri krajevni upravi preverite, kakšne možnosti in kateri obrati za recikliranje obstajajo v vaši okolici.

LV Lai saudzētu vidi, neizmetiet šio izstrādājumu kopā ar sadzives atkritumiem (2002/96/EC). Vērsieties vietējās varas iestādēs, lai noskaidrotu, kur un kā tas nododams pārstrādei.

ET Keskkonda saate kaitsa nii, et ei kõrvalda seda toodet koos olmejäätmetega (2002/96/EÜ). Nõuandeid toote taaskasutusse võtmise ja ümbertöötlemispunktide kohta saate asjaomaset kohalikult asutuselt.

LT Saugokite aplinką – nemeskite šio produkto kartu su buitiniems atliekomis (2002/96/EB). Atsiūvelkite į savo vietos valdžios rekomendacijas dėl pakartotinio panaudojimo ir sąlygas.

ID Jagalah lingkungan dengan tidak membuang produk ini bersama sampah rumah tangga Anda (2002/96/EC). Periksa peraturan pemerintah setempat tentang saran dan fasilitas daur ulang.



- 3x 6013937
- 15x 6013938
- 7x 4666579
- 11x 4514554
- 10x 4666999
- 3x 4207456
- 17x 4565452
- 11x 4514555
- 2x 4234429
- 76x 4142865
- 8x 4513174
- 2x 4270473
- 3x 4278957
- 4x 6036545
- 6x 4158923
- 18x 4143005
- 113x 4206482
- 214x 4514553

- 3x 6036892
- 8x 4187122
- 18x 4153707
- 14x 4142133
- 15x 4495934
- 12x 4187136
- 15x 6028107
- 1x 4522935
- 10x 4542579
- 6x 6022952
- 4x 6038636
- 2x 4558879
- 2x 6005195

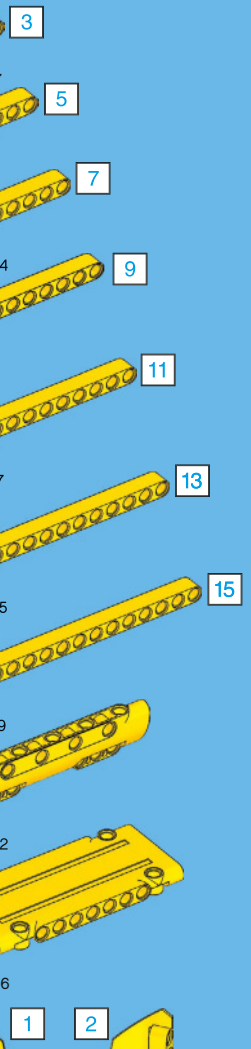

- 6x 389424
- 6x 366624
- 4x 663624
- 19x 4141628
- 14x 4144022
- 4x 4111996
- 15x 4173666
- 12x 4175441
- 22x 4107823
- 20x 4199345
- 15x 4503425
- 6x 6010863
- 2x 4494224
- 8x 4112203
- 9x 4107066
- 35x 4239601
- 8x 4526983

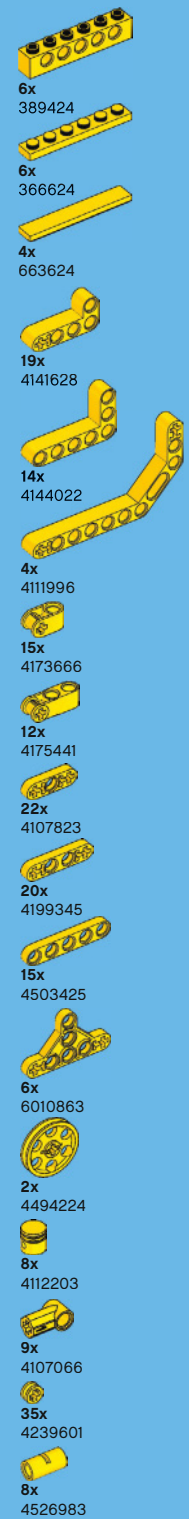

- 51x 4173668
- 10x 6006140
- 21x 4173970
- 23x 6007966
- 8x 4128557
- 4x 6010864
- 12x 6030286
- 3x 4563044
- 4x 4558692
- 1x 4540065
- 2x 4144023
- 16x 4164133
- 20x 4107828
- 3x 362326
- 2x 302126
- 5x 243126
- 11x 416226

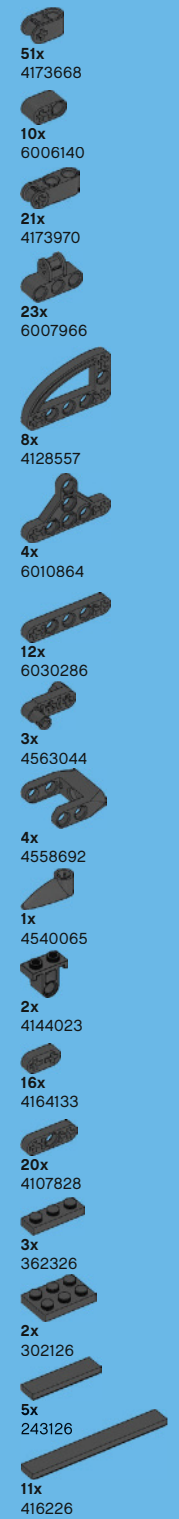

- 1x 370026
- 1x 273026
- 9x 370326
- 4x 4120017
- 2x 4142823
- 2x 4142135
- 1x 4495935
- 15x 4645732
- 11x 4542573
- 12x 4540906
- 25x 370526
- 8x 370626
- 3x 370726
- 7x 373726
- 3x 370826
- 5x 6043747
- 1x 4233937

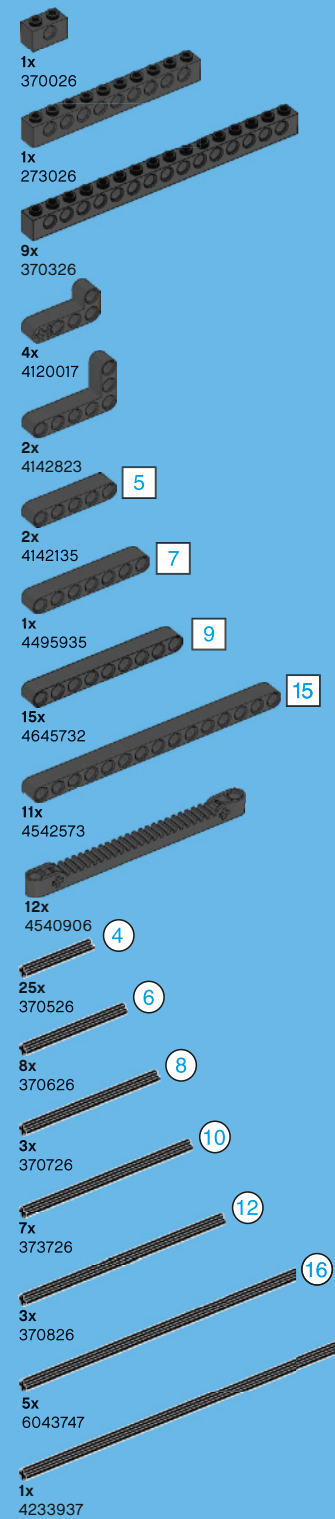

- 14x 4184169
- 495x 4121715
- 35x 4560174
- 10x 4107085
- 2x 4107084
- 23x 4177431
- 1x 4177430
- 5x 4246901
- 10x 4547373
- 8x 3005740
- 3x 3005741
- 2x 6031821
- 2x 4244369
- 2x 4280341
- 2x 4541710
- 4x 4222960





- 28x 4560177 **4**
- 11x 4508553 **5,5**
- 13x 4499858 **8**
- 19x 6012451
- 16x 4237267
- 3x 4514558
- 1x 4525184
- 10x 4587275
- 4x 4210656
- 2x 4210638
- 2x 4210668
- 45x 4495931 **7**
- 28x 4603472 **11**
- 18x 4542576 **15**

- 11x 4552349
- 1x 4210655
- 4x 4210759
- 4x 6005331
- 2x 4528038
- 2x 4205761
- 8x 4234251
- 8x 6000018
- 3x 4211609
- 21x 4211610
- 12x 4211713
- 4x 4211561
- 10x 4225033
- 8x 4296059

- 3x 4558690
- 27x 4640536
- 1x 4580510
- 3x 6044729
- 10x 4551421
- 25x 4211655 **3**
- 24x 4211651 **5**
- 32x 4522934 **13**
- 62x 4211815 **3**
- 29x 4211639 **5**
- 7x 4211805 **7**
- 10x 4535768 **9**
- 7x 4539880
- 2x 4540797
- 1x 4621555

- 8x 4211889
- 4x 4211880
- 1x 4211714
- 47x 6004888
- 16x 4211621
- 10x 4211450
- 2x 4211510
- 14x 4211567
- 68x 4211622
- 5x 4211758
- 8x 4211807
- 4x 4211553
- 32x 4512360
- 2x 4278756
- 64x 4211865
- 2x 4525904

- 2x 4528332
- 1x 6043879
- 1x 4624645
- 4x 4612100
- 2x 4638507
- 1x 4506078
- 1x 6000564

  
**Customer Service**  
 Kundenservice  
 Service Consommateurs  
 Servicio Al Consumidor  
[LEGO.com/service](http://LEGO.com/service) or dial  

 : 00800 5346 5555  
 : 1-800-422-5346







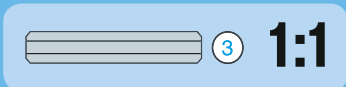
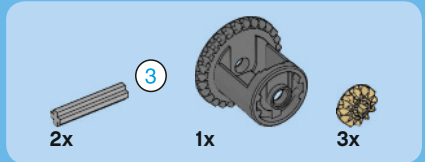
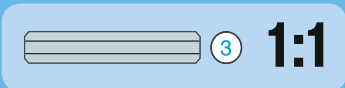
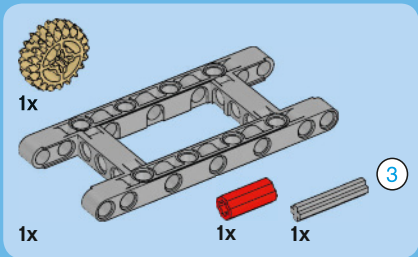
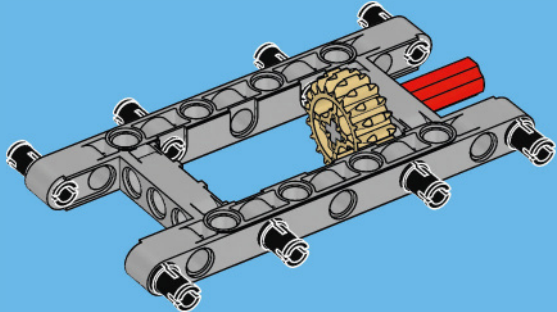
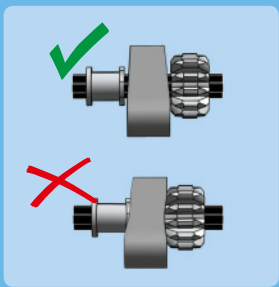
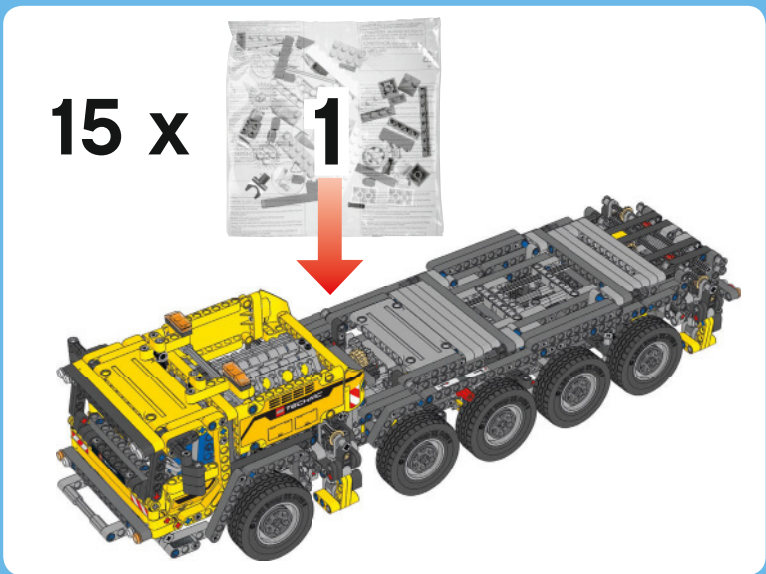

**1**

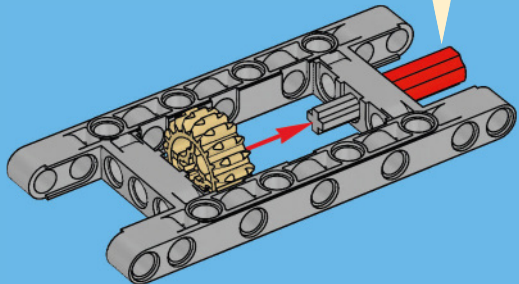
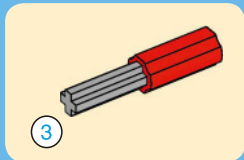

**3**

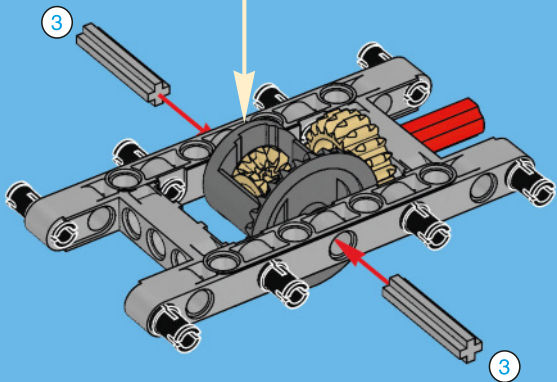
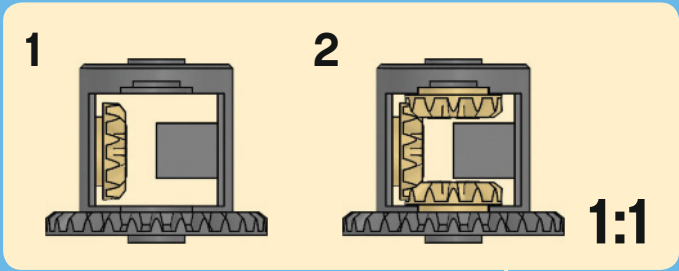



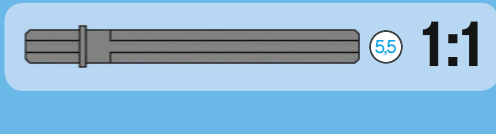
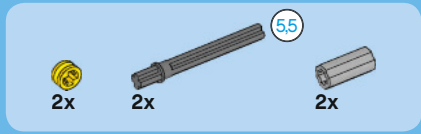

4

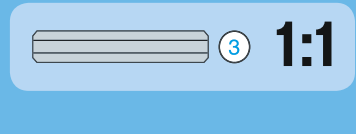
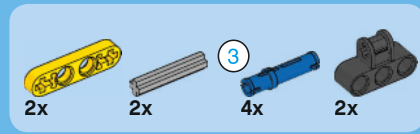
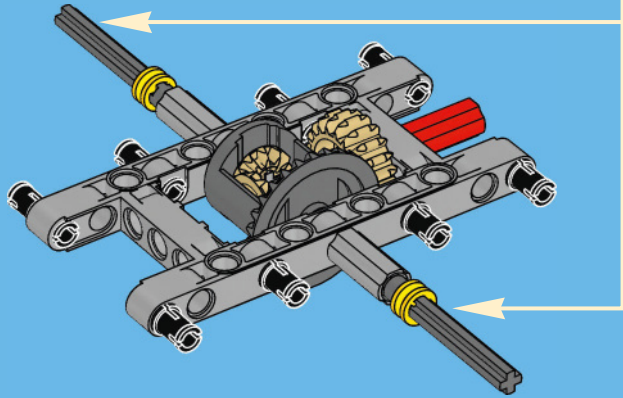
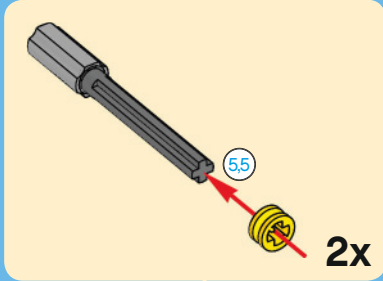

5

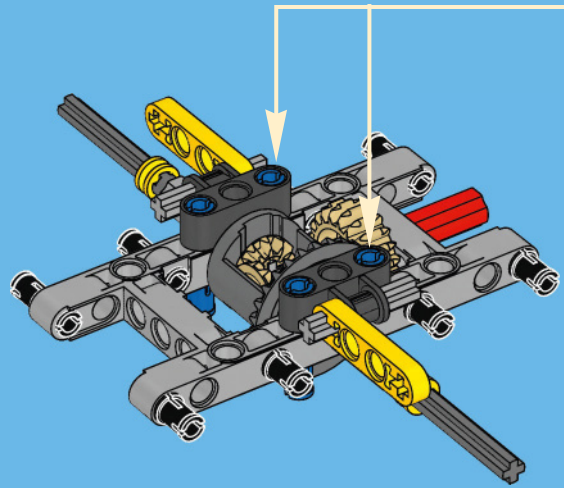
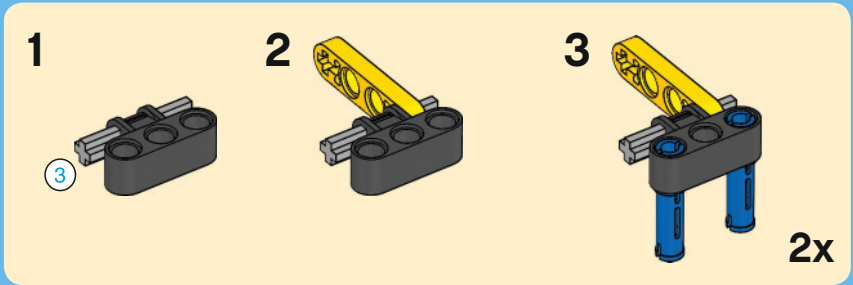





2x

# 6

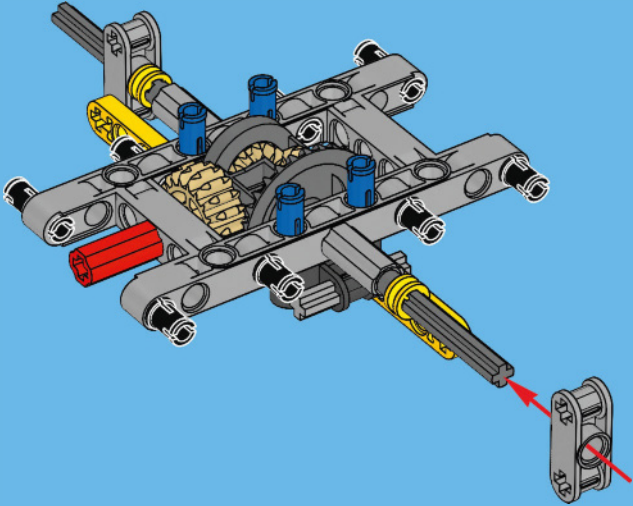

2x

# 7

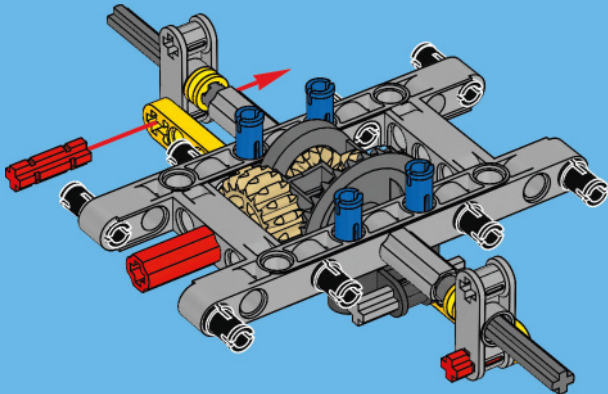

2x

# 8

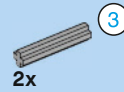
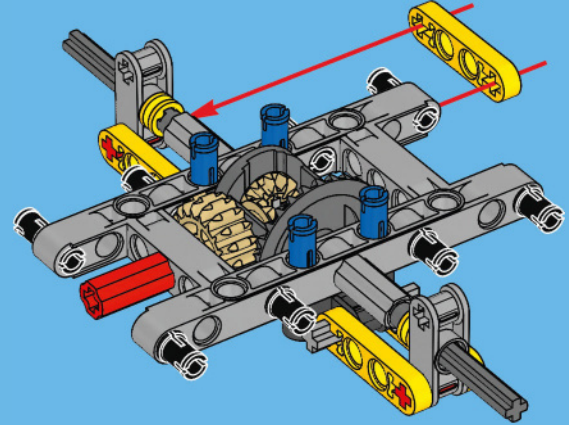

2x



2x



2x

# 9

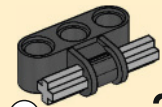

2x

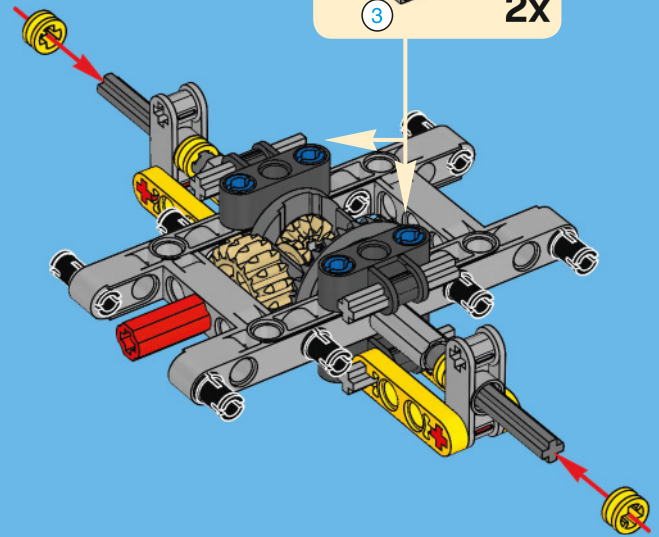



# 10

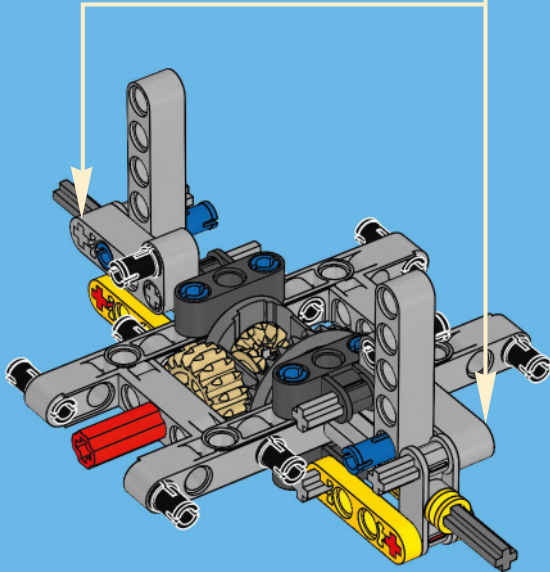
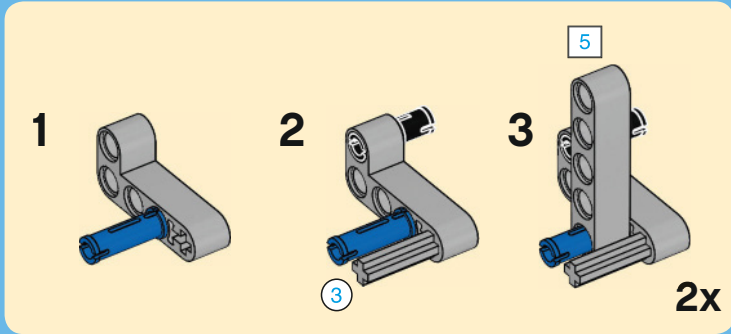
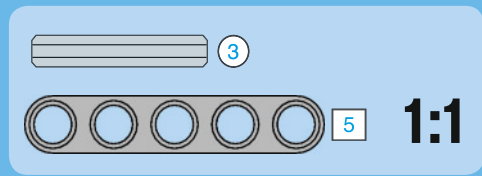
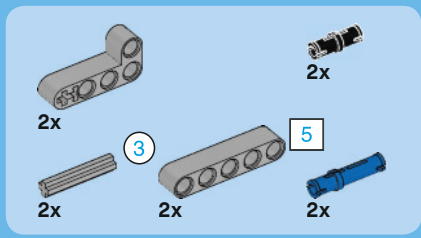

# 11

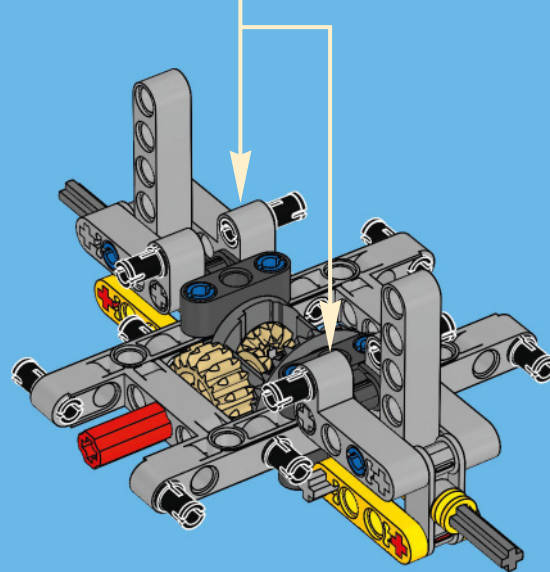
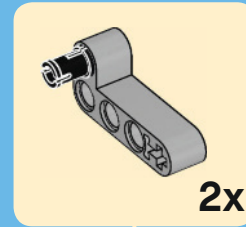
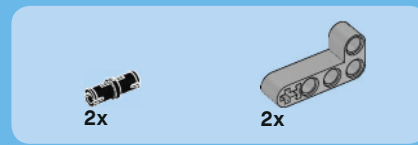



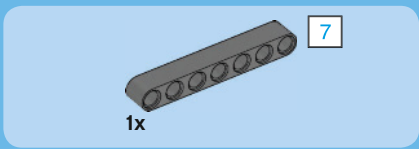
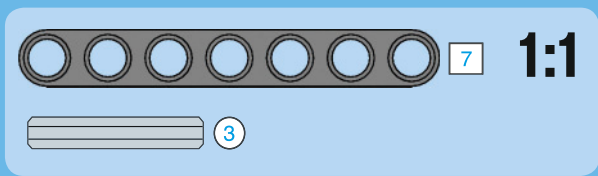
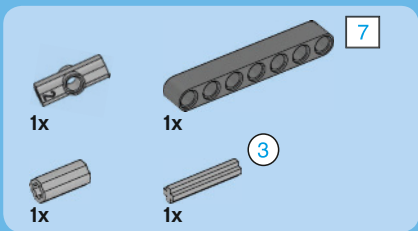

# 12

# 13

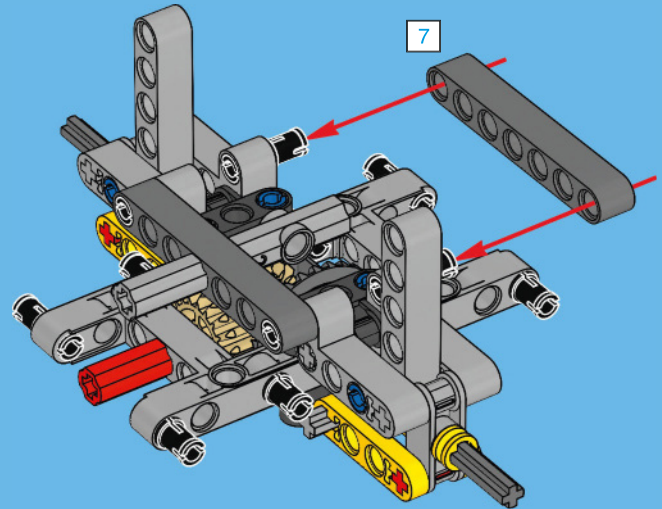
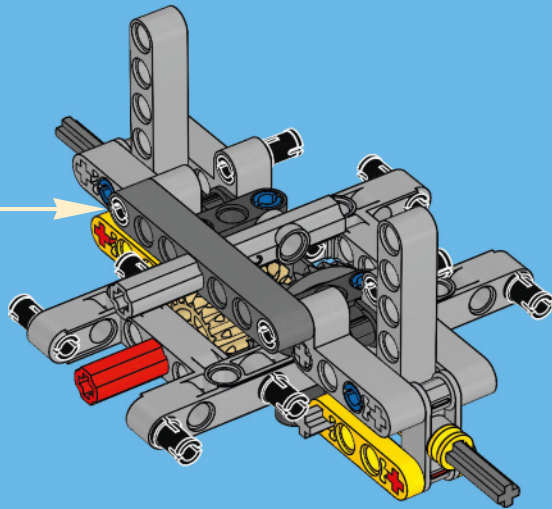
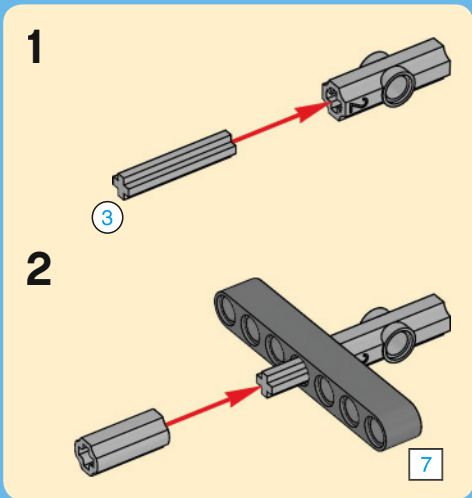

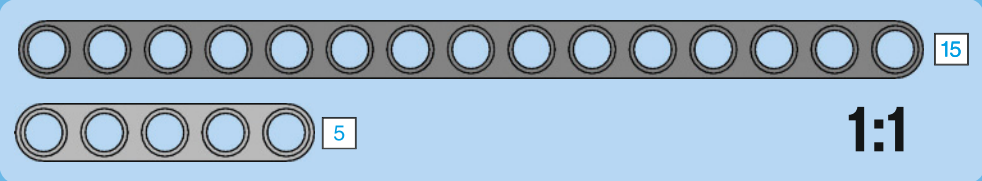
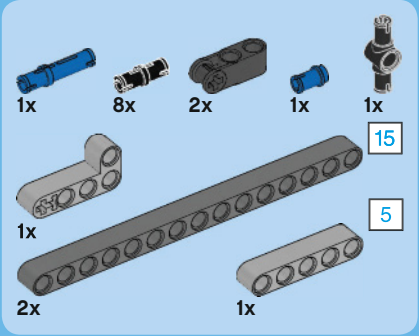

# 14

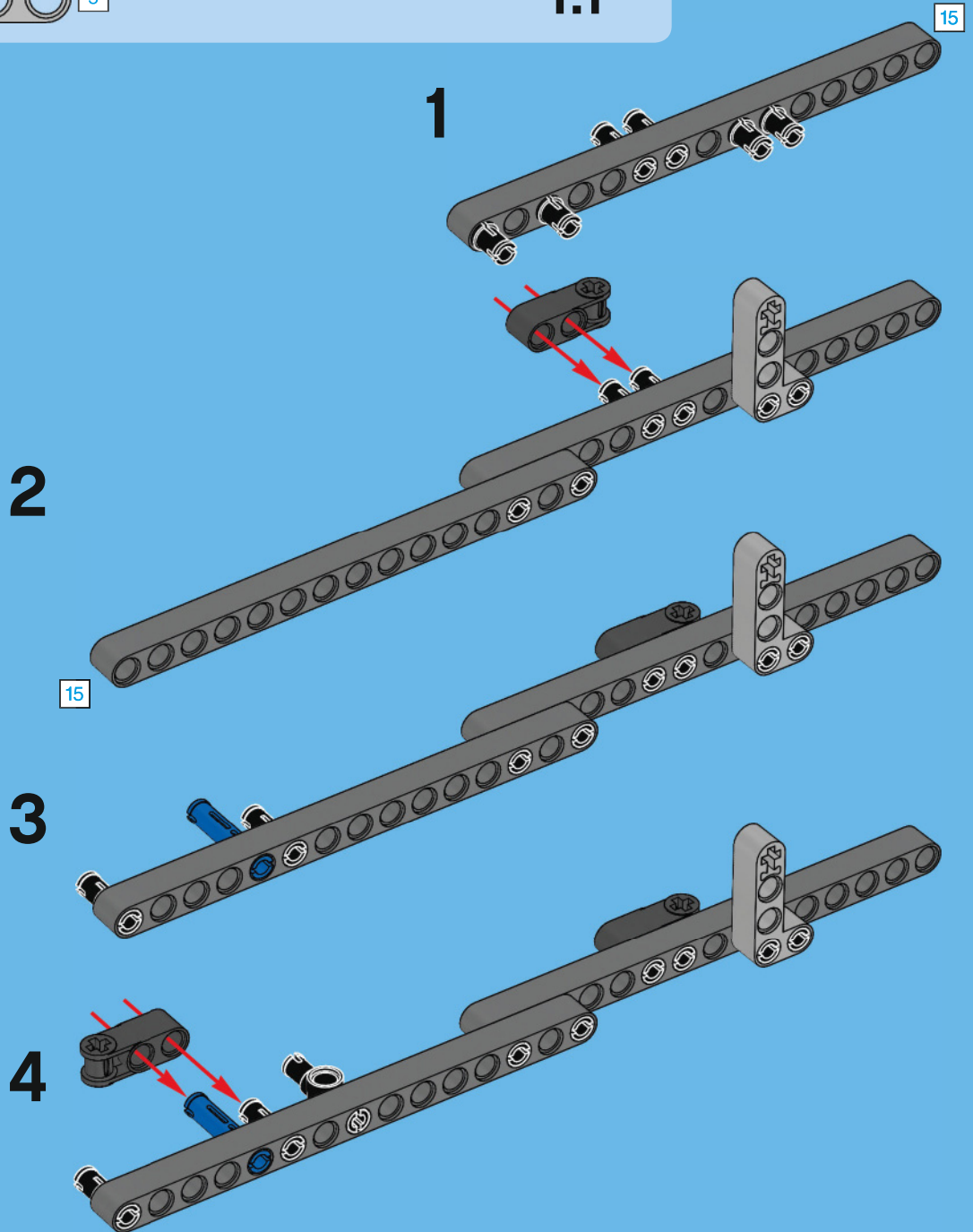



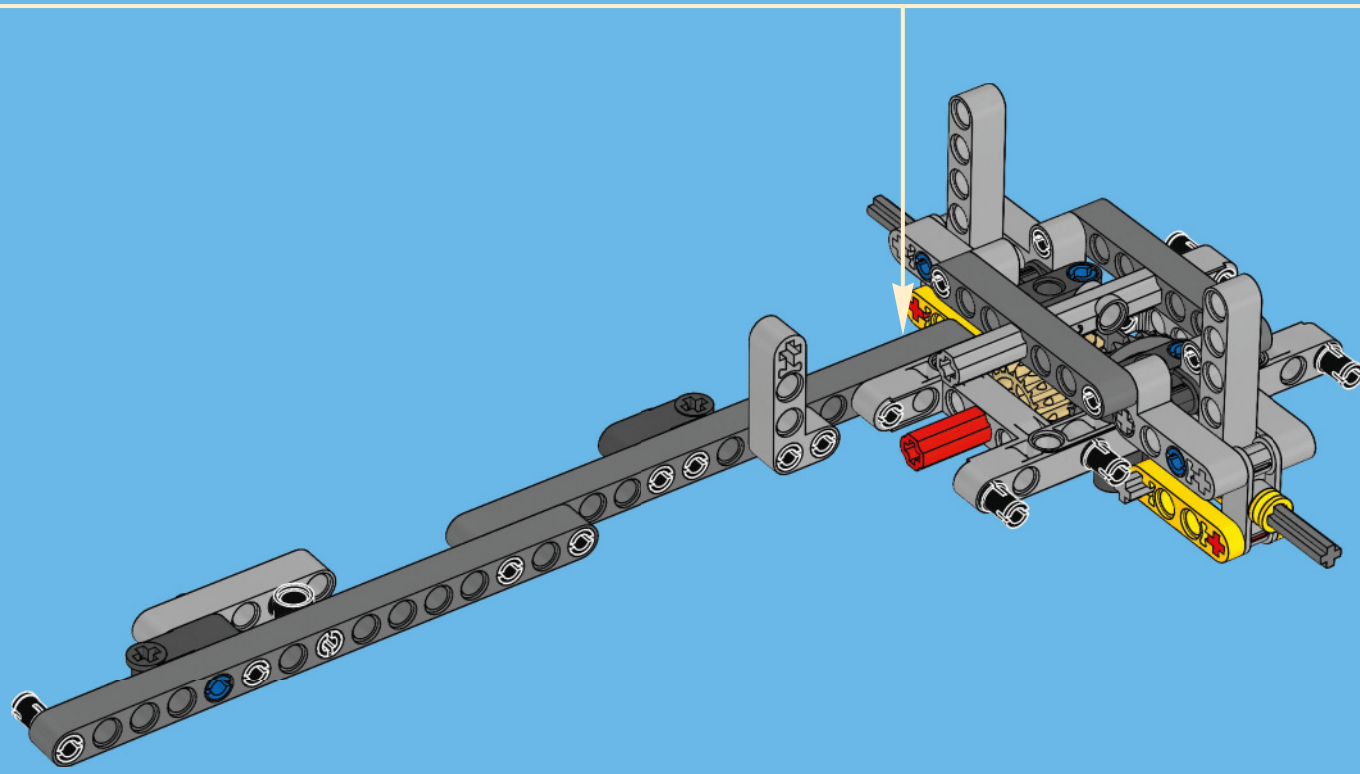
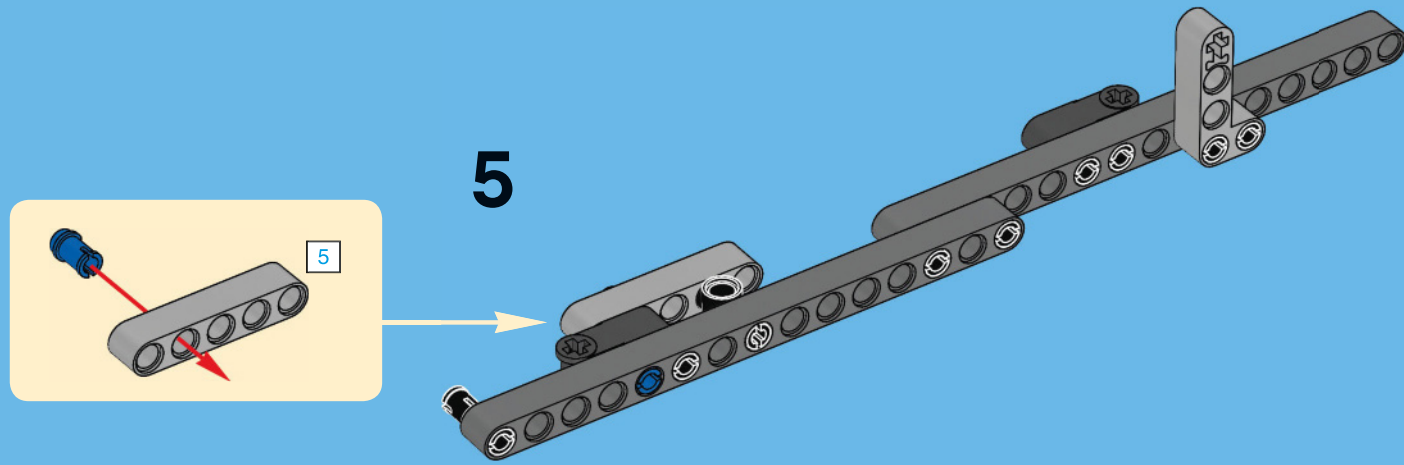

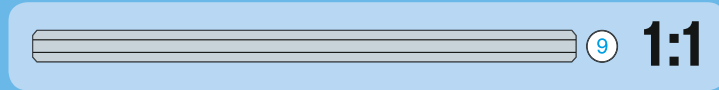
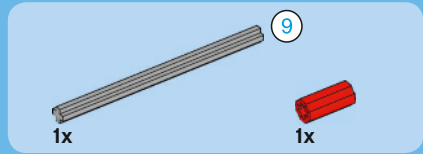

15

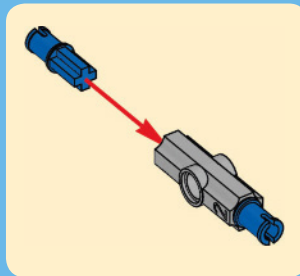
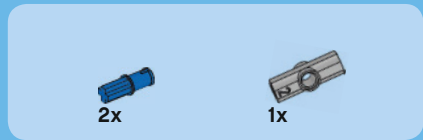
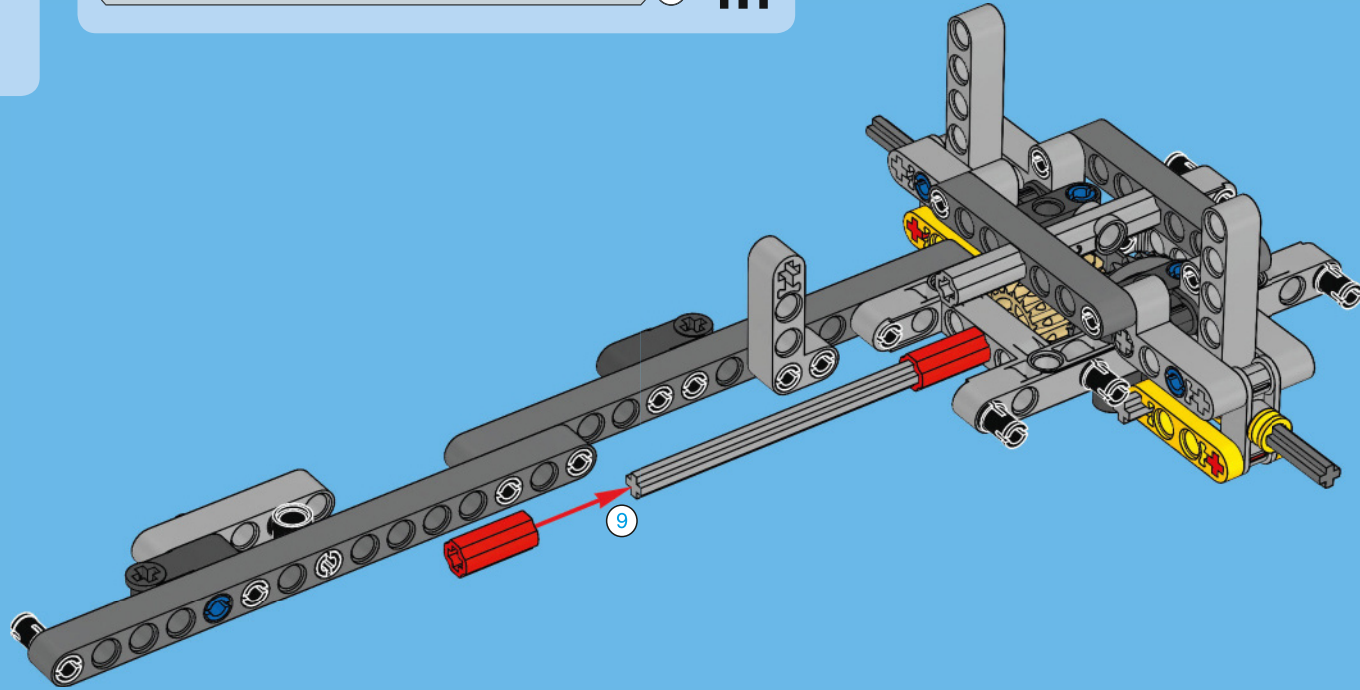

16

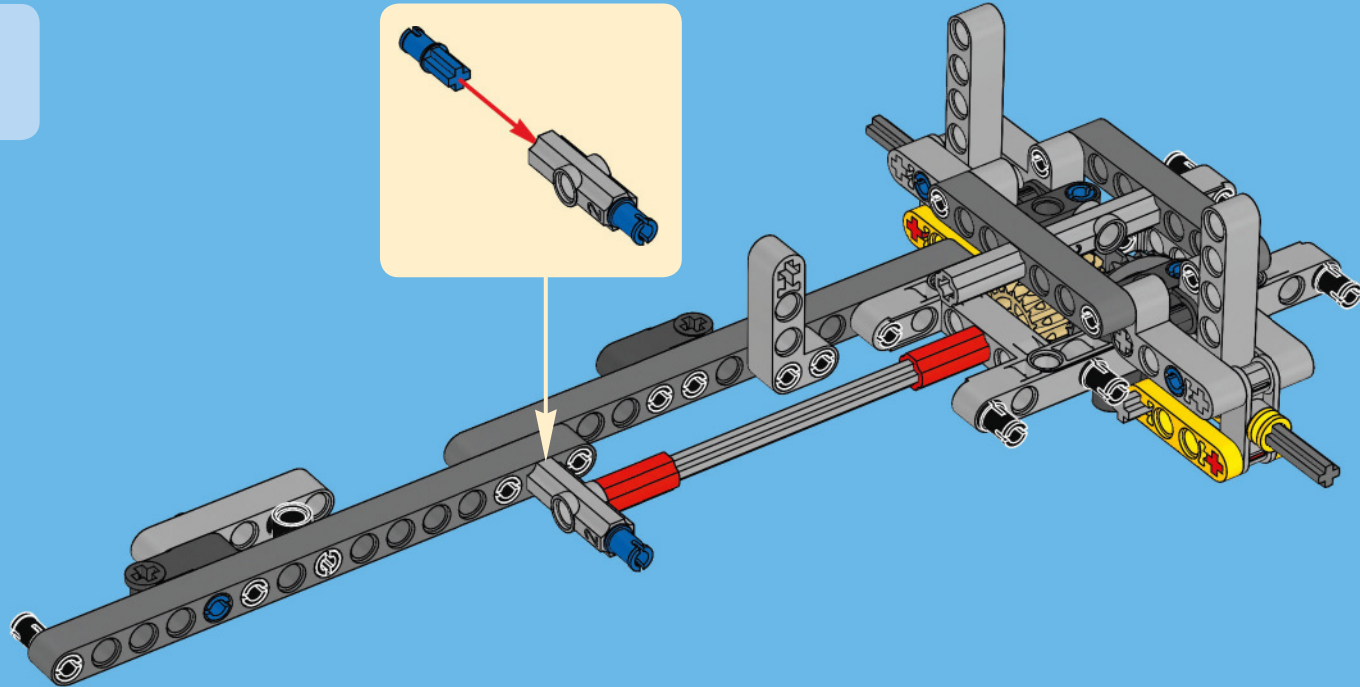



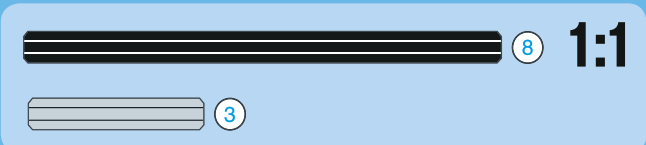
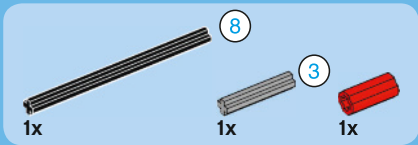

17

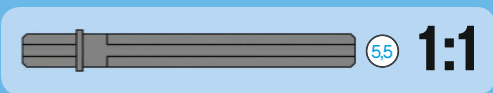
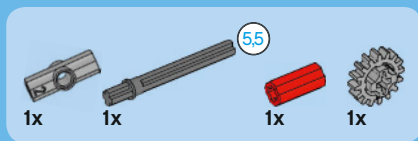
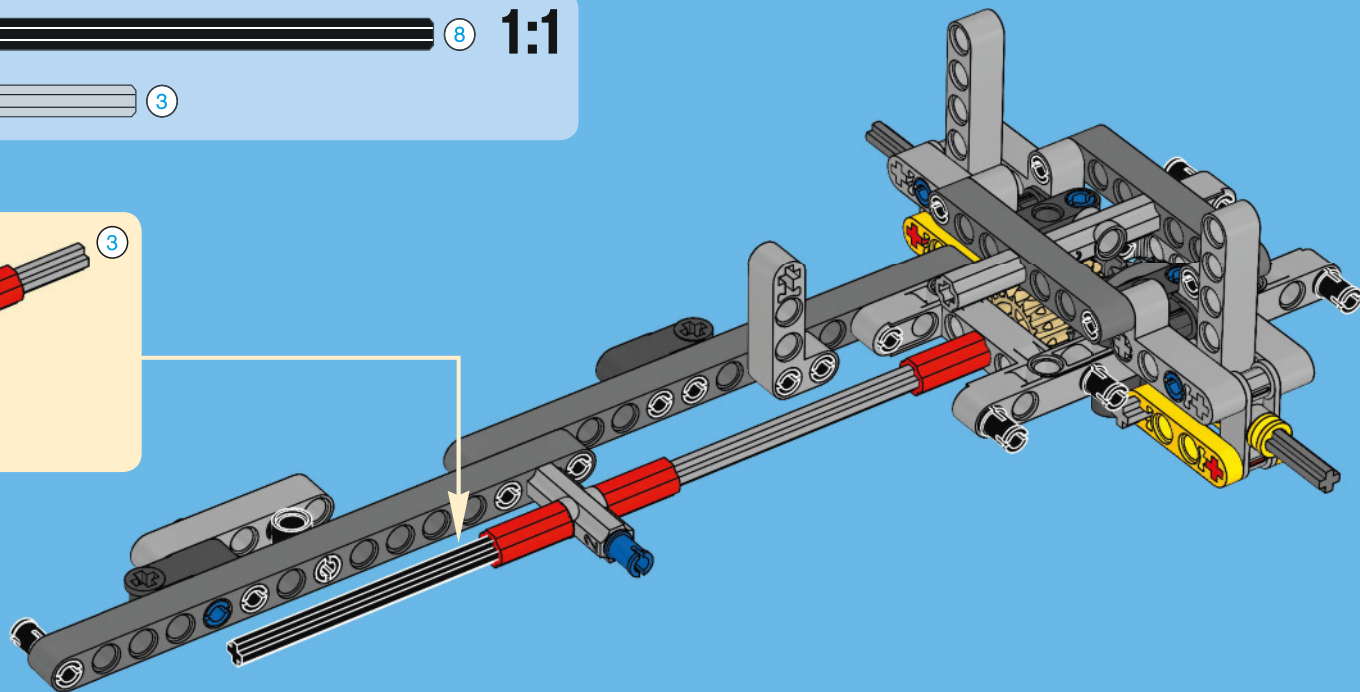
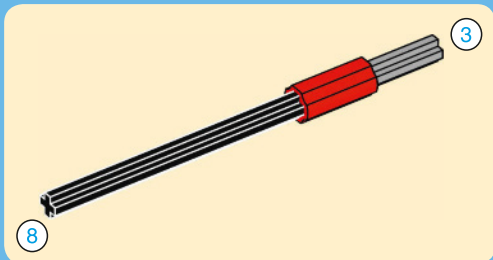

18

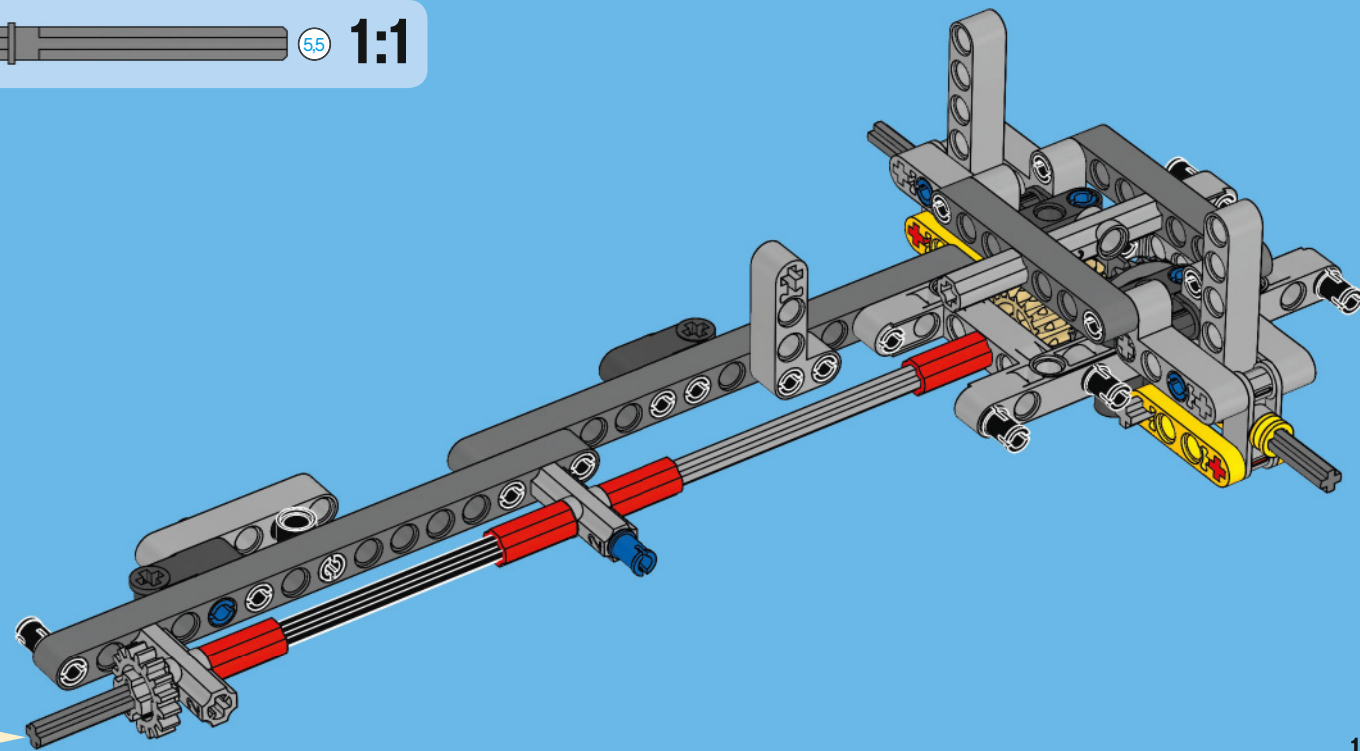
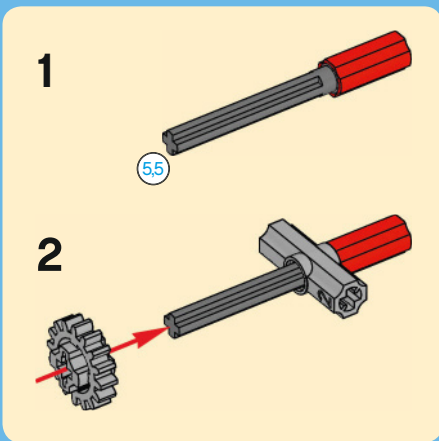

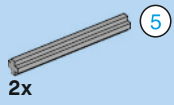

19

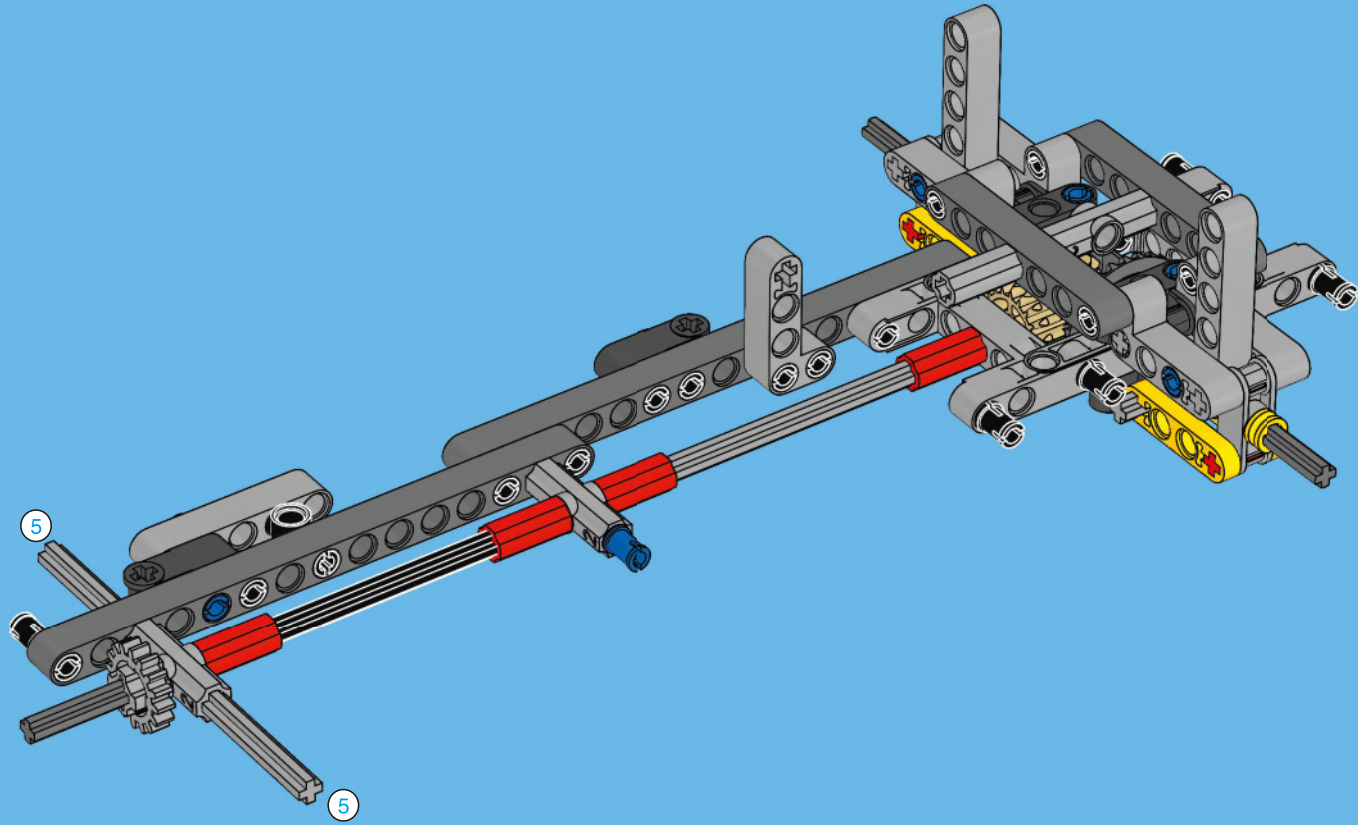



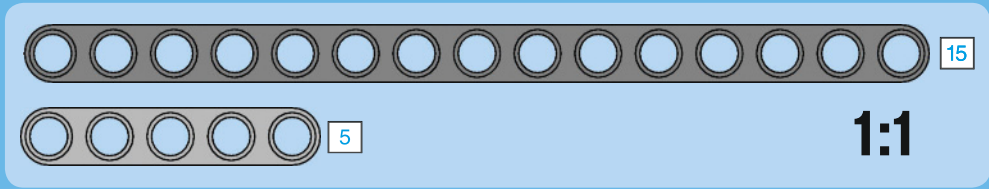
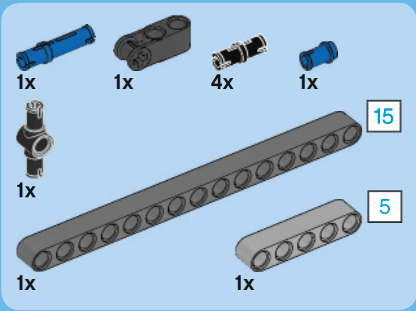

20

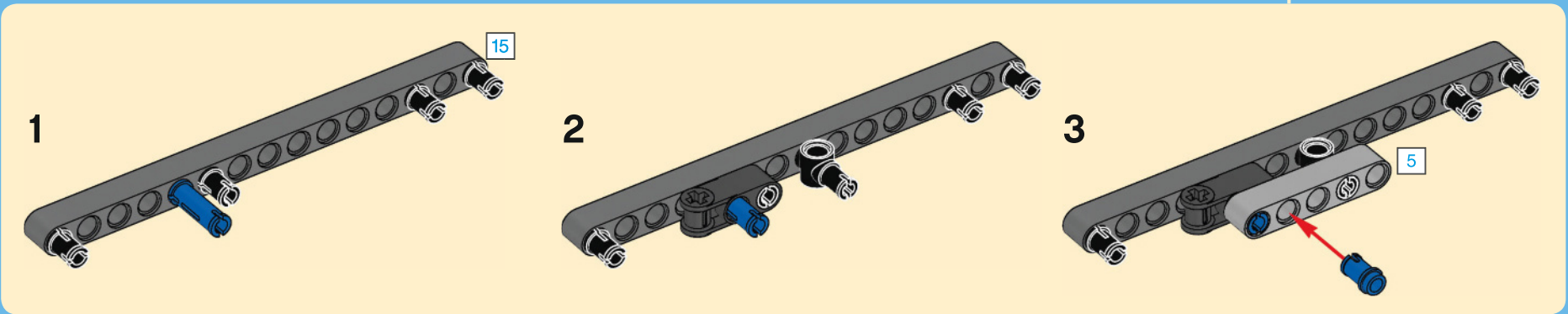
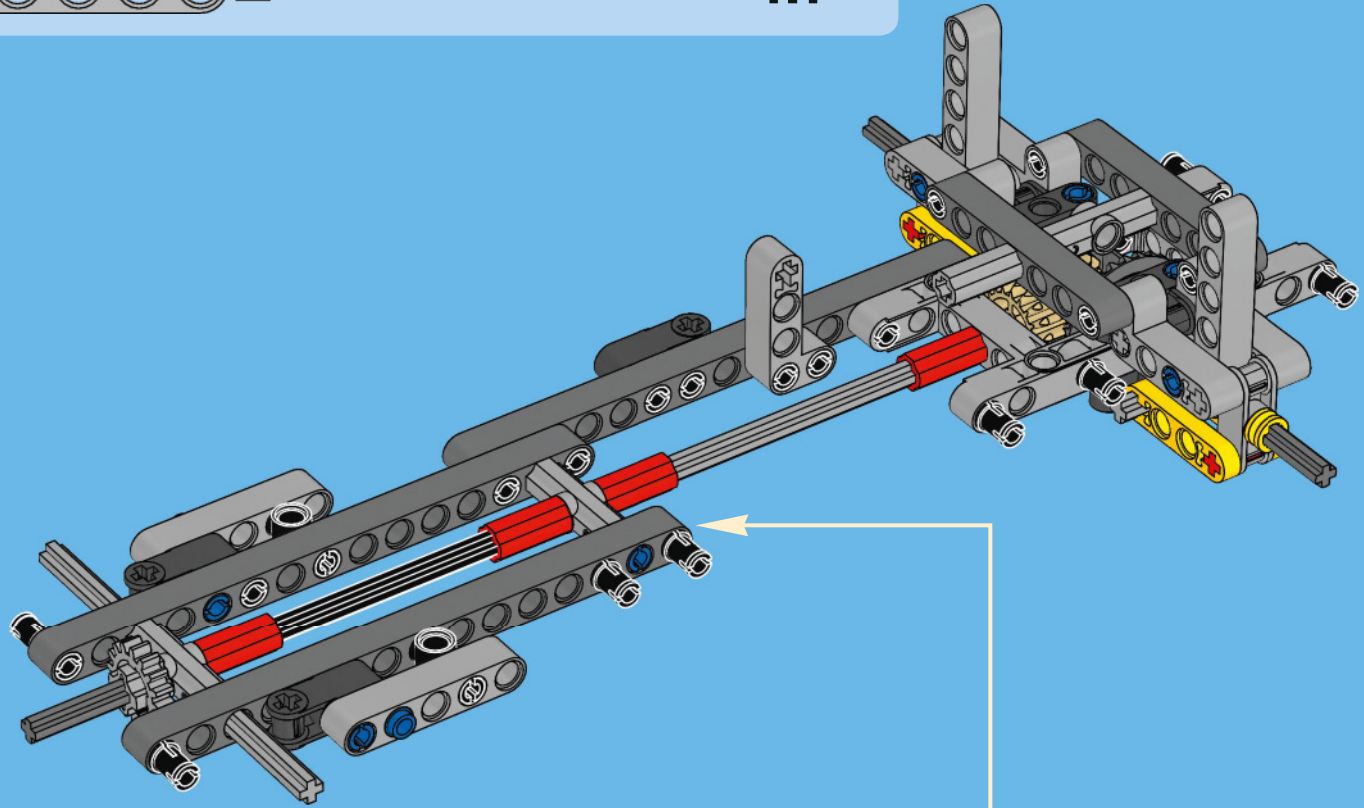

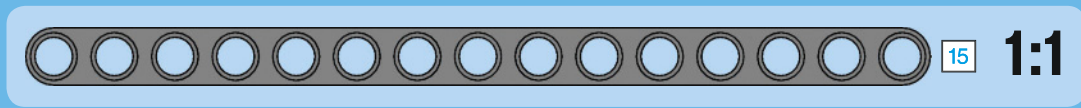
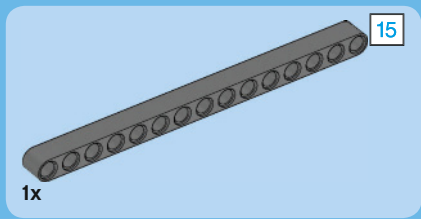

21

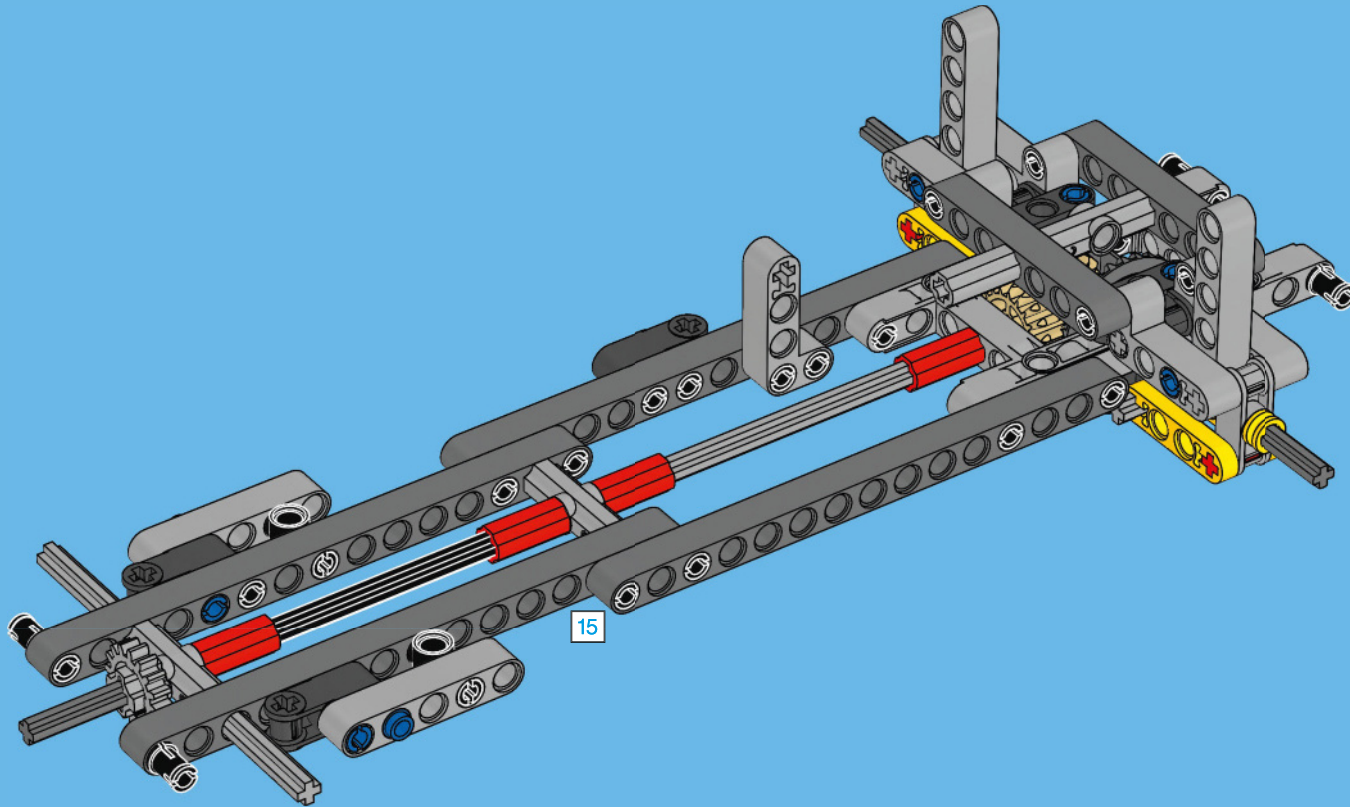



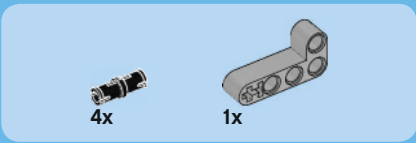

22

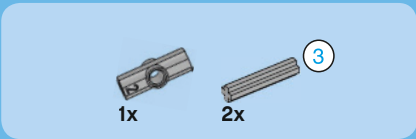
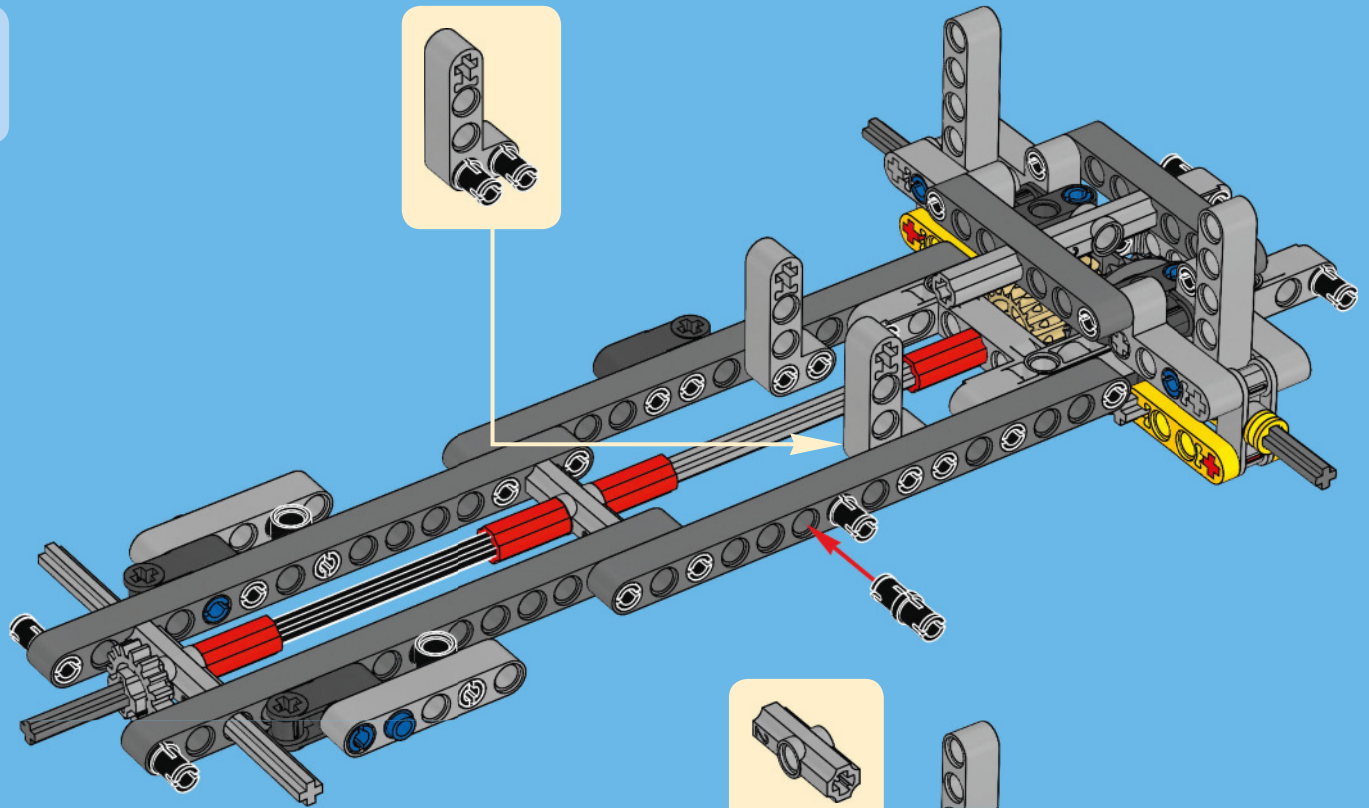

23

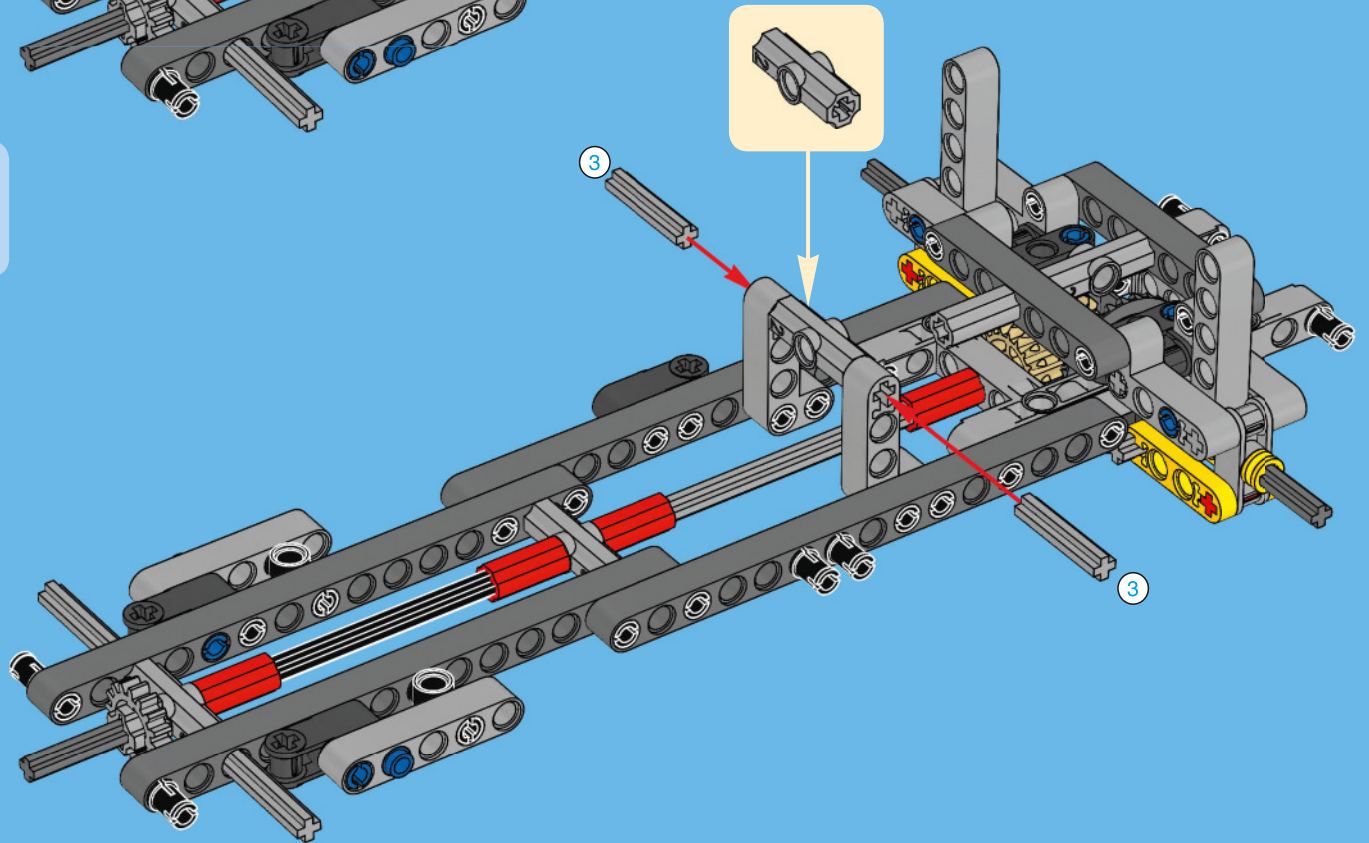

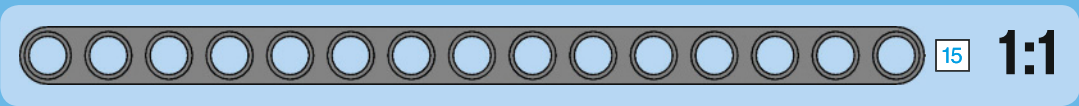
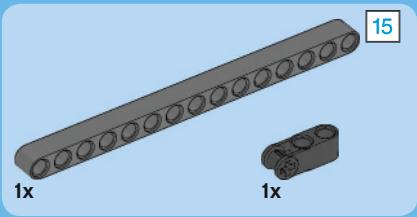

24

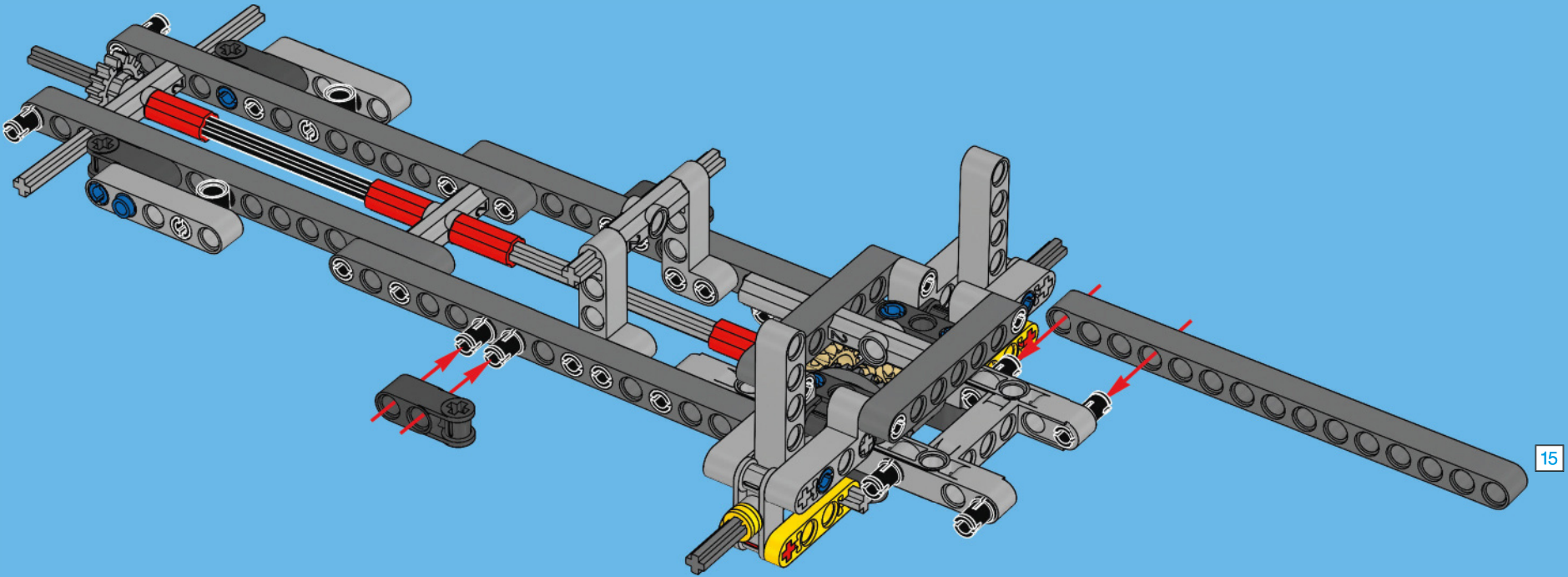



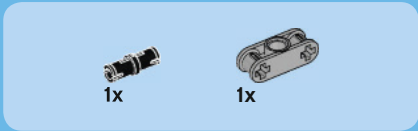
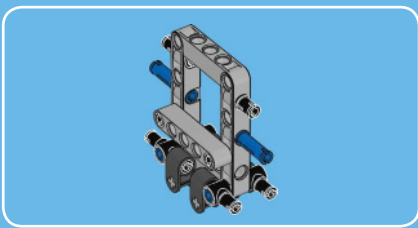

1

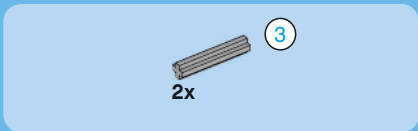
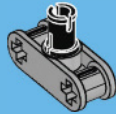

2

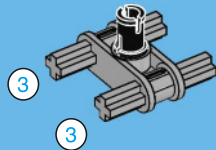

3

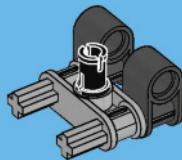

4

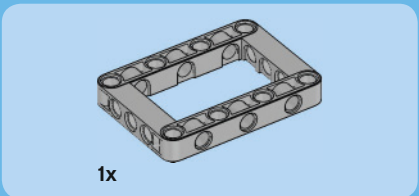
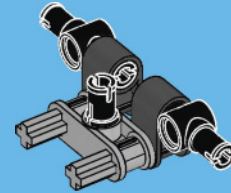

5

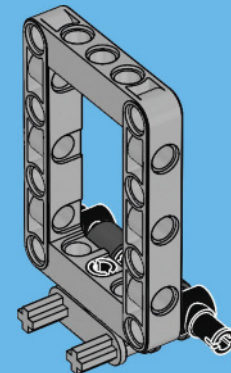



2x

6

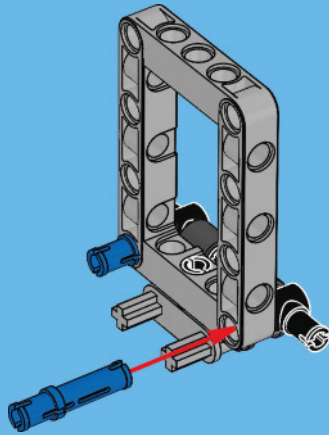

2x



2x

7

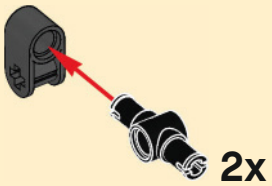

2x

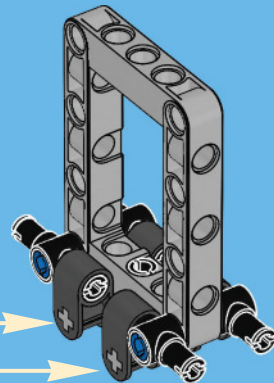

2x

8

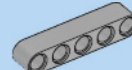
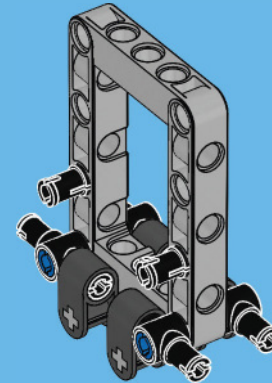

1x

5

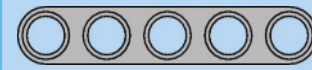

5

1:1

9

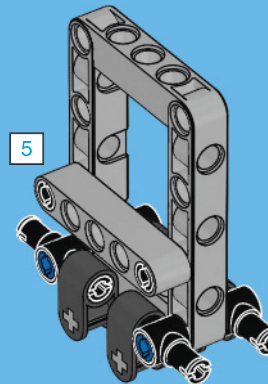



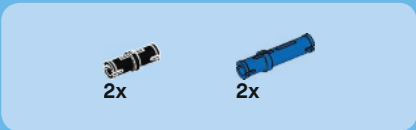

10

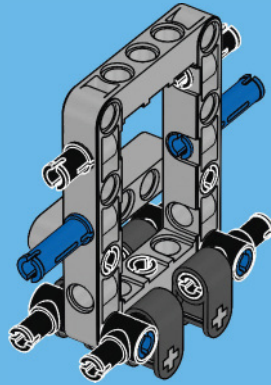

25

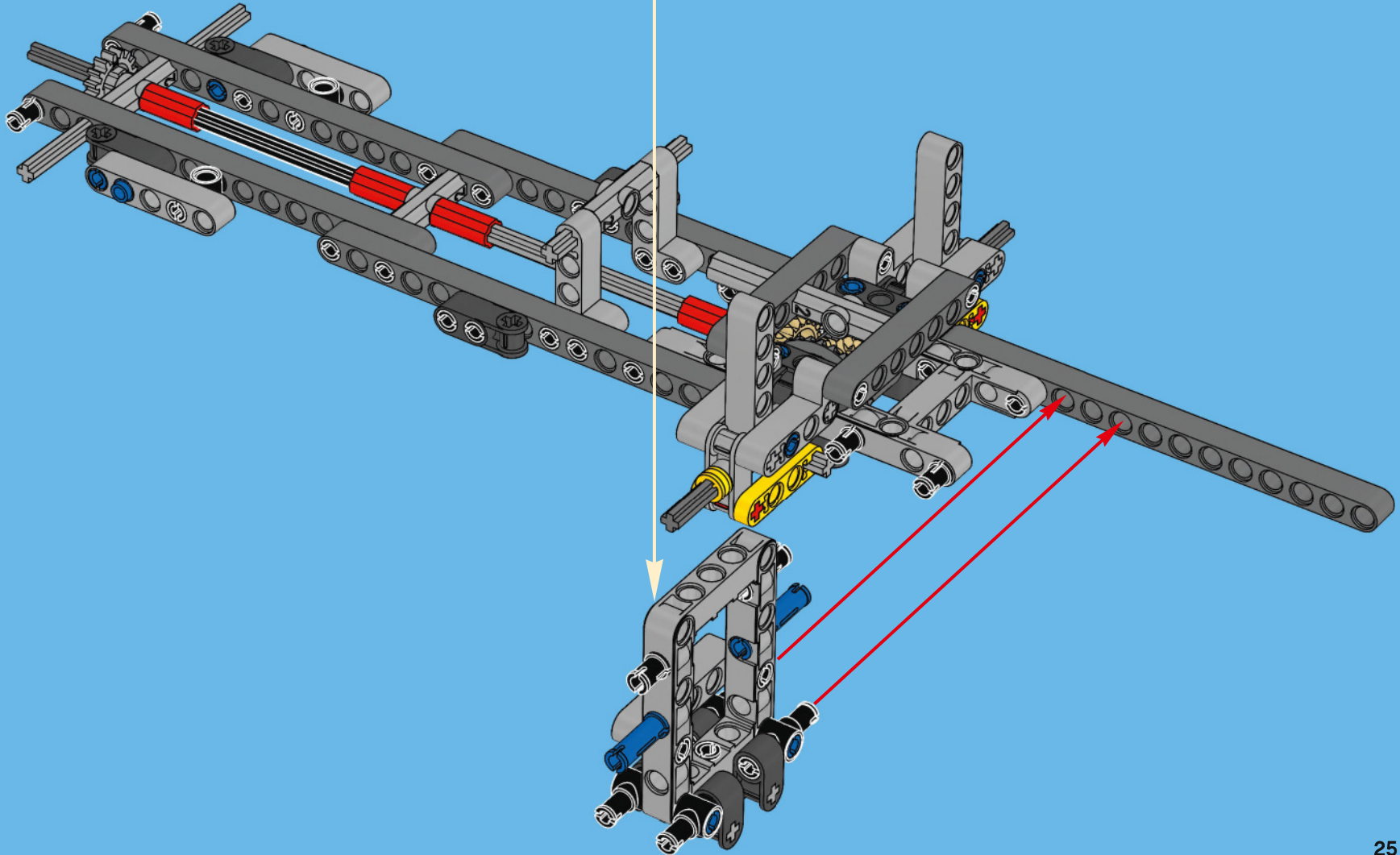

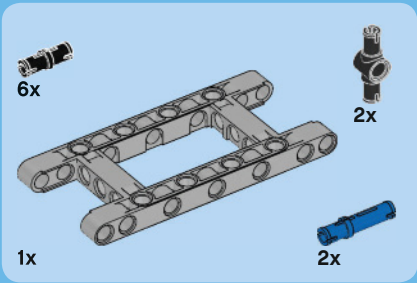

26

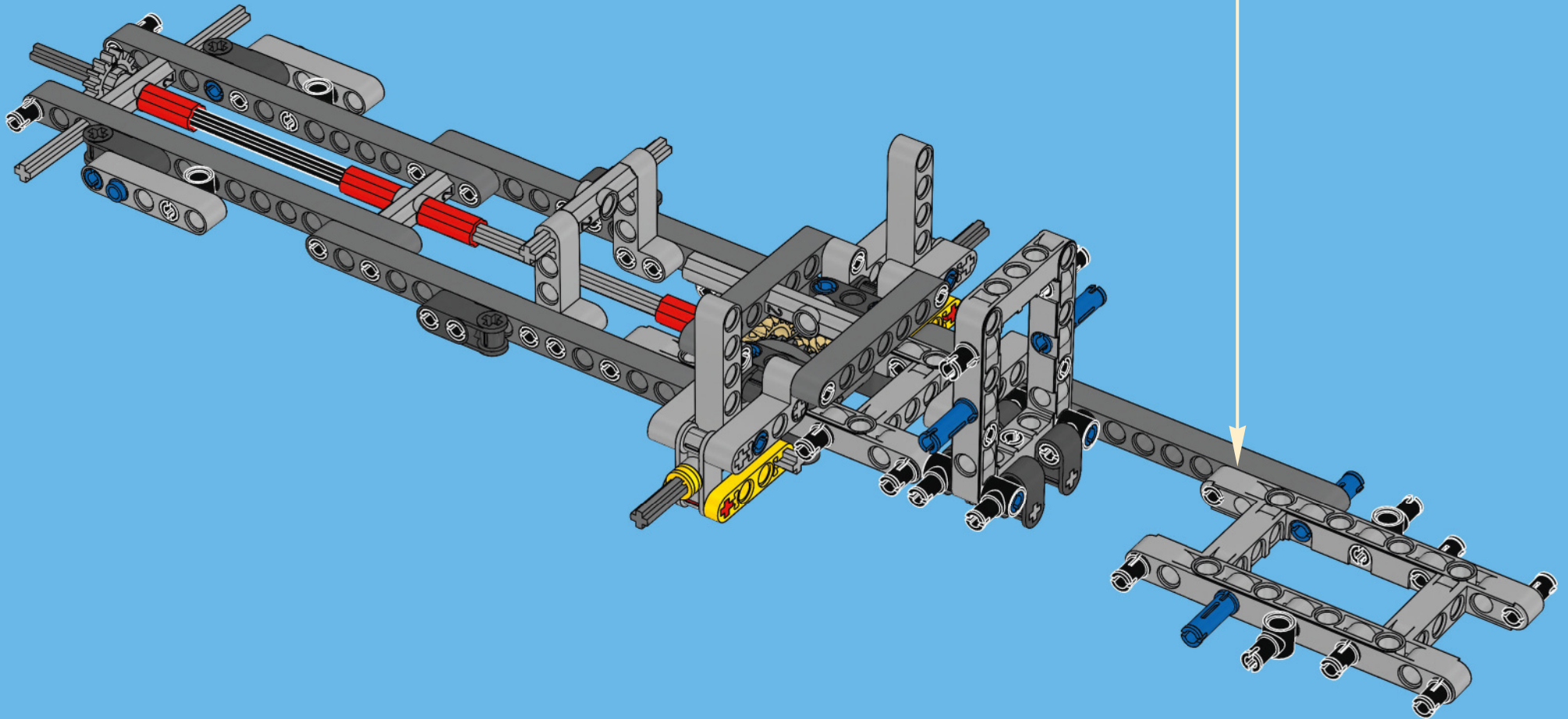
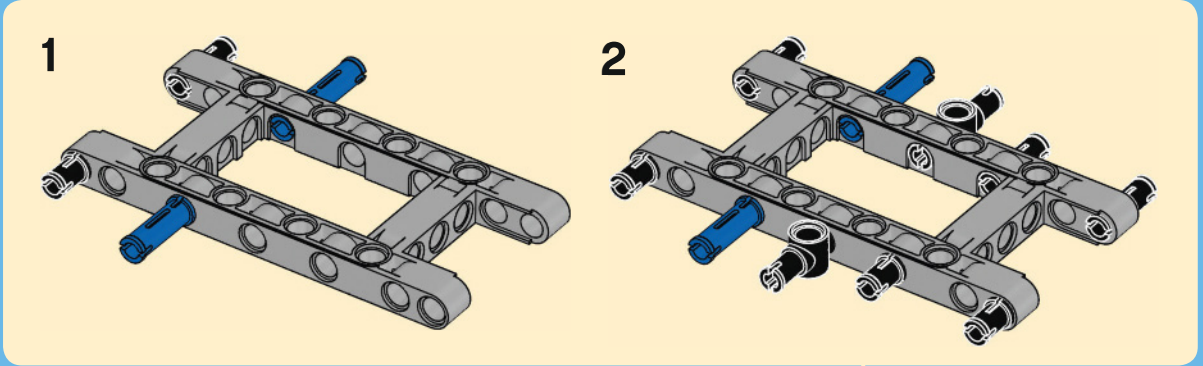



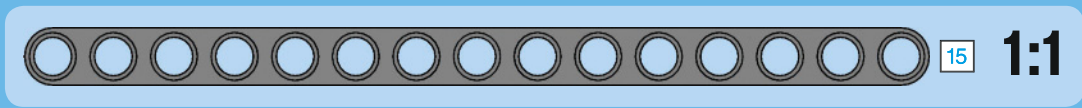
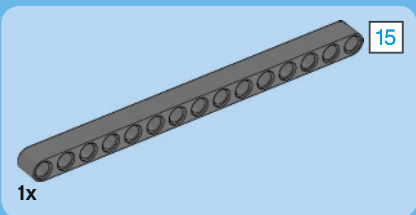

27

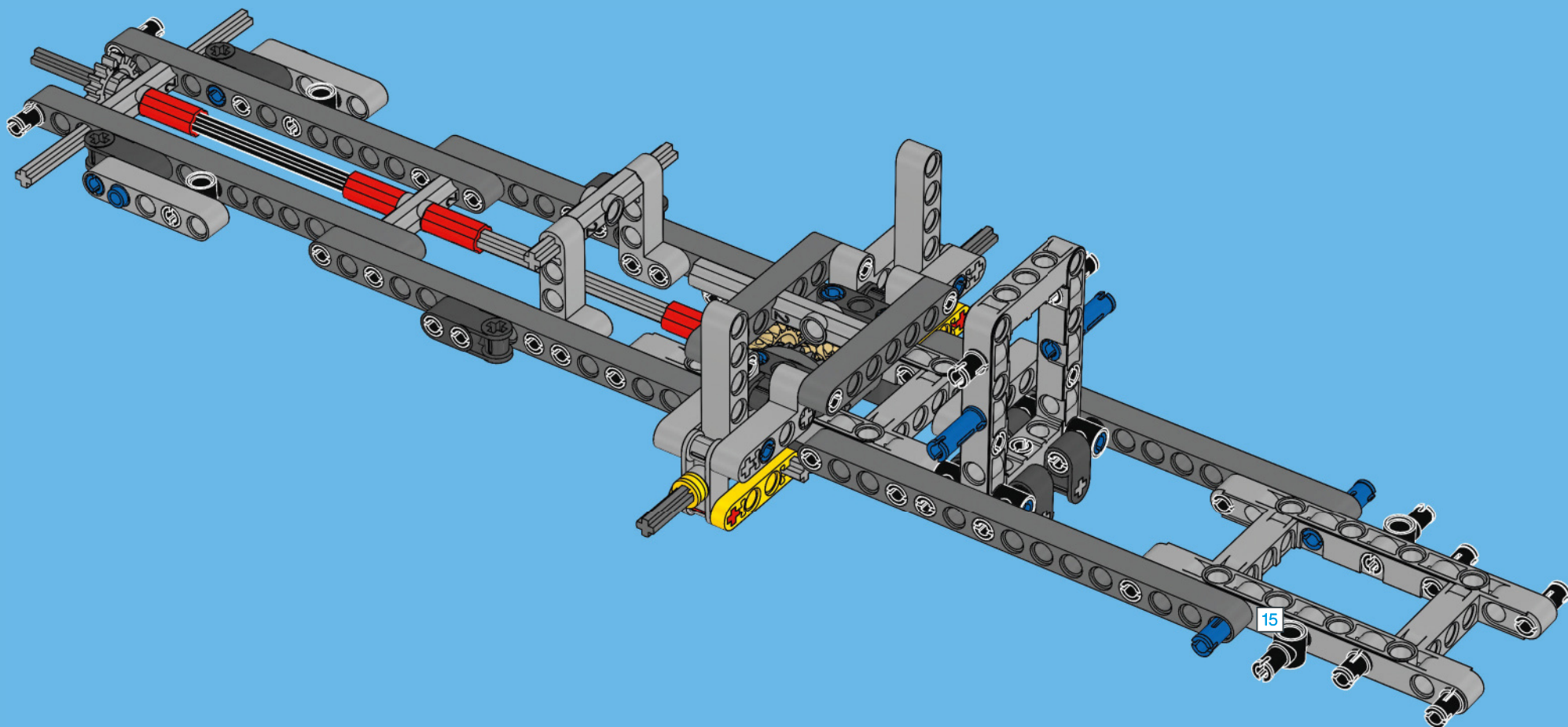



2x



2x



2x

# 28

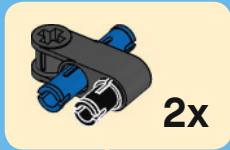
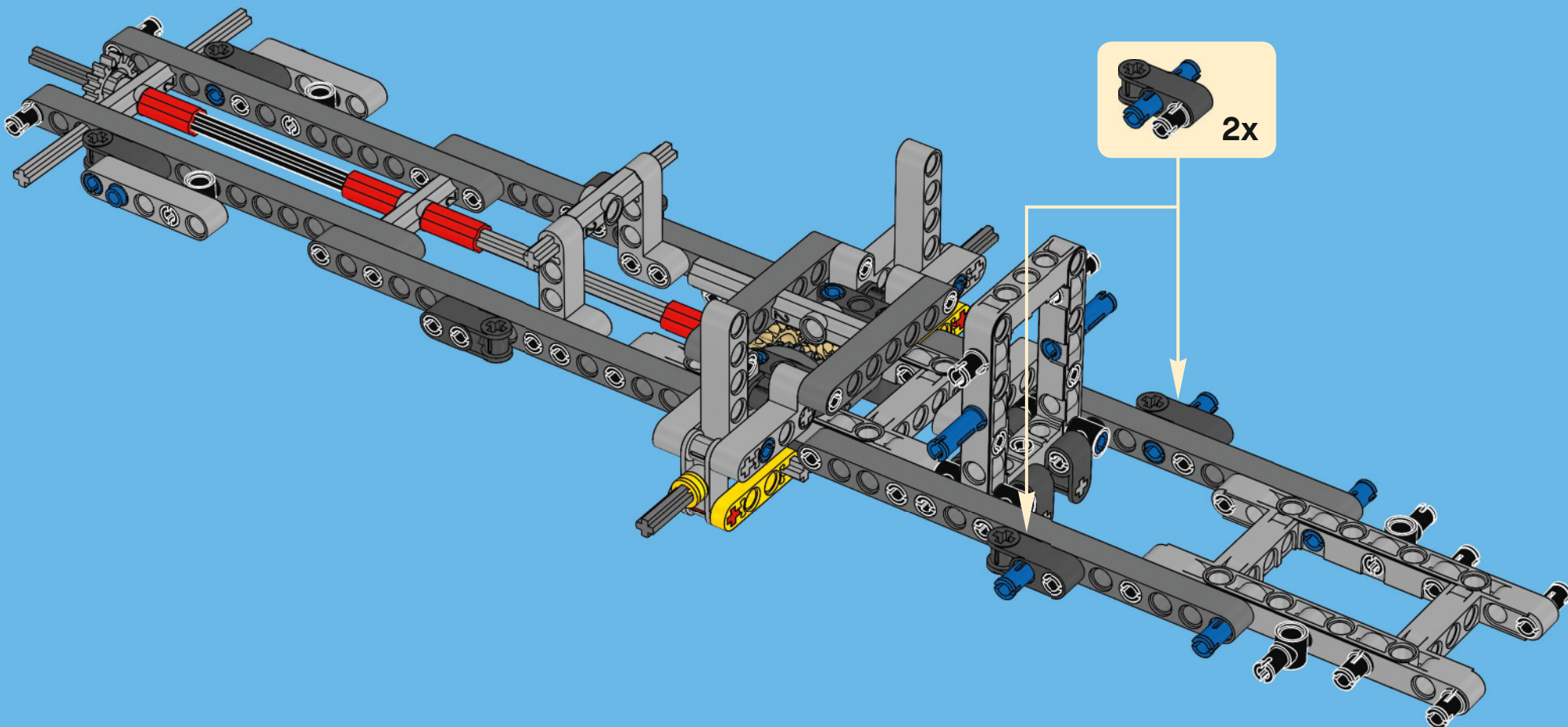

2x



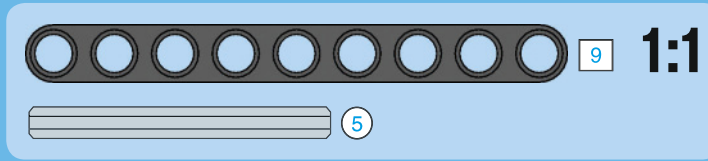
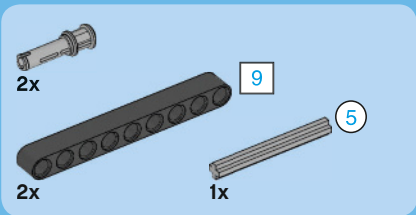

29

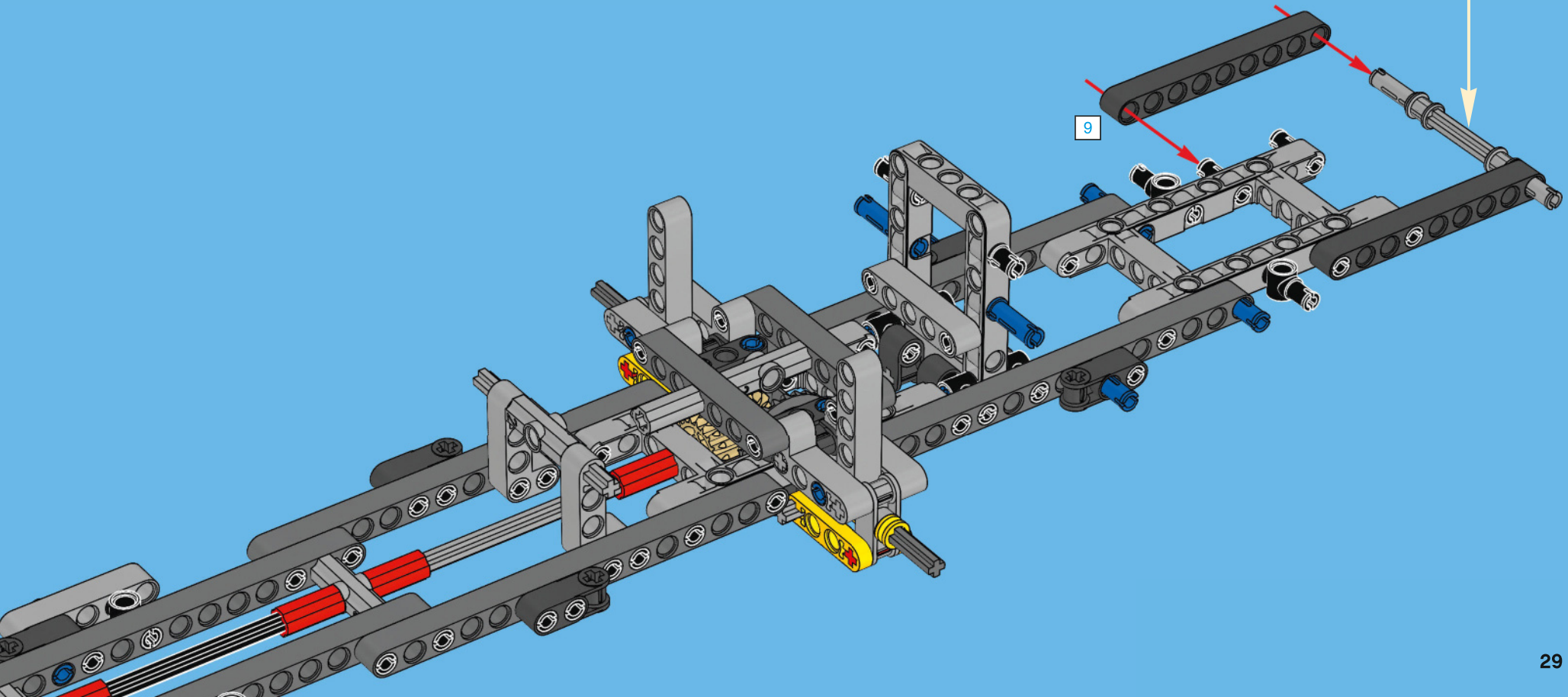
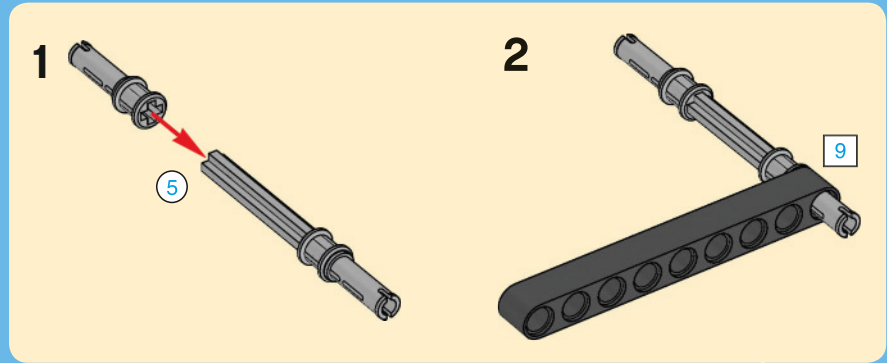

2x

2x

2x

# 30

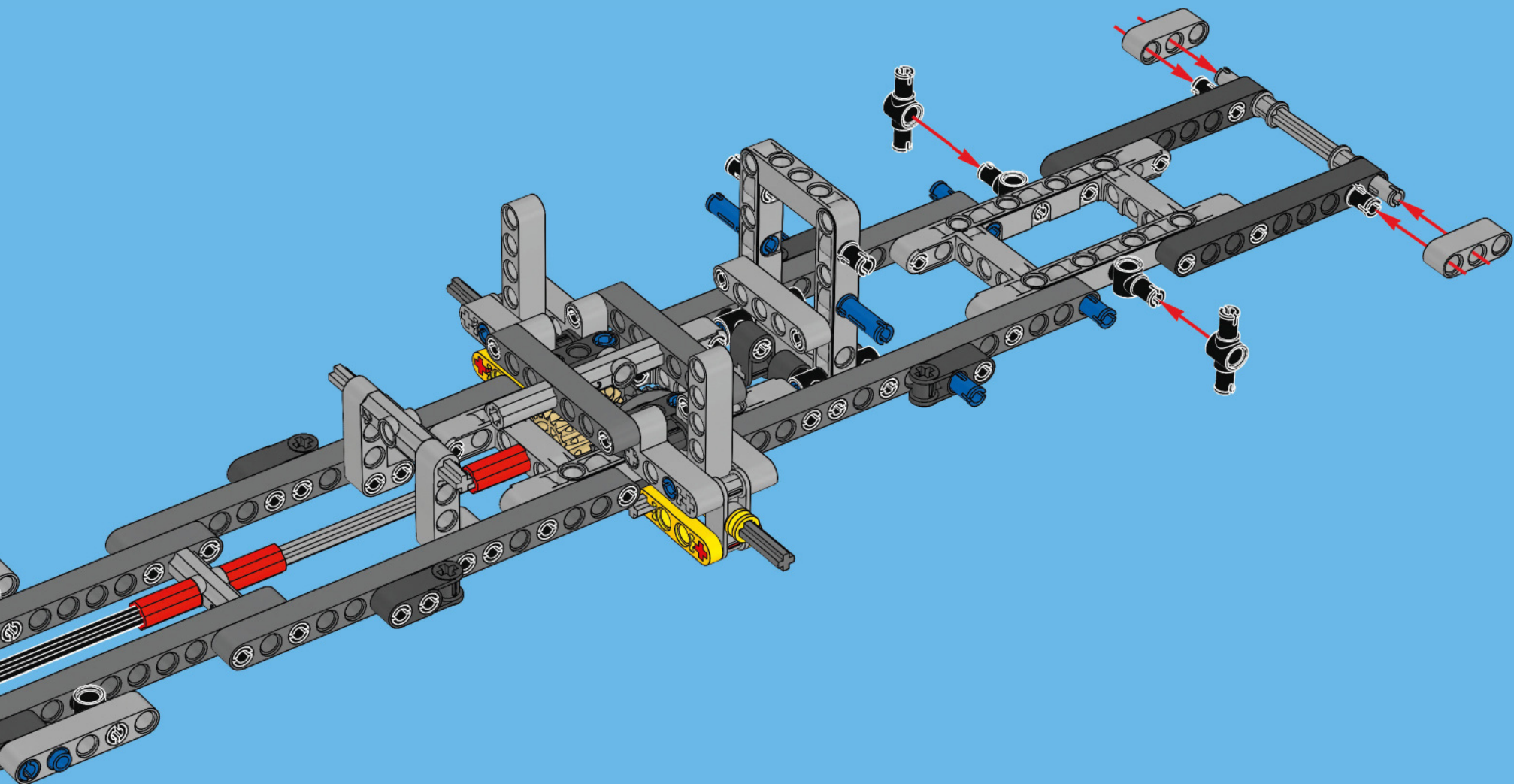



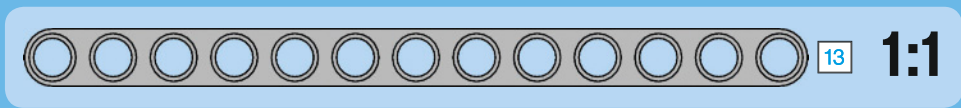
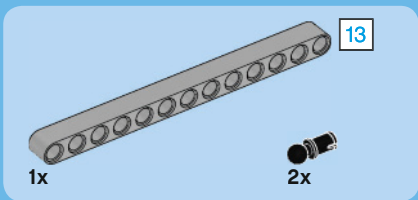

# 31

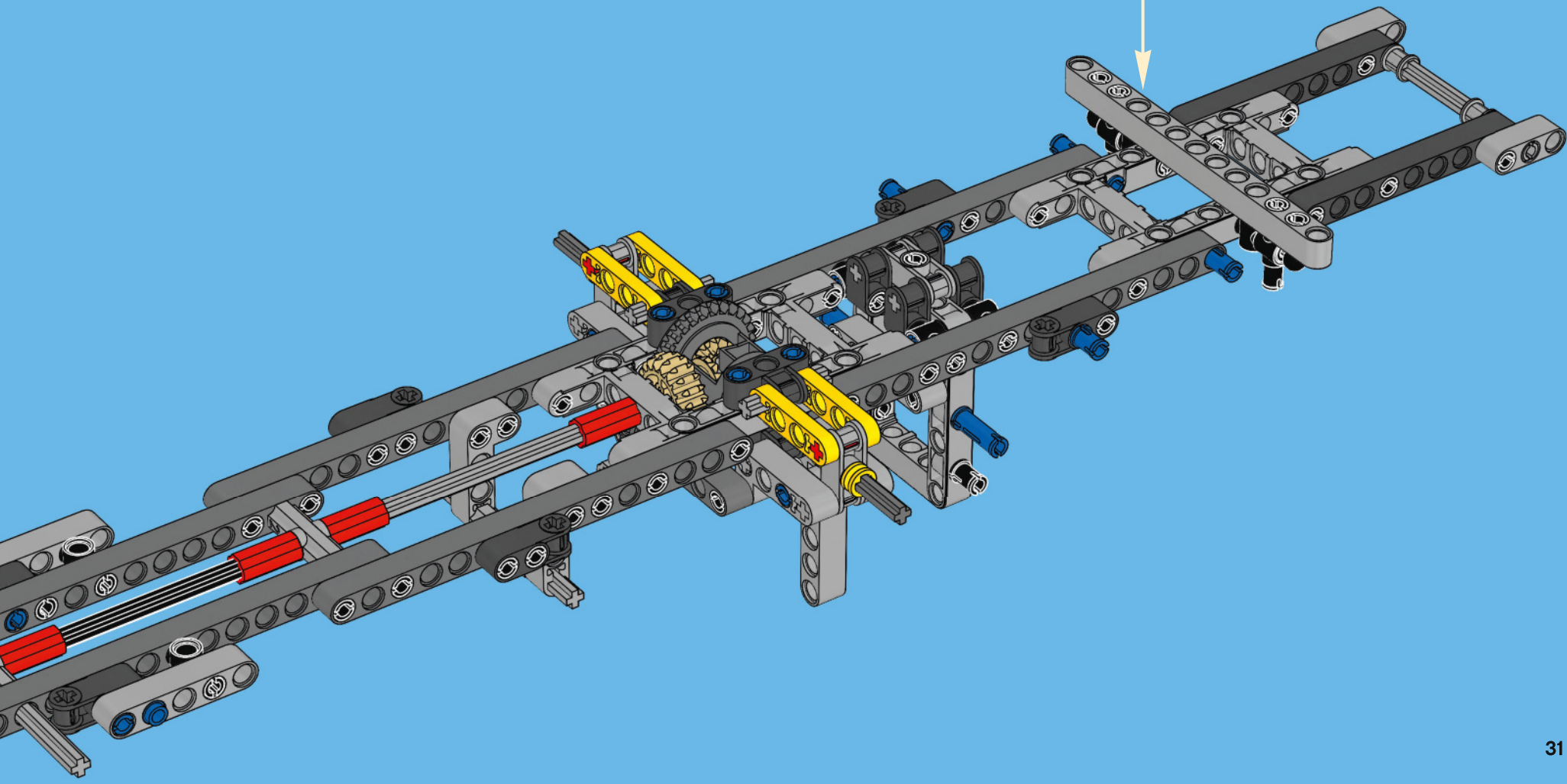
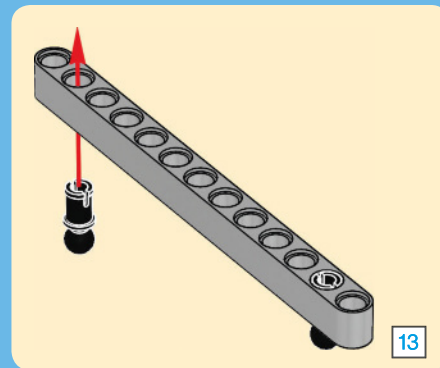

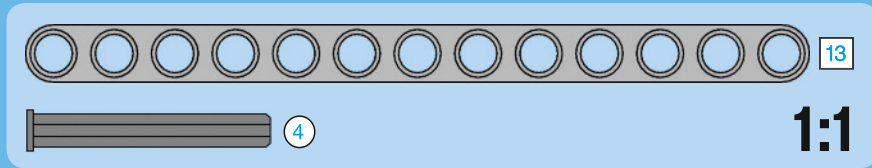
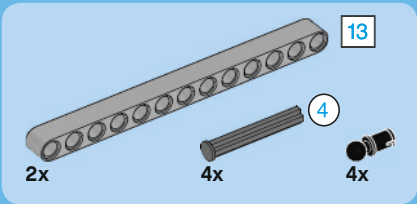

32

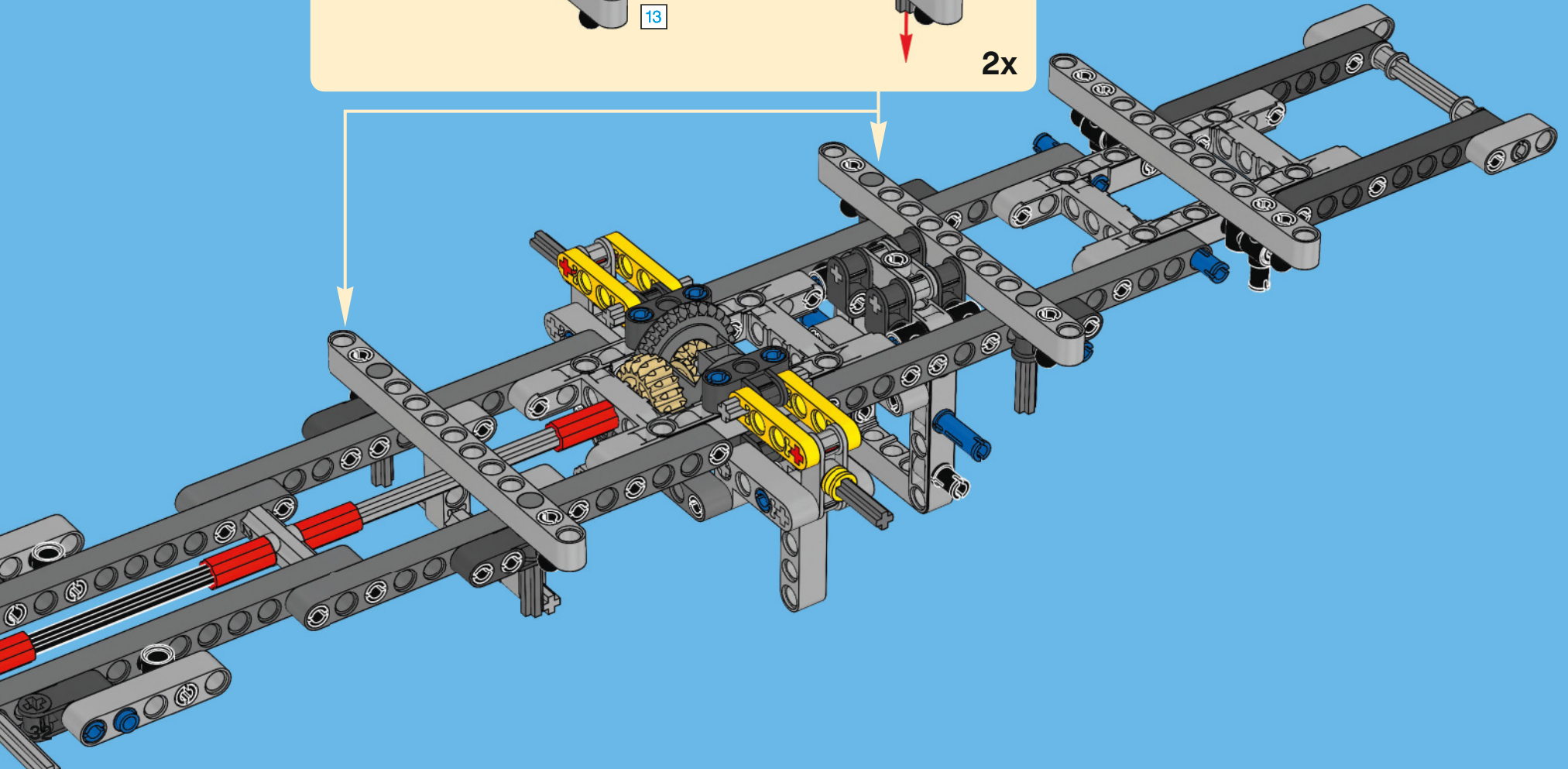
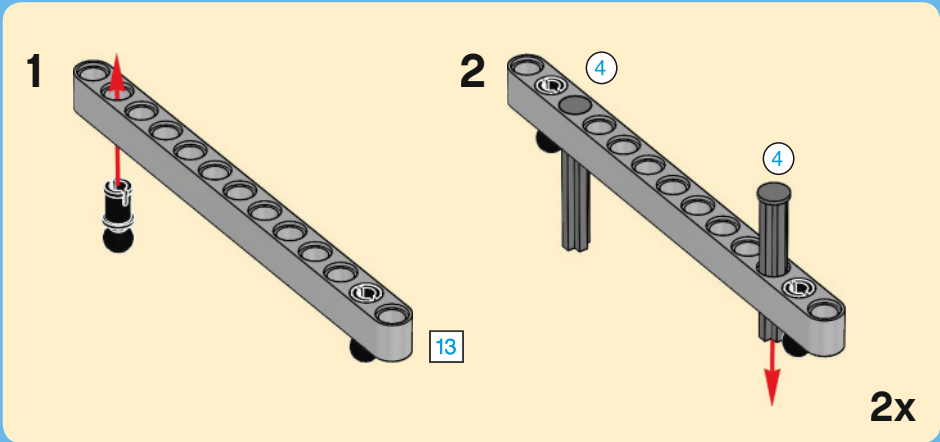

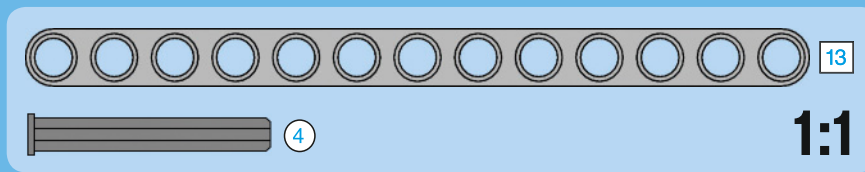
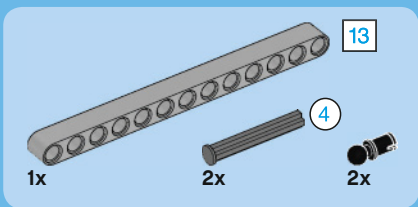

# 33

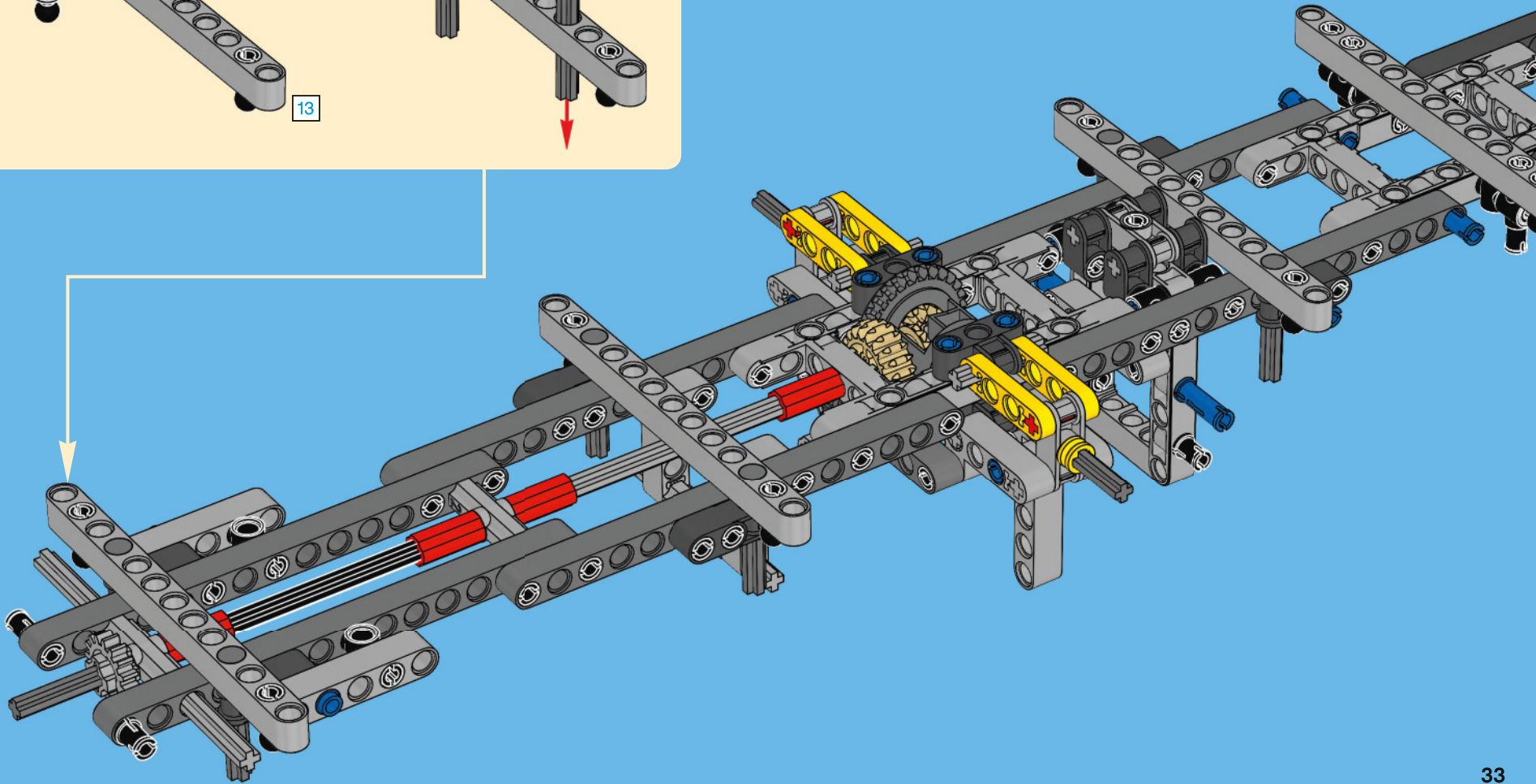
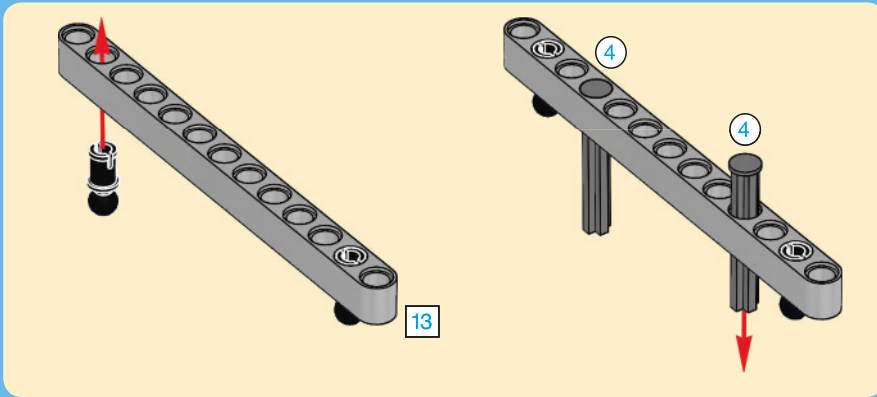



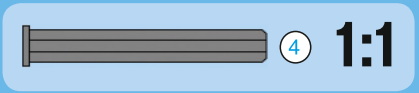
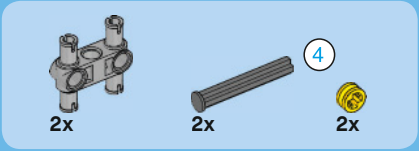

# 34

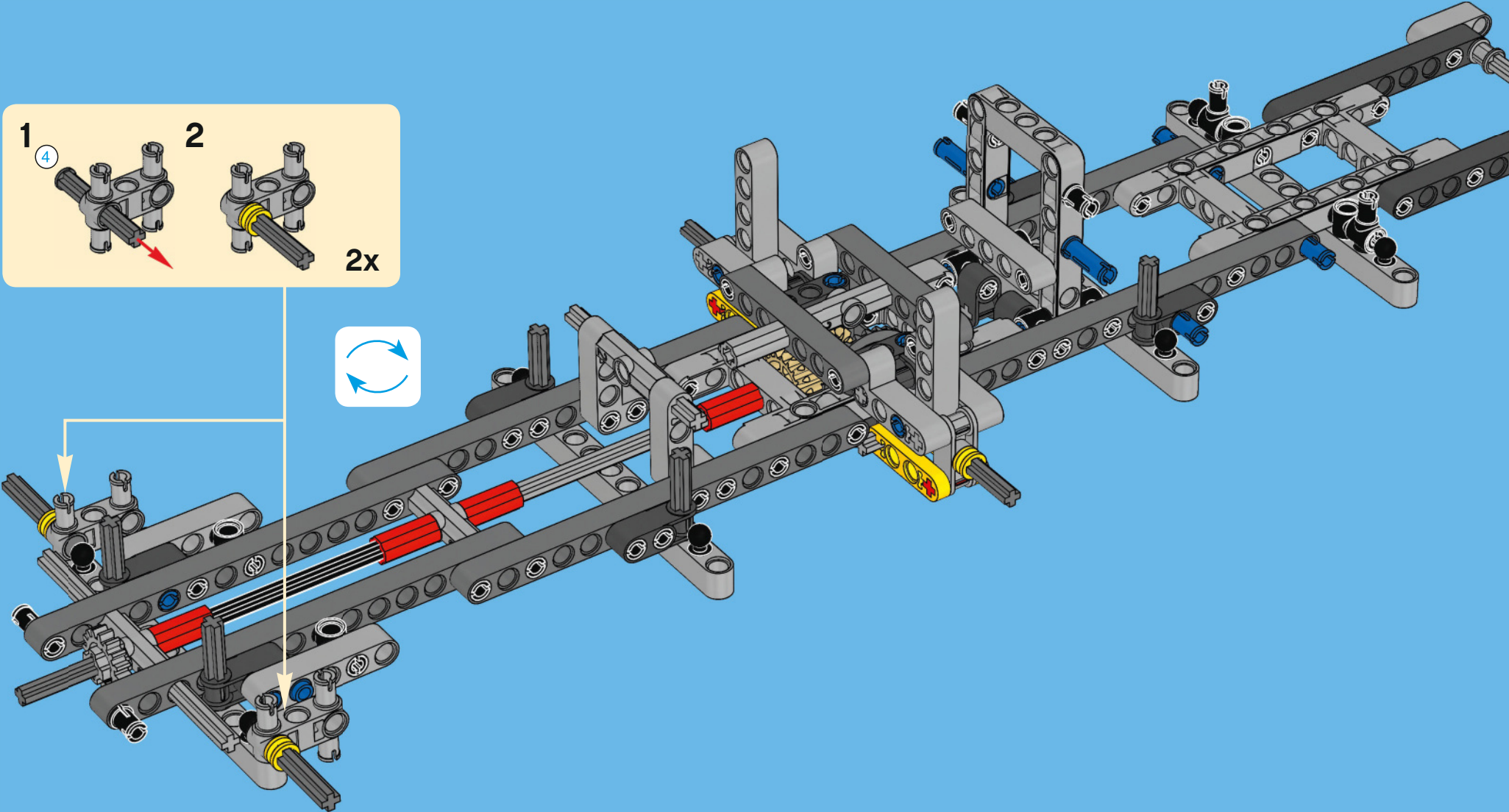
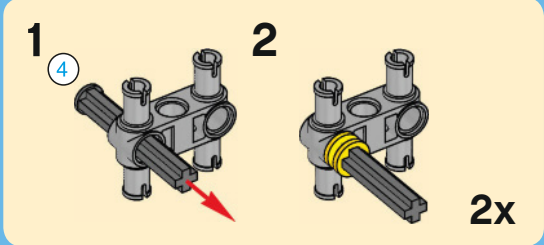

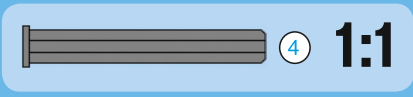
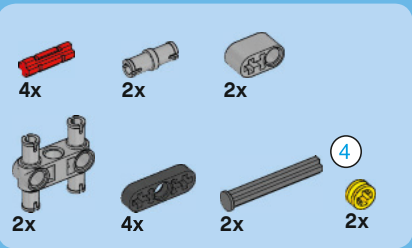

# 35

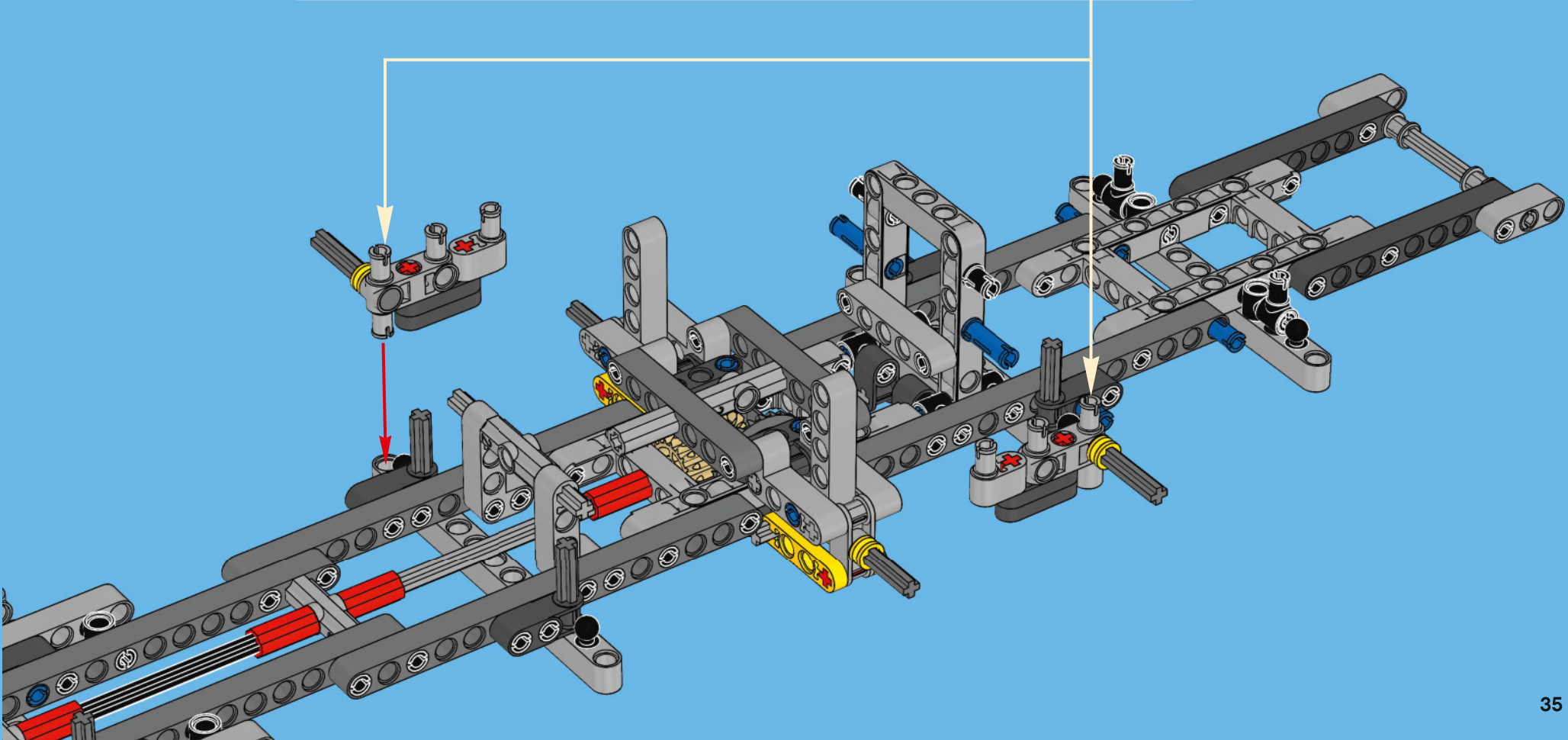
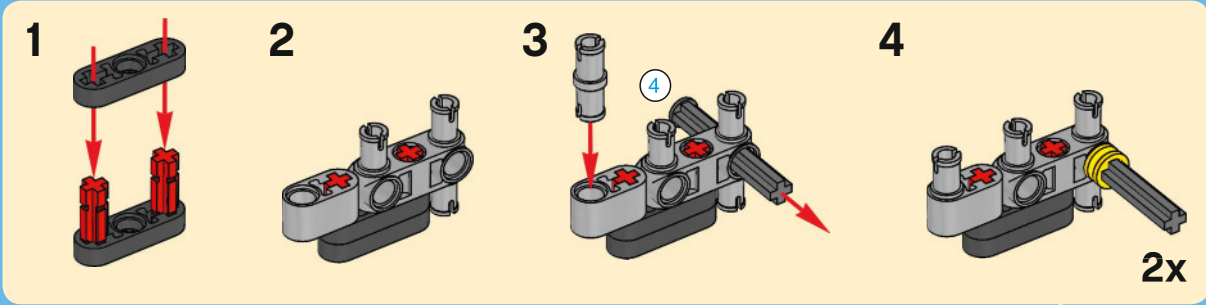



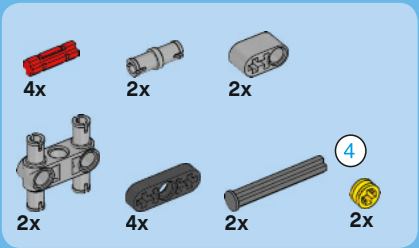

36

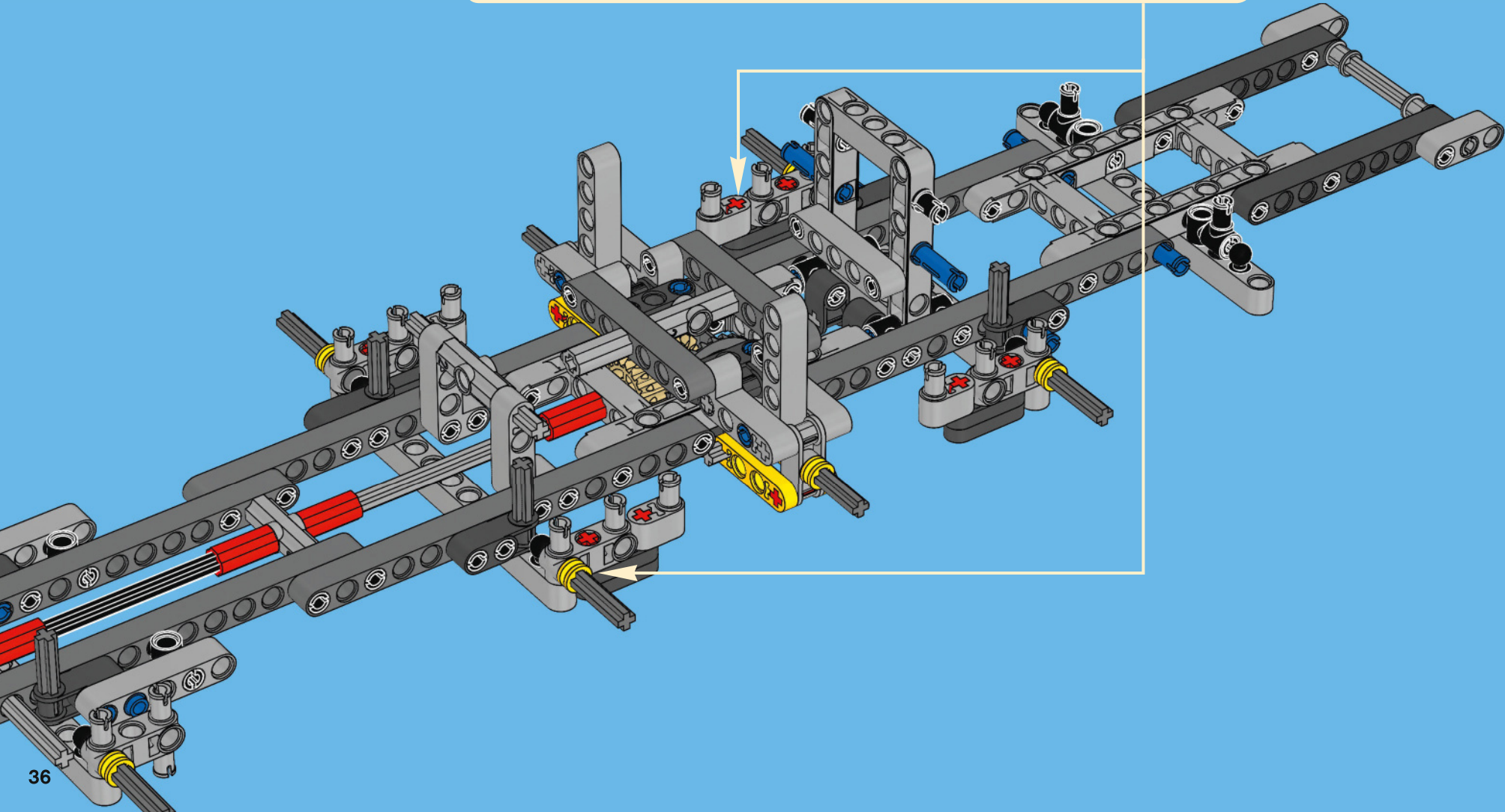
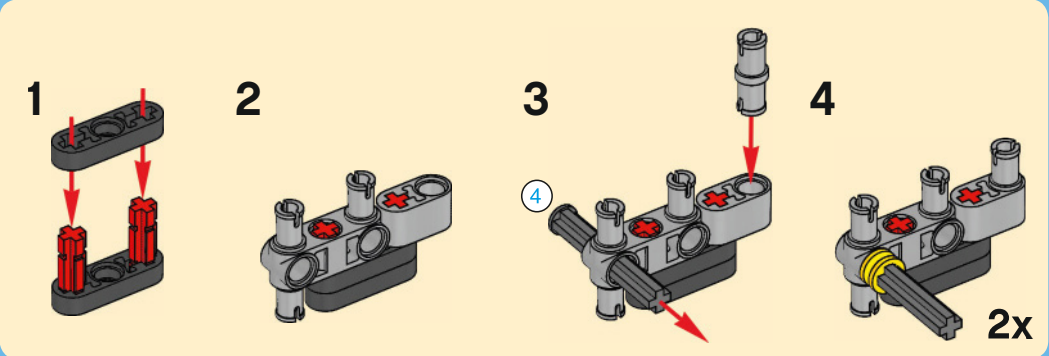



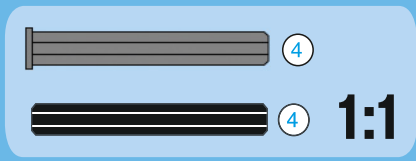
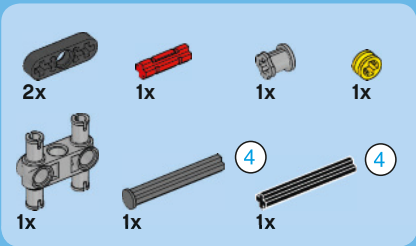

37

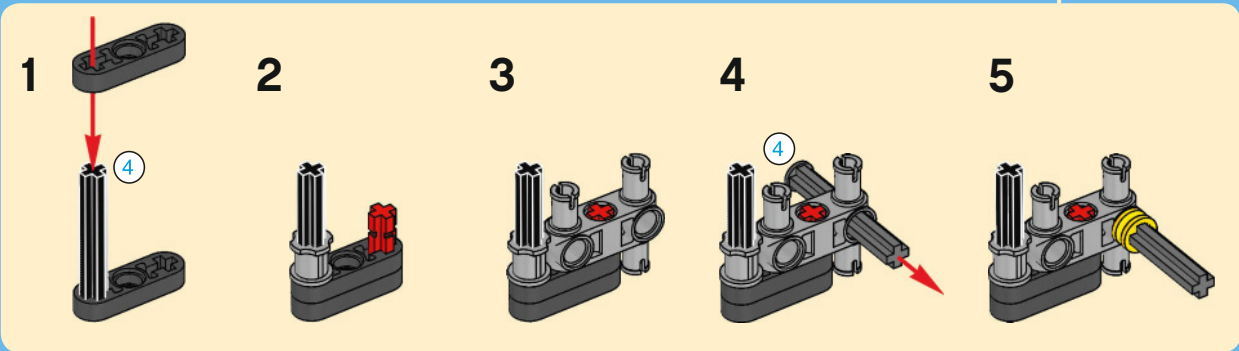
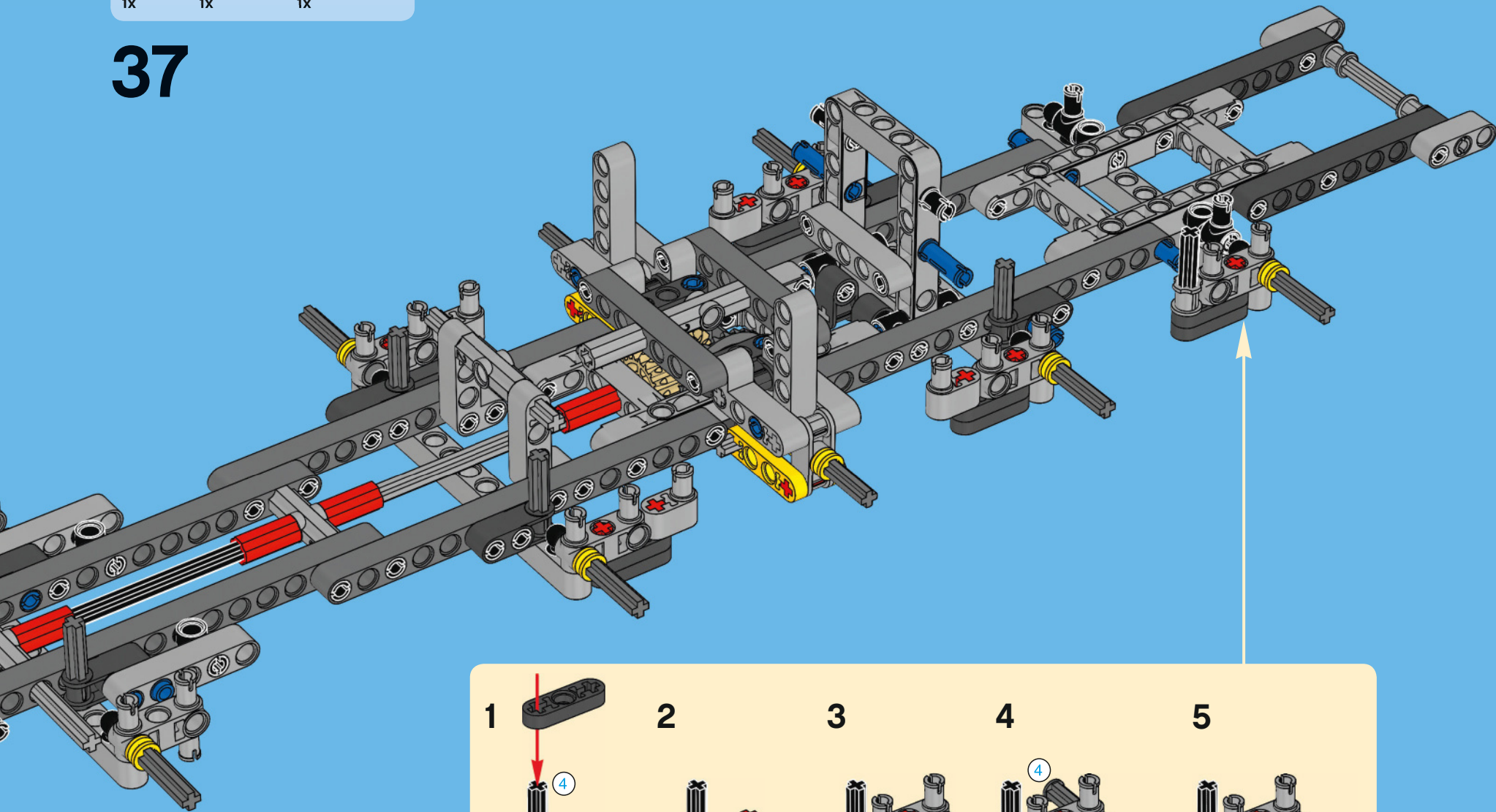

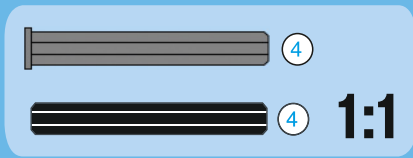
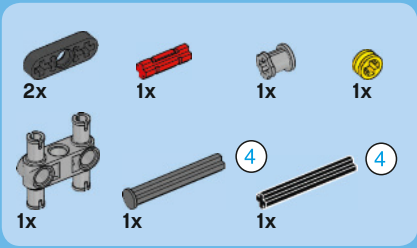

38

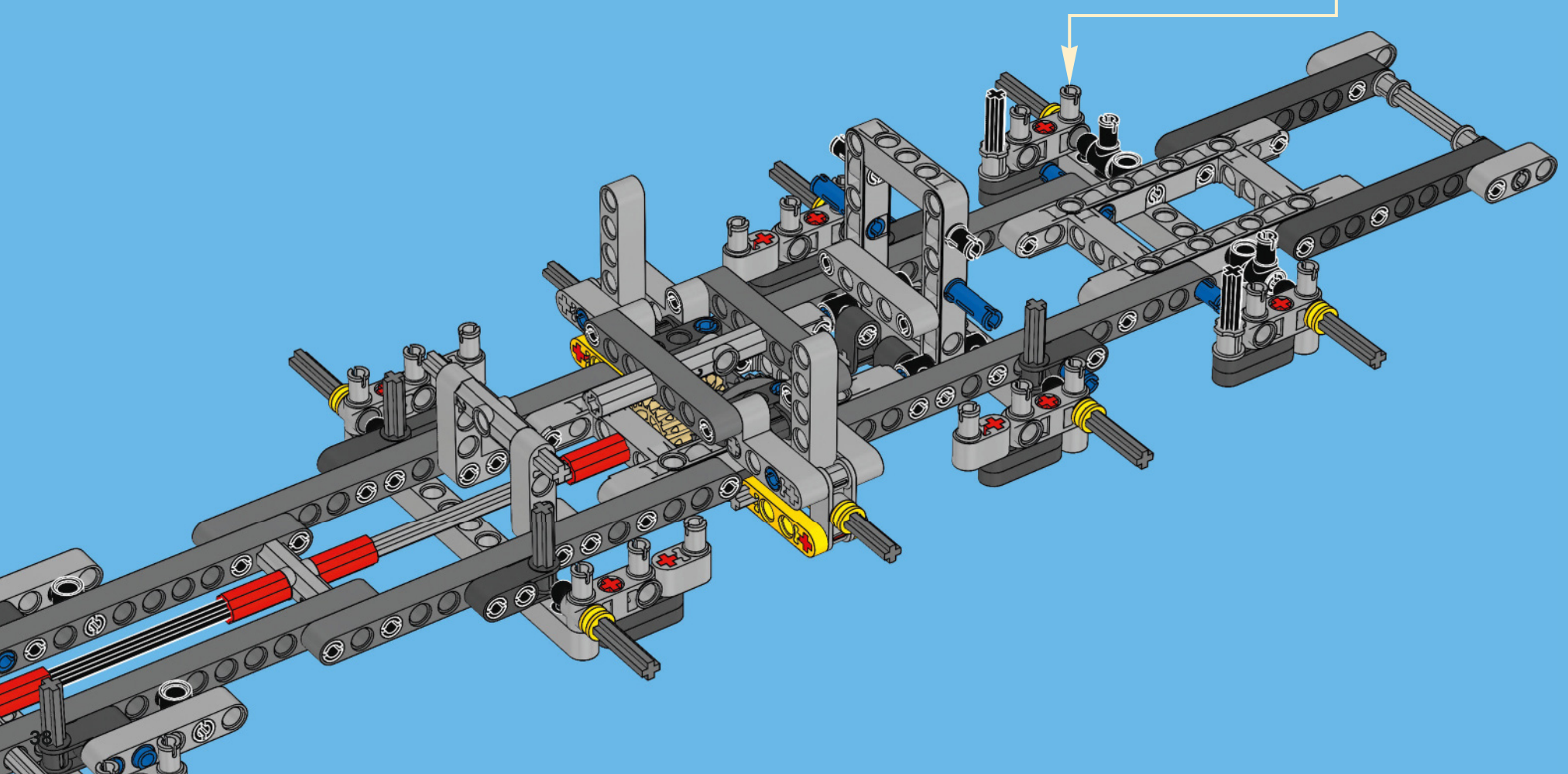
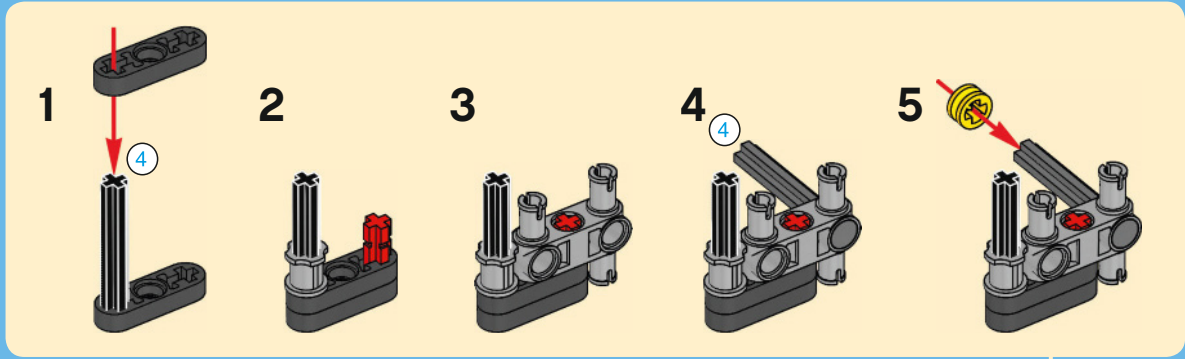



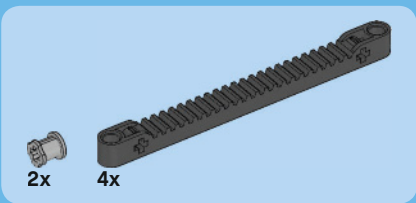

# 39

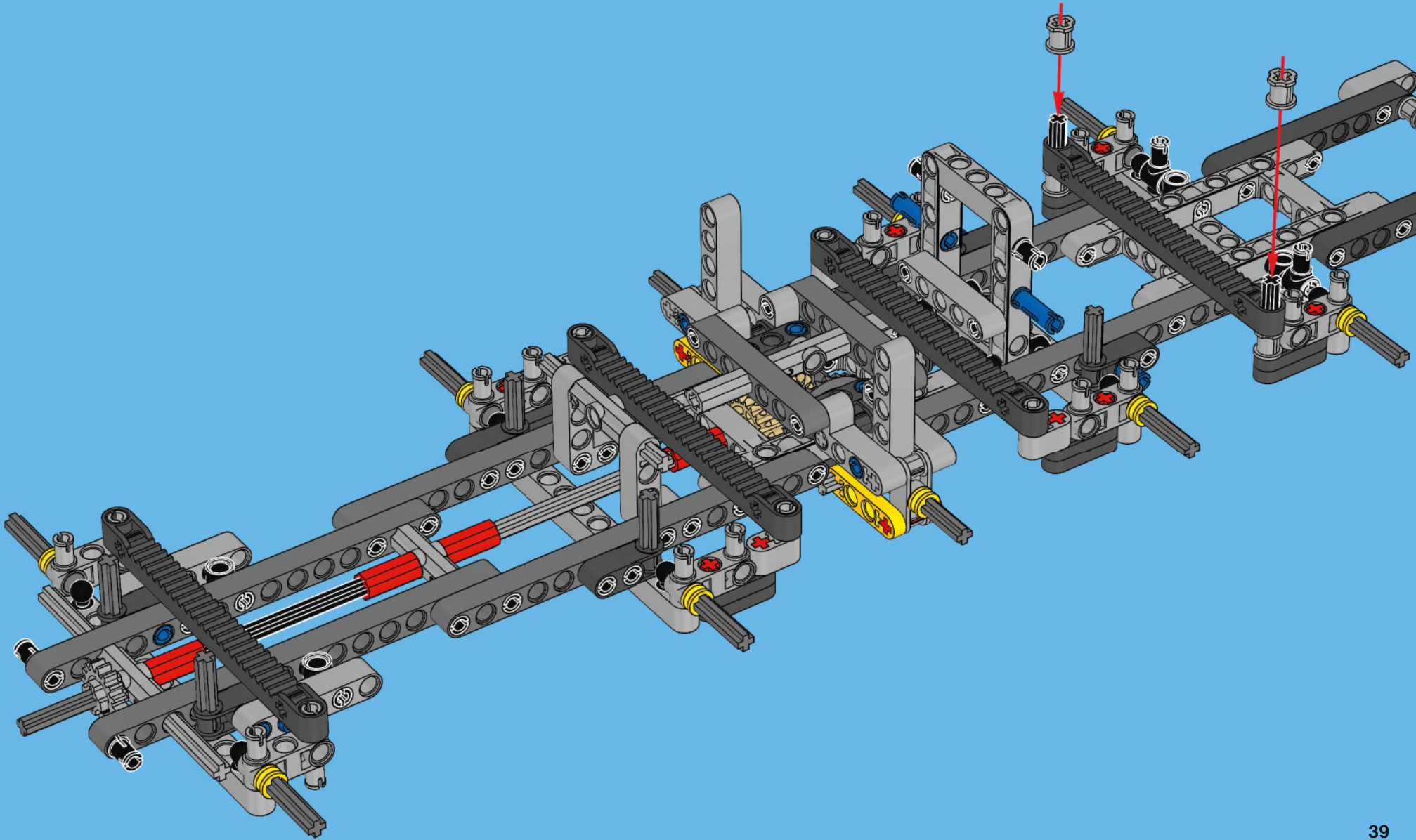



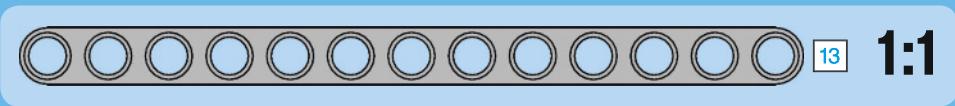
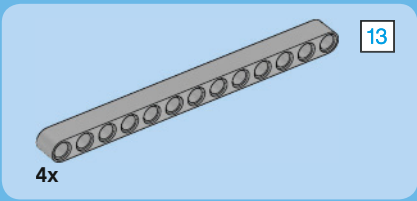

# 40

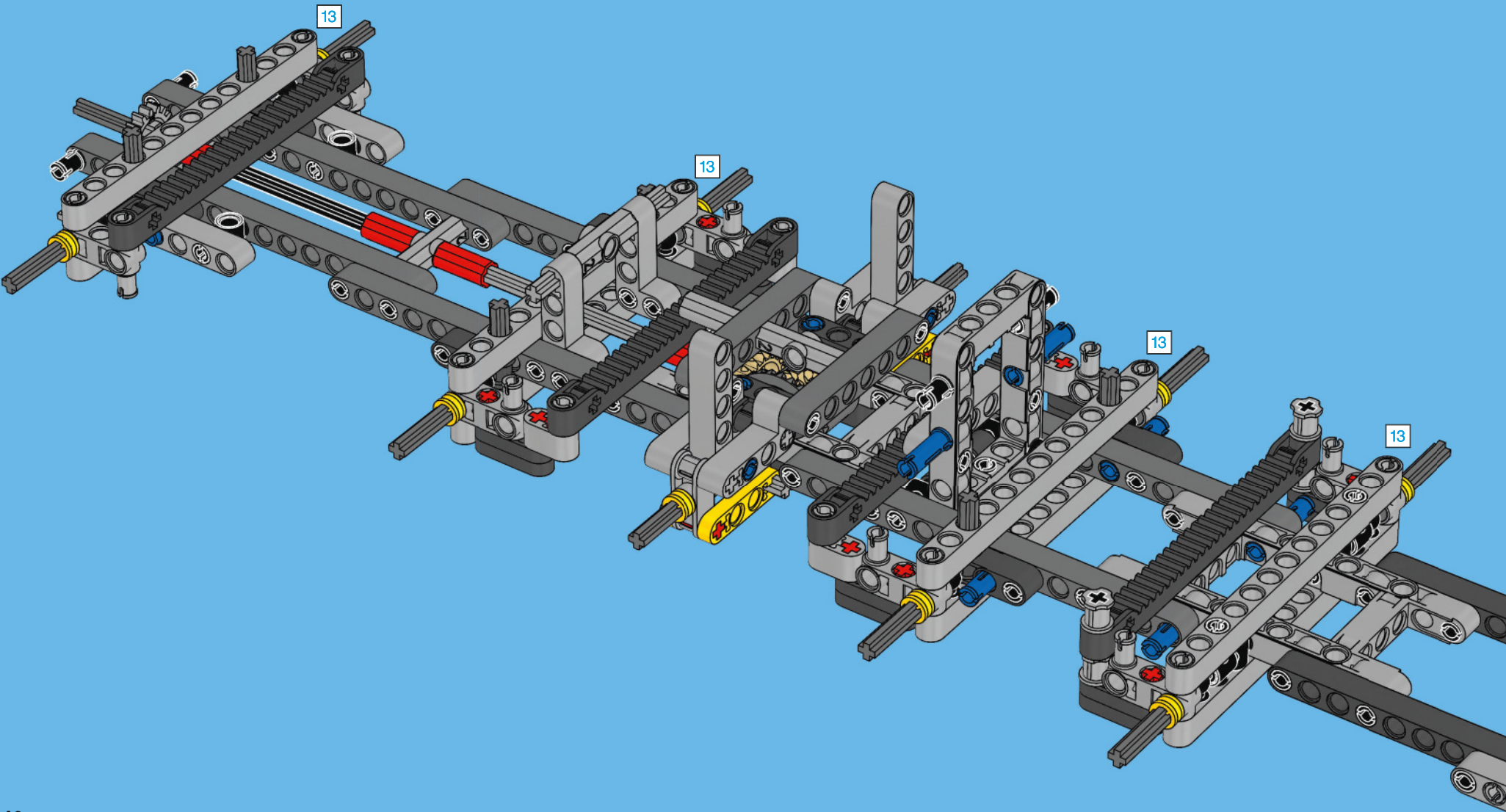

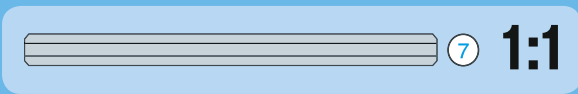
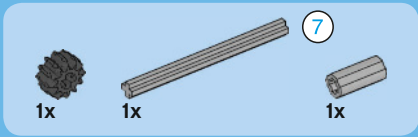

41

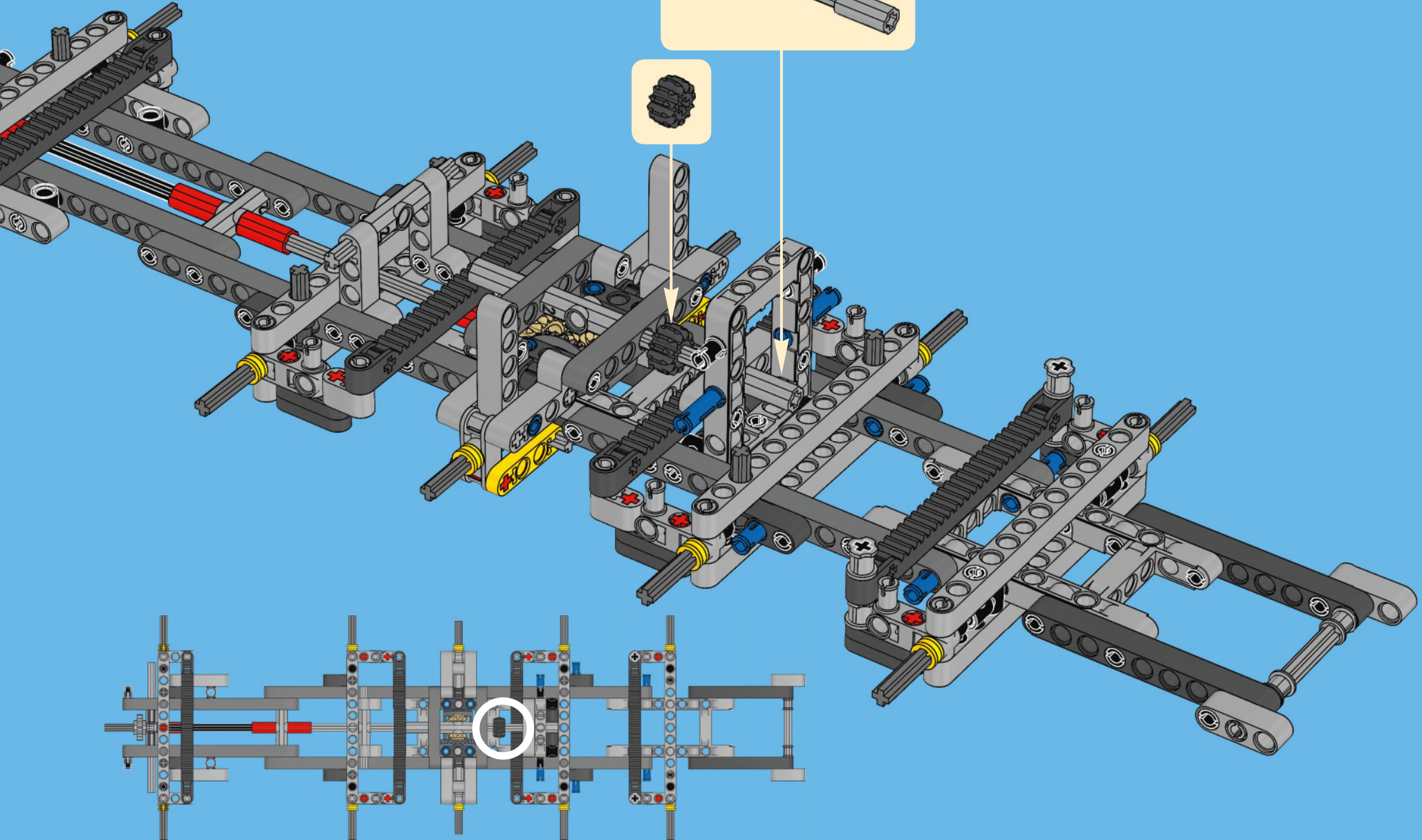
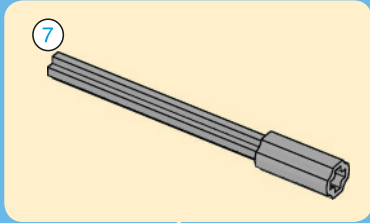





4x

# 42

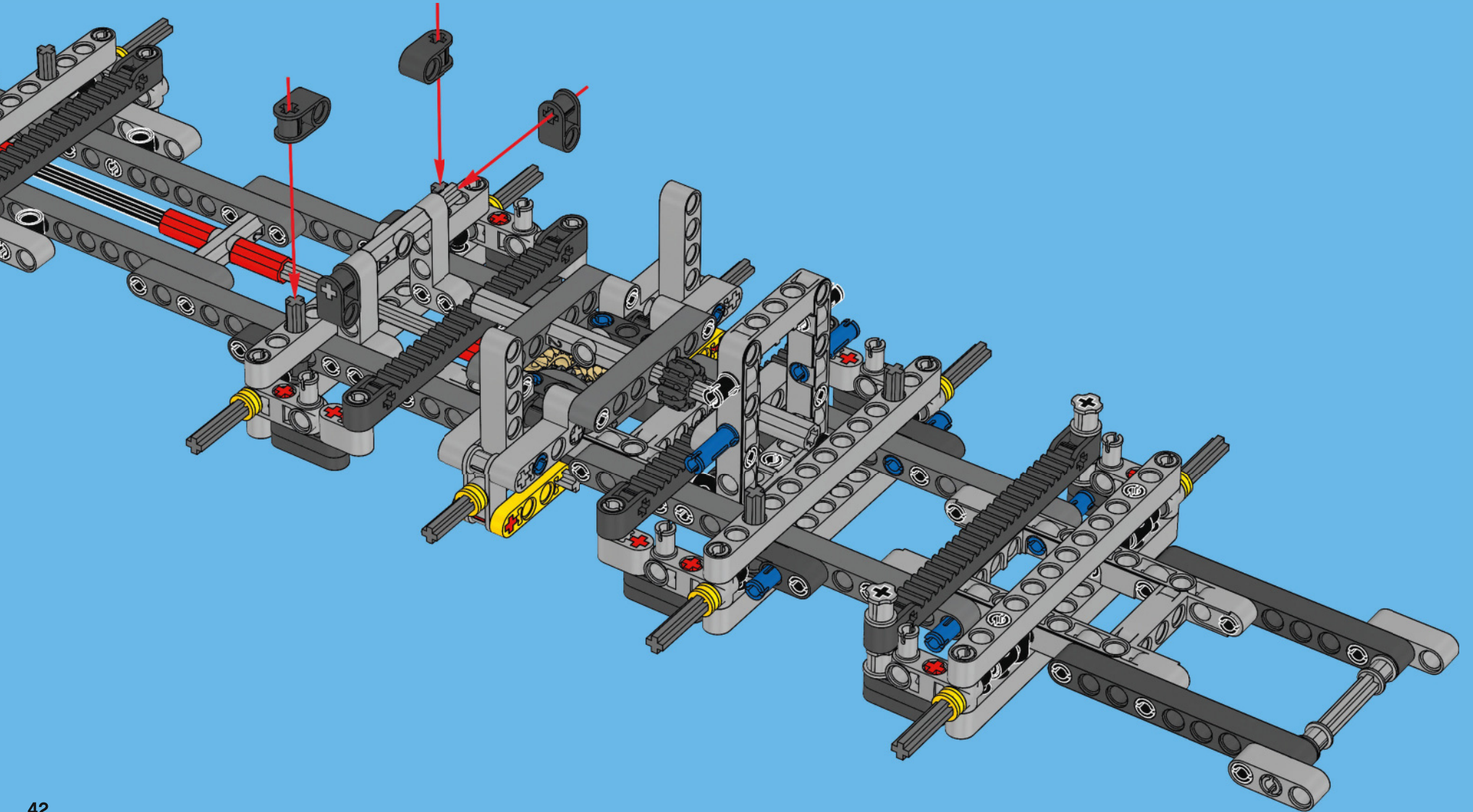





2x

# 43

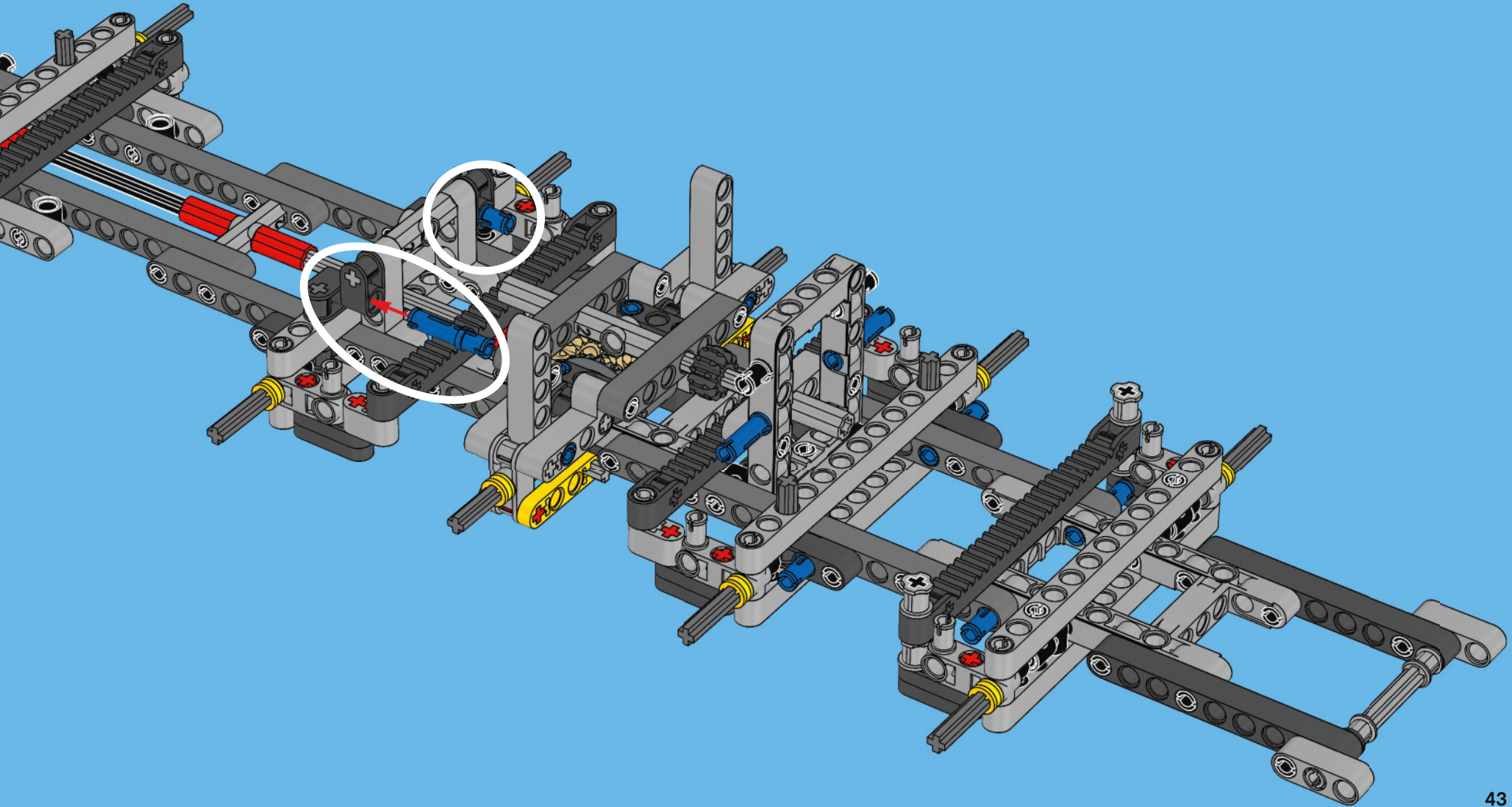

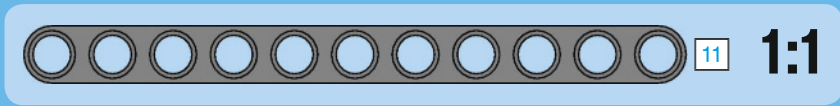
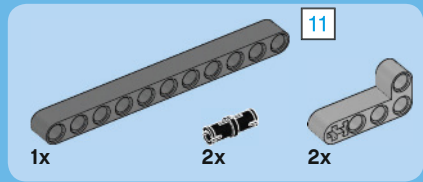

44

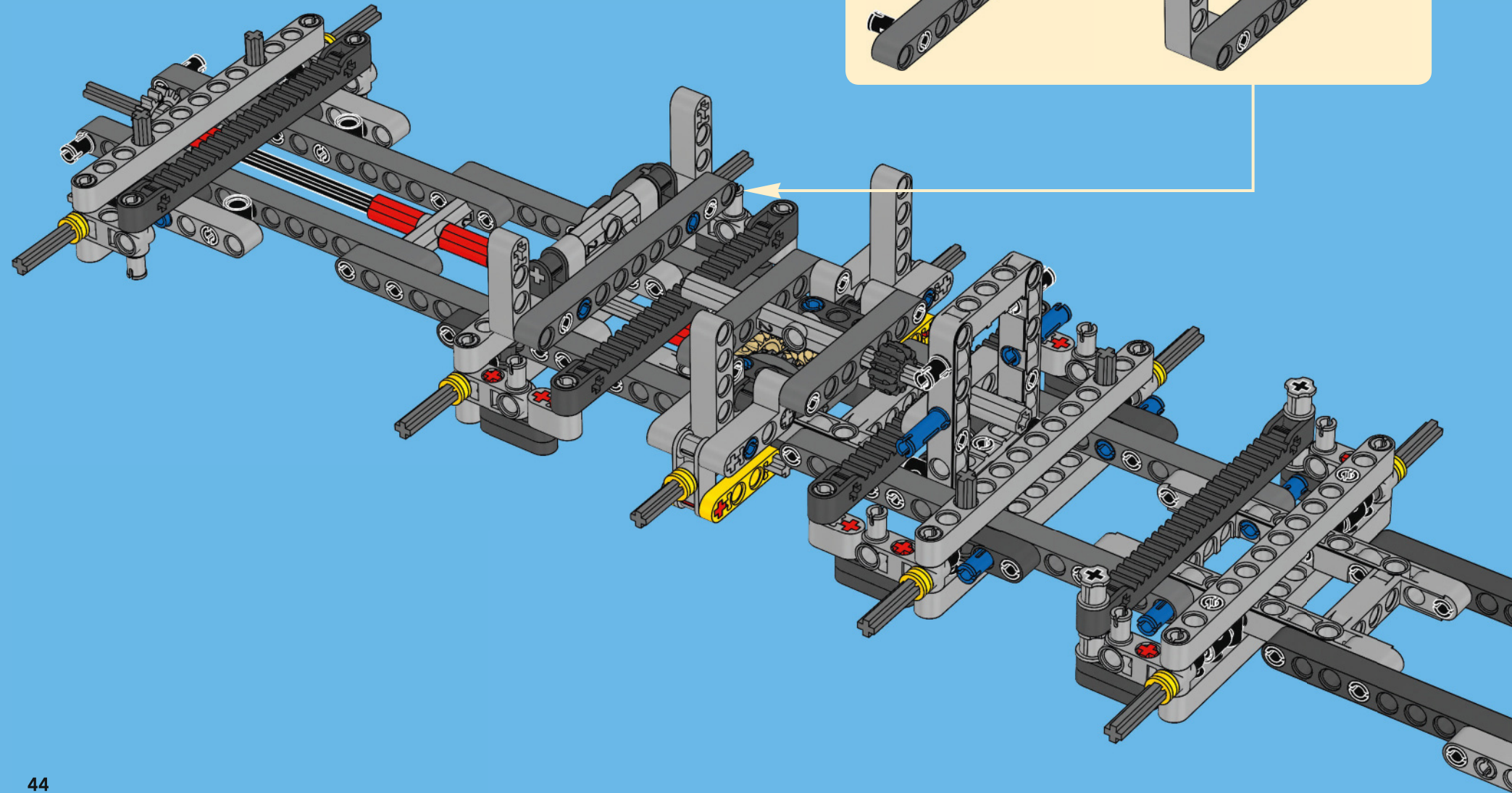
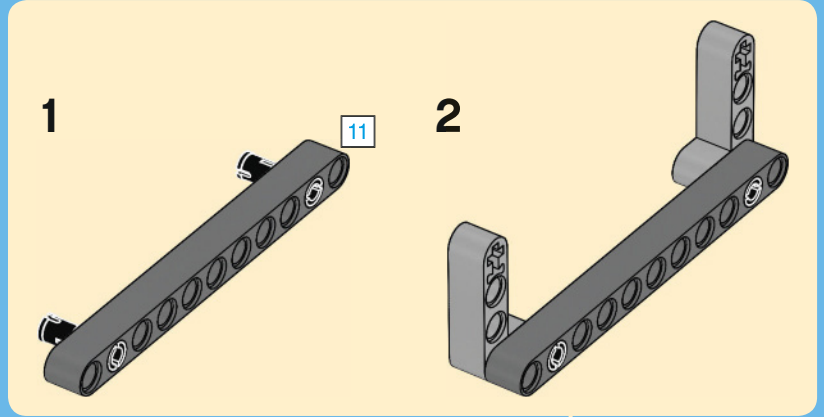



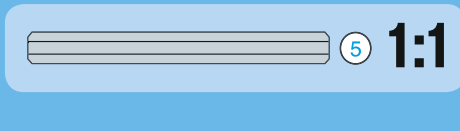
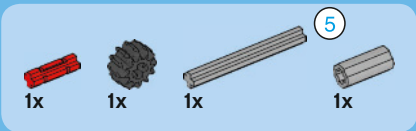

45

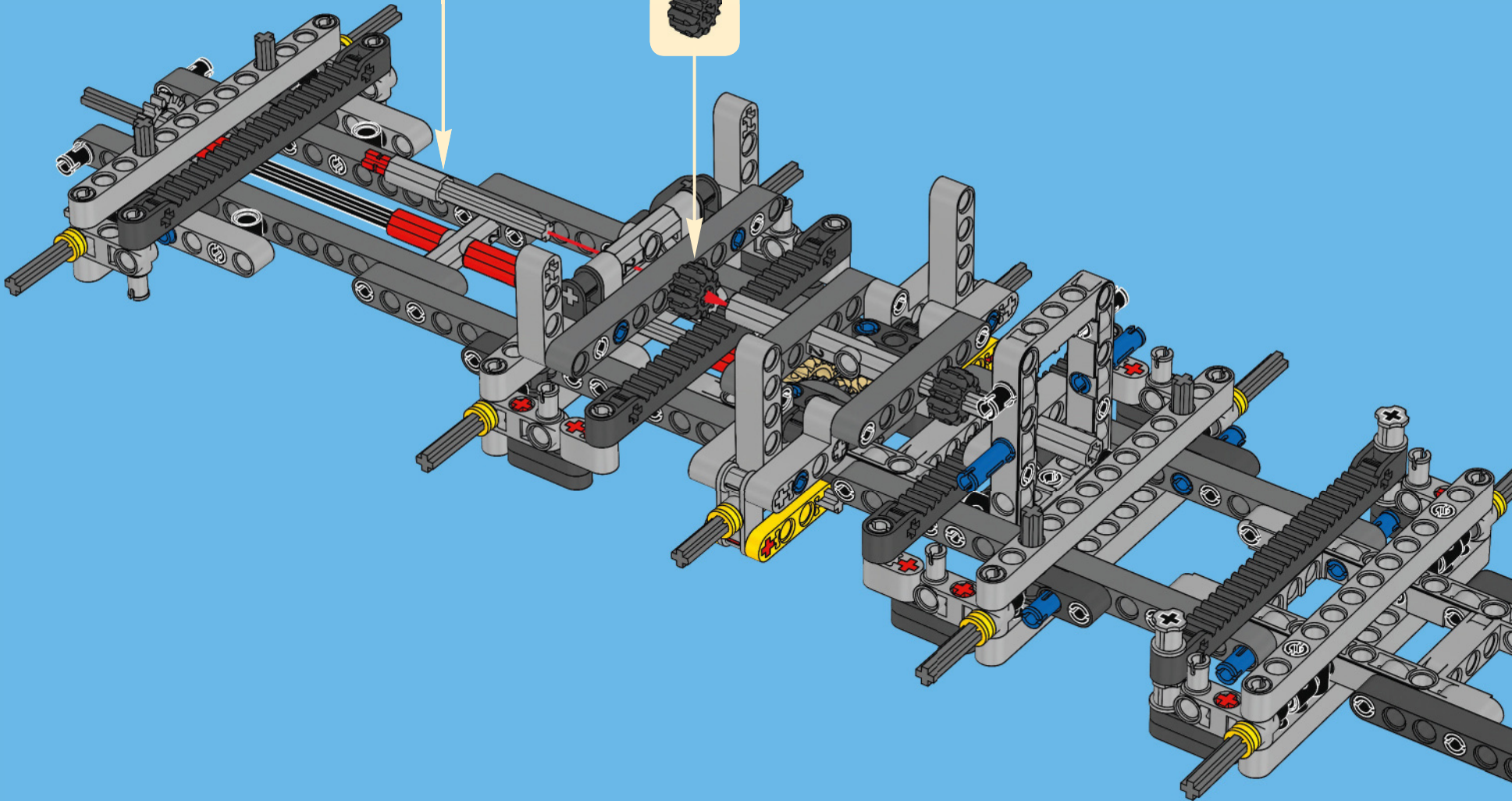
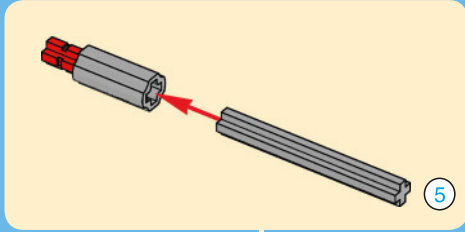



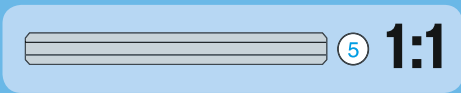
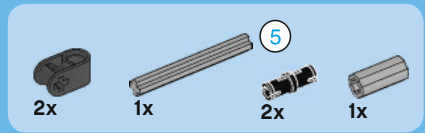

46

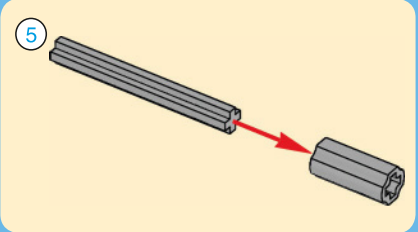
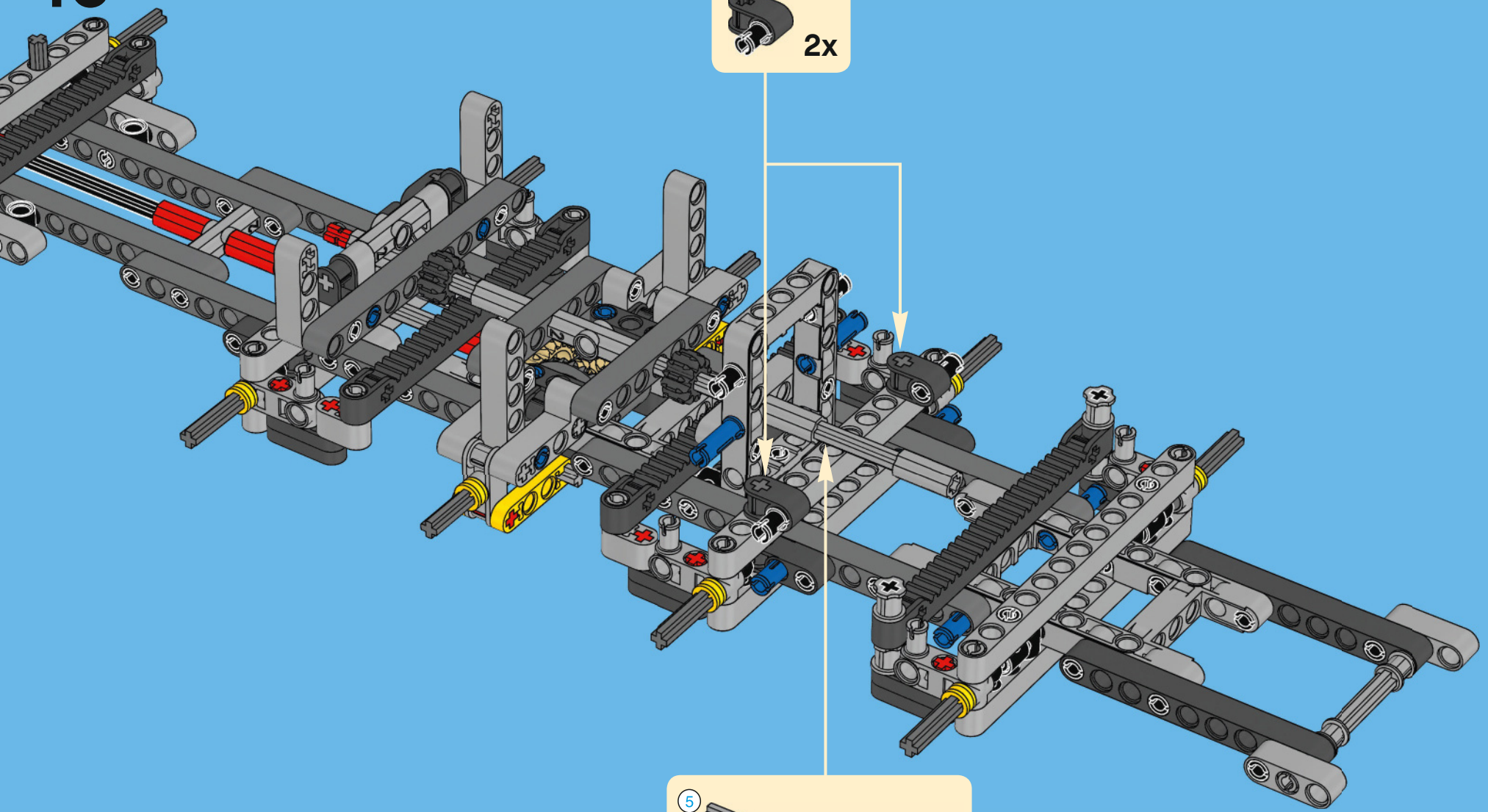

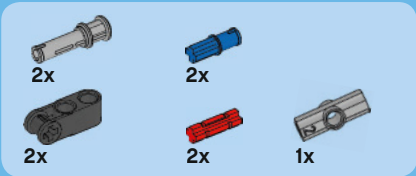

47

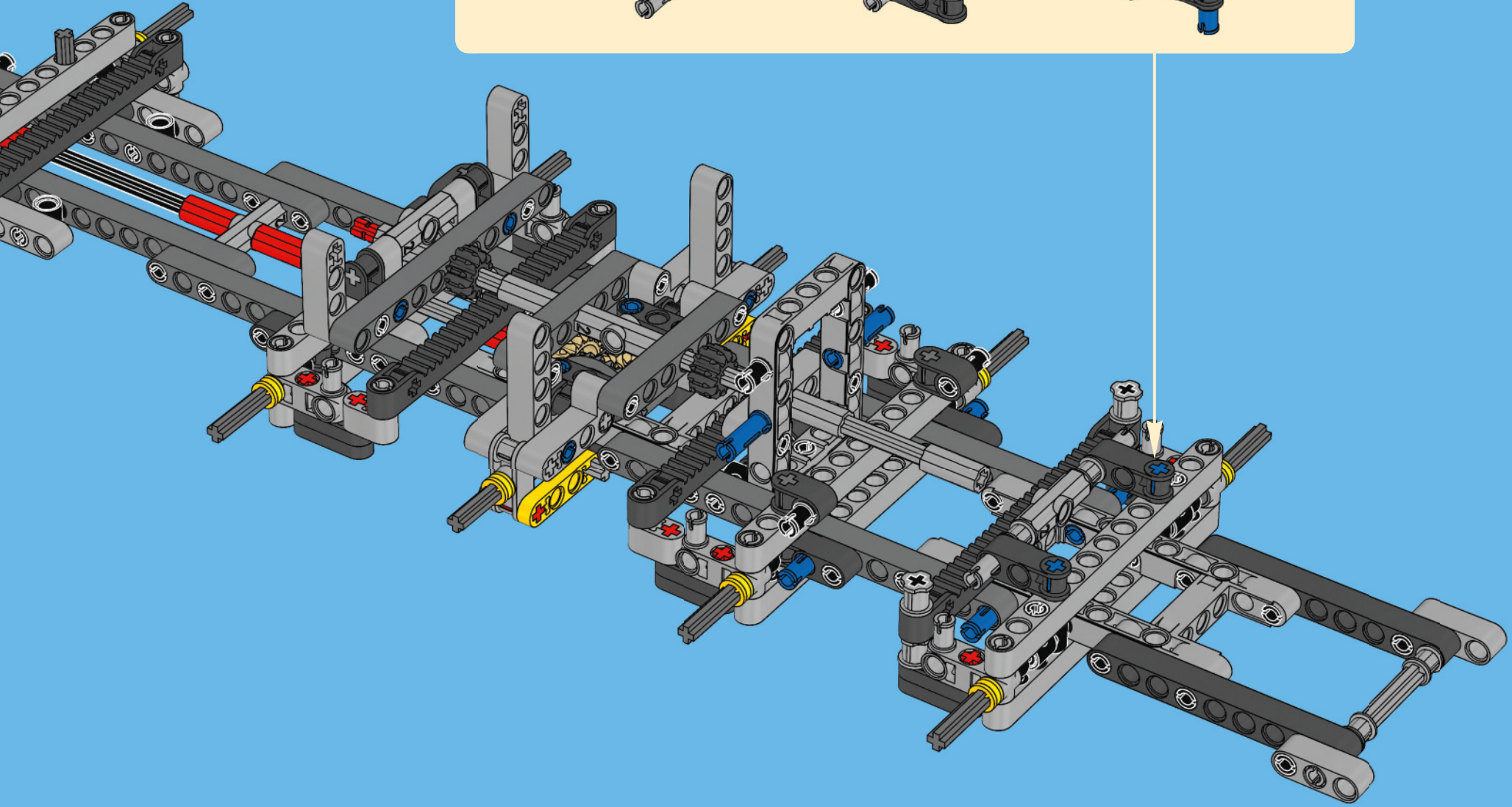
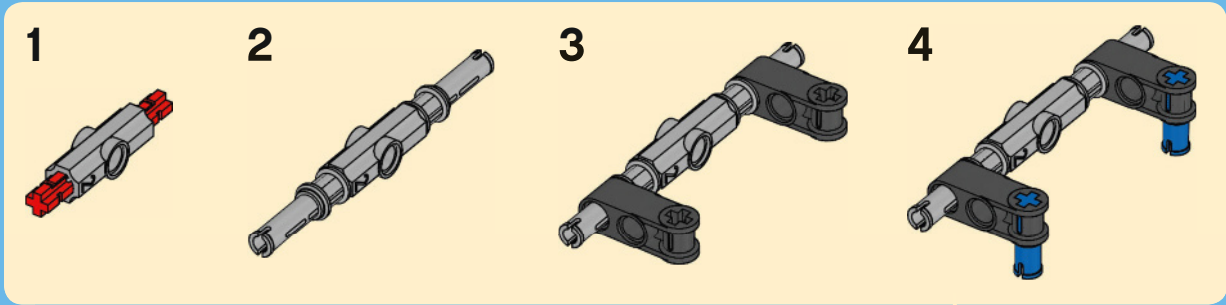



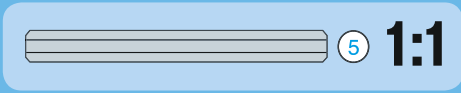
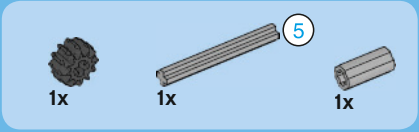

48

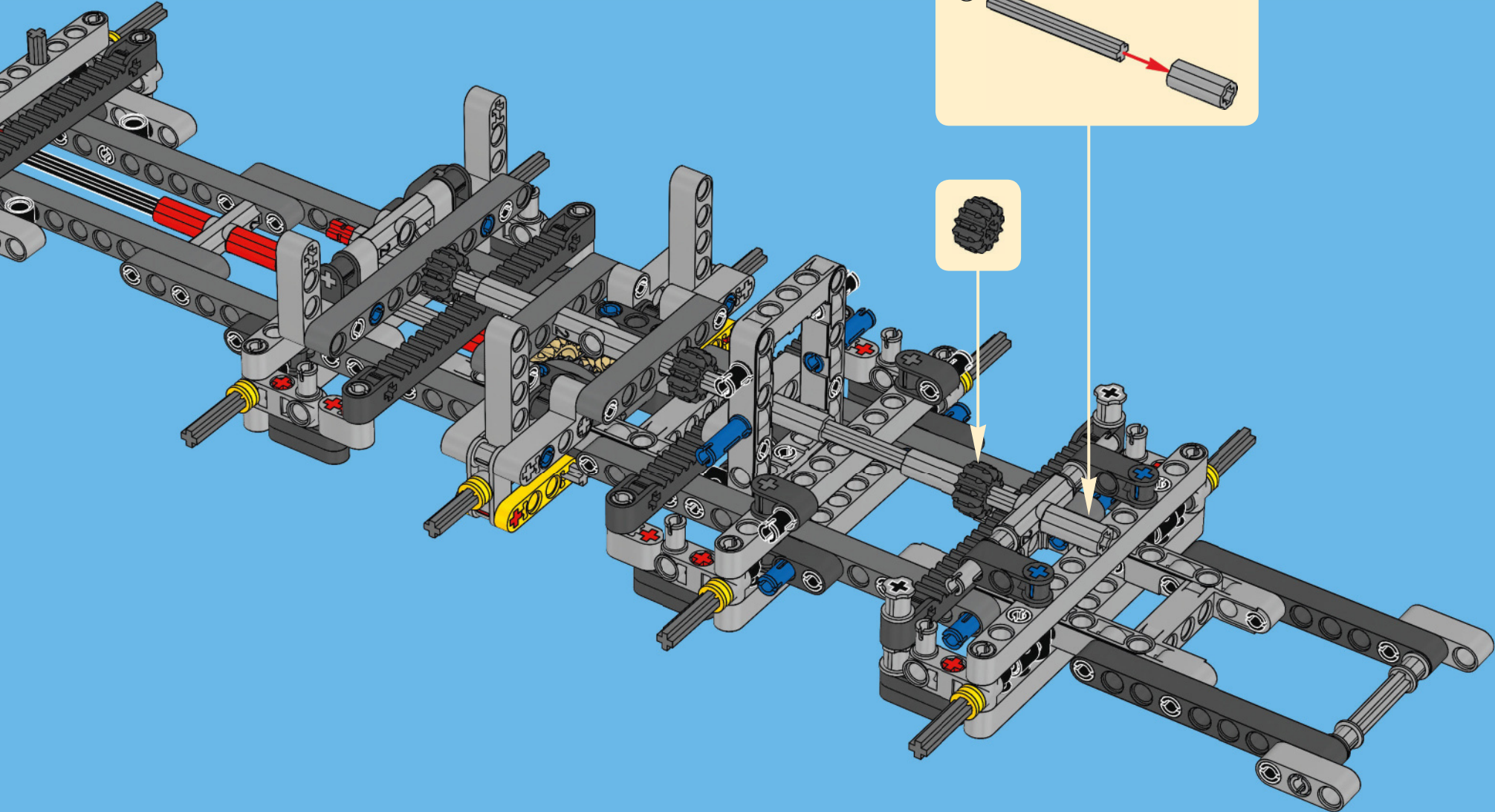





1x



1x

# 49

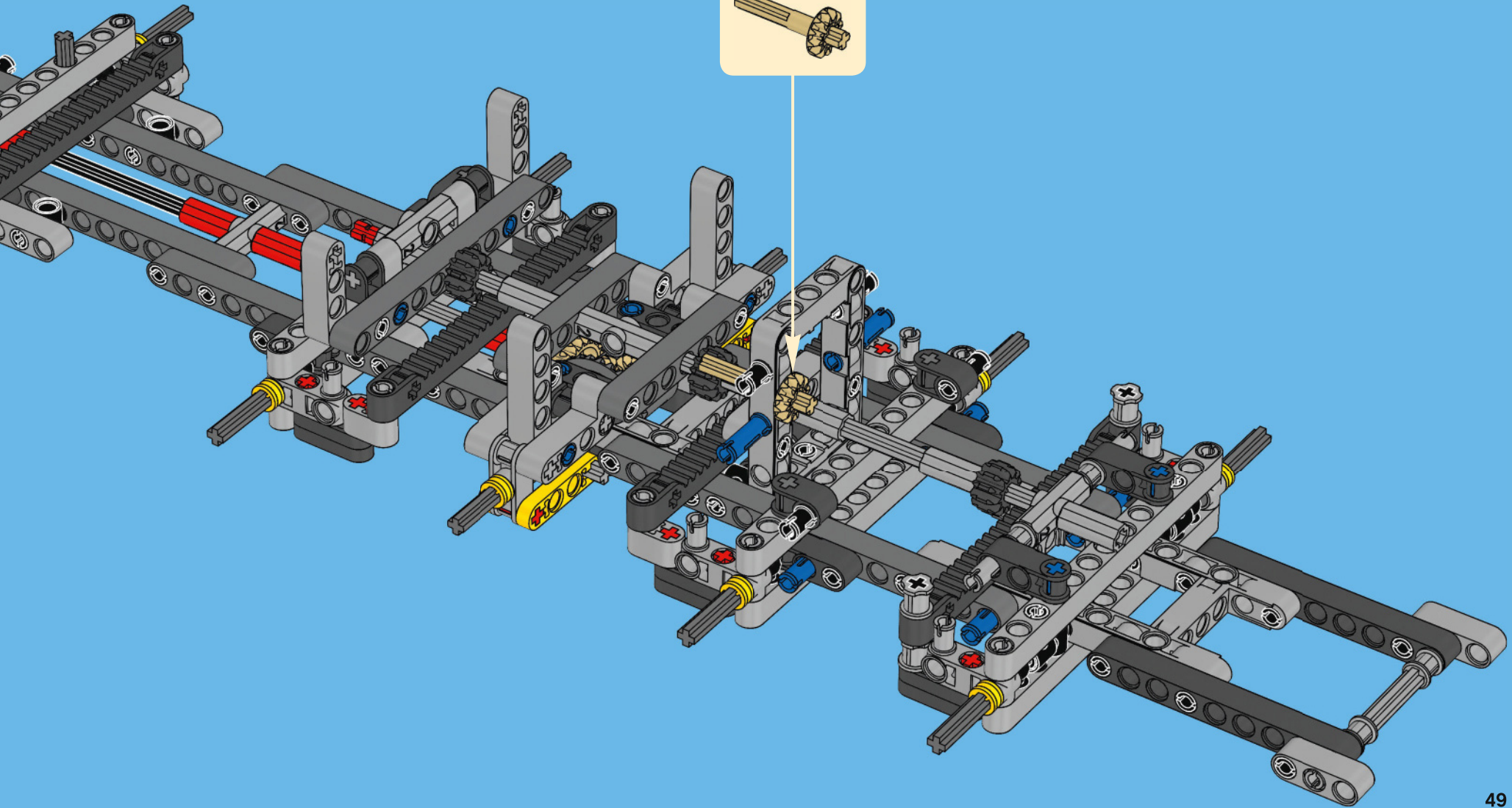
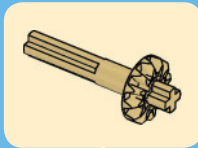

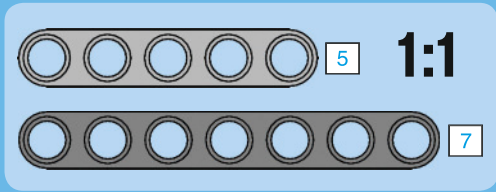
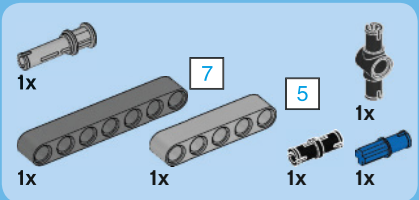

50

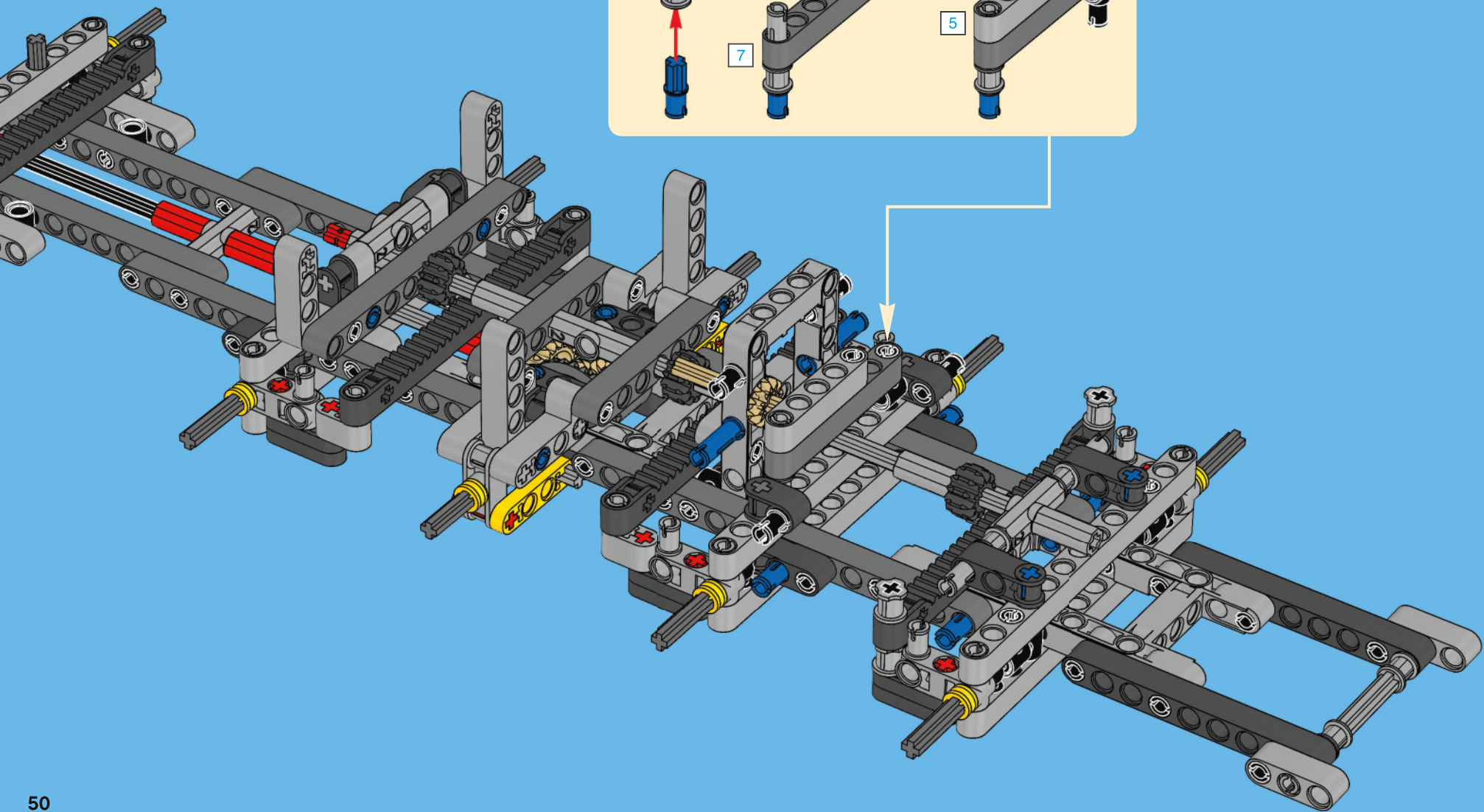
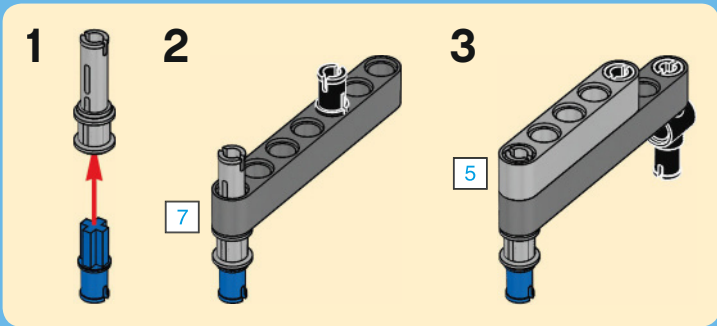

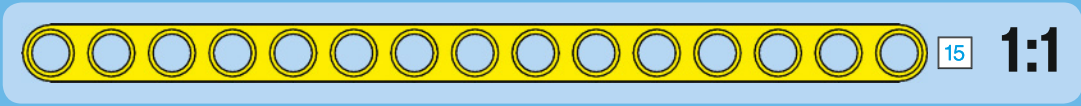
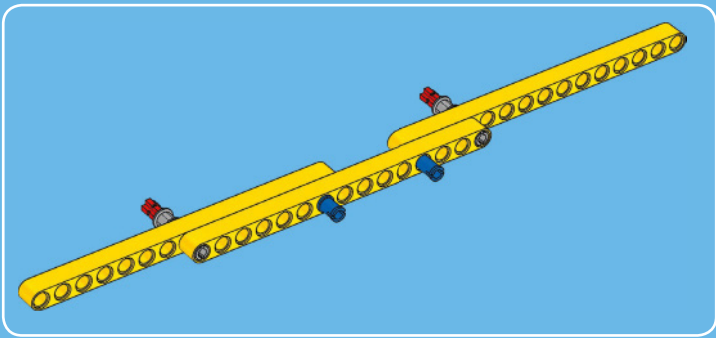

1

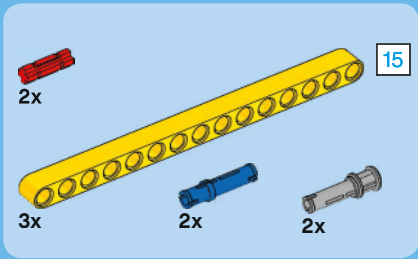
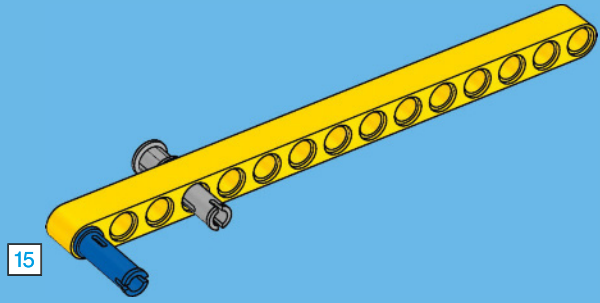

51

2

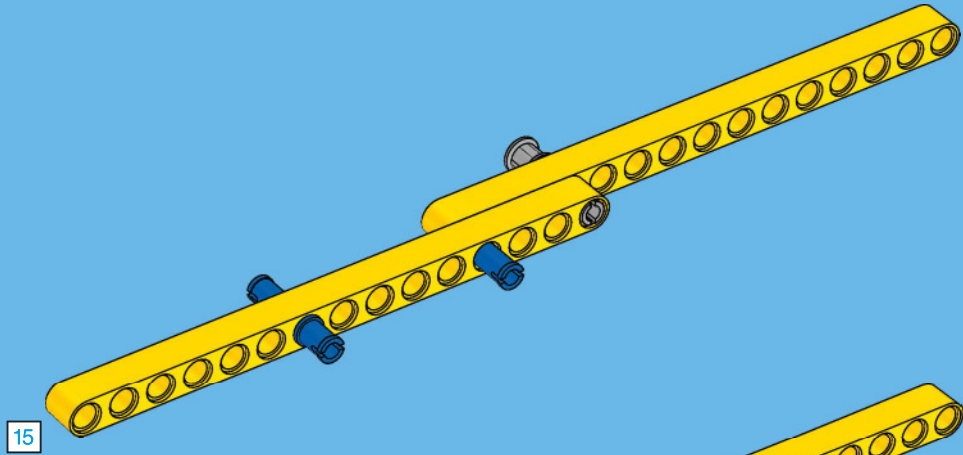

3

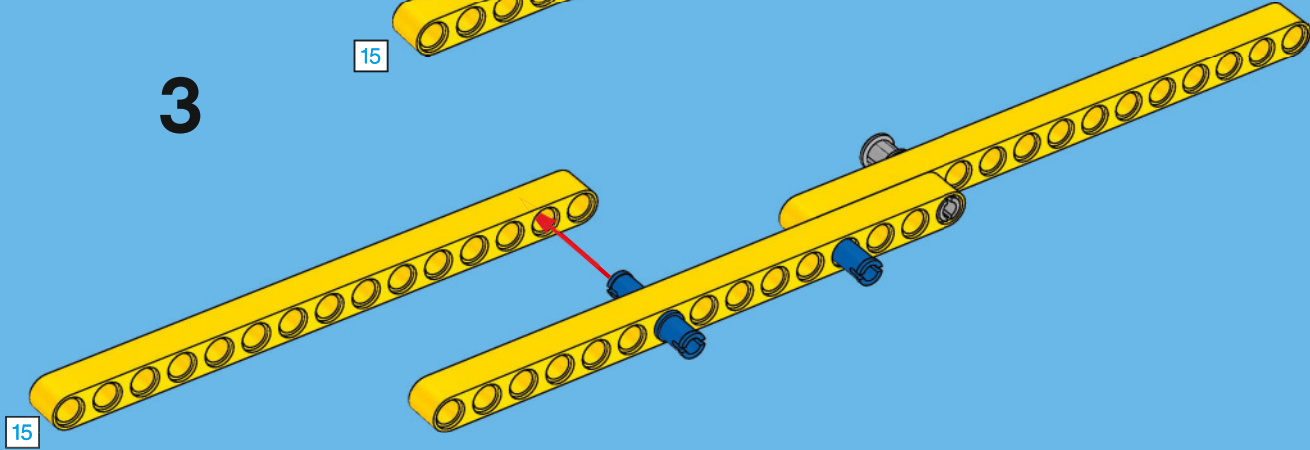



4

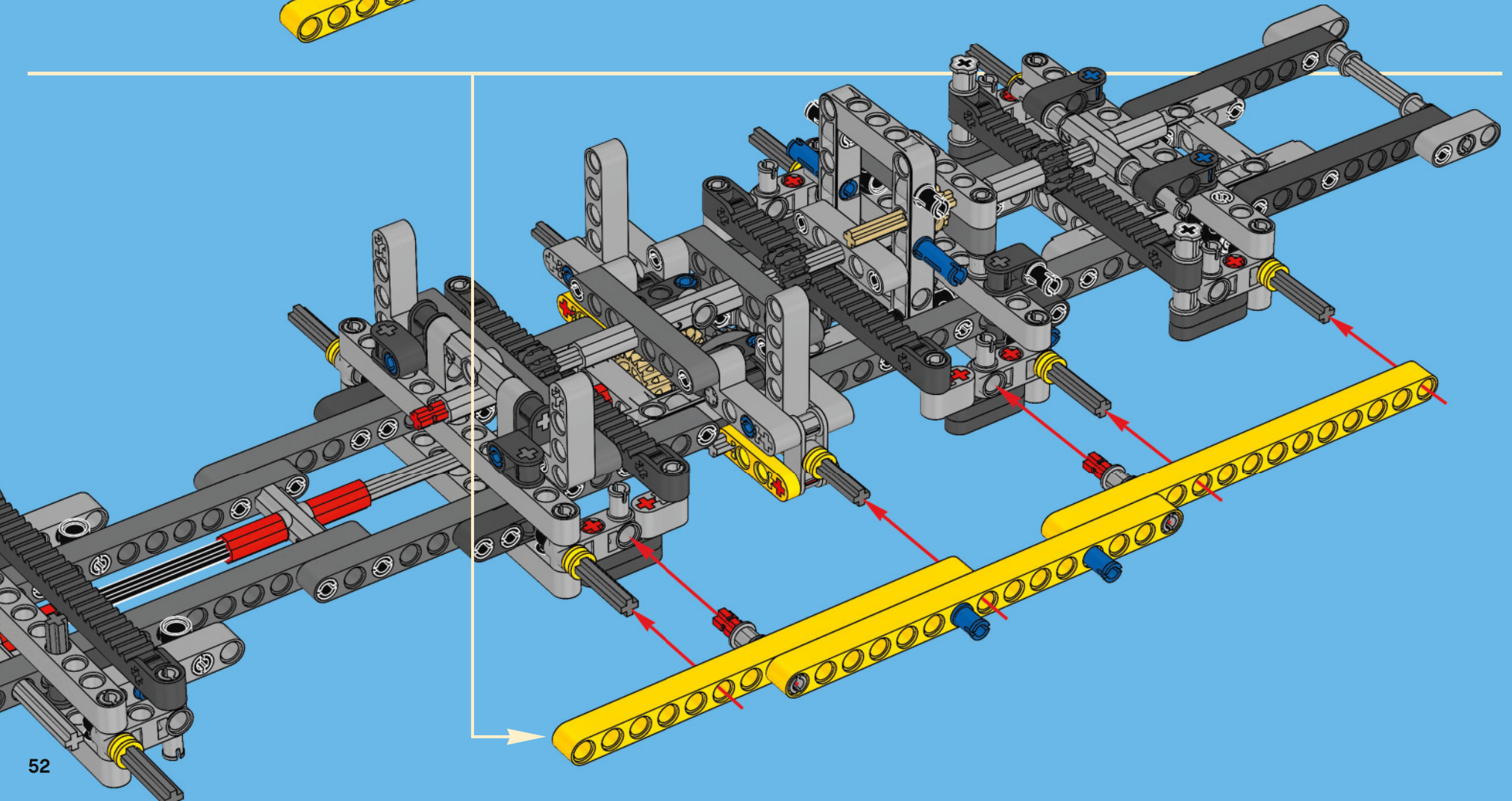
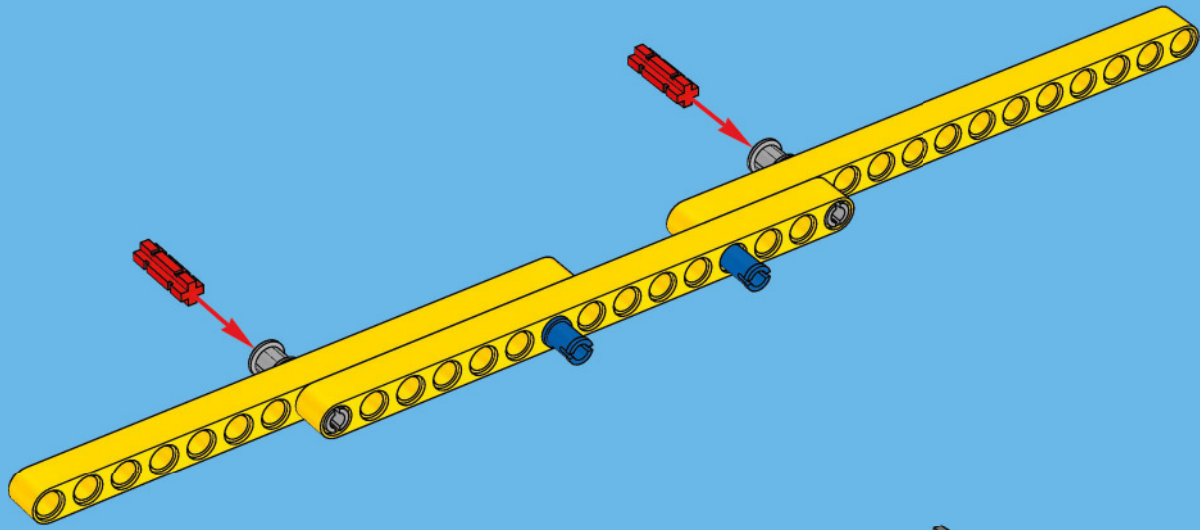

52

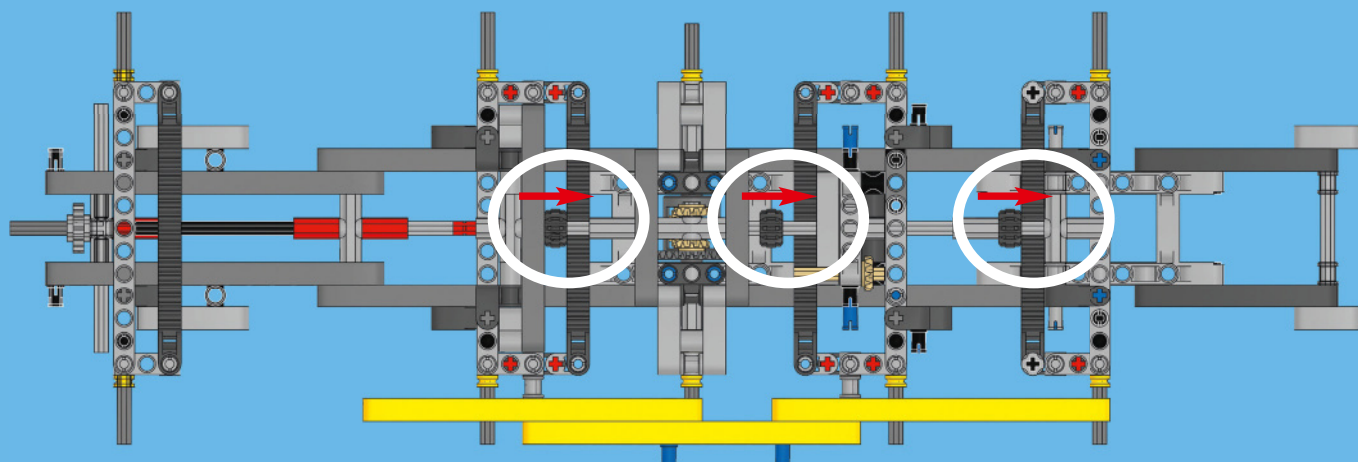
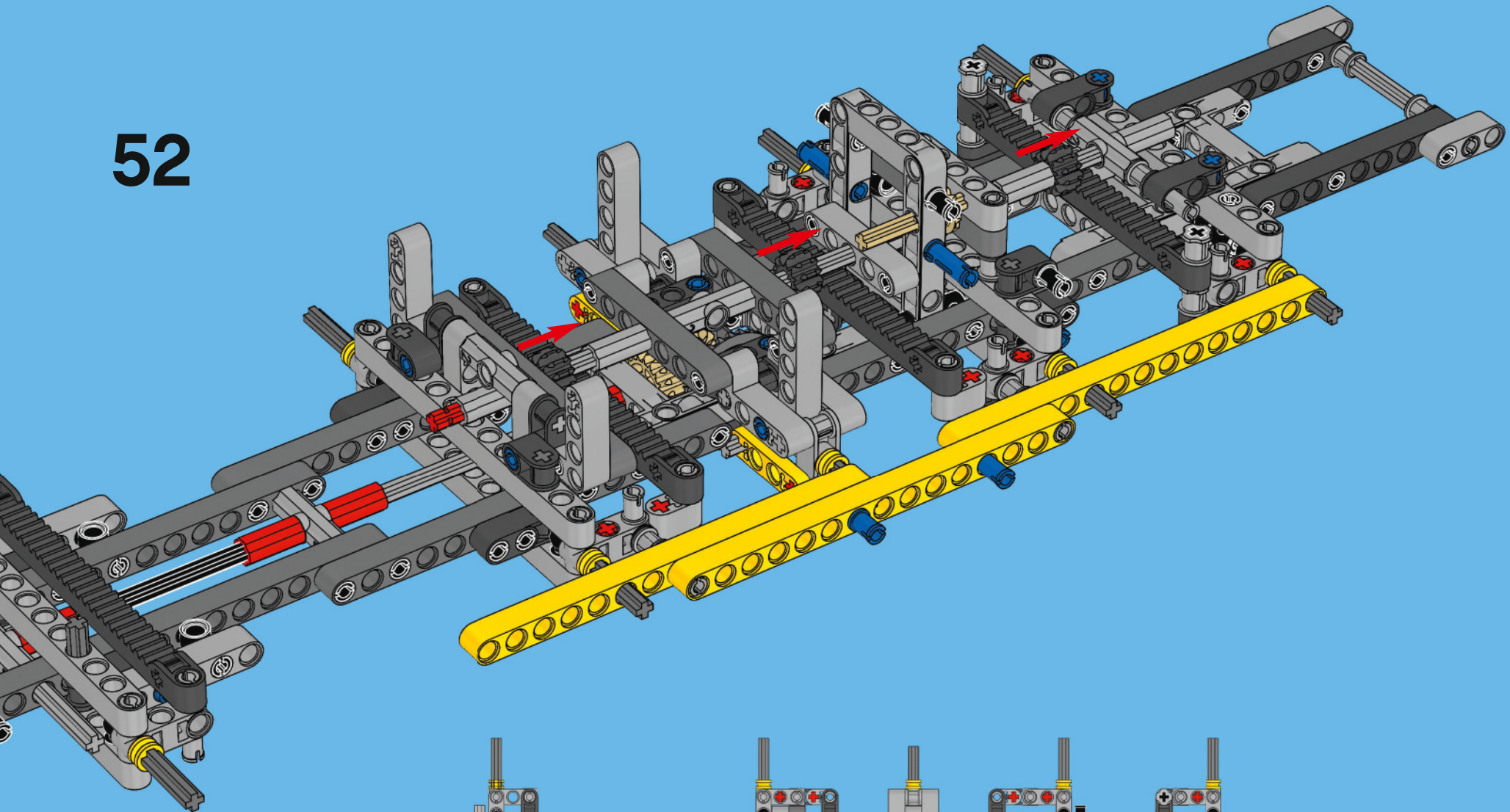



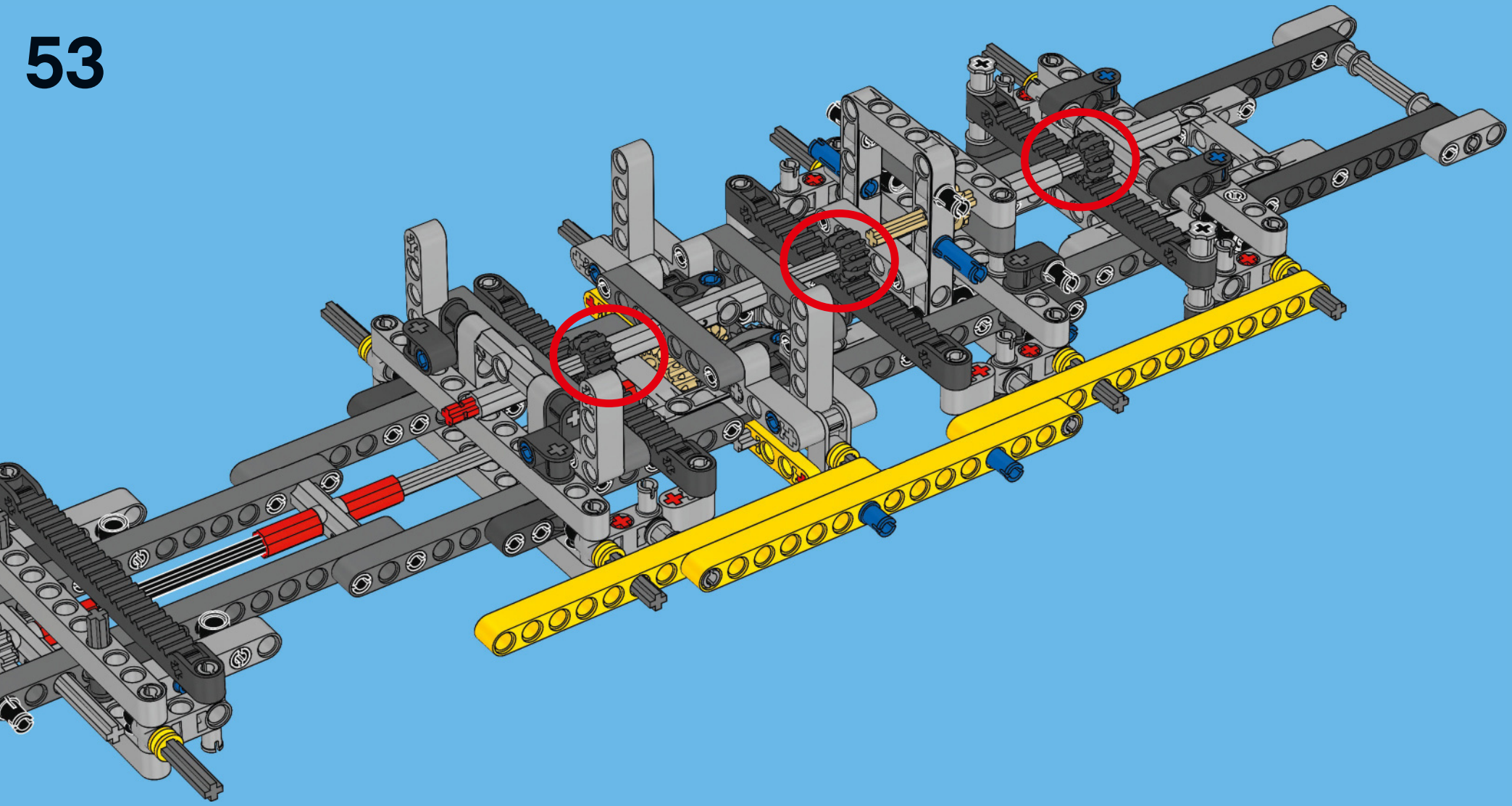



54

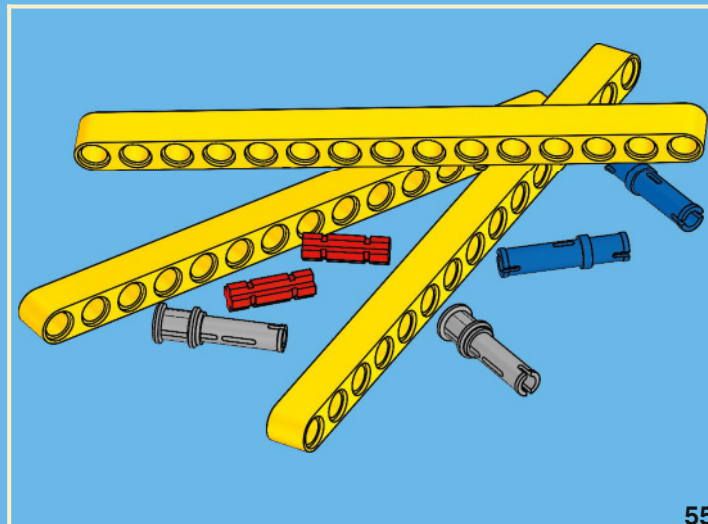
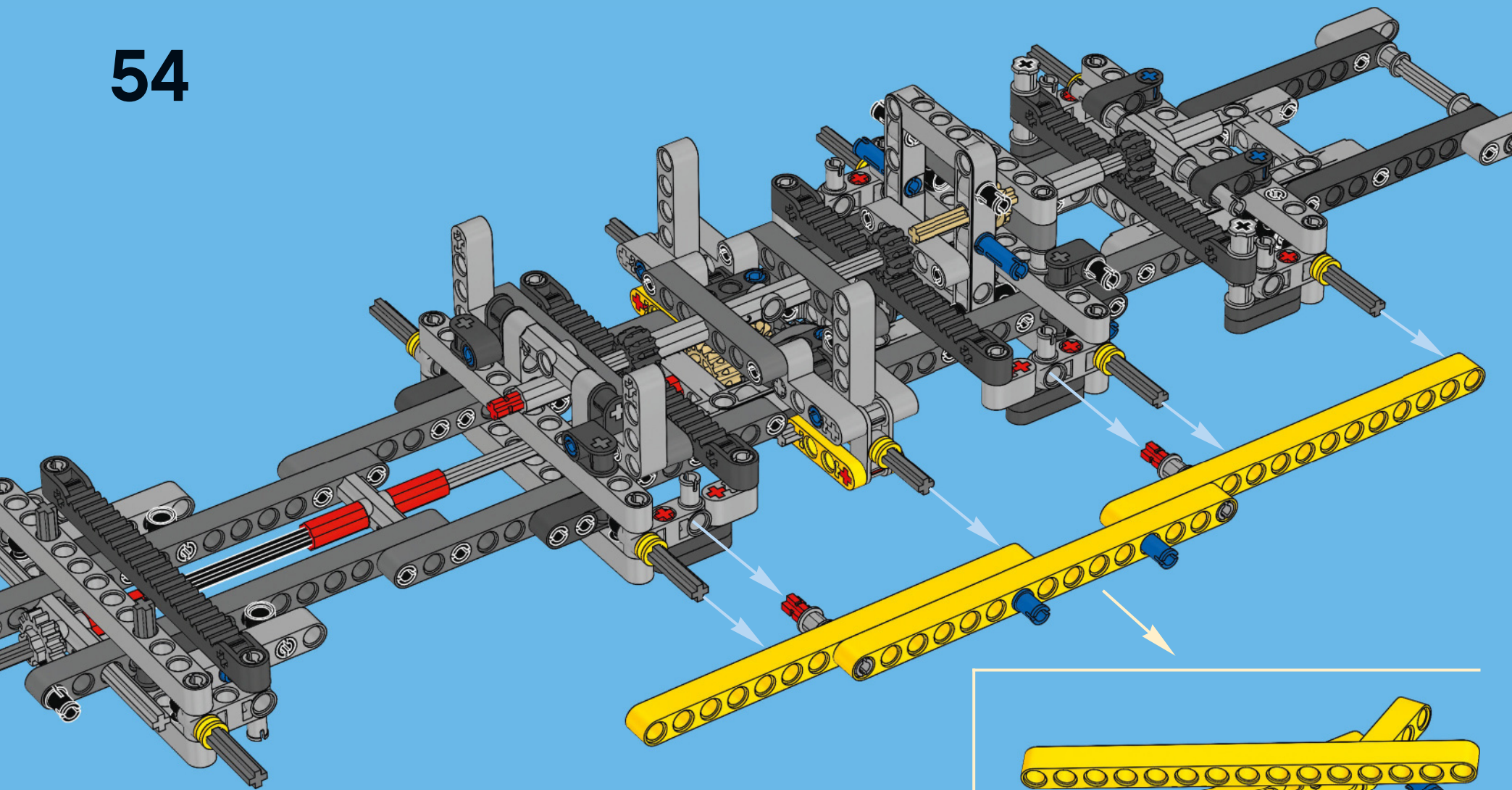

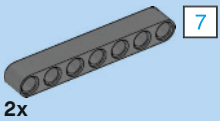

55

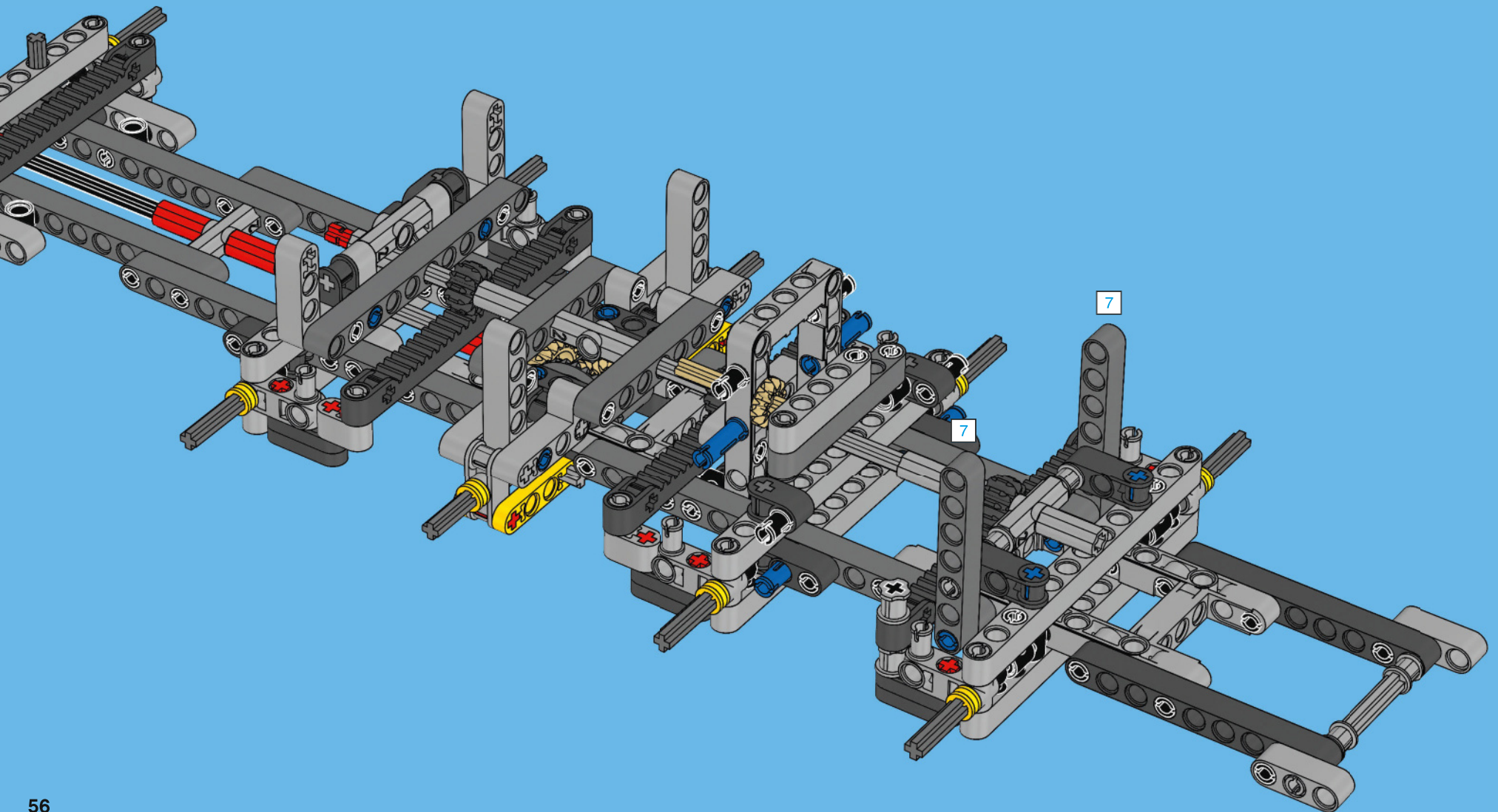



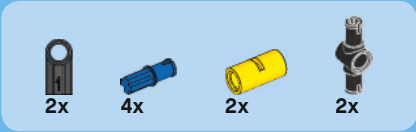

# 56

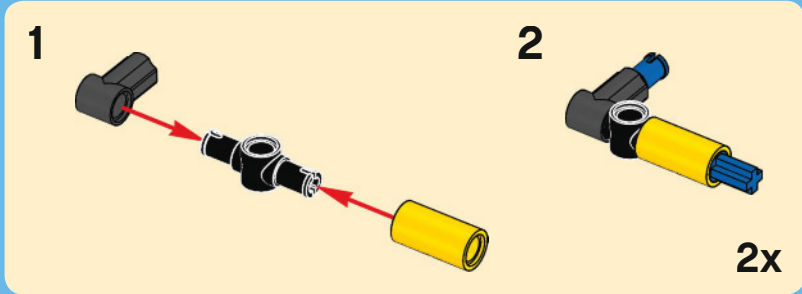
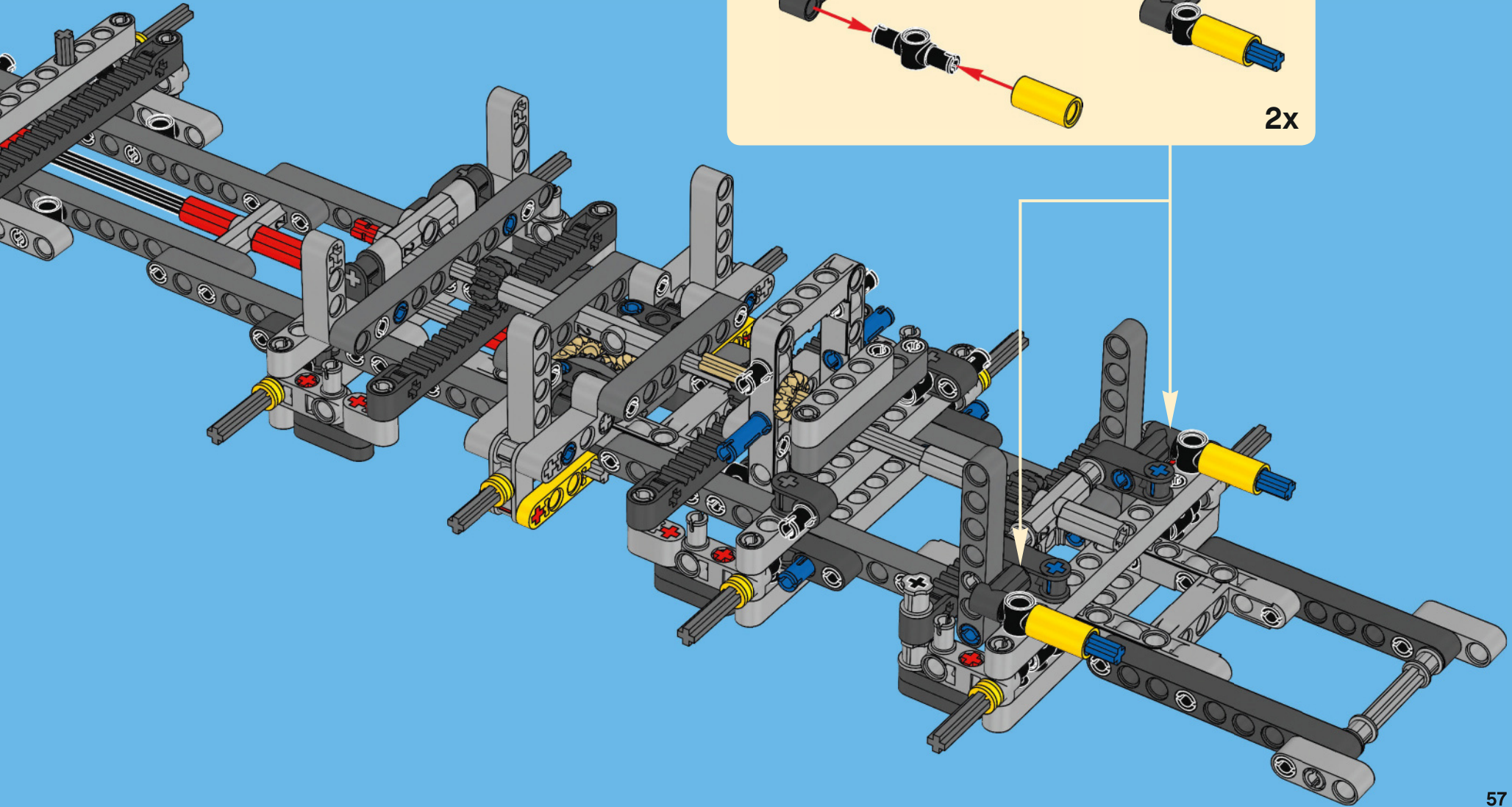





2x

57

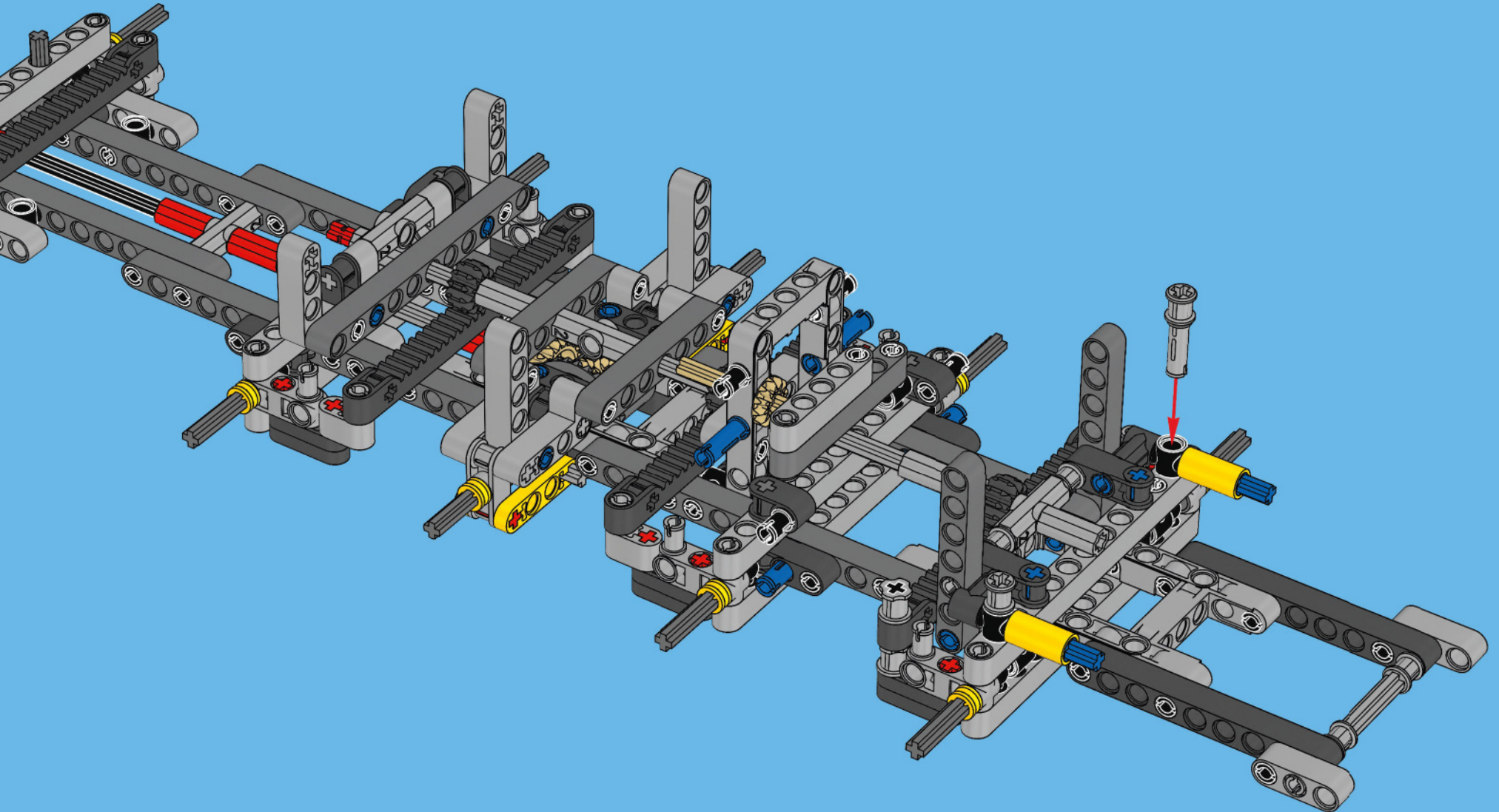

58



# 58

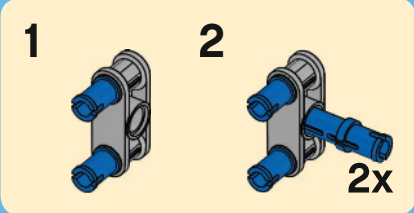
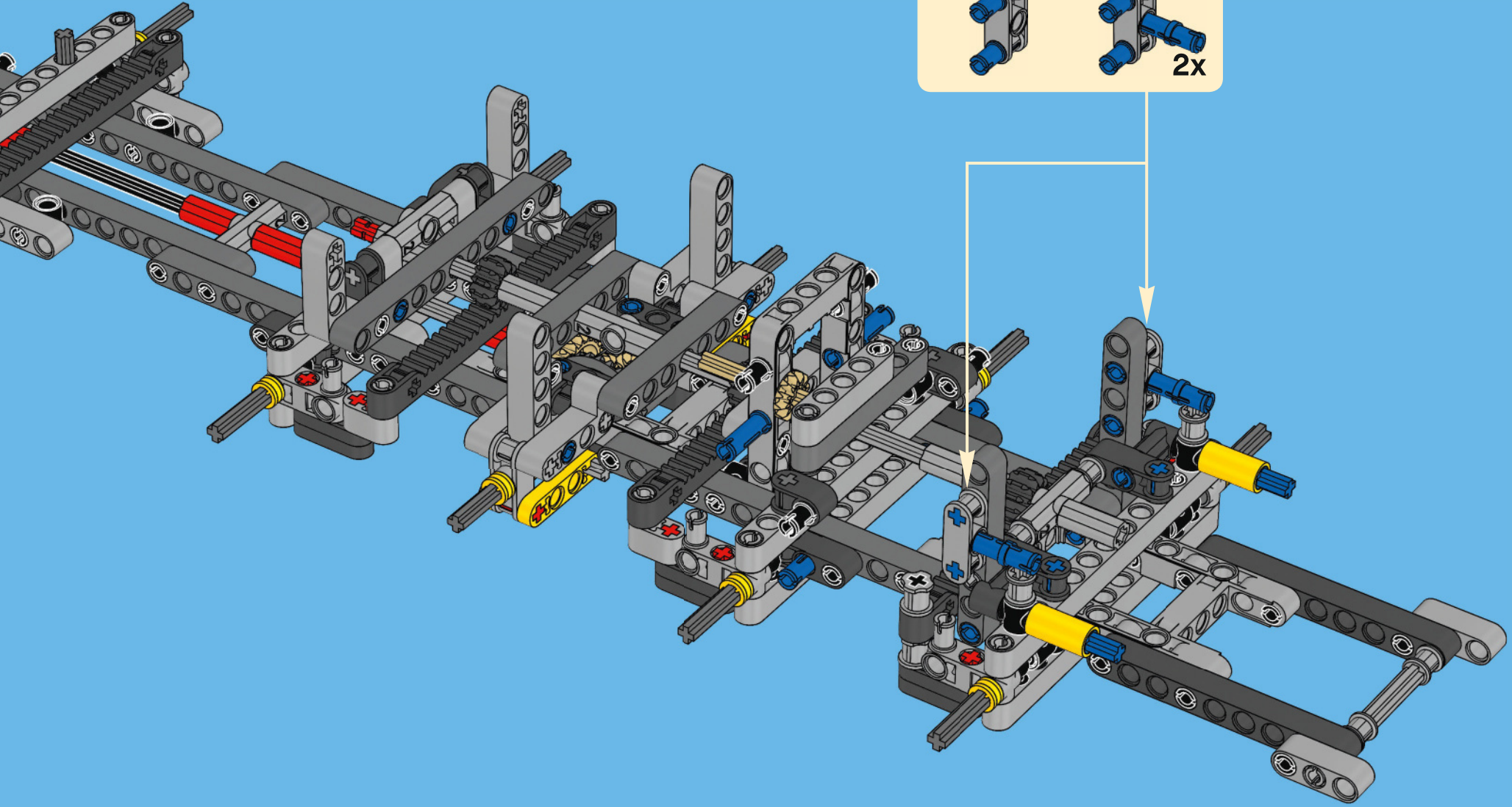



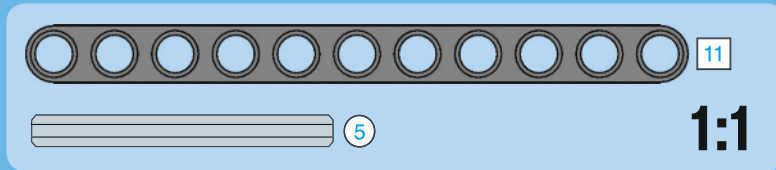
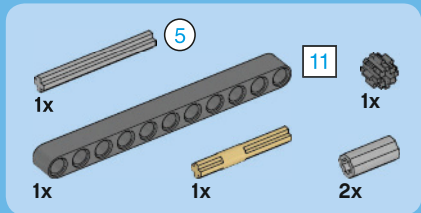

59

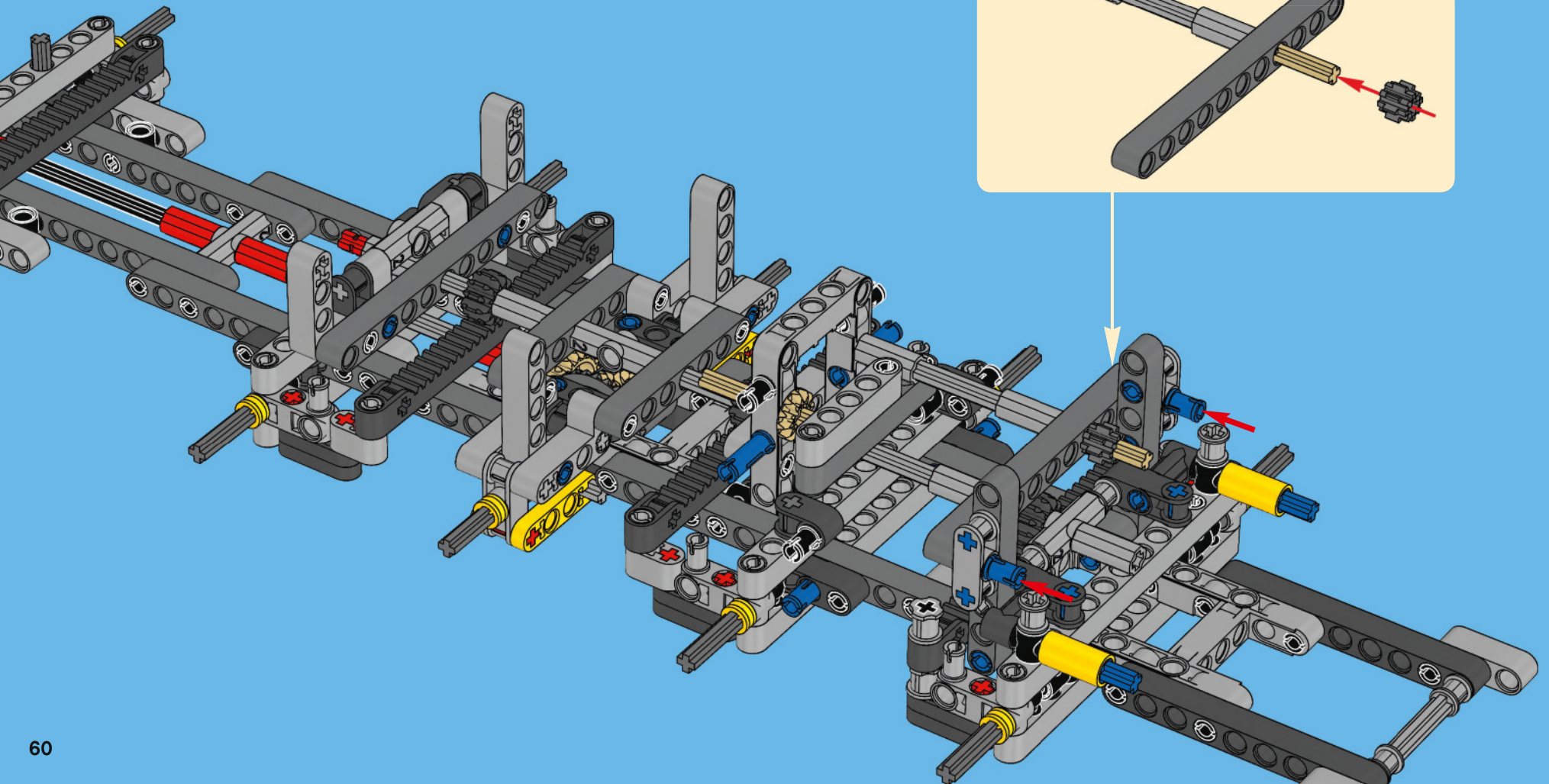
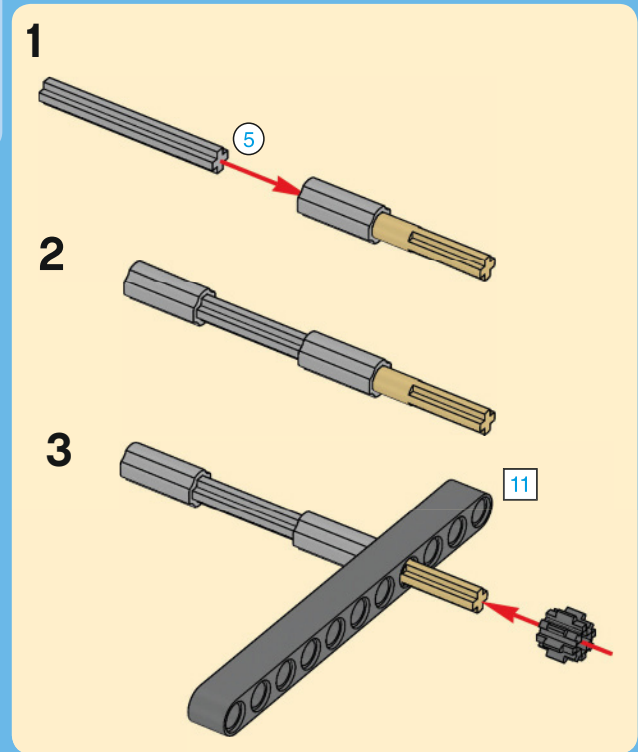



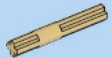

1x



1x

# 60

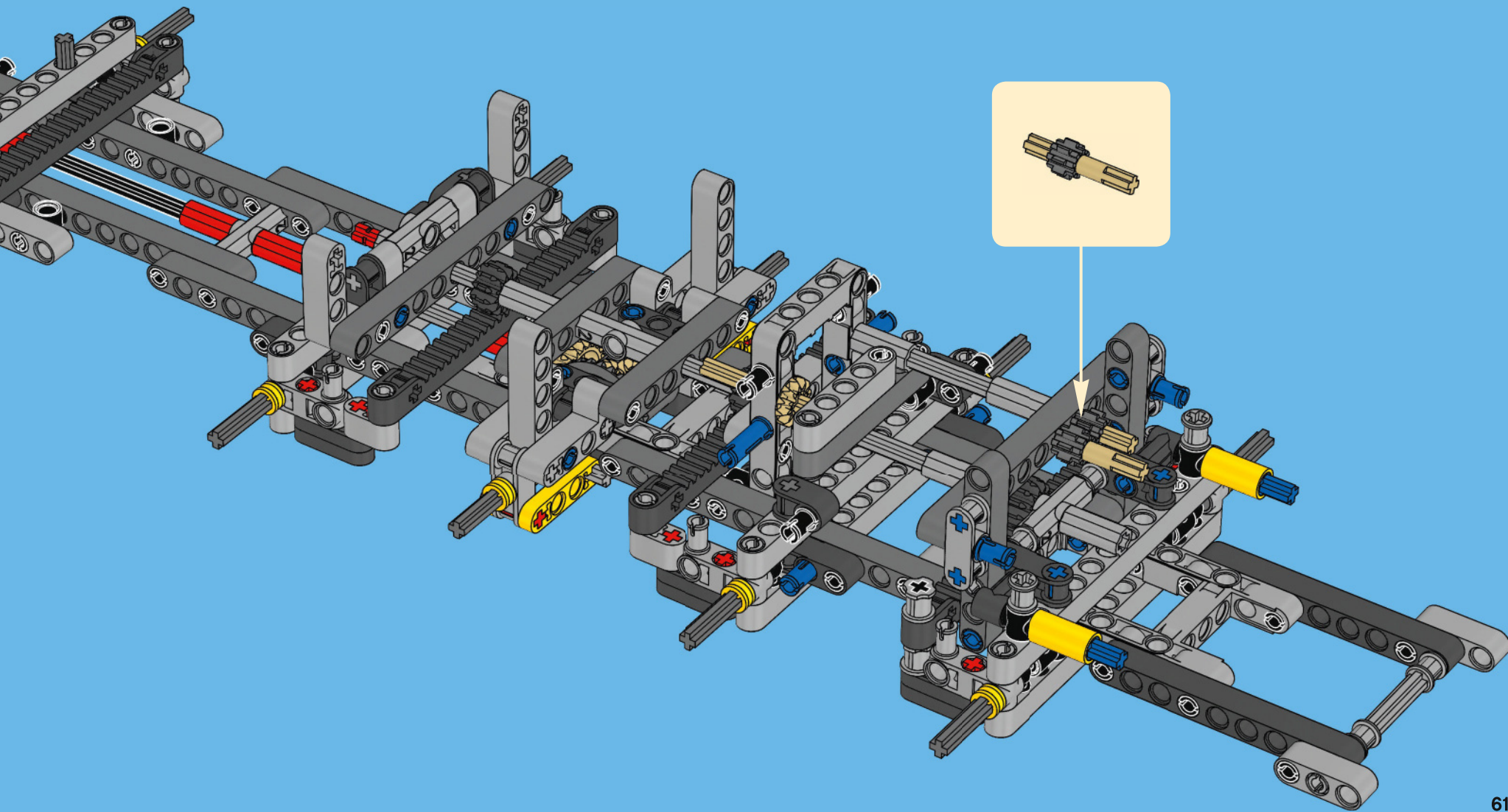

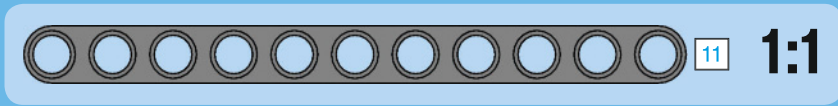
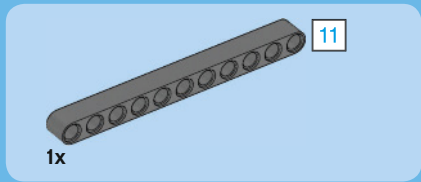

61

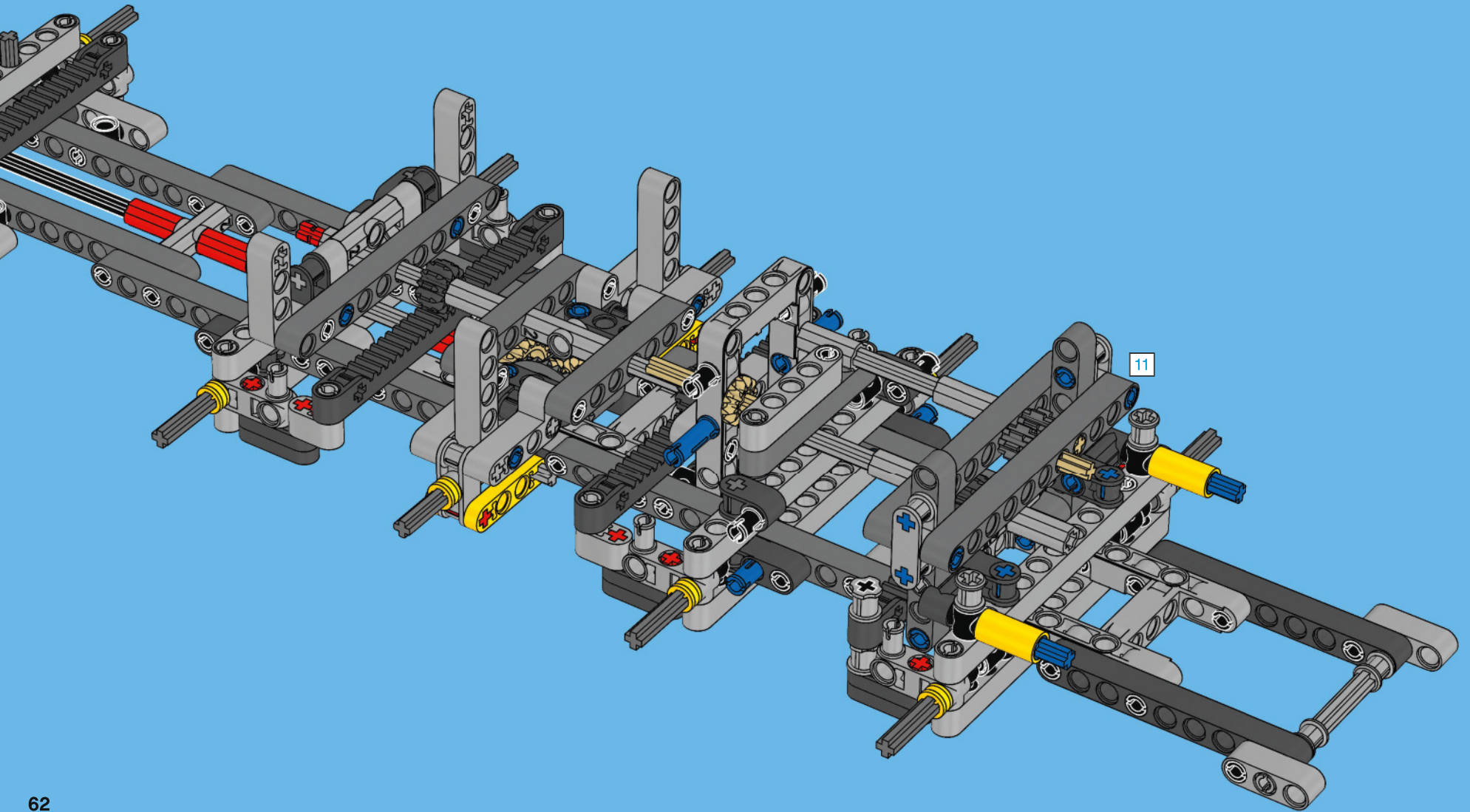



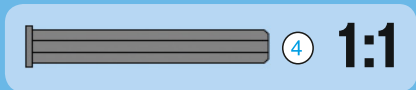
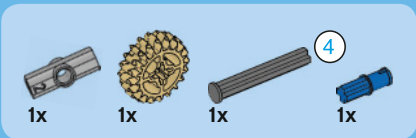

62

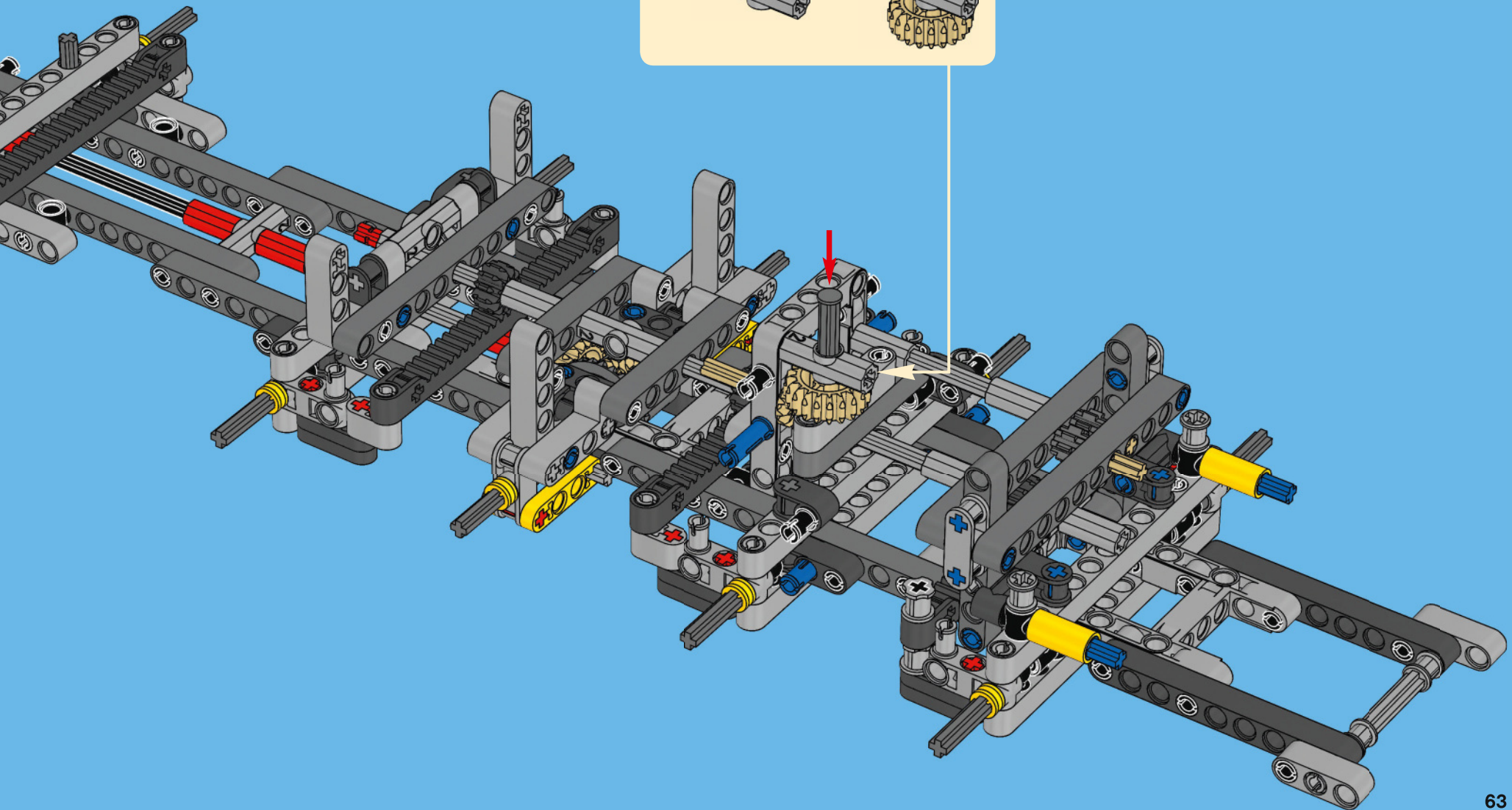
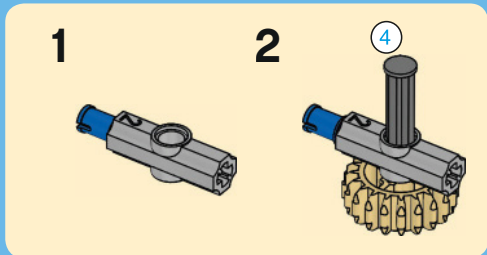



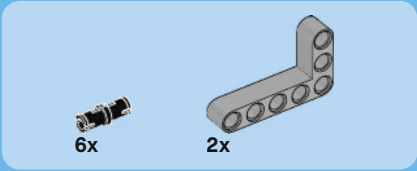

63

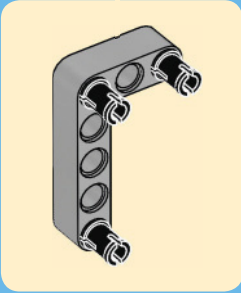
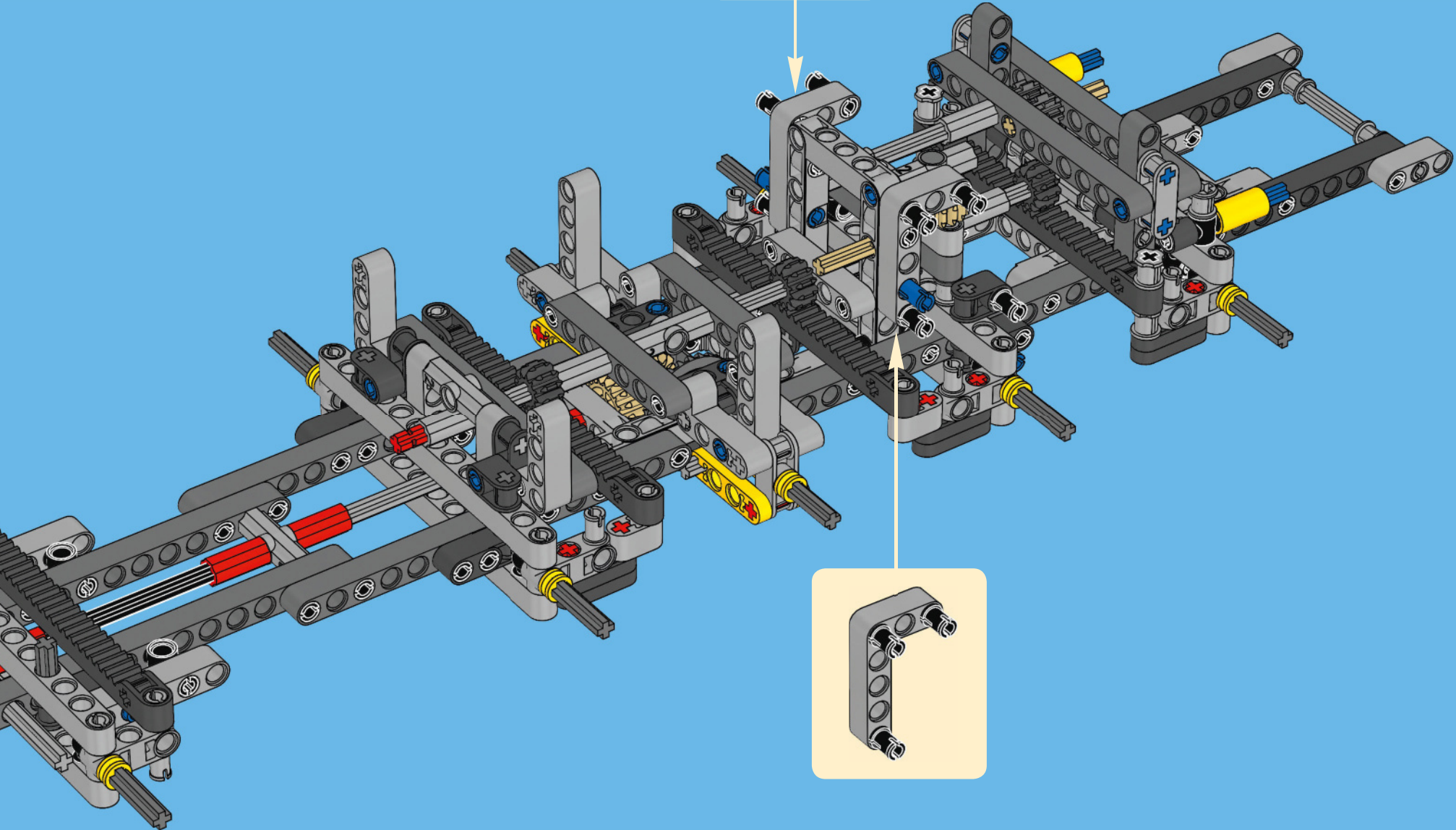
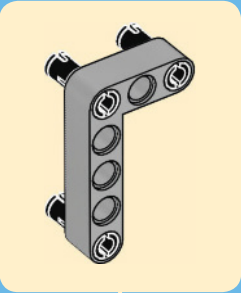



2x



2x

# 64

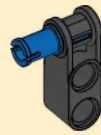

2x

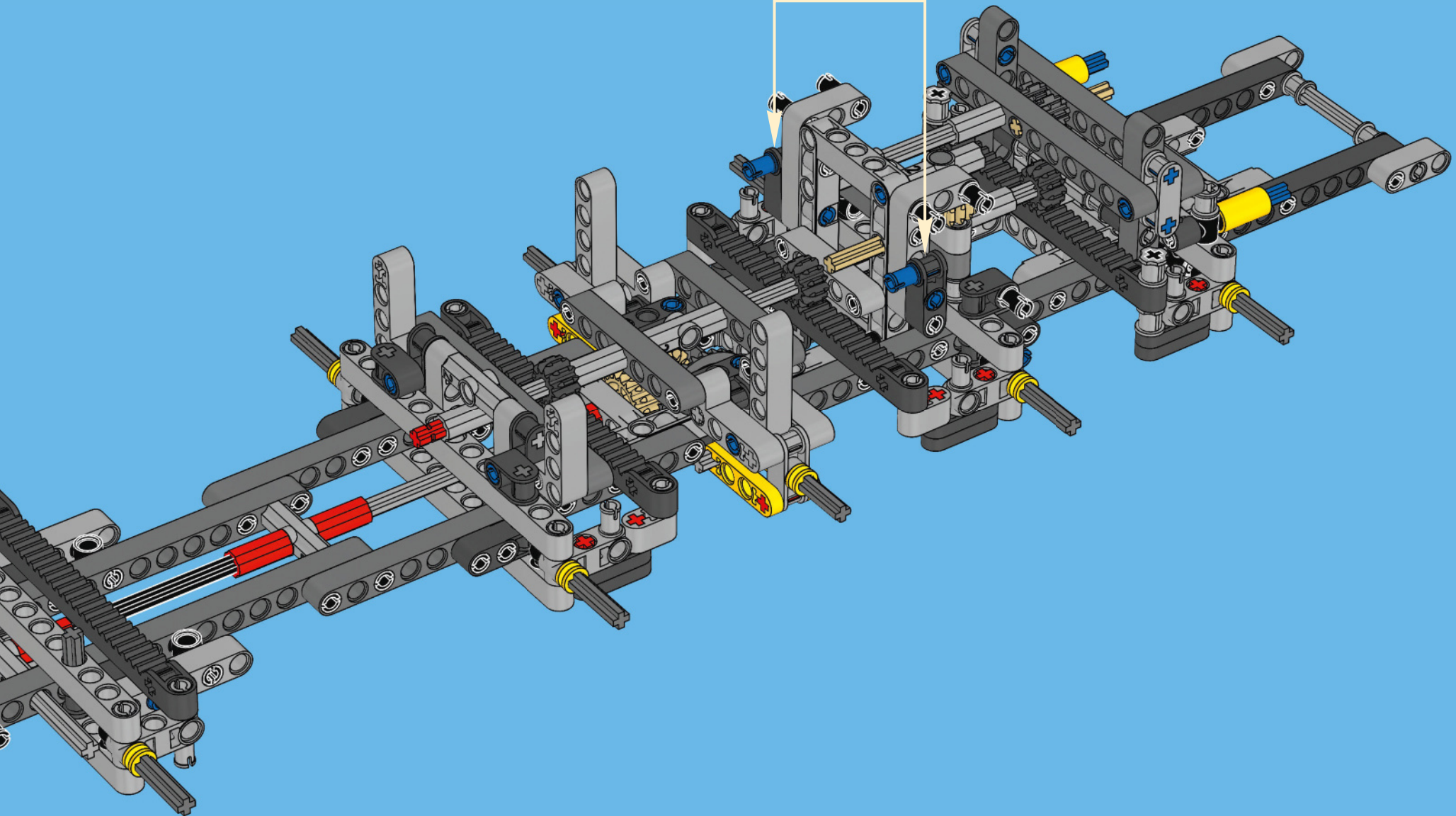



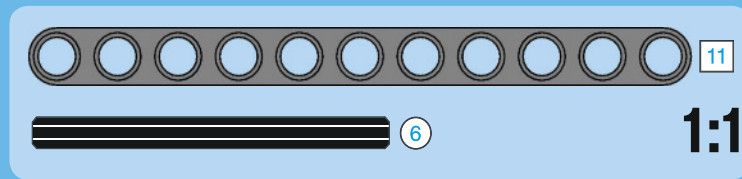
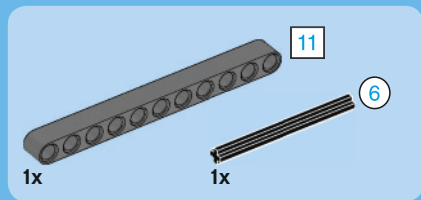

65

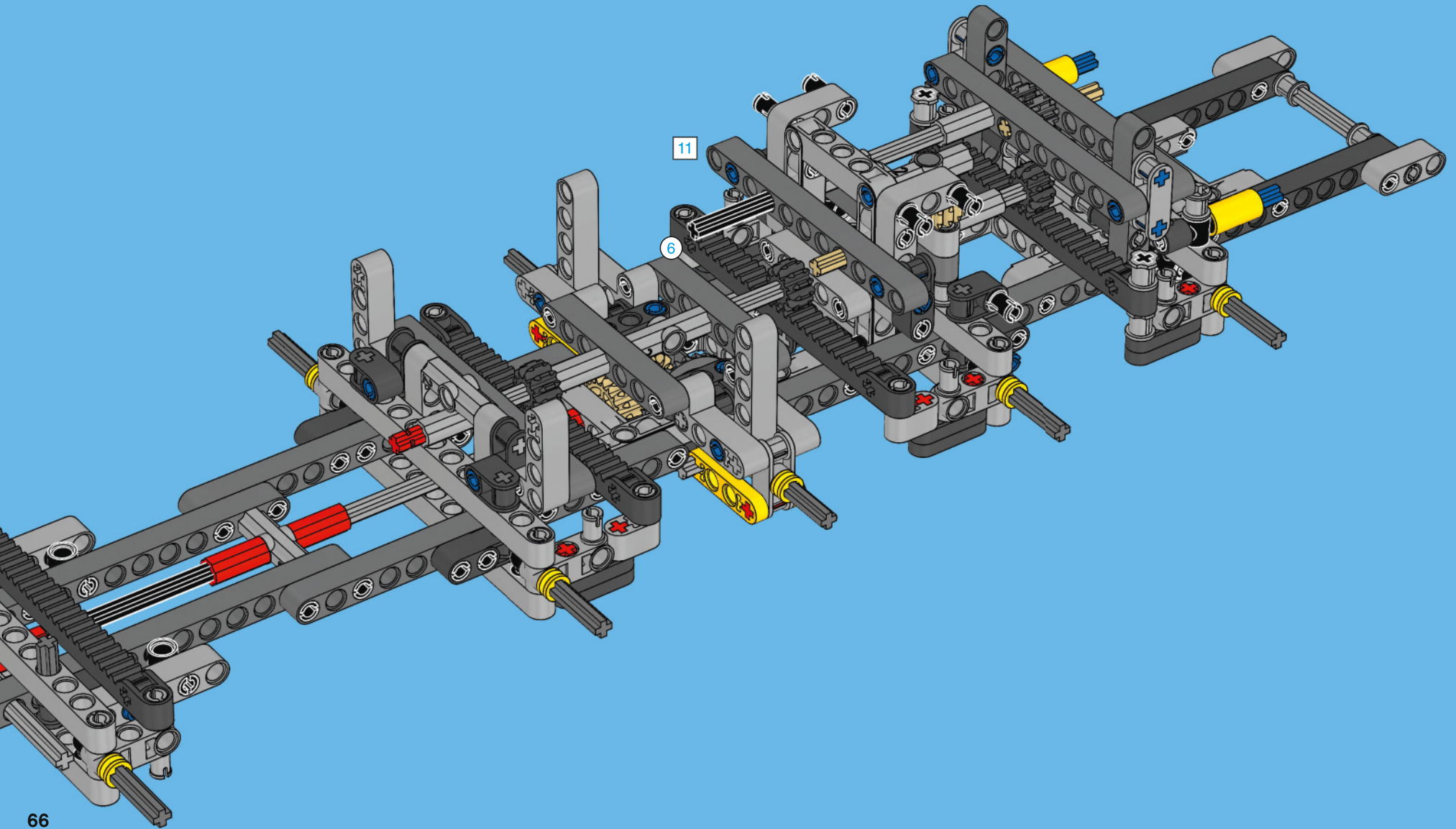

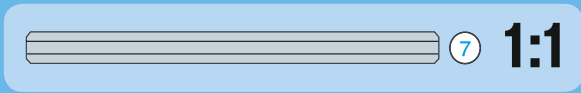
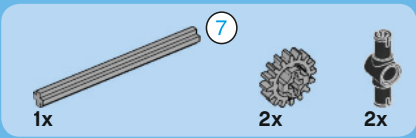

66

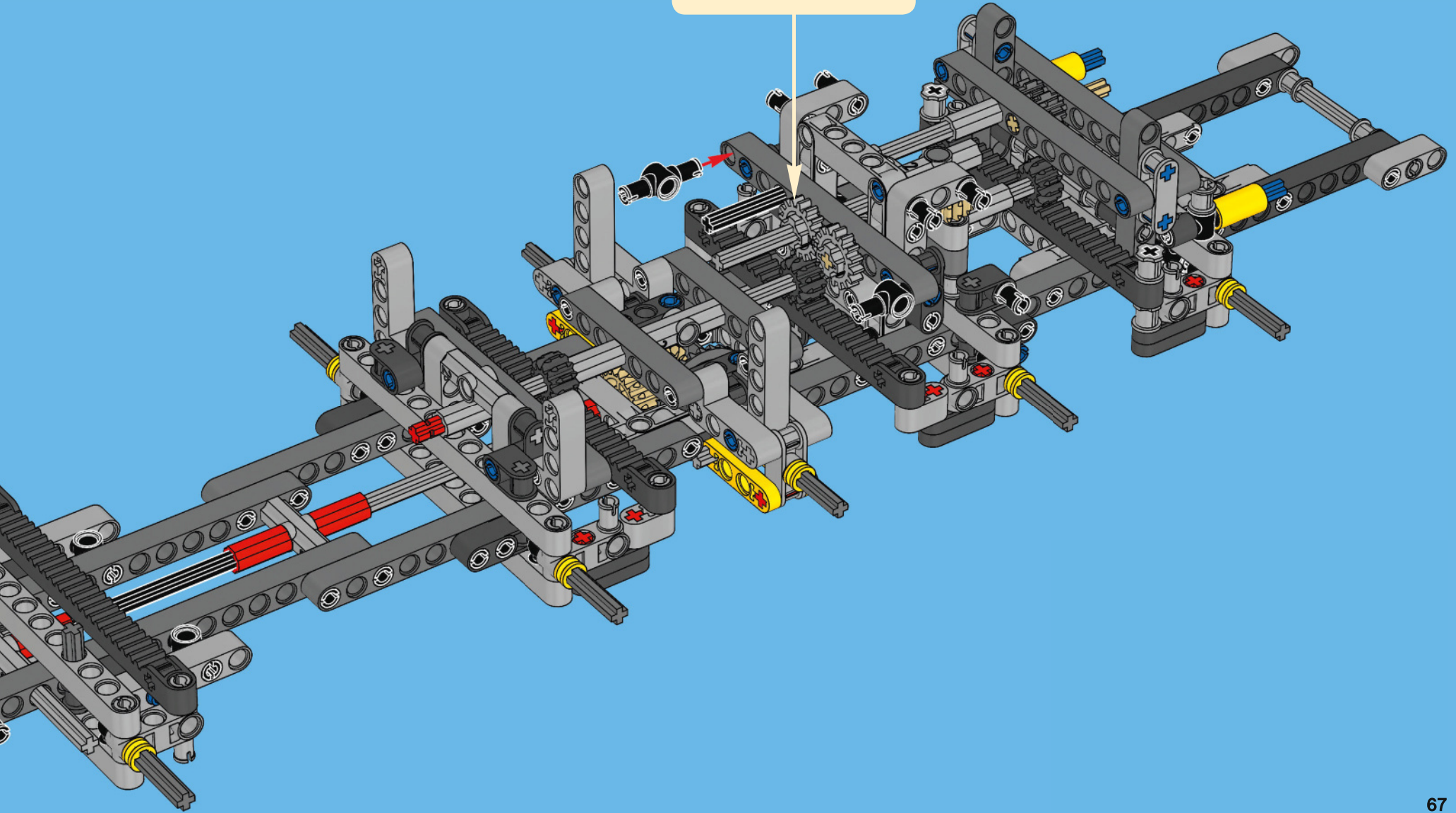
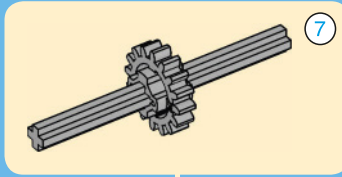



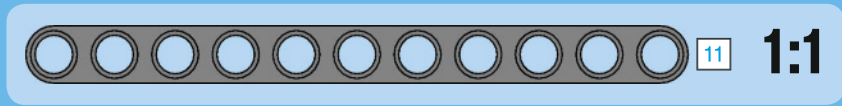
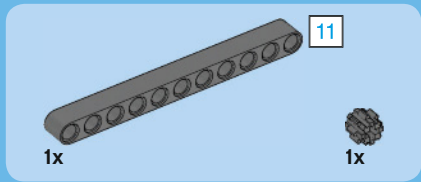

67

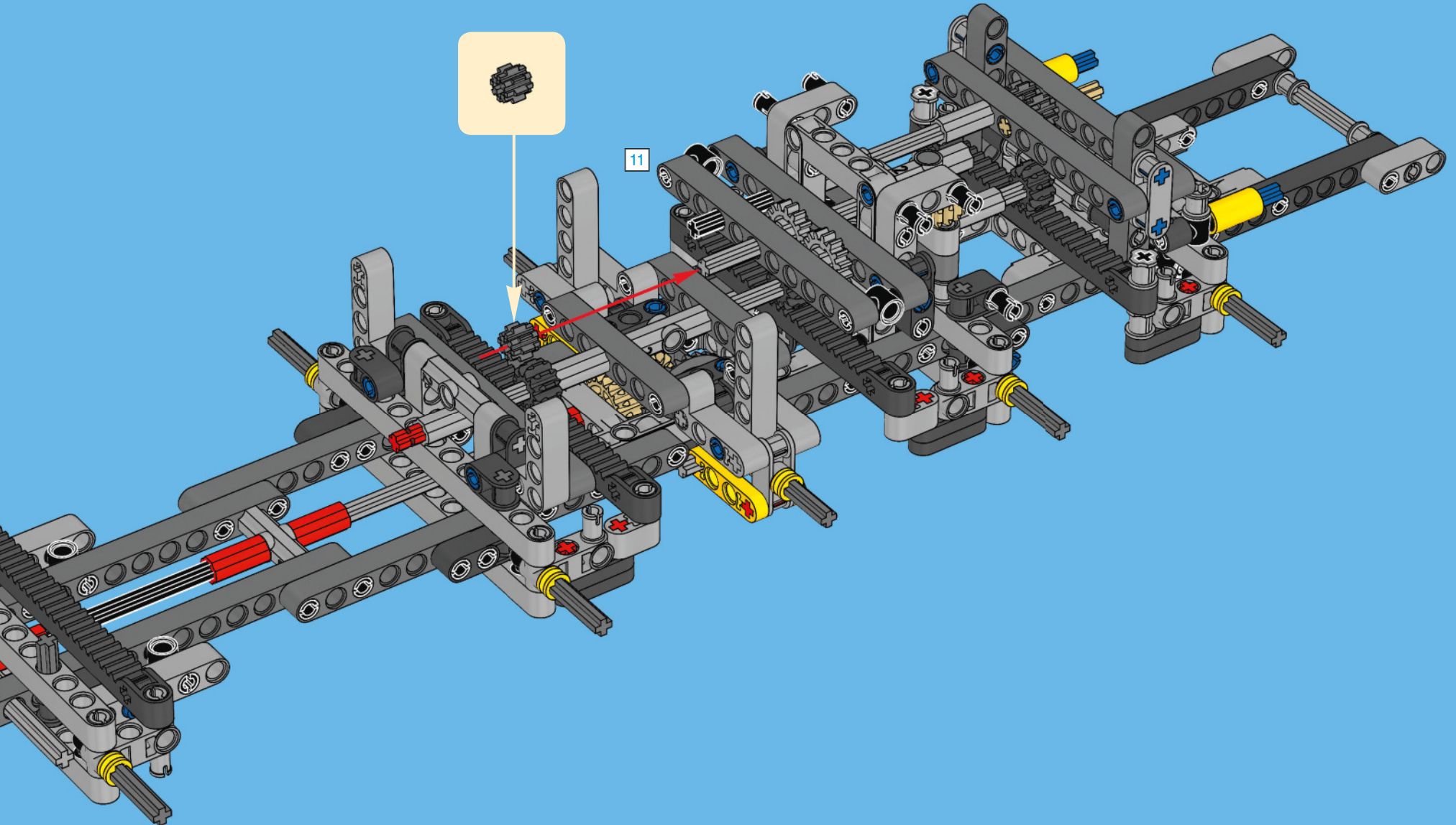

2x 1x 2x

68

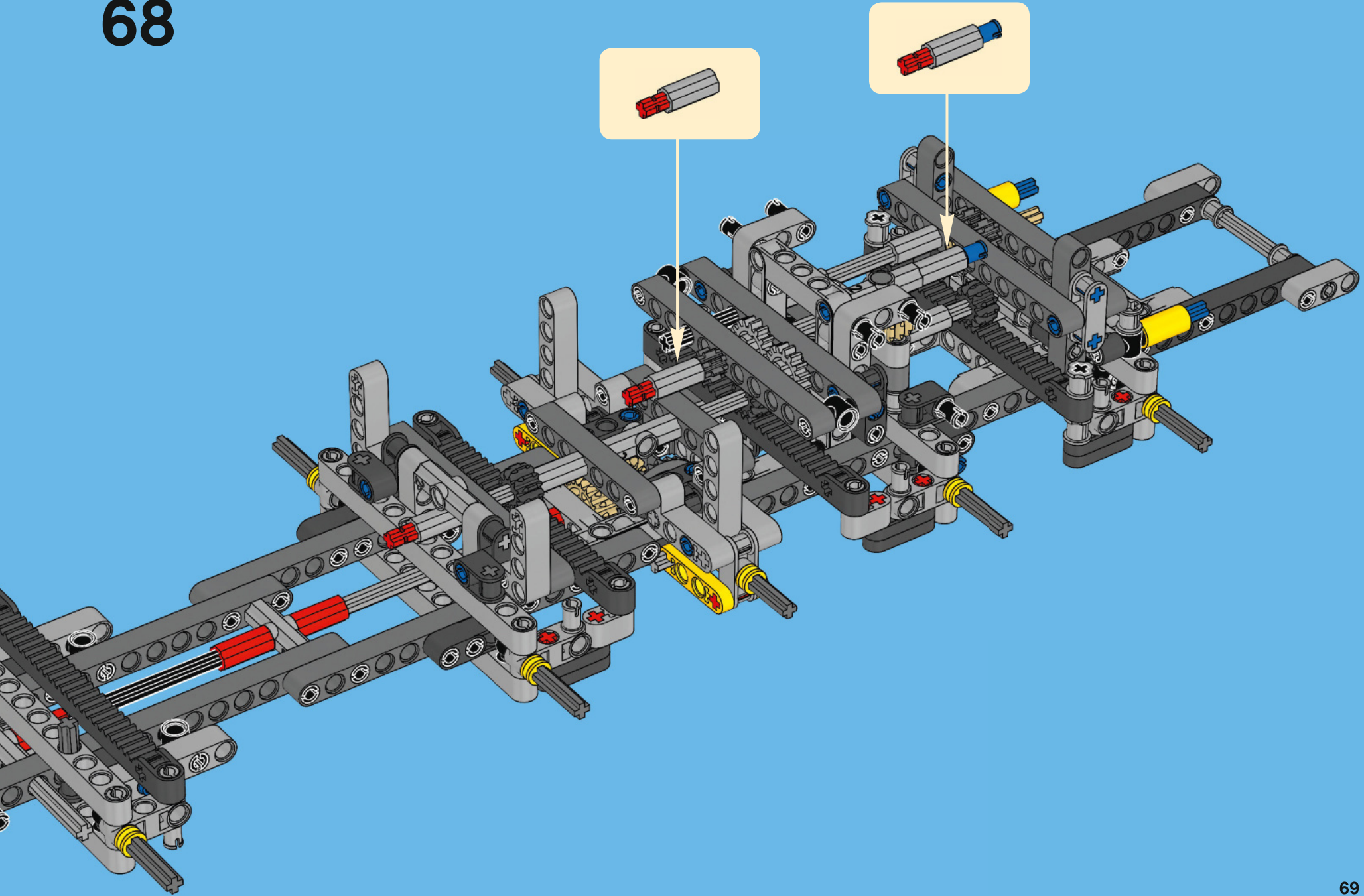



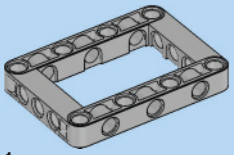

1x

69

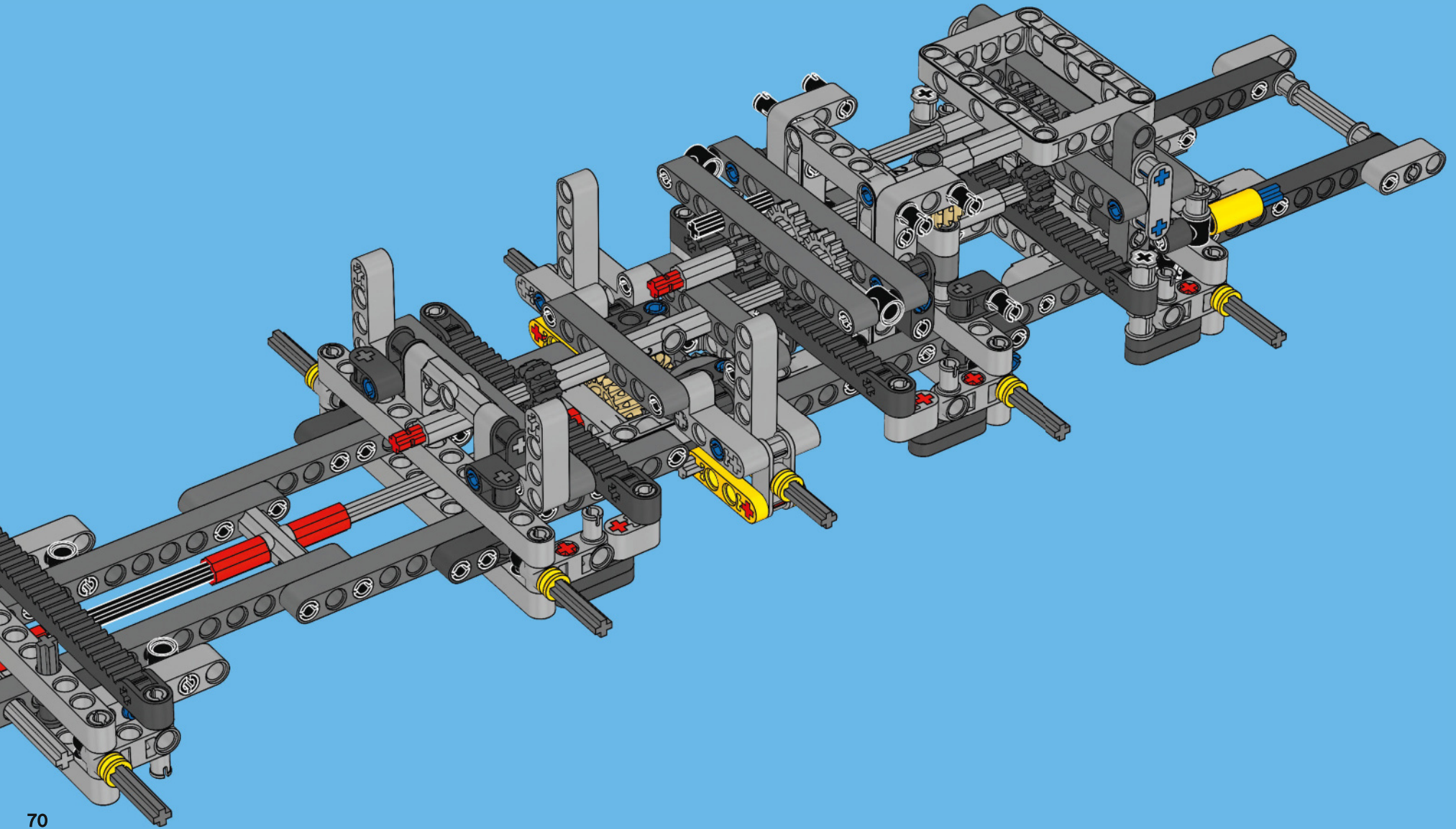



2x

# 70

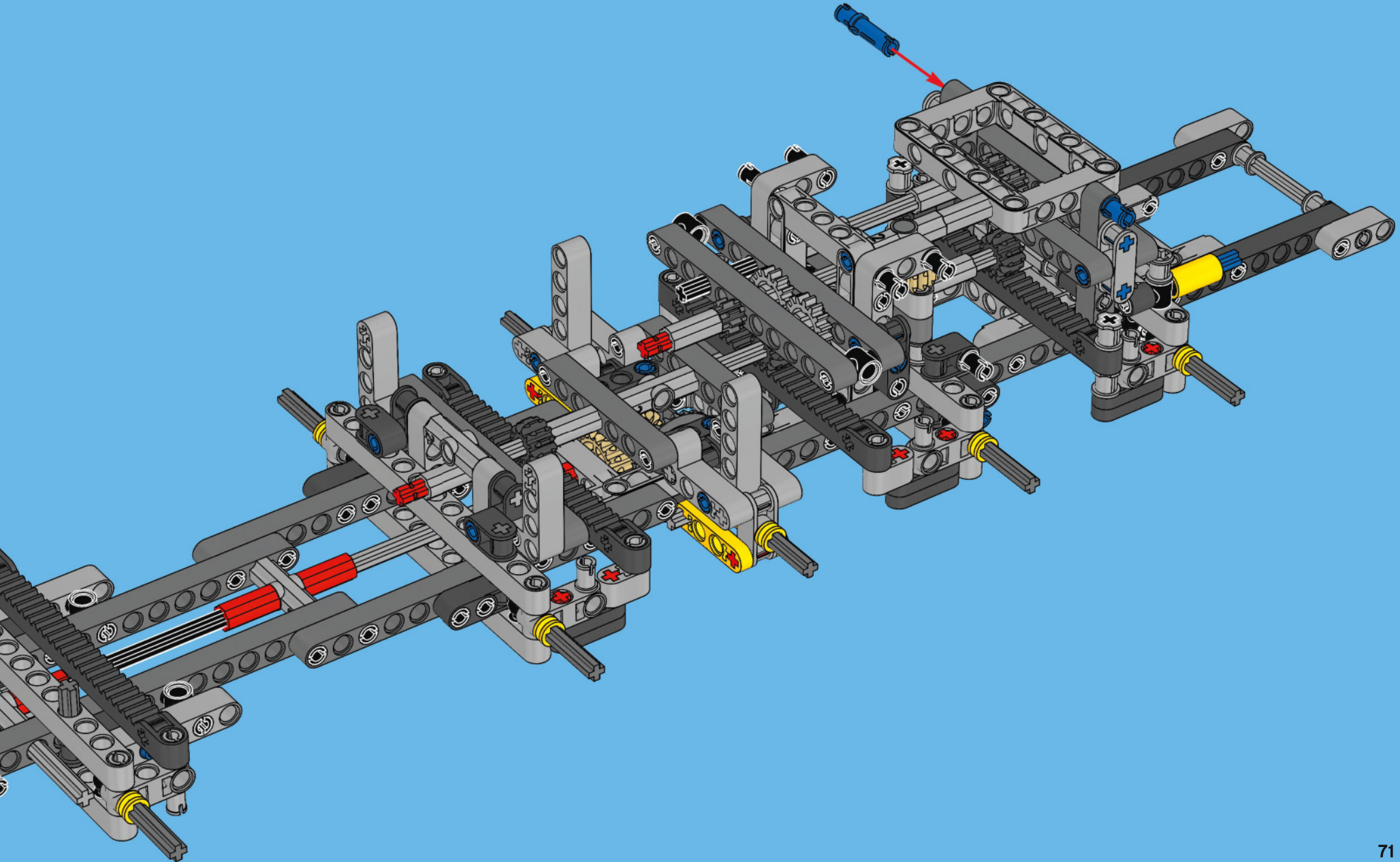





2x



2x

# 71

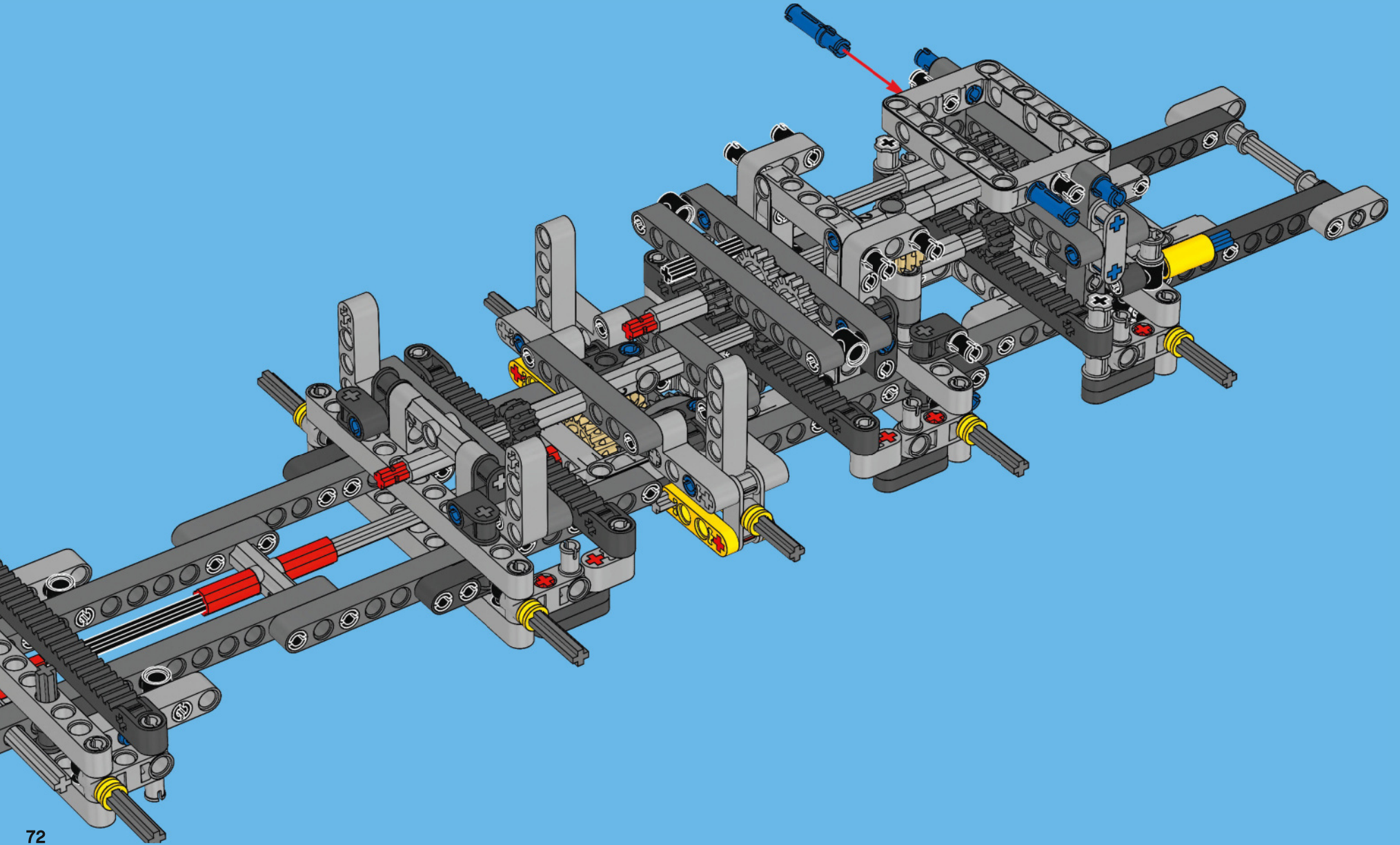



2x

# 72

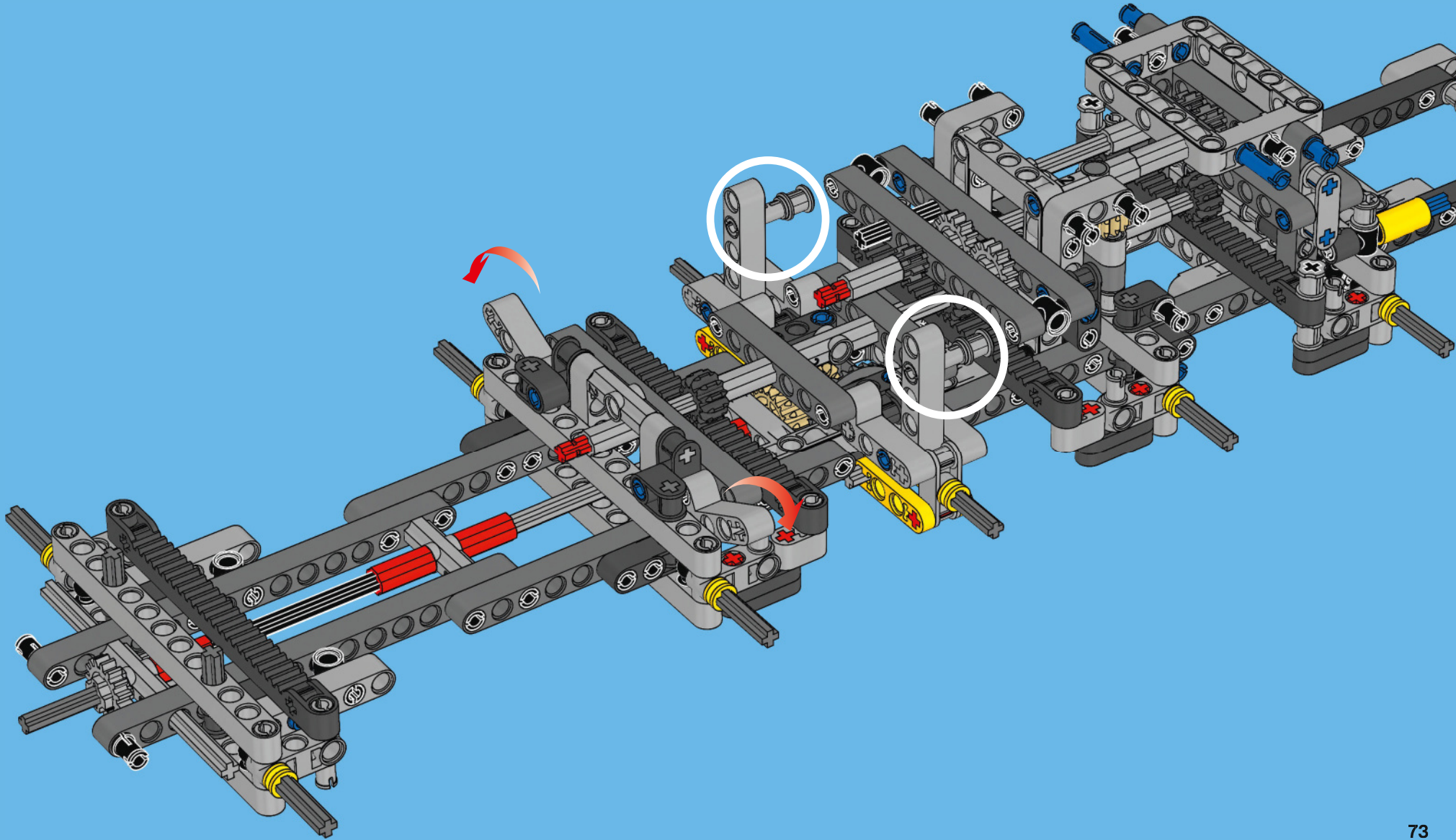



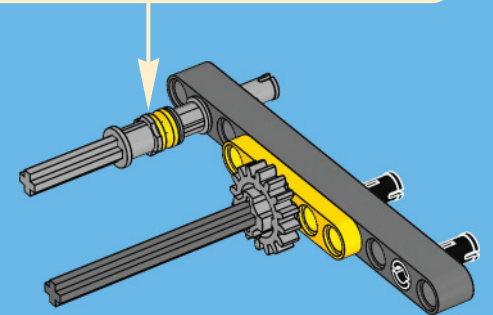
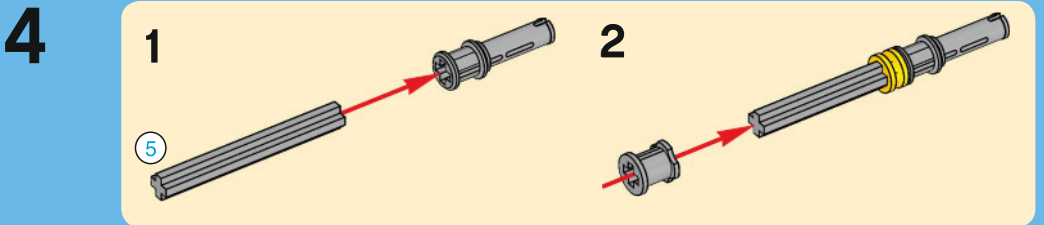
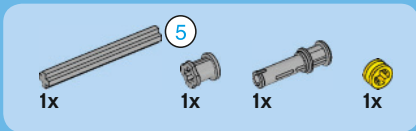
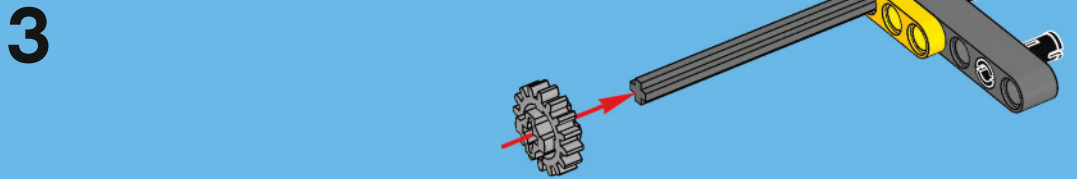
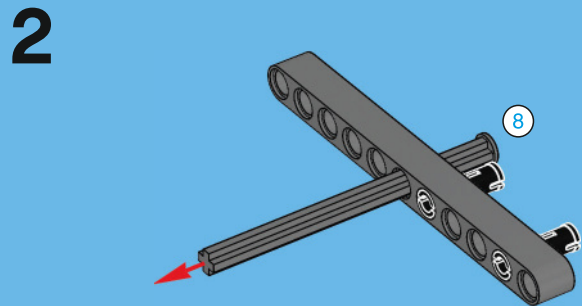
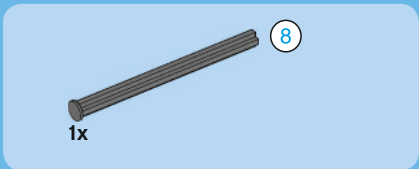
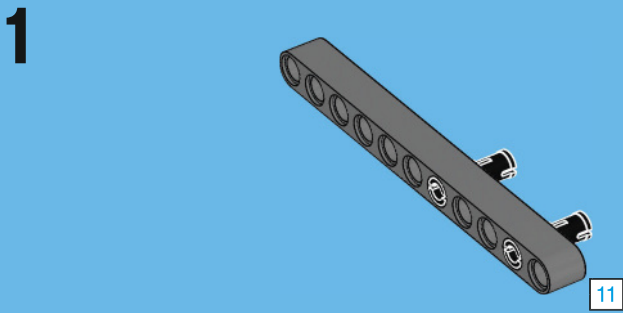
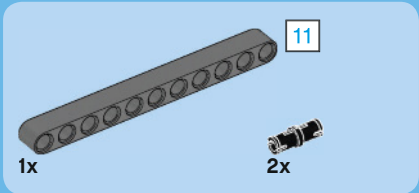
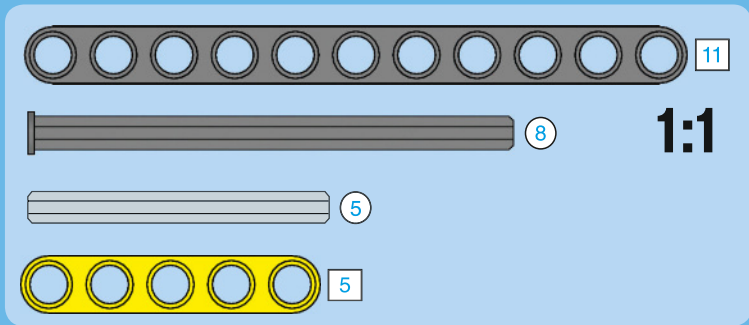
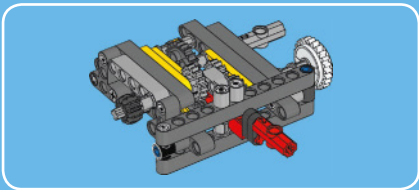

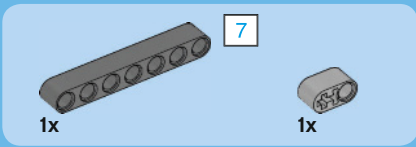

5

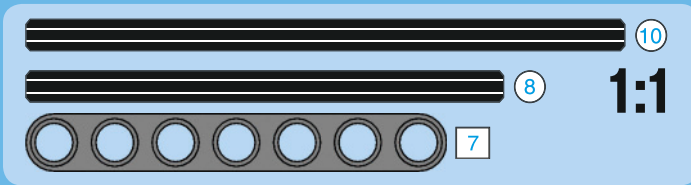
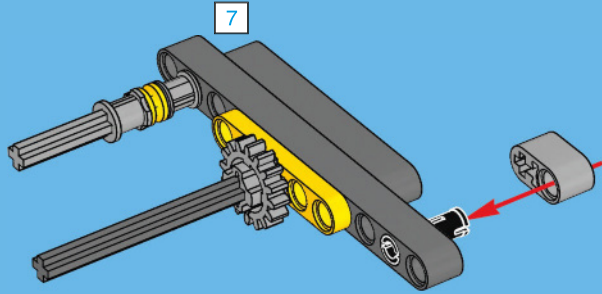

7

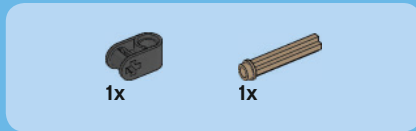
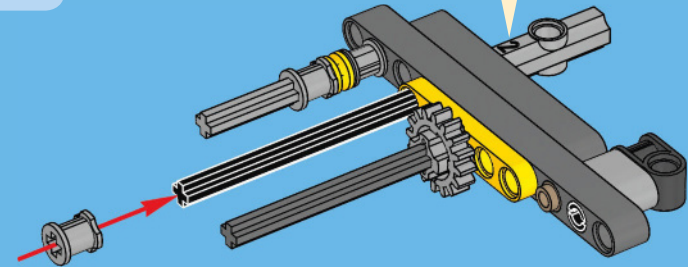
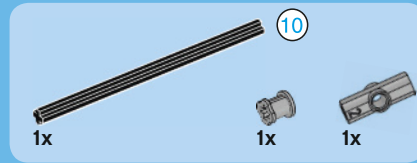

6

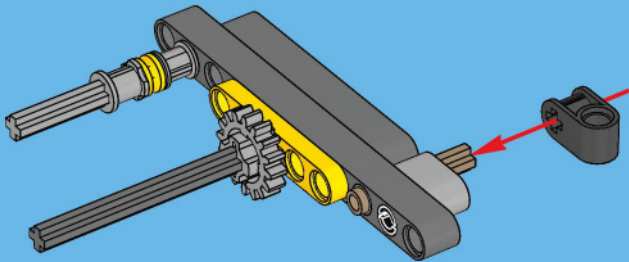

8

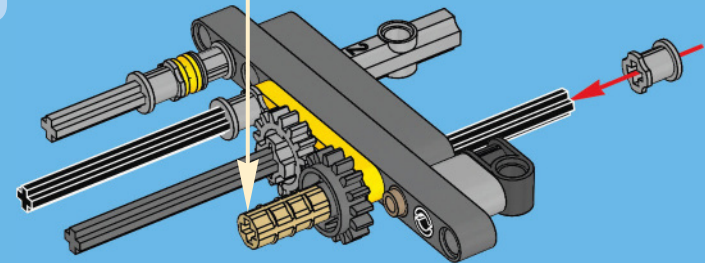
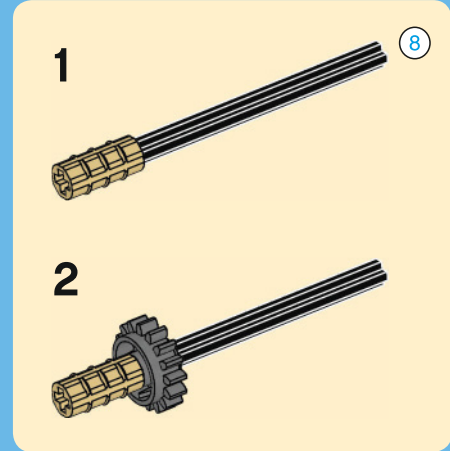
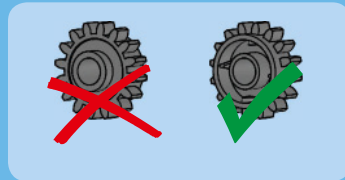
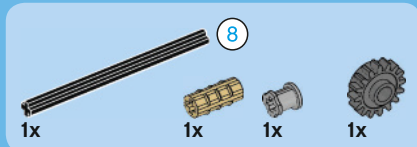





9

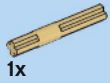
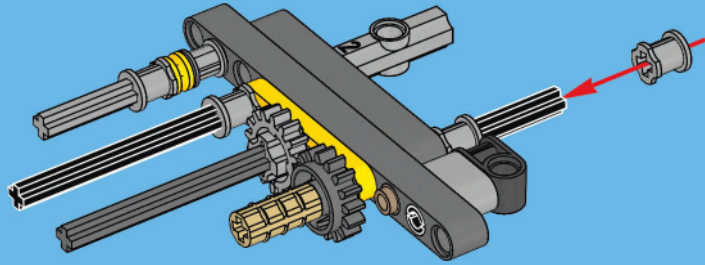

10

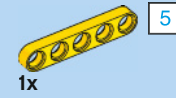
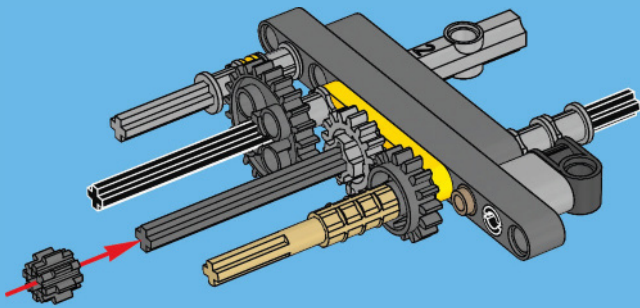

5

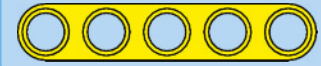

1:1

11

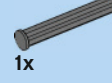
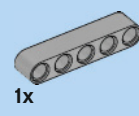
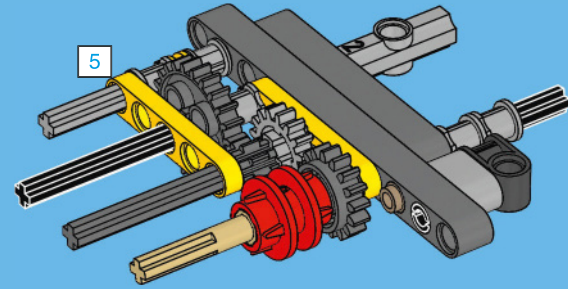

5

4

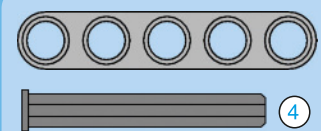

1:1

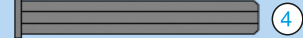

12

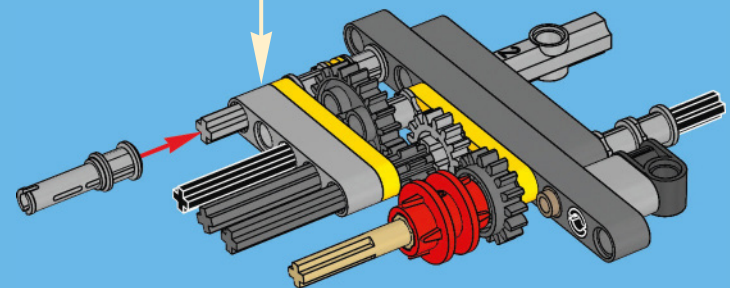
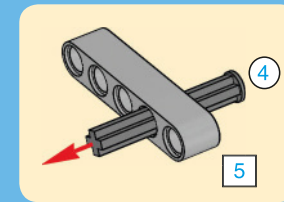

2x

13

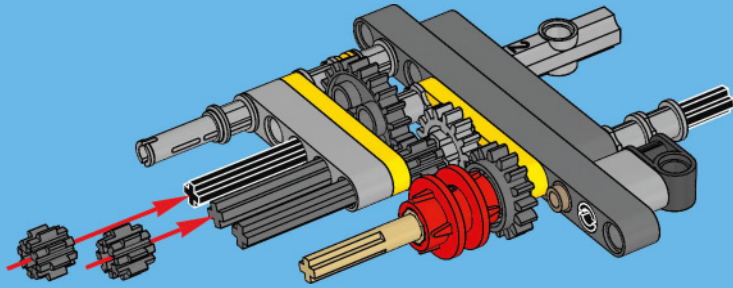

1x

1x

14

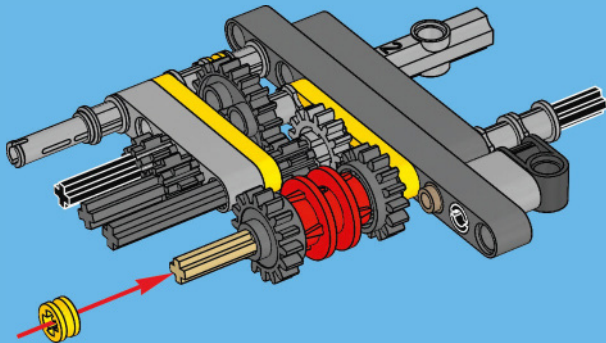
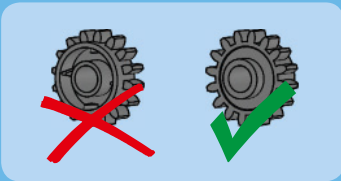

1:1

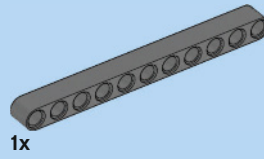

1x

11



1x

15

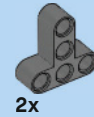
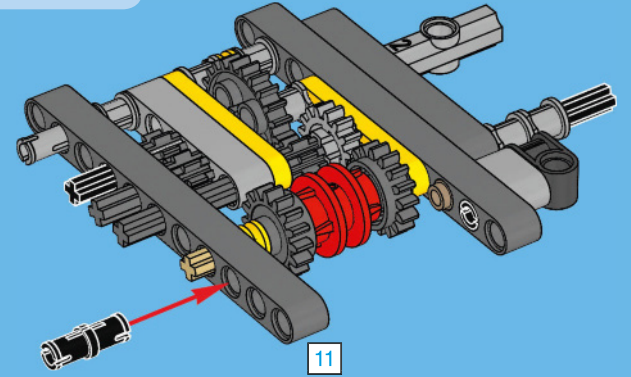

2x



2x

16

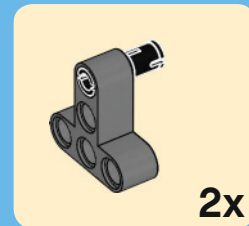

2x

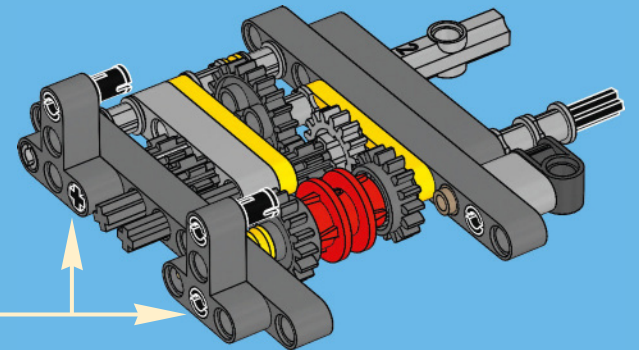

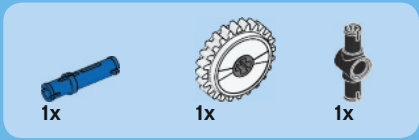

17

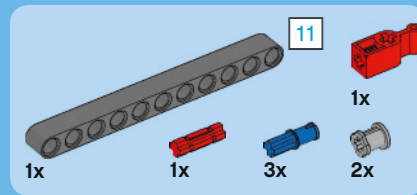
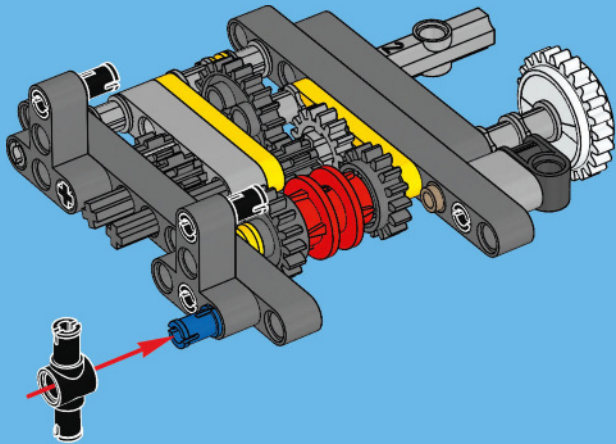

18

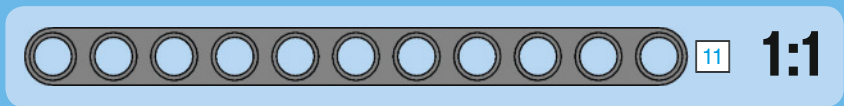
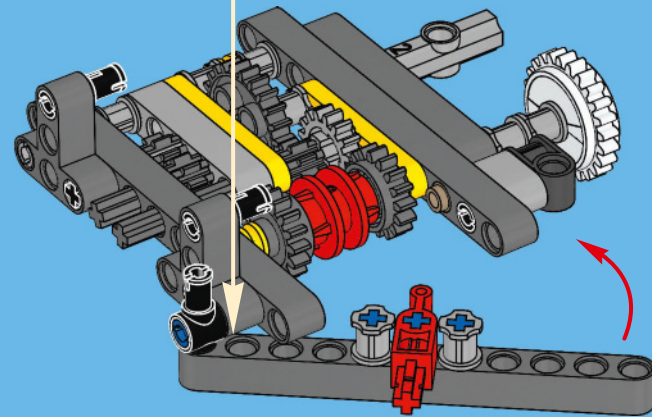
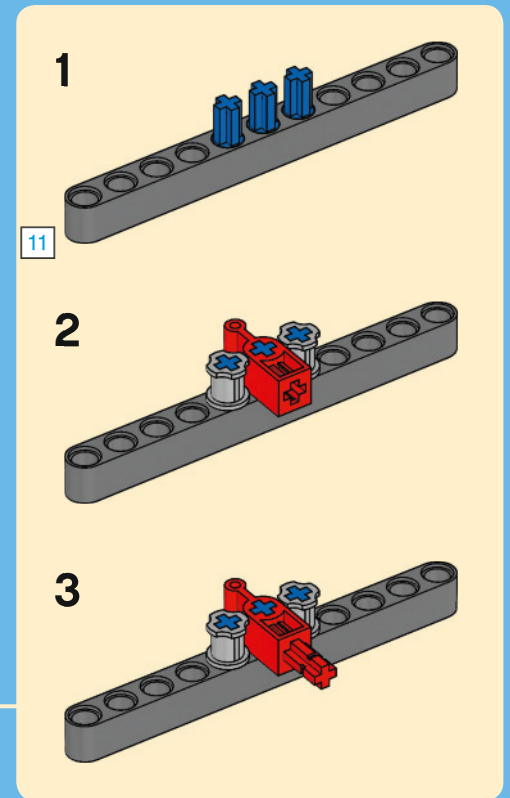





1x

# 19

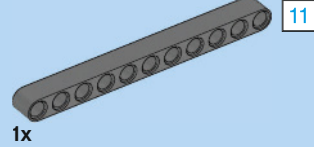
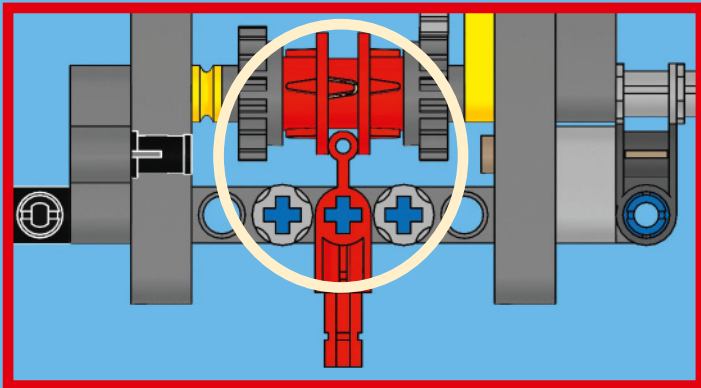
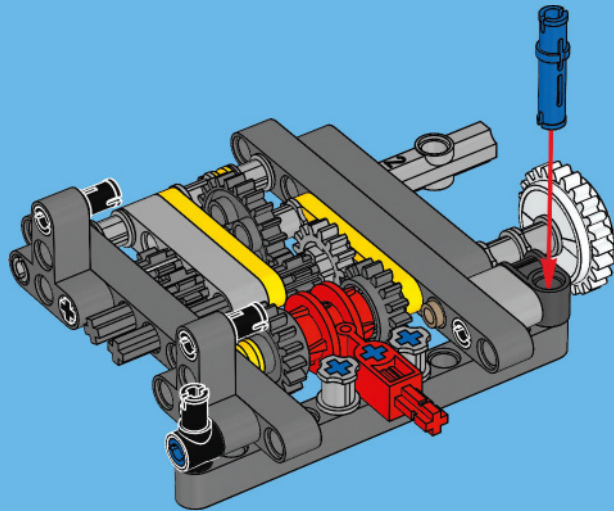

1x

11

# 20

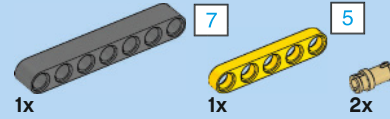
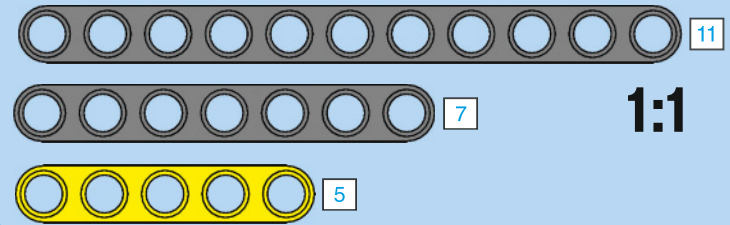
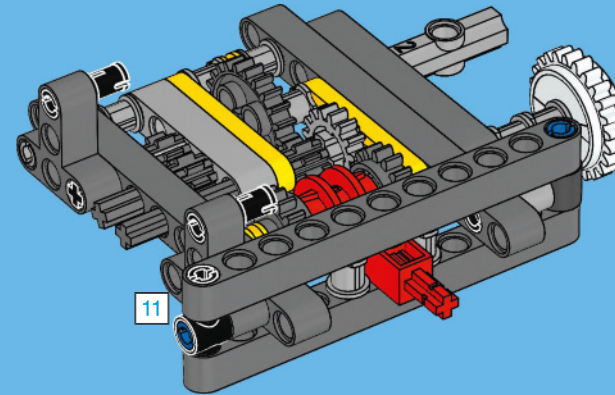

# 21

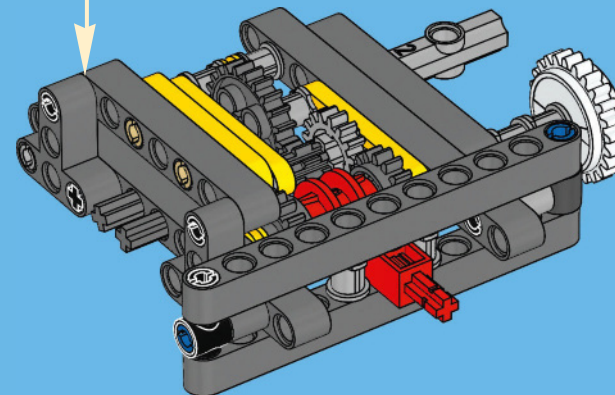
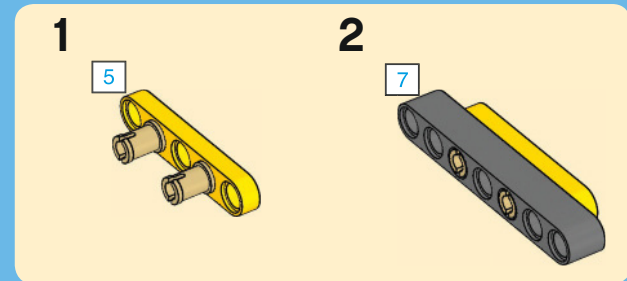

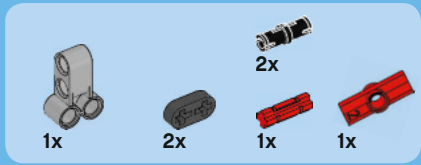

22

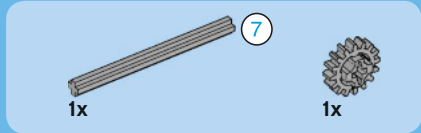
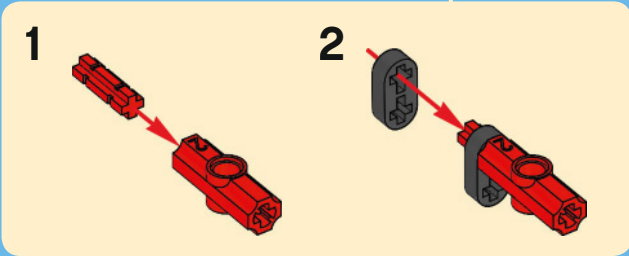
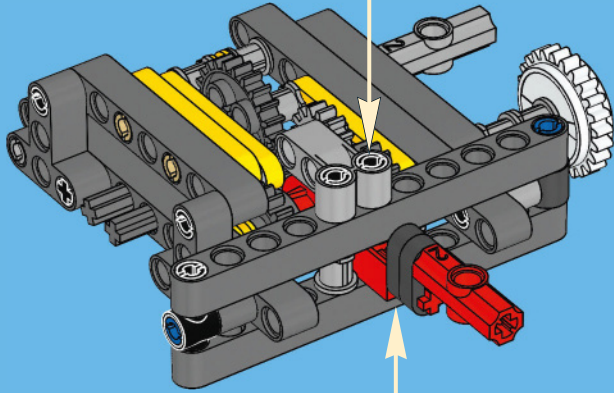
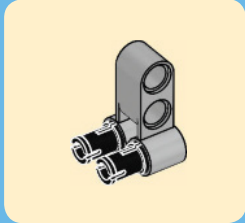

23

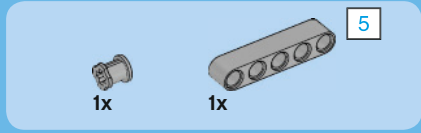
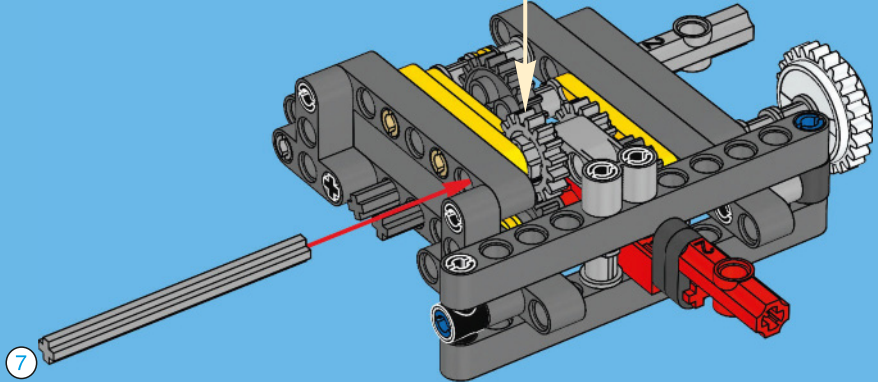
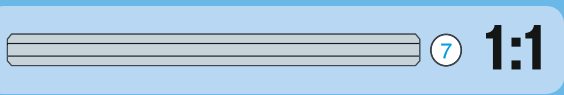

24

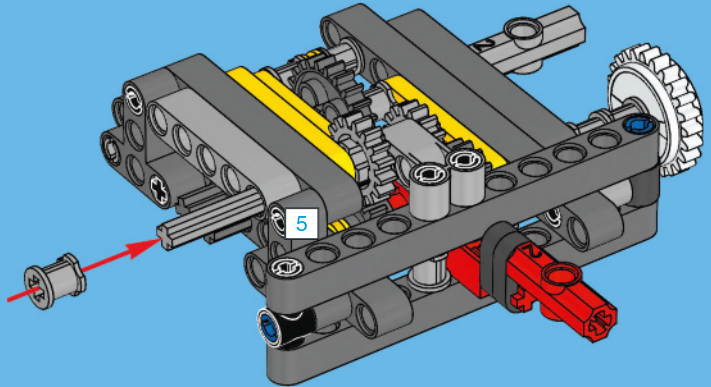
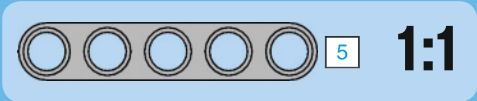



25

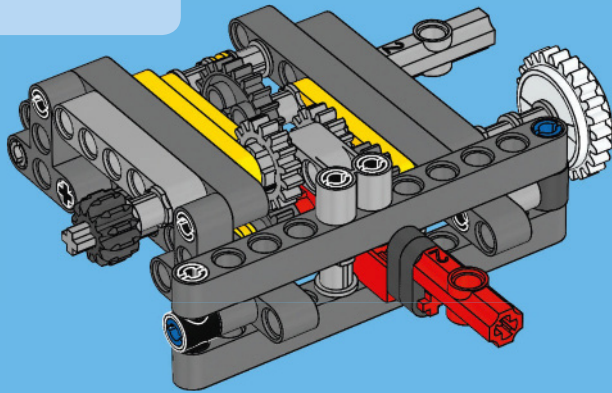

73

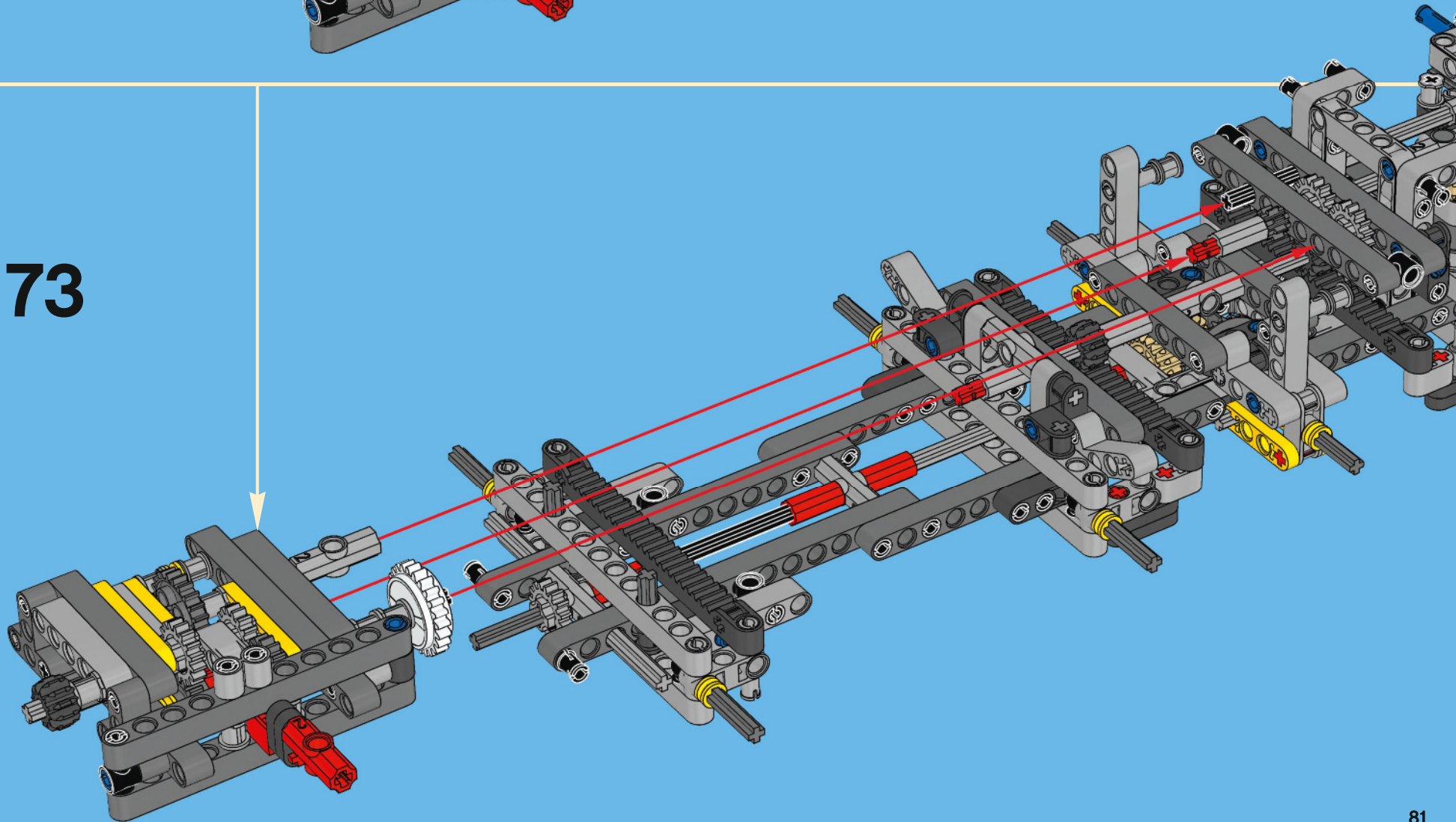





2x

# 74

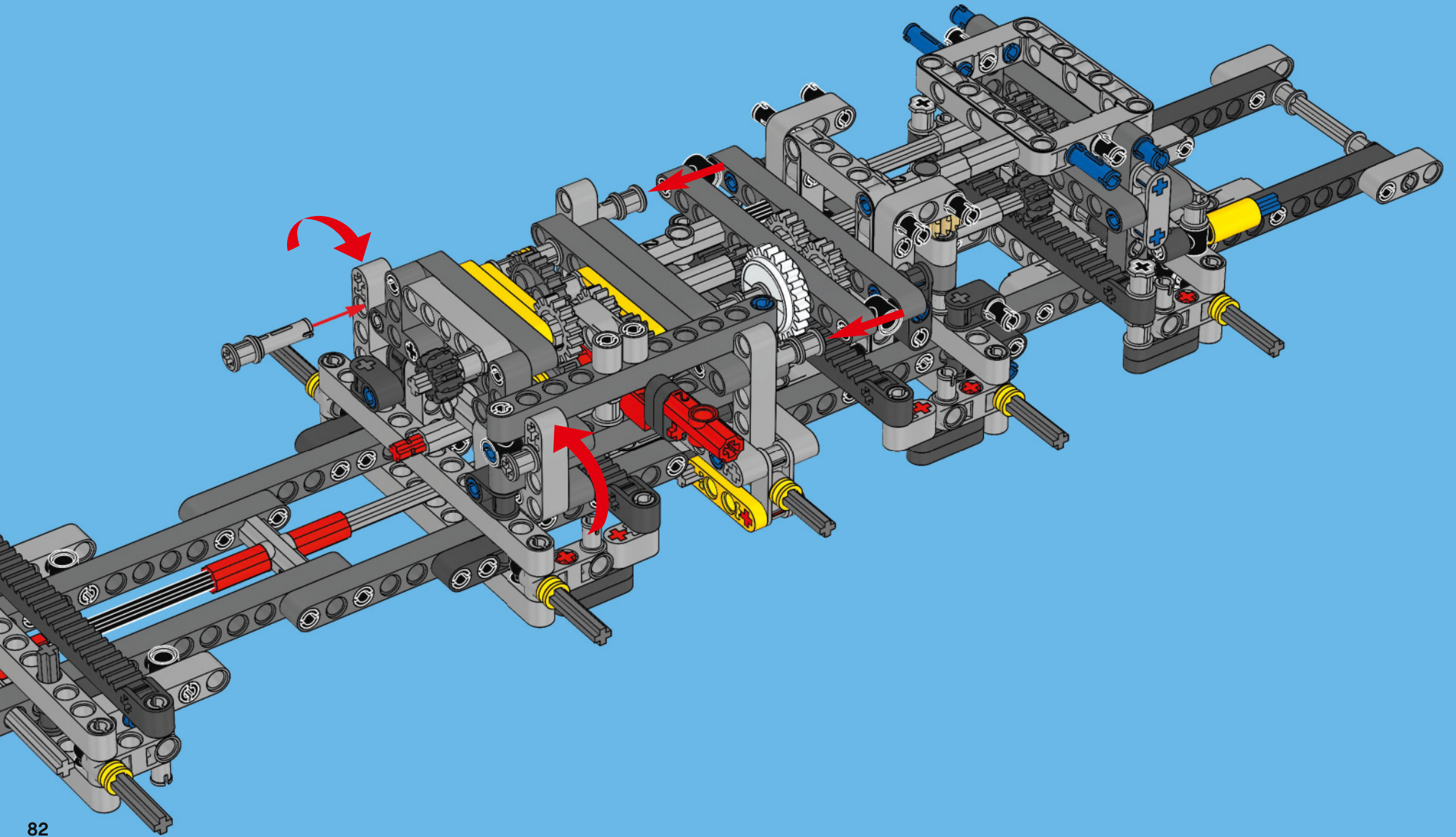



4x



2x



2x

# 75

1

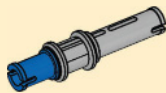

2

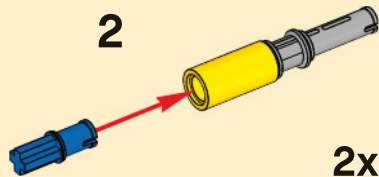

2x

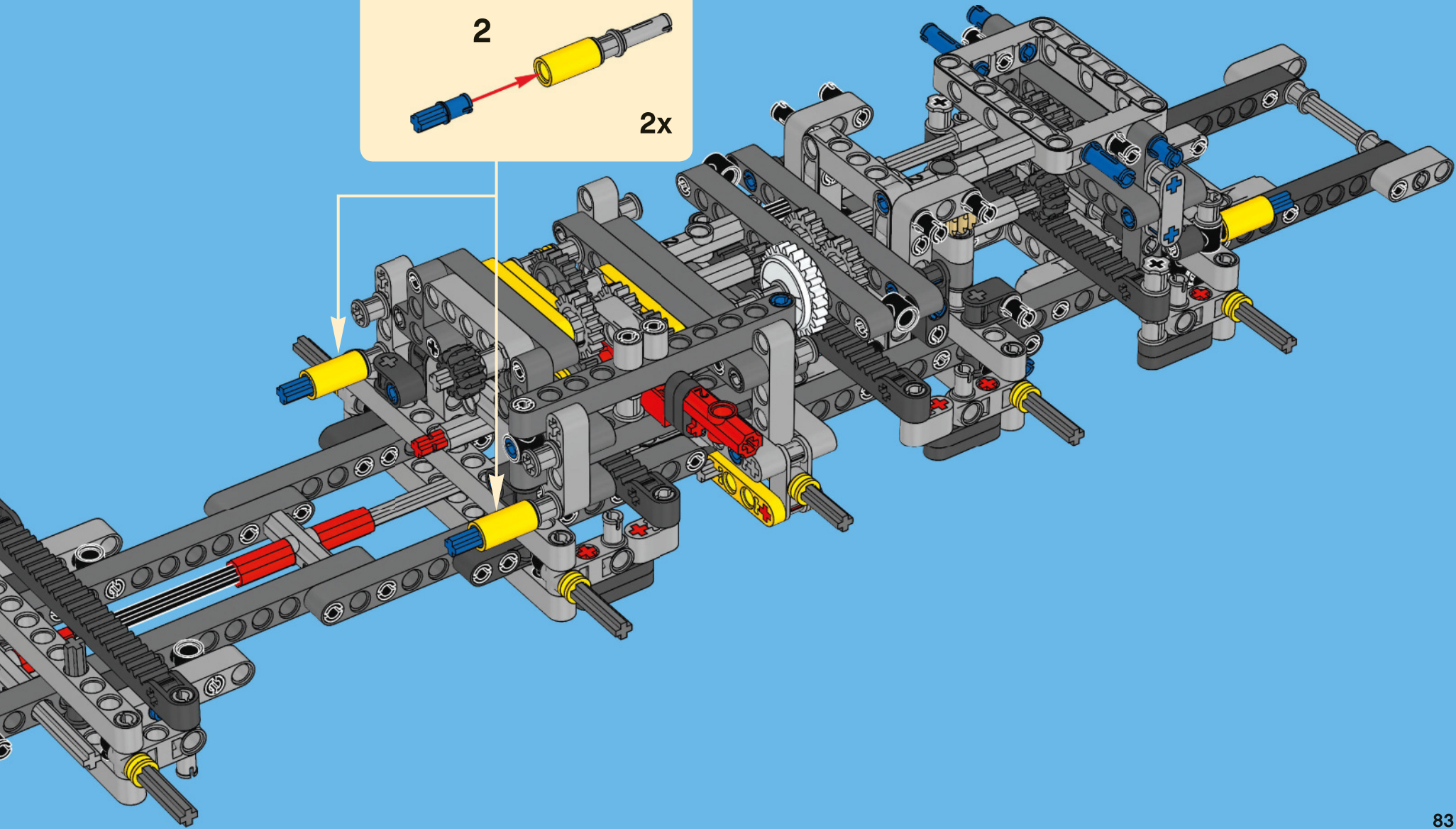



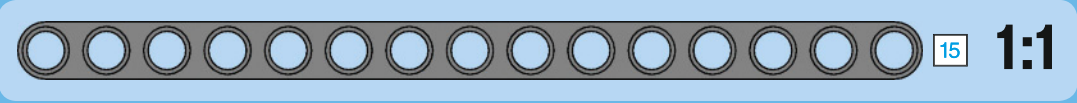
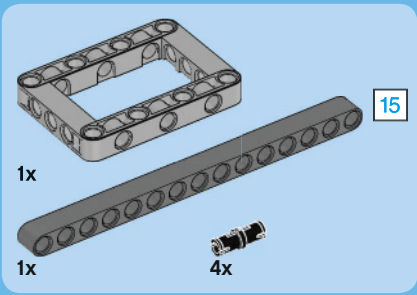

76

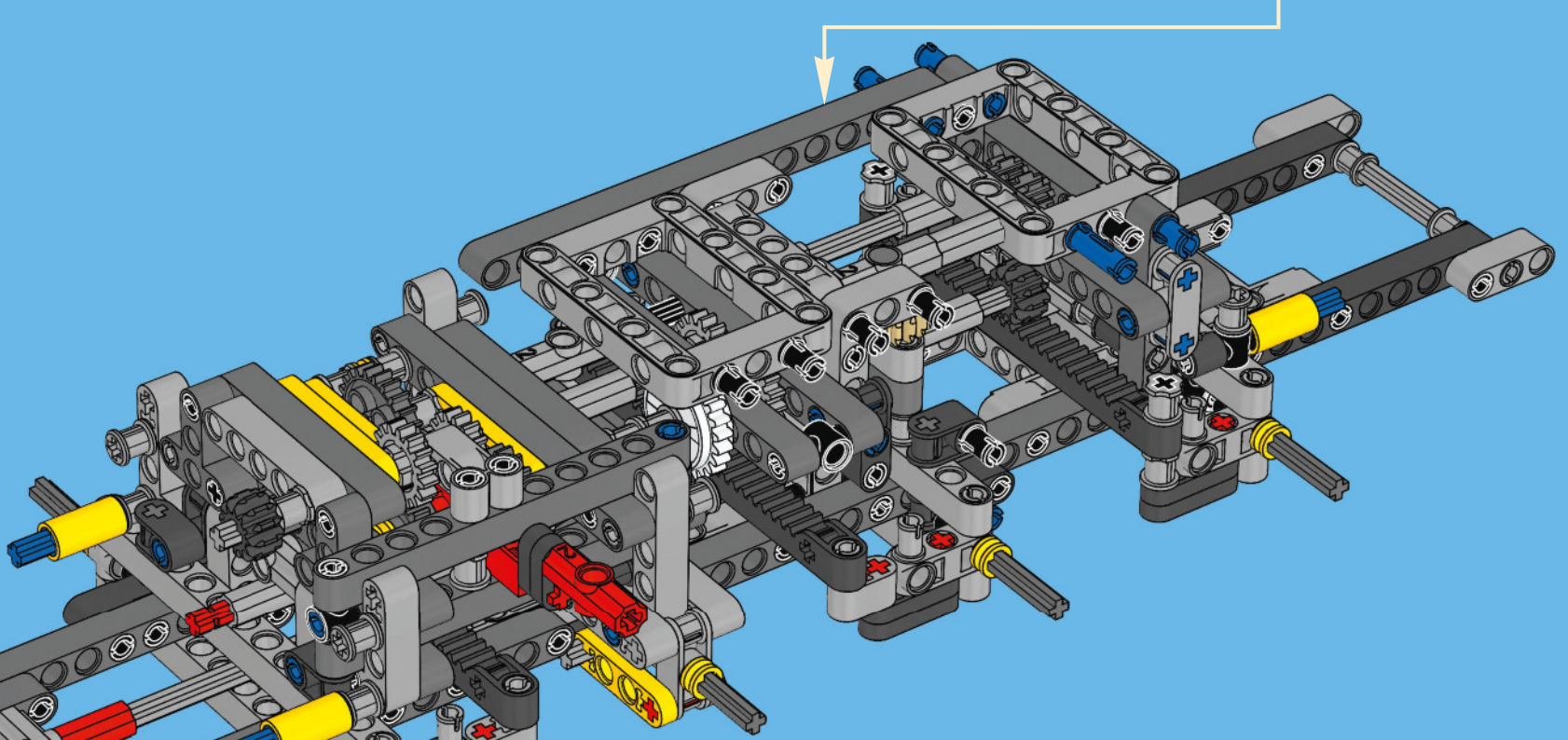
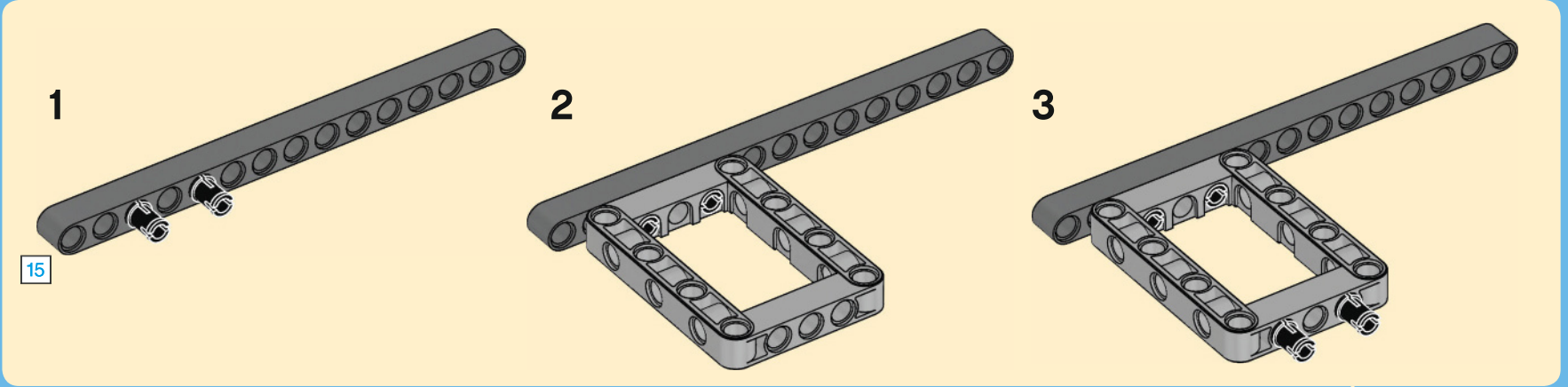



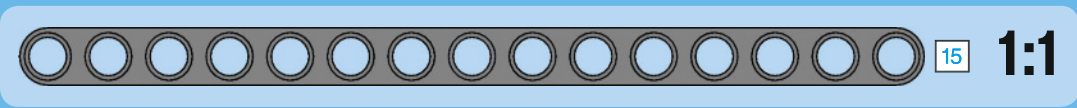
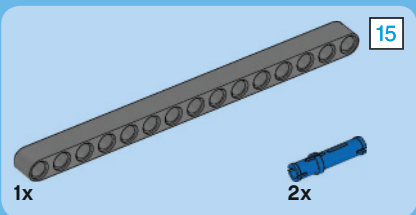

77

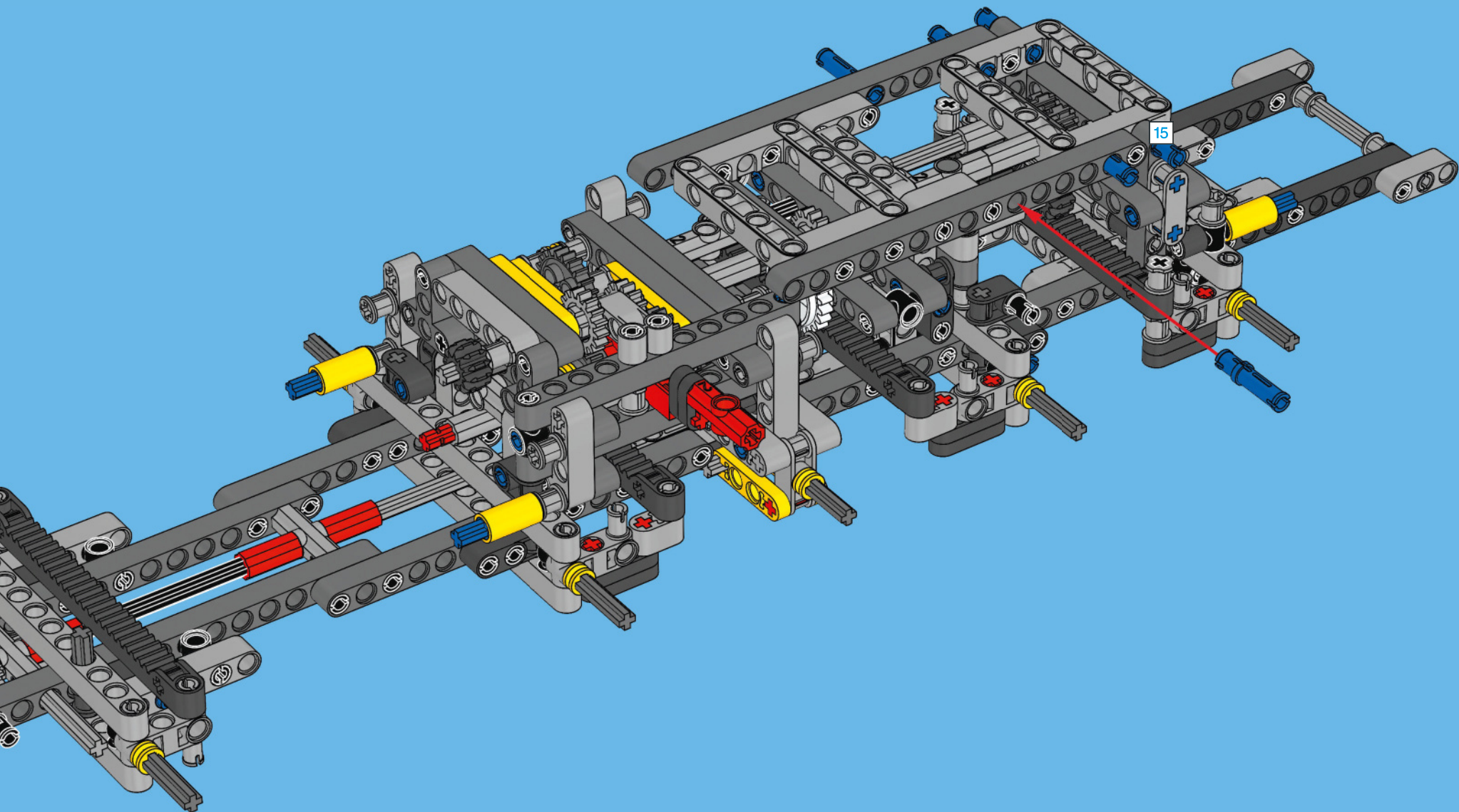

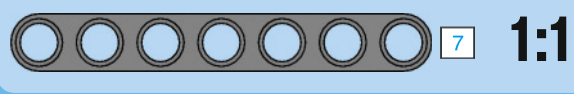
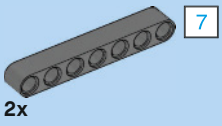

78

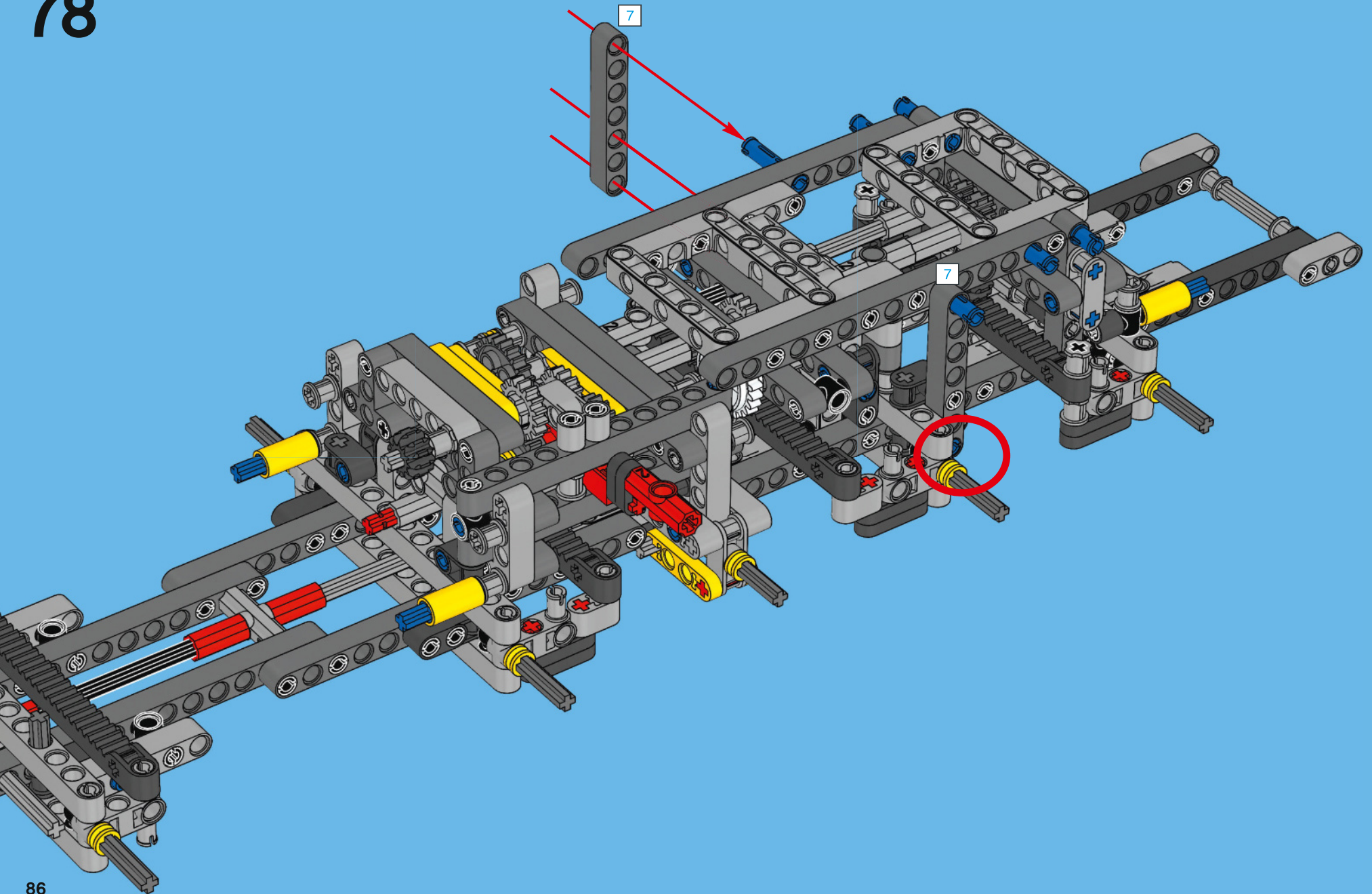





# 79

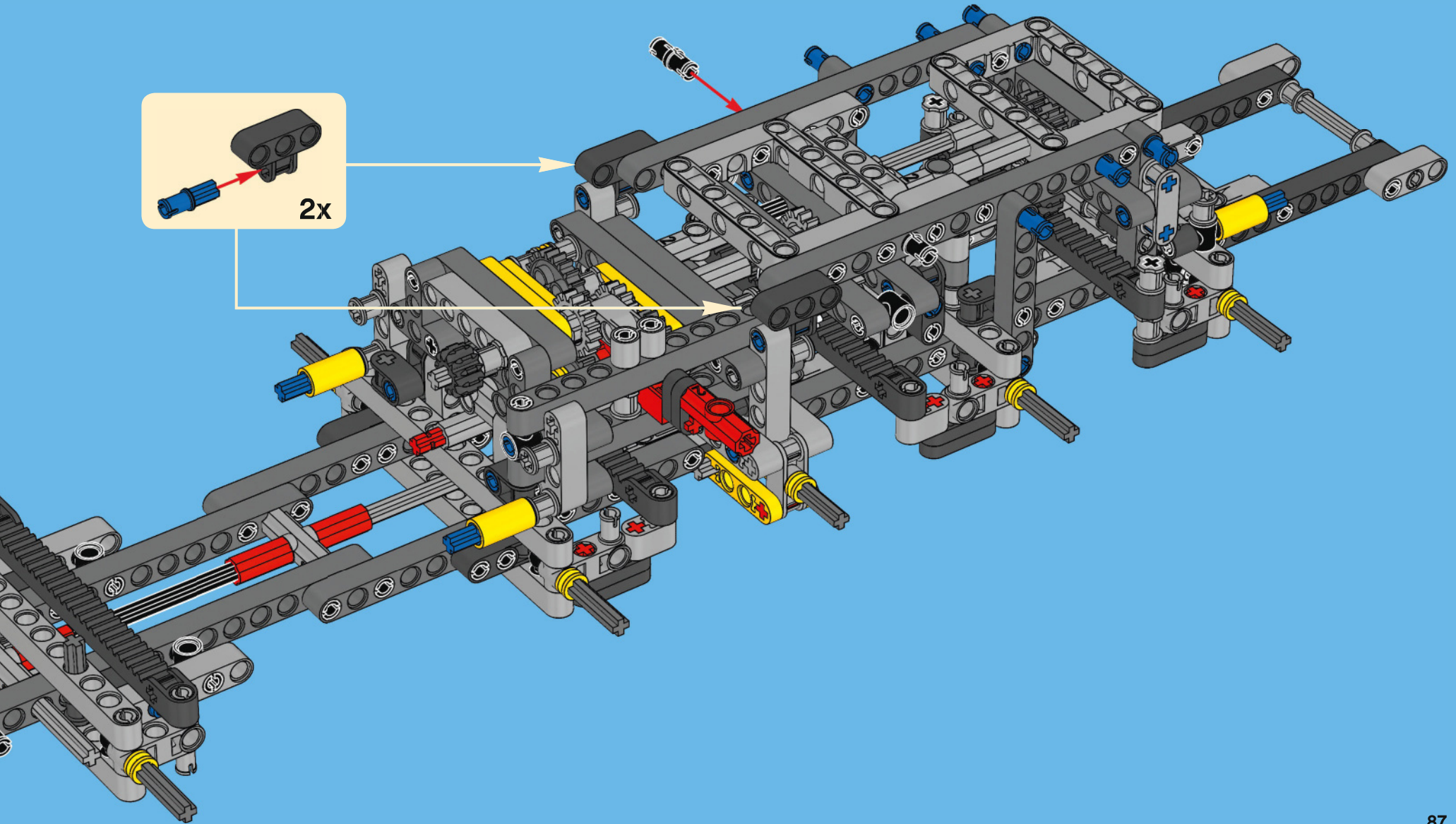
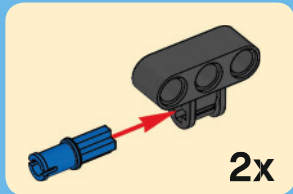



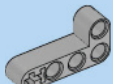

4x



2x

# 80

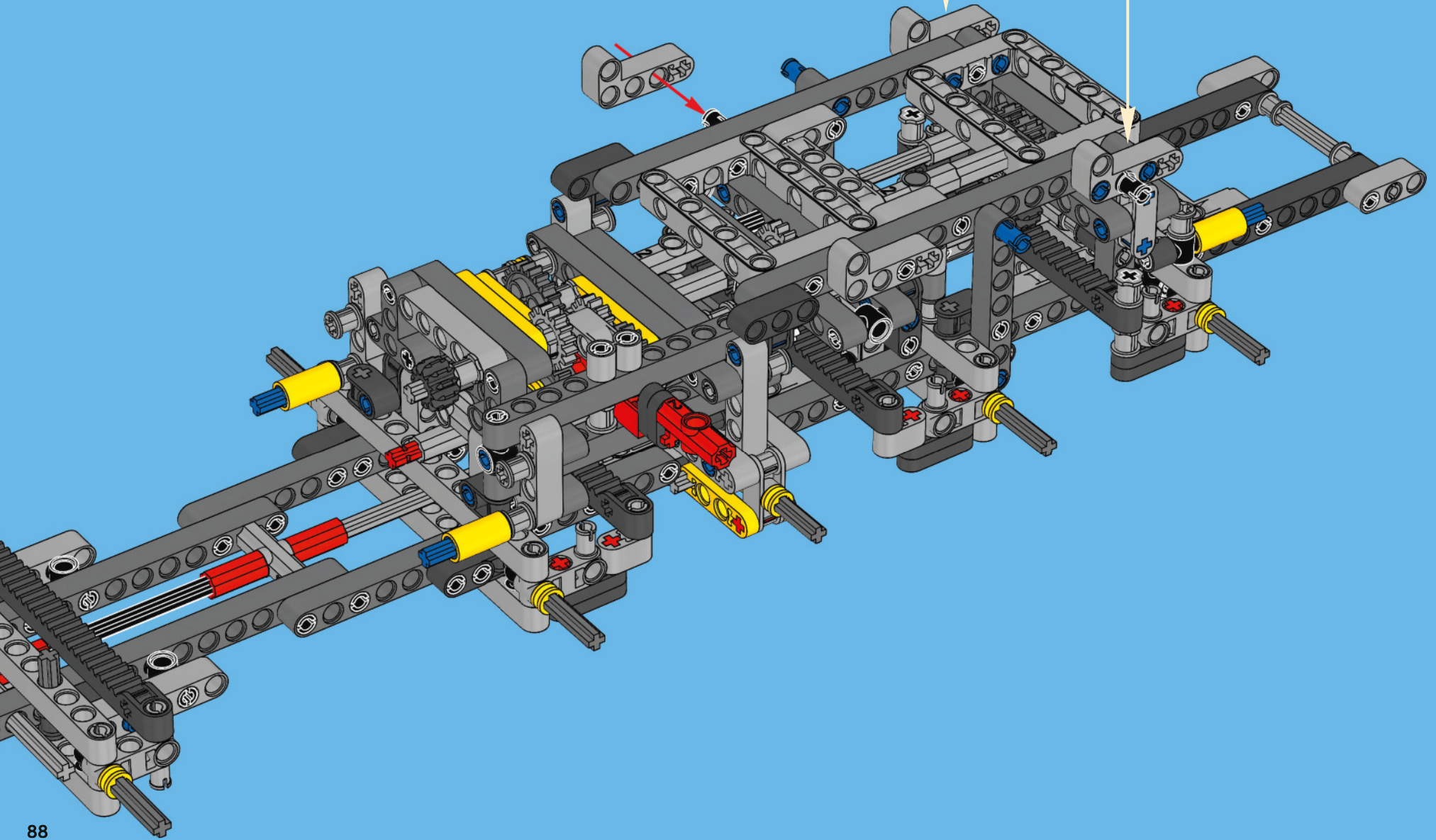
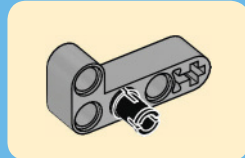
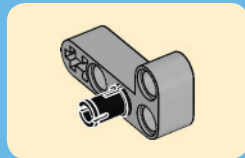



2x



4x

# 81

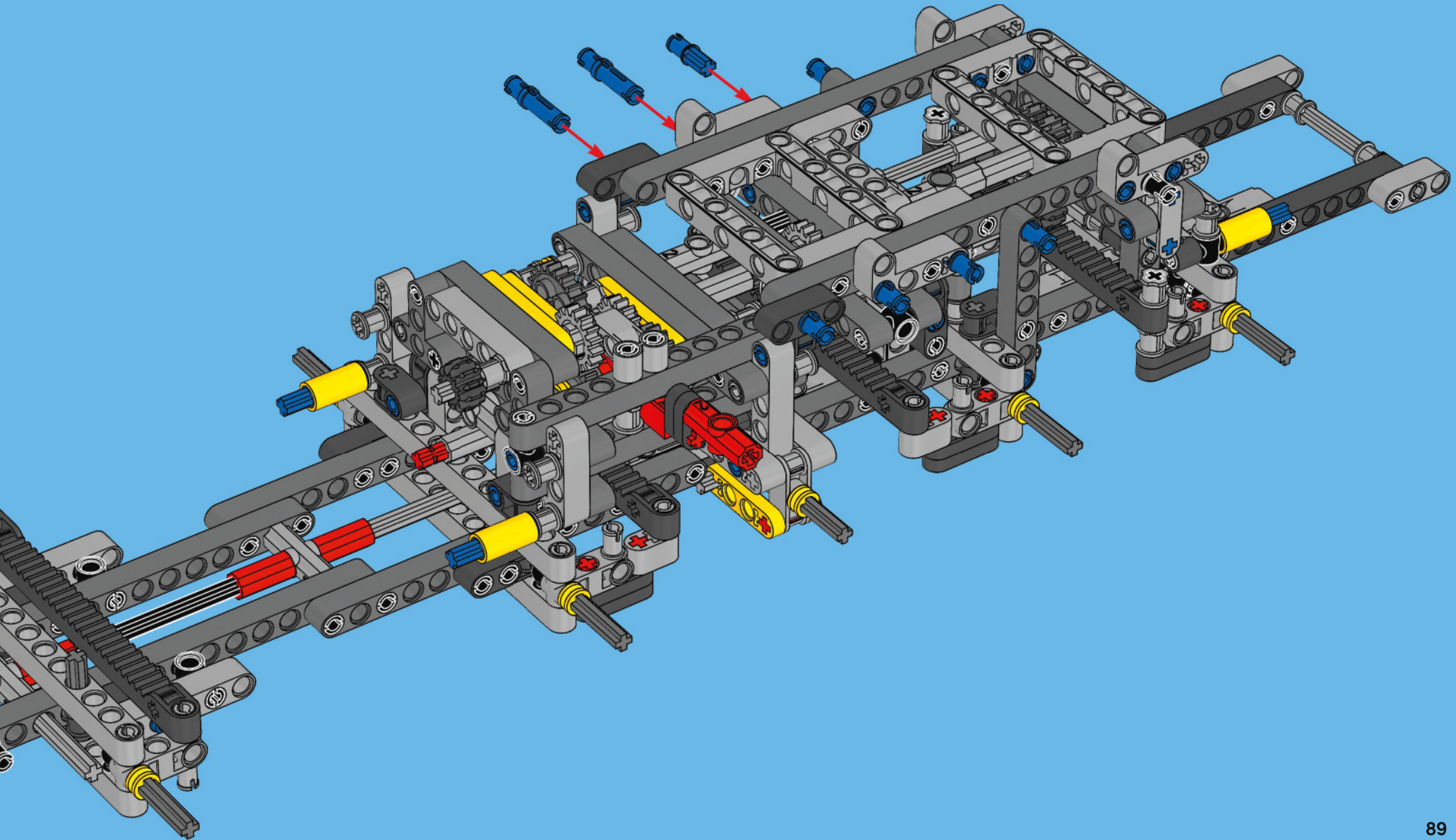



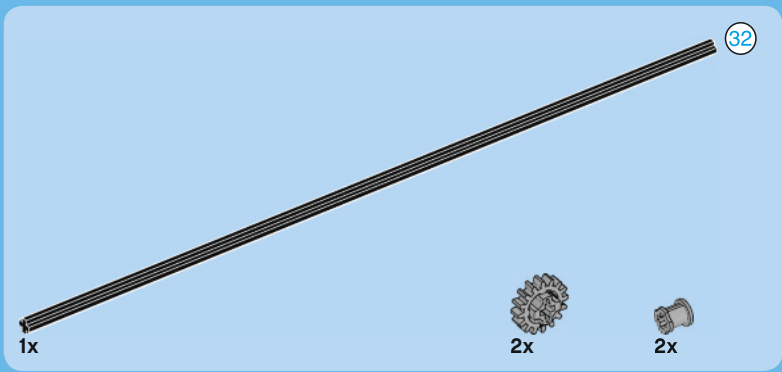

# 82

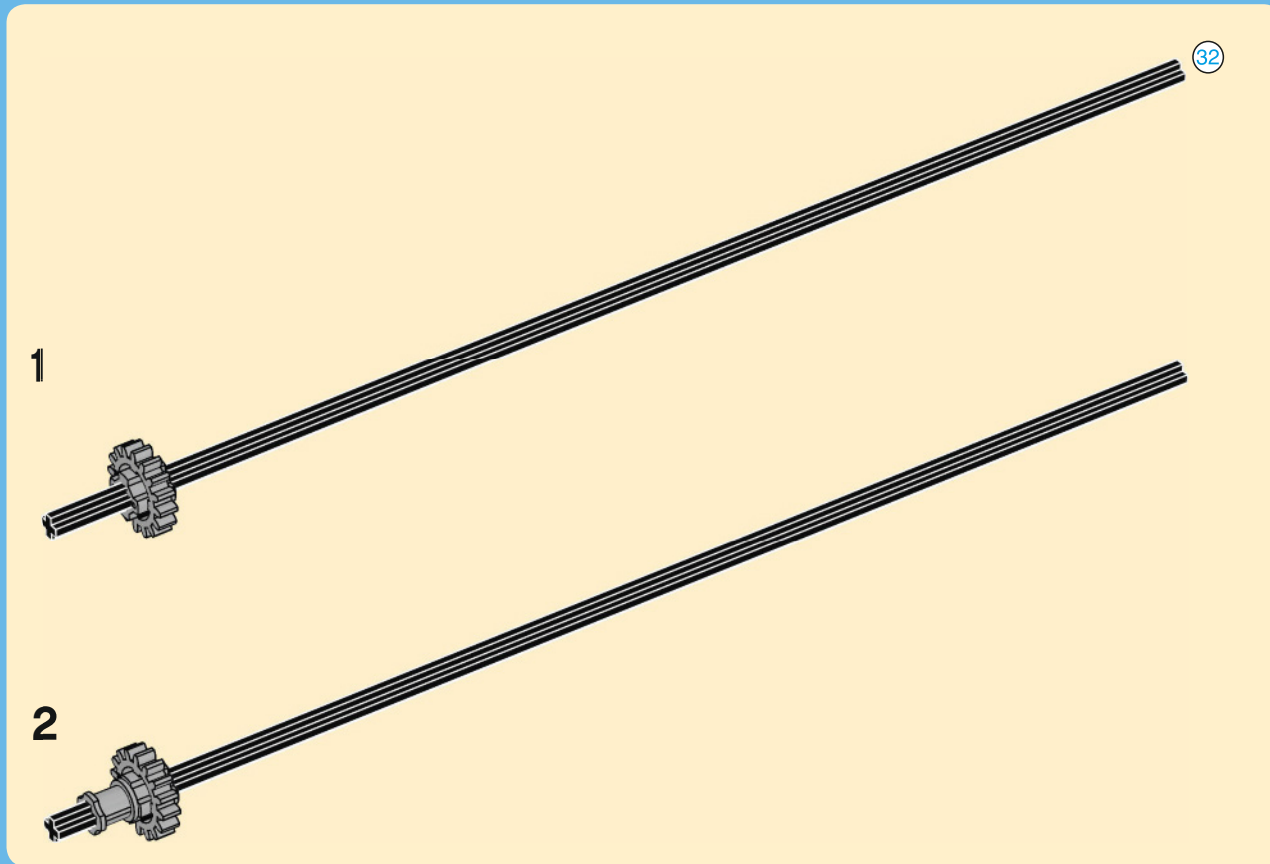

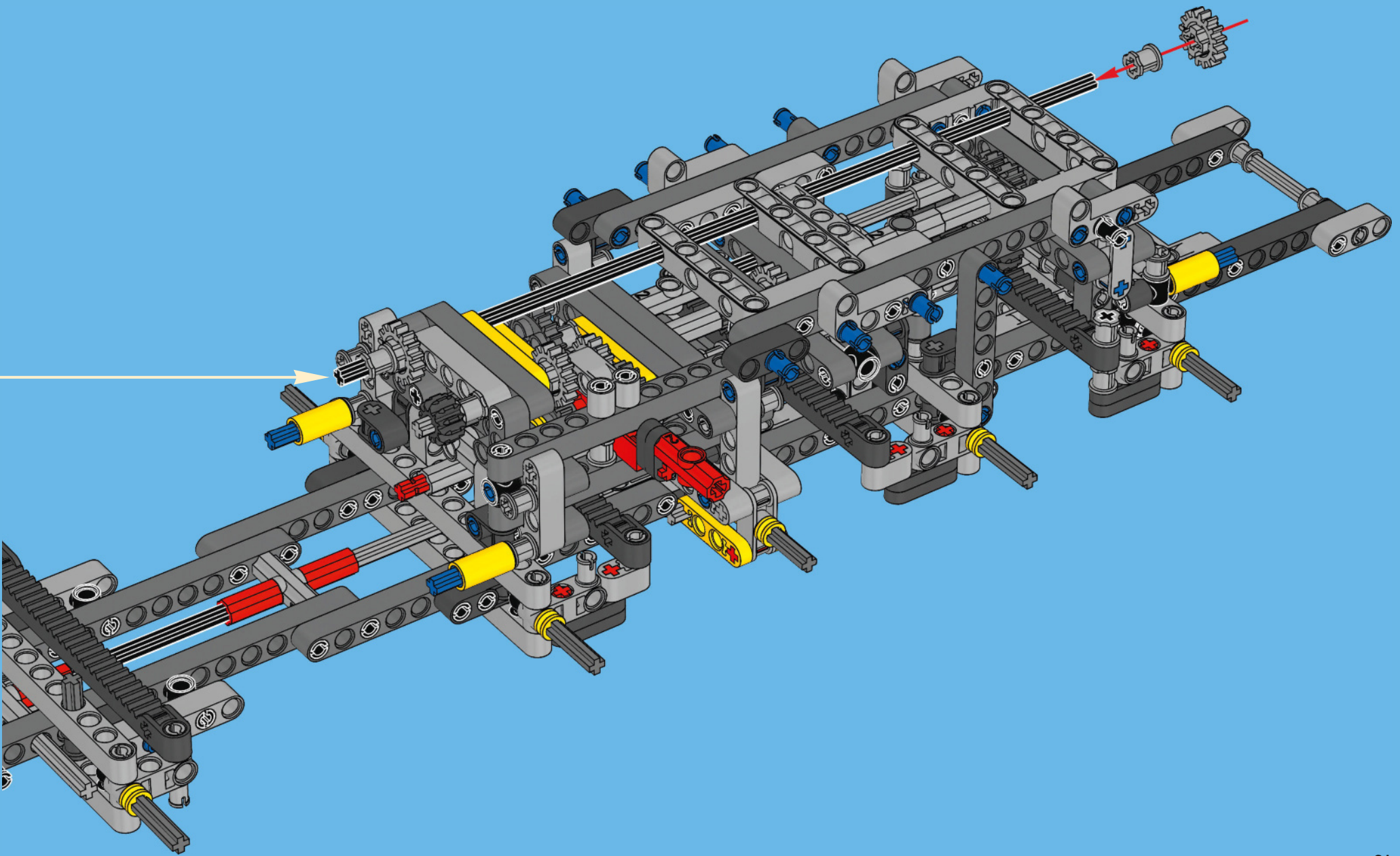





2x



2x

# 83



2x

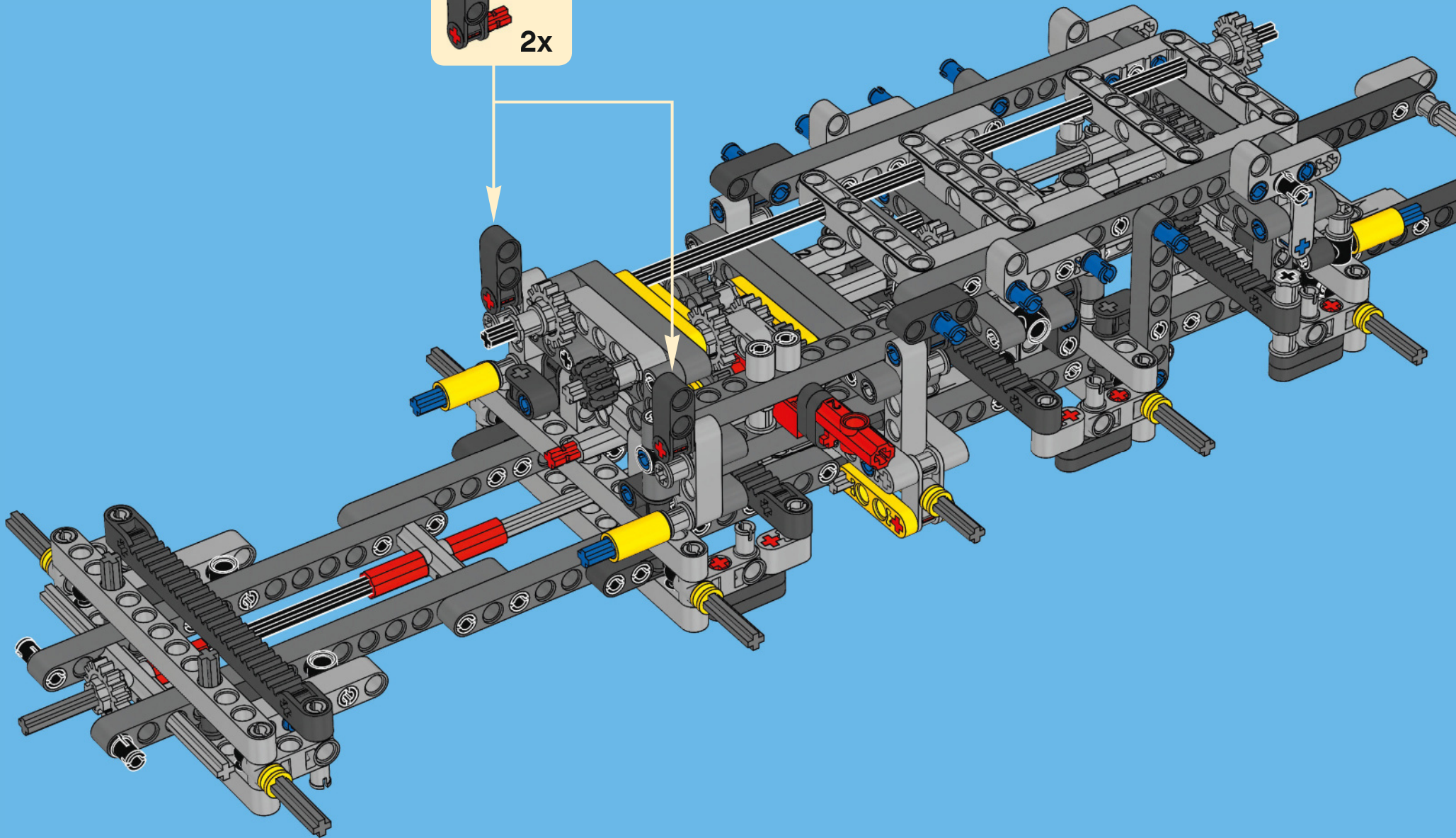

2x

4x

# 84

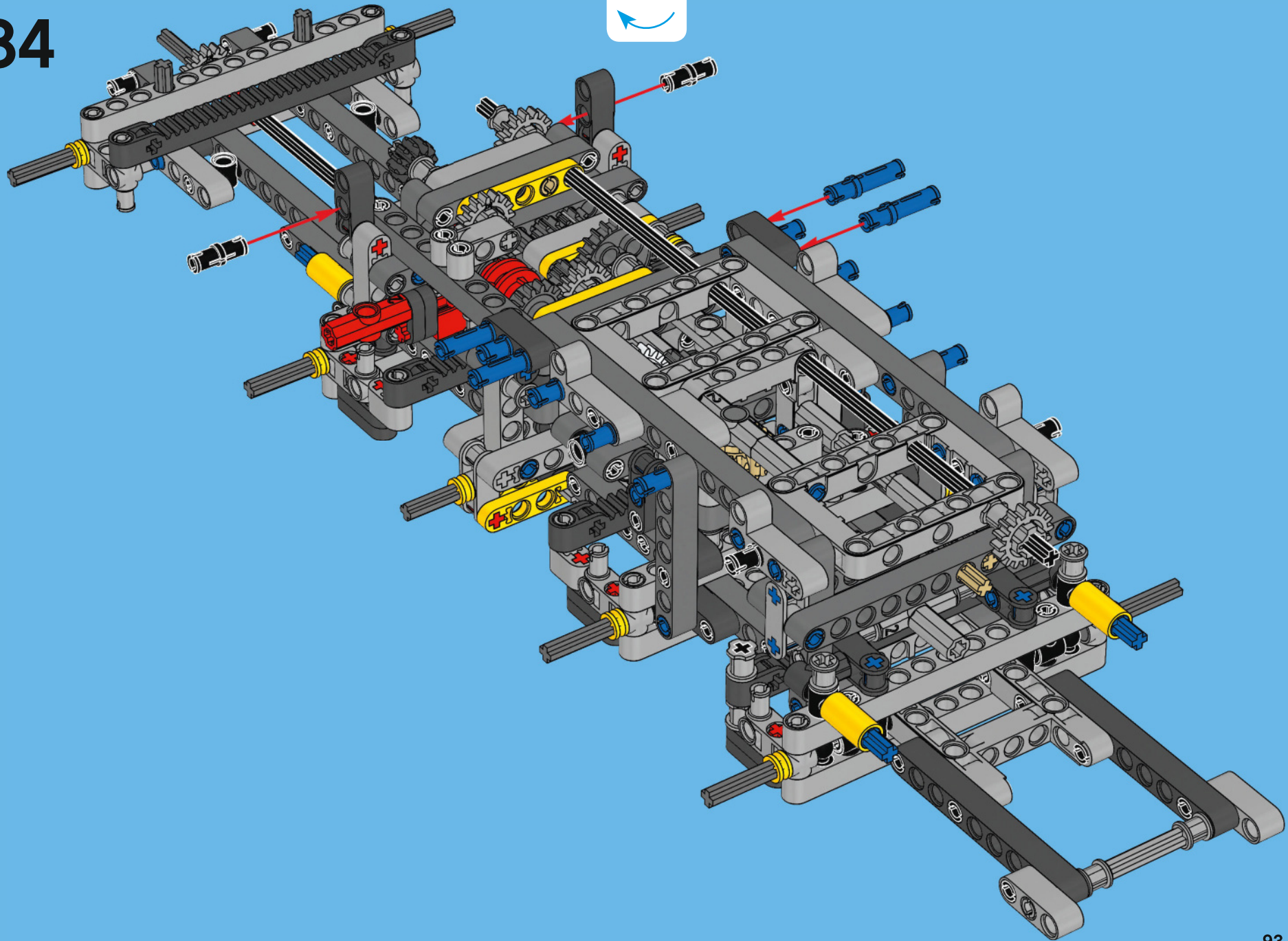

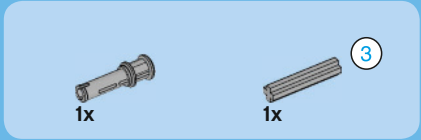
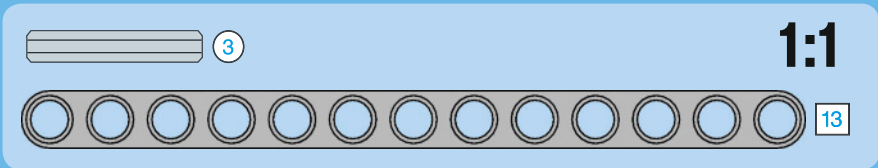
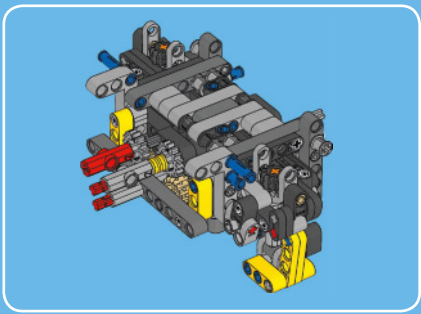

1

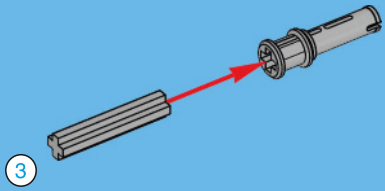

2

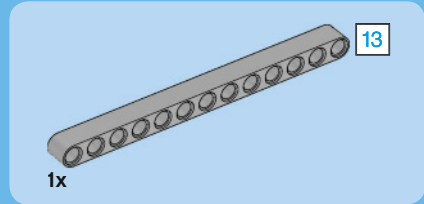
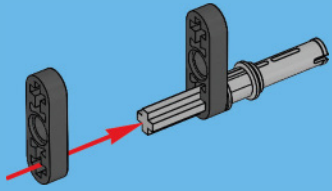

3

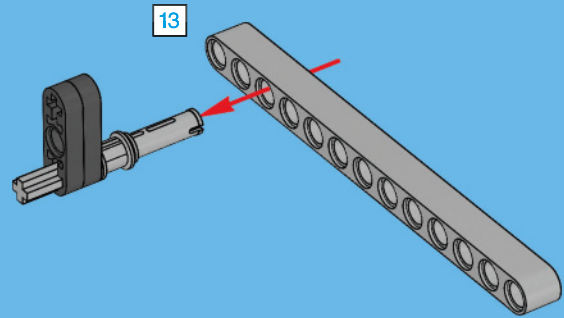

4

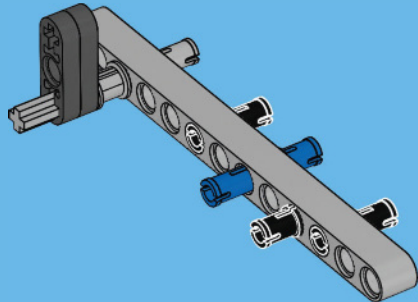



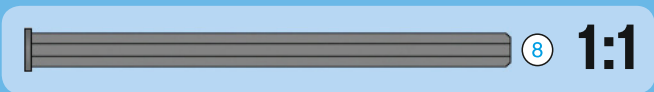
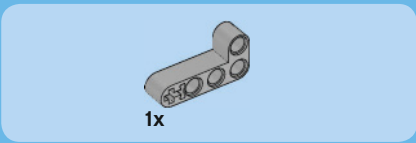

5

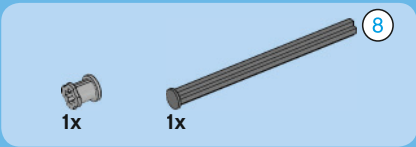
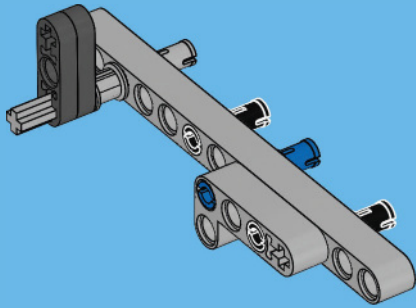

6

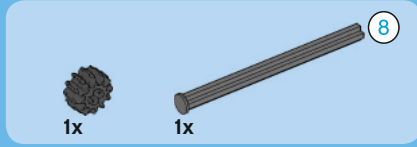
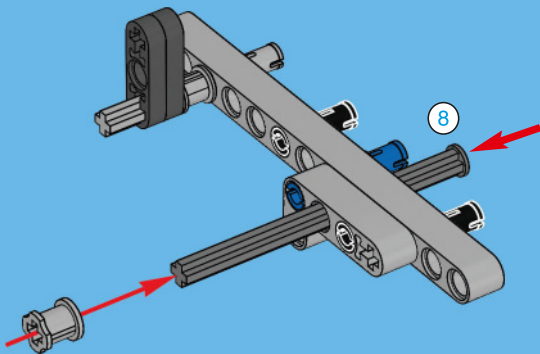

7

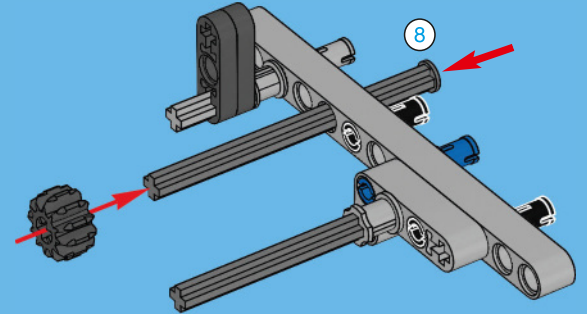

8

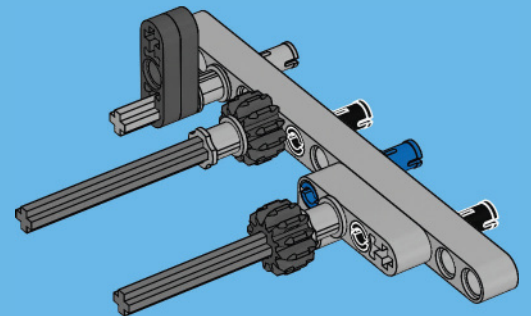

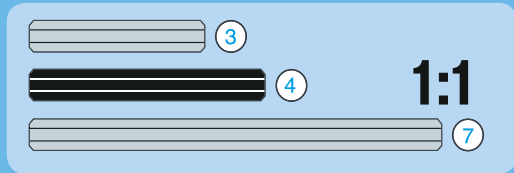
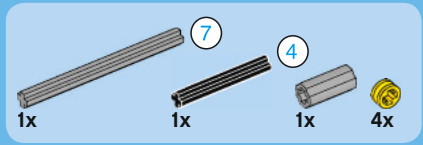

9

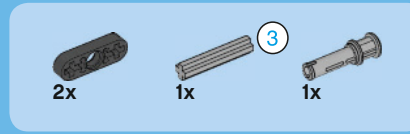
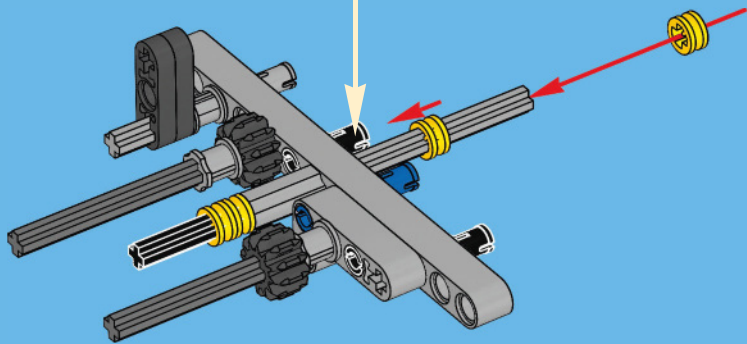
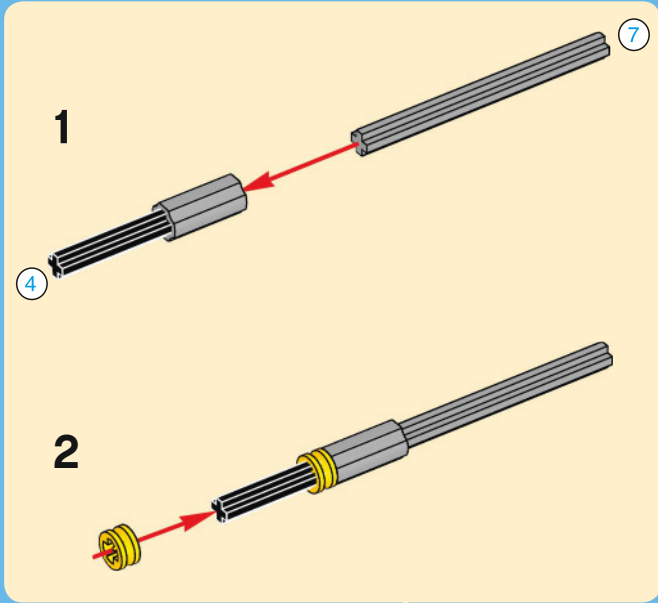

10

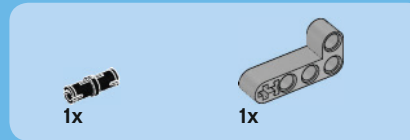
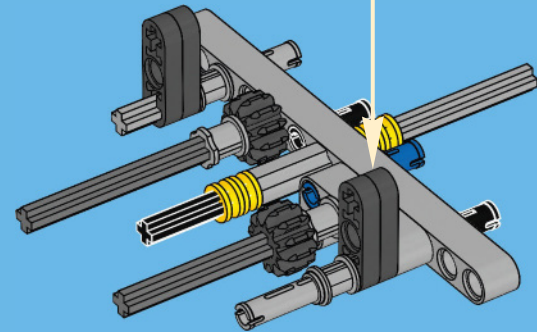
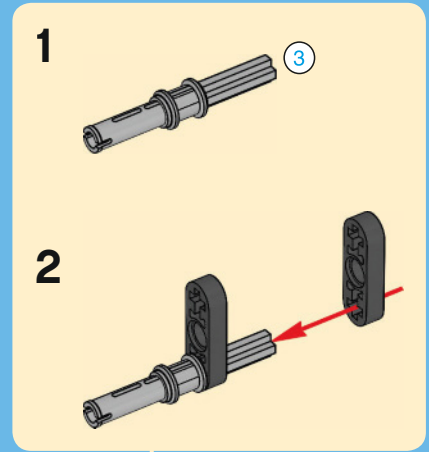

11

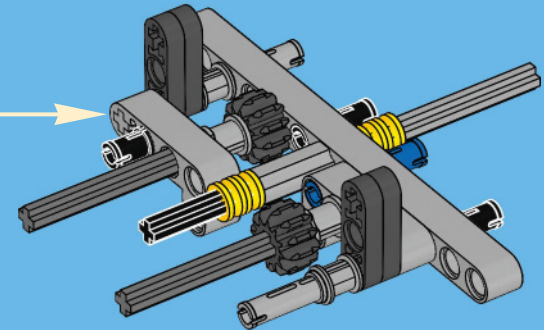
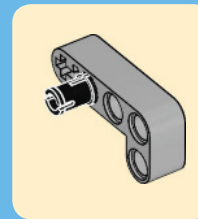

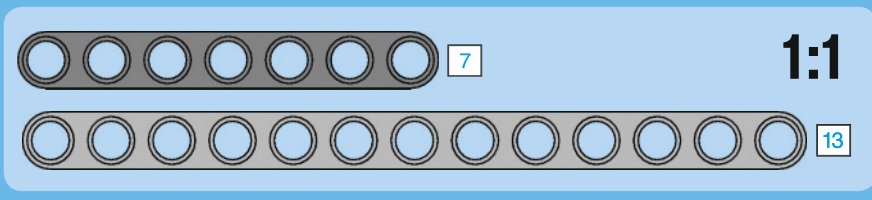
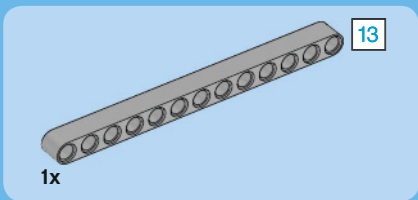

12

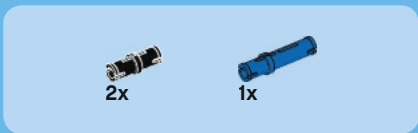
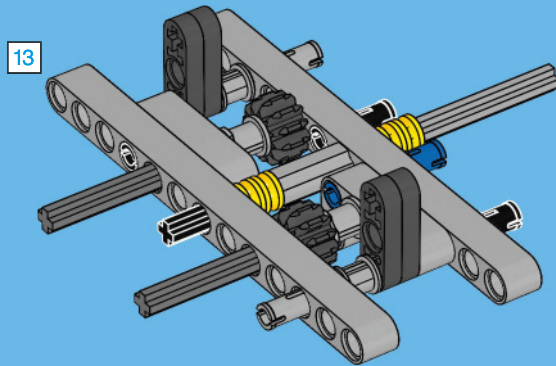

13

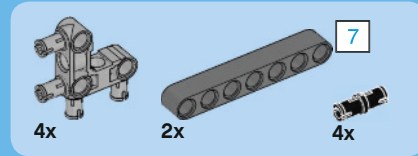
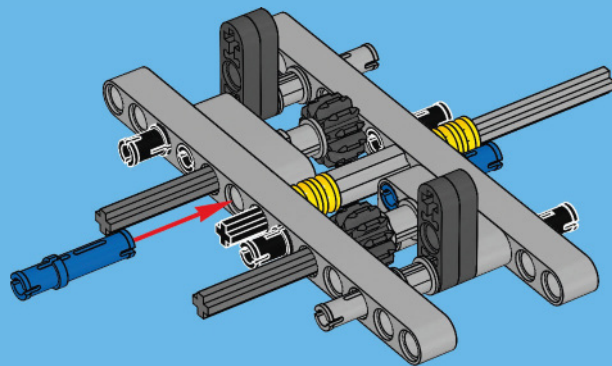

14

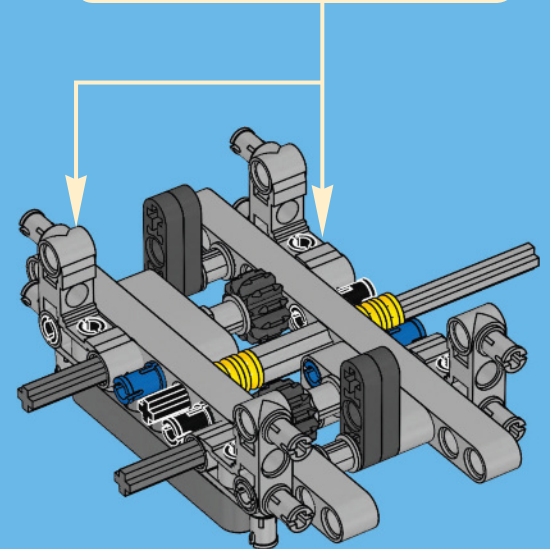
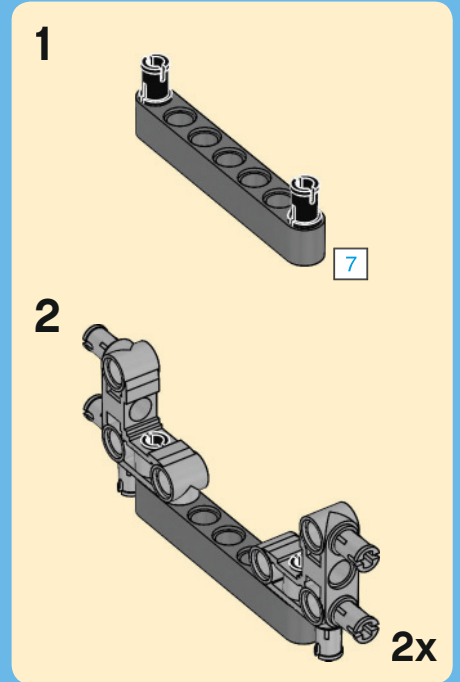



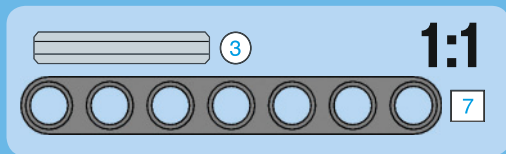
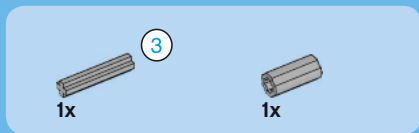

15

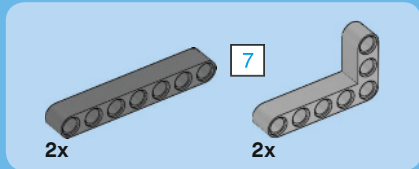
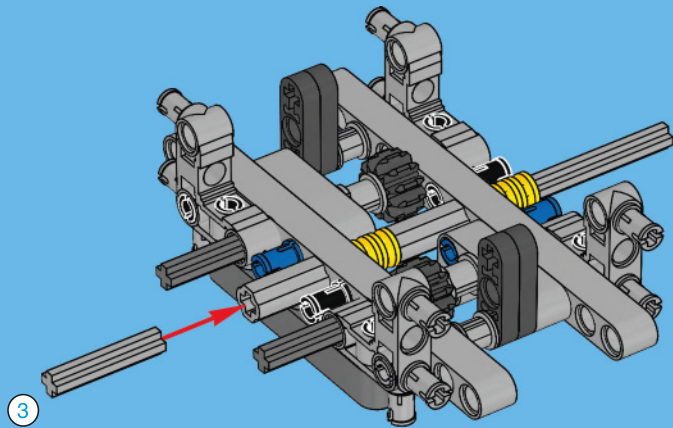

16

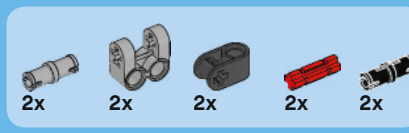
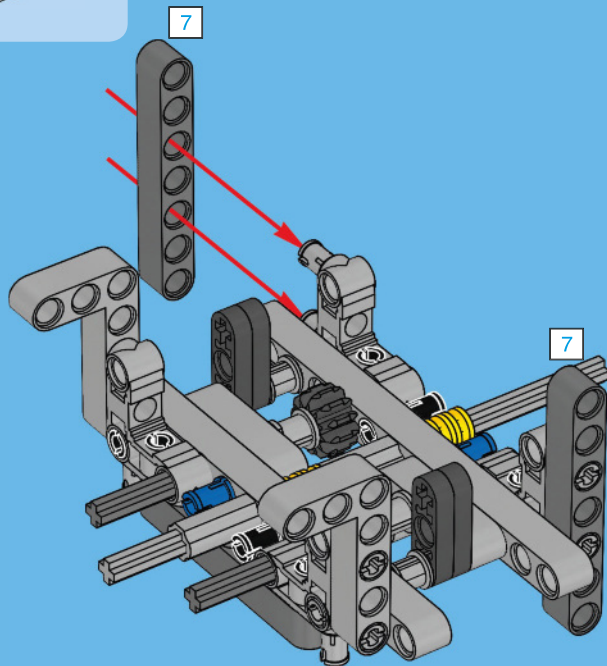

17

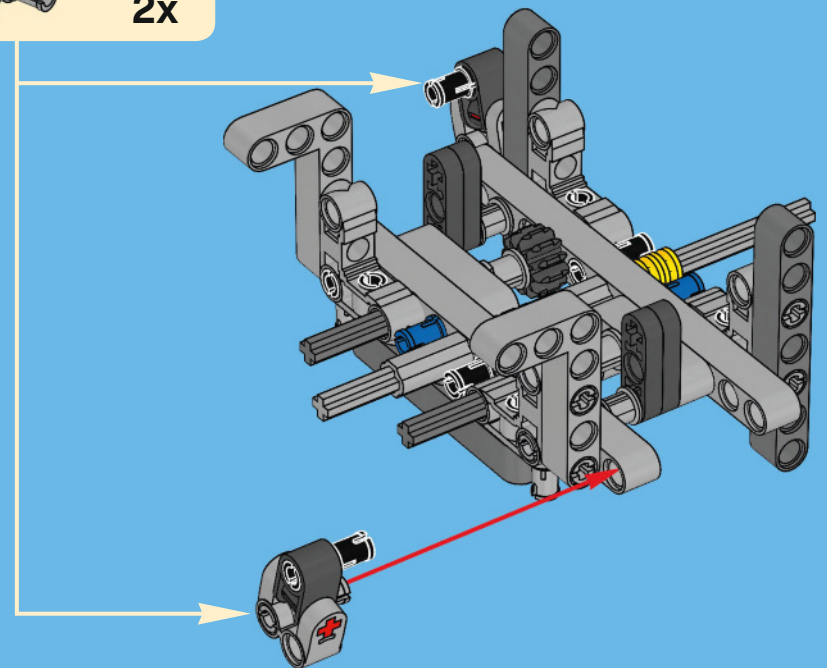
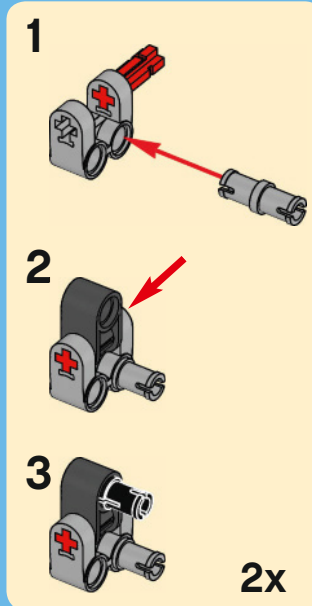

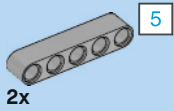

18

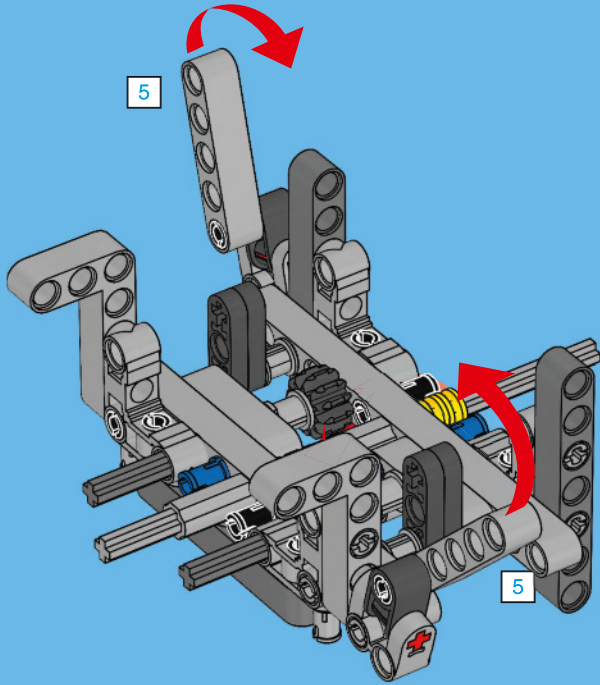

19

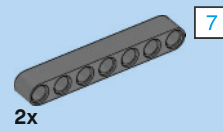
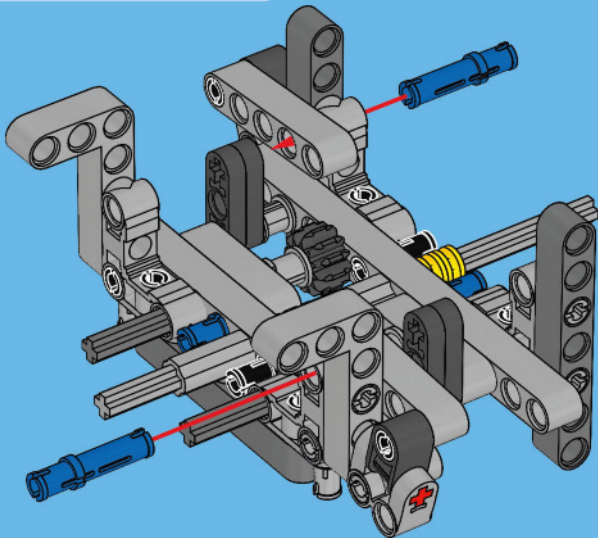

20

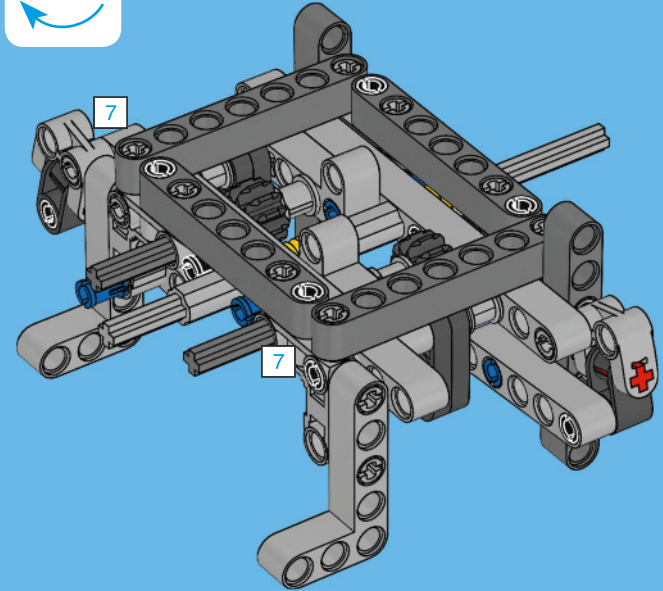

21

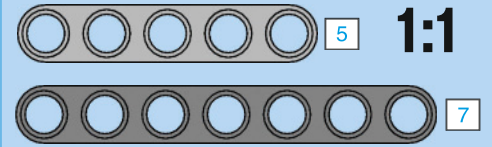
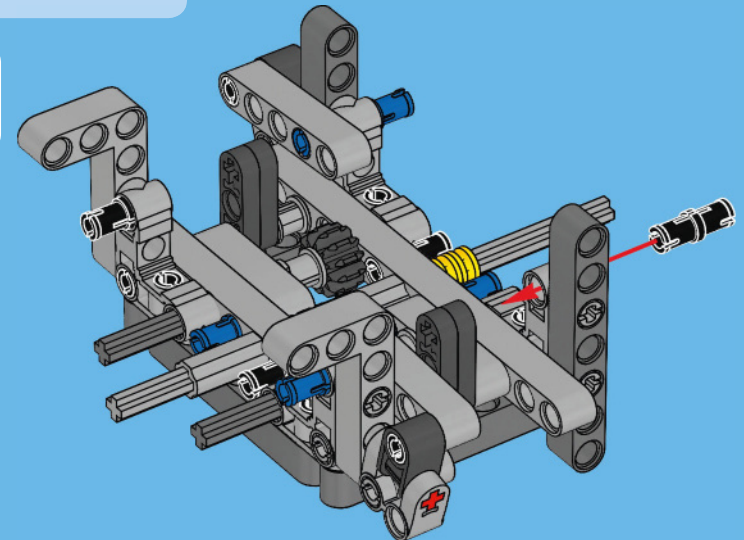

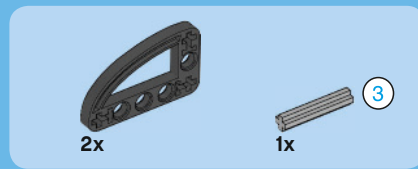
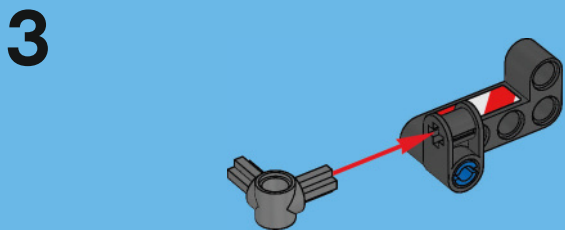
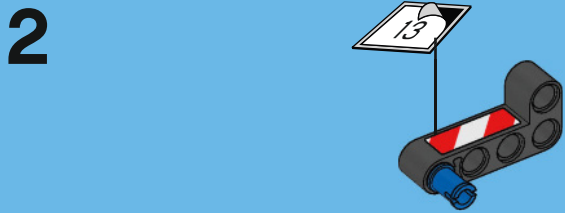

**4**

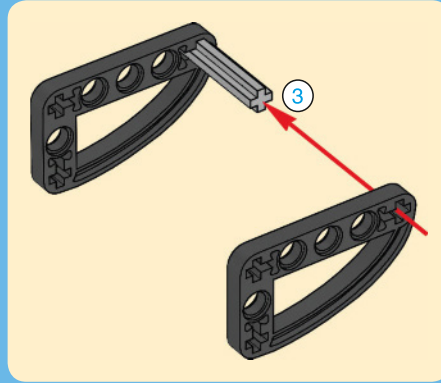

**5**

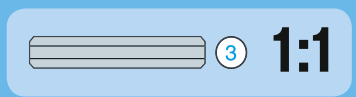
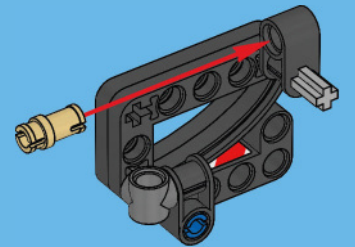



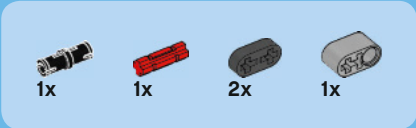

6

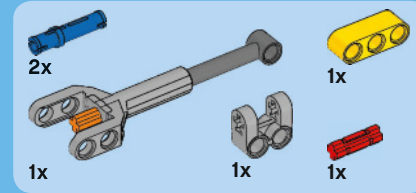
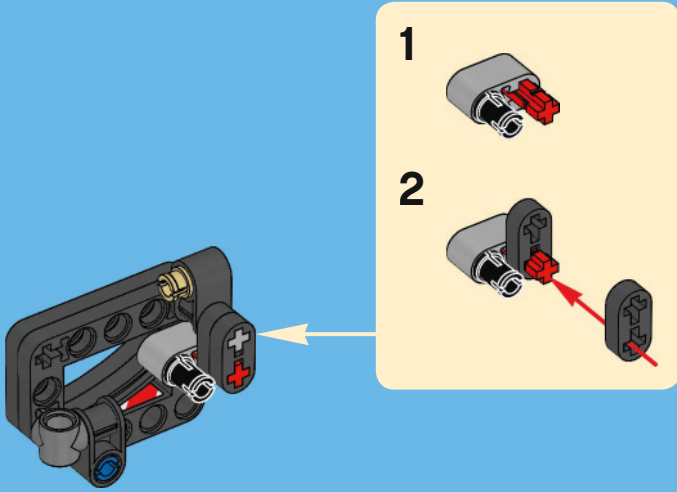

7

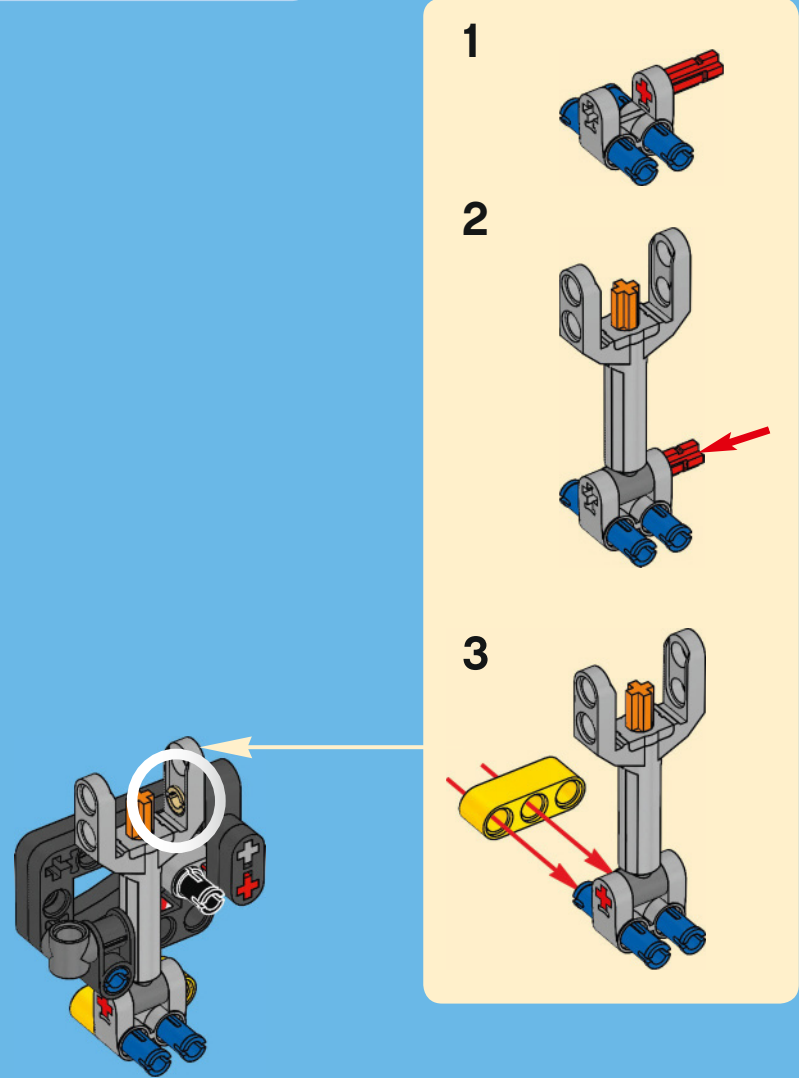



8

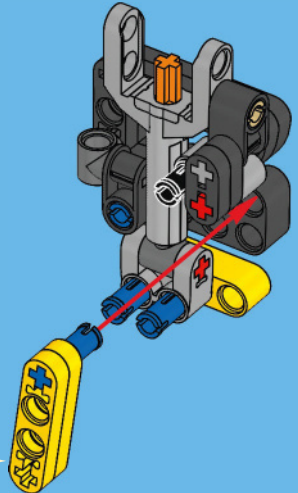
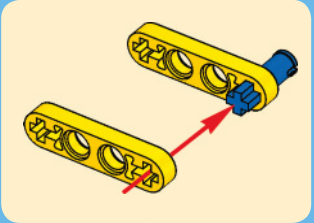

9

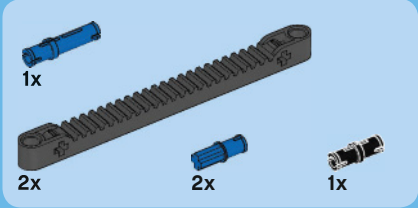
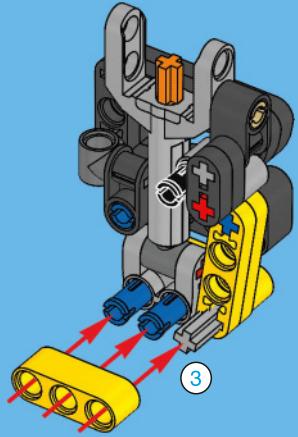
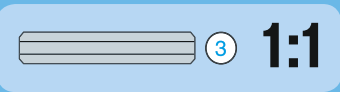

10

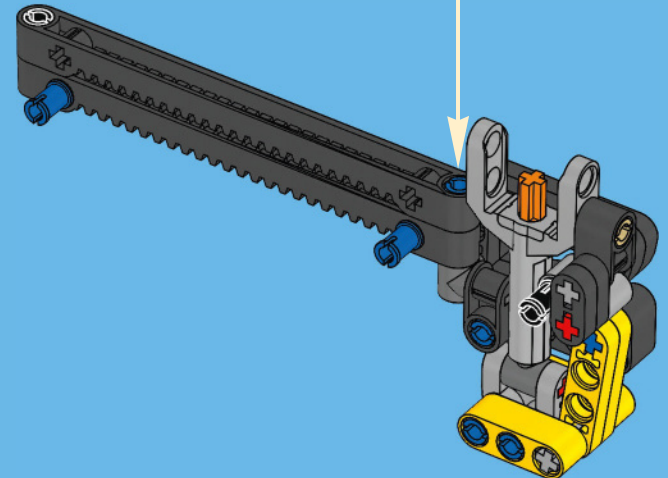
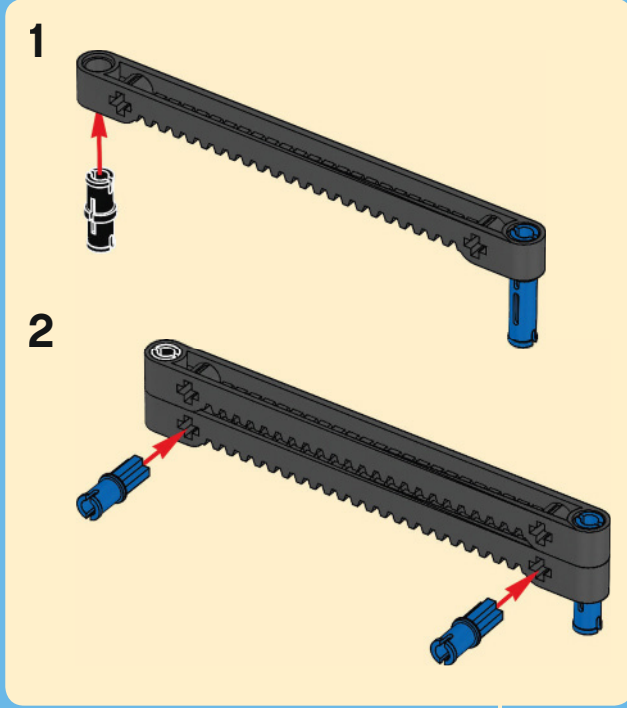

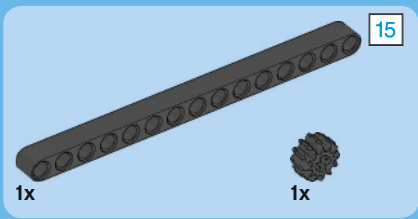

11

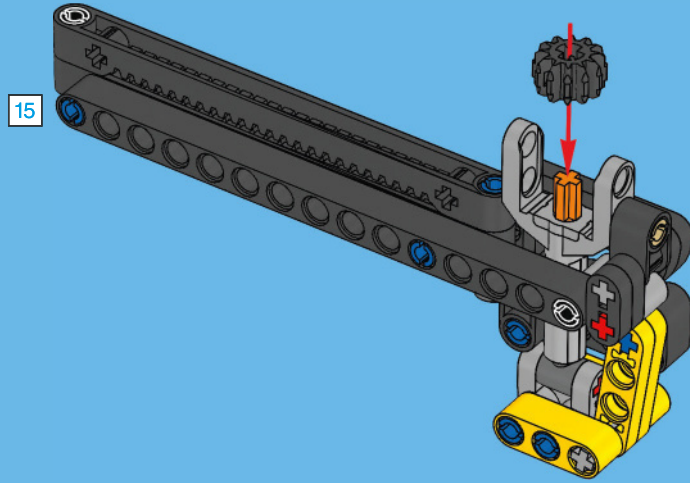

2x



22

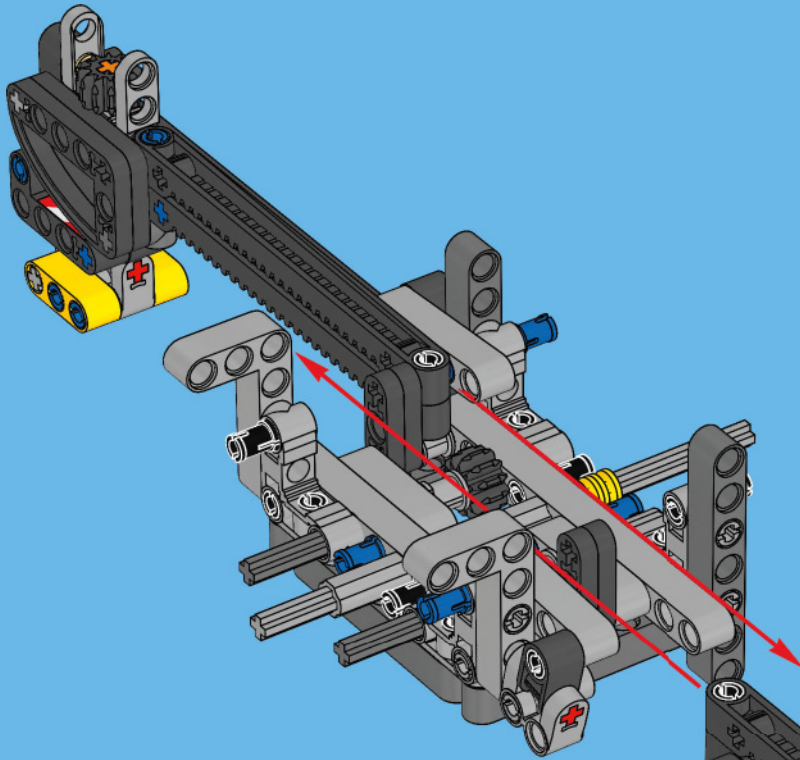

23

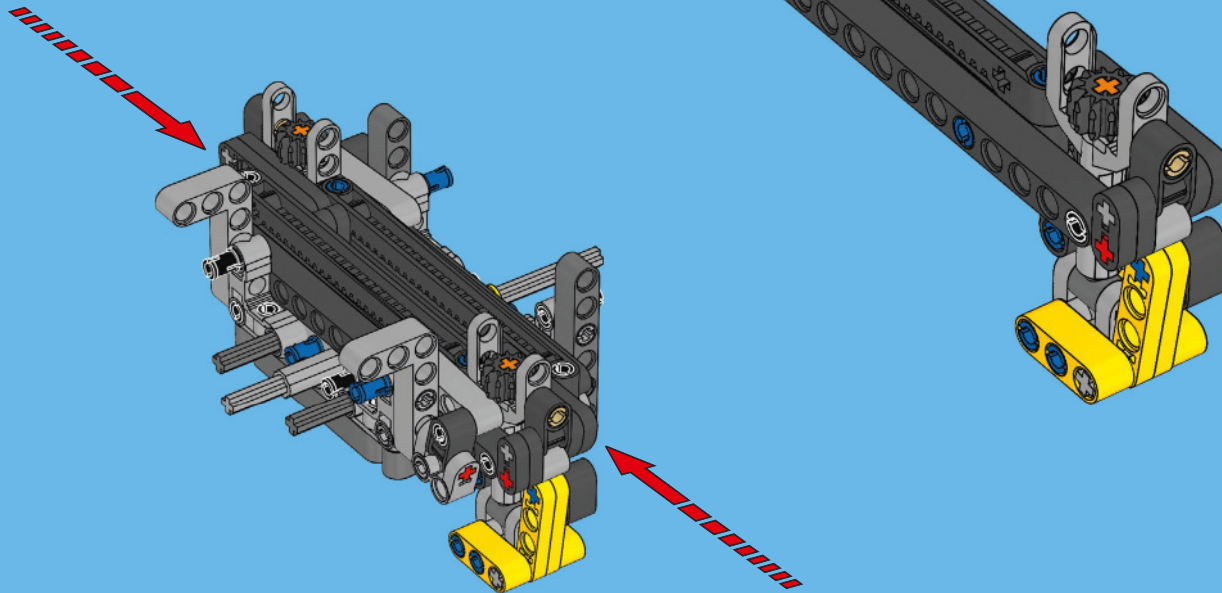

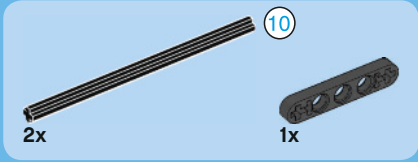
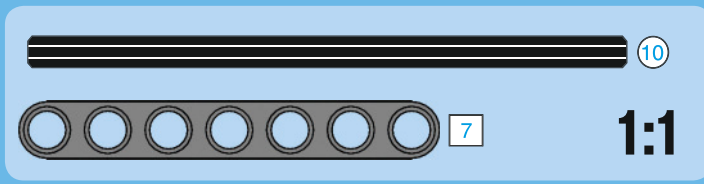
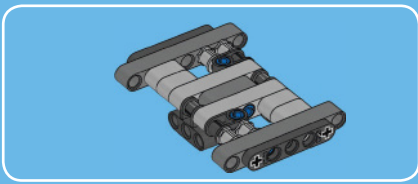

1

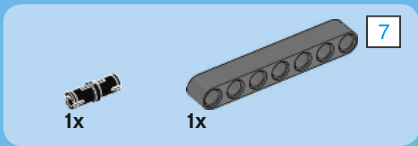
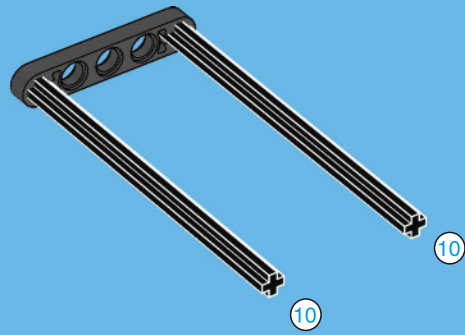

2

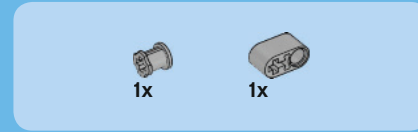
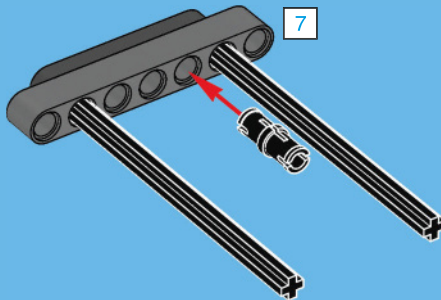

3

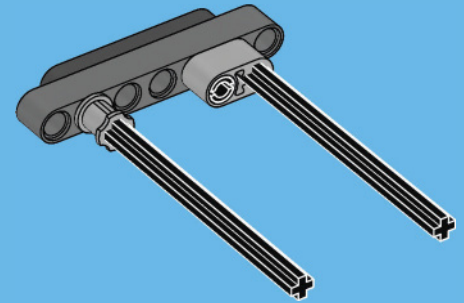

4

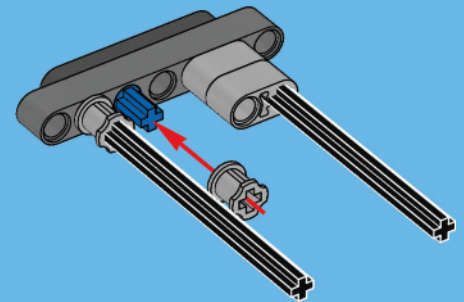

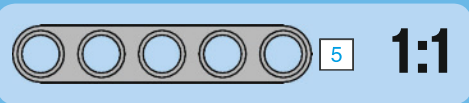
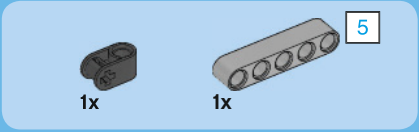

5

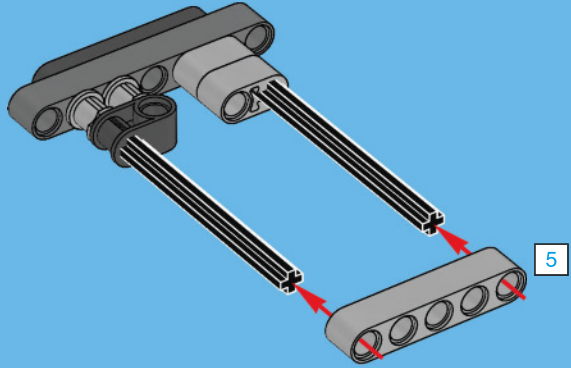

6

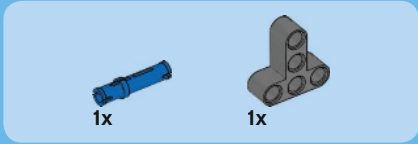
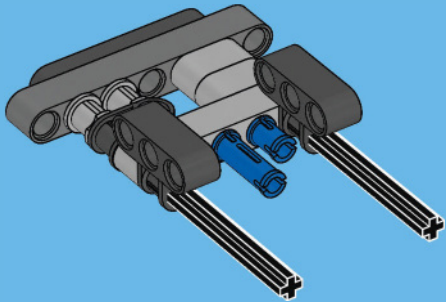

7

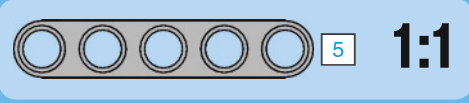
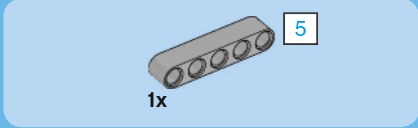
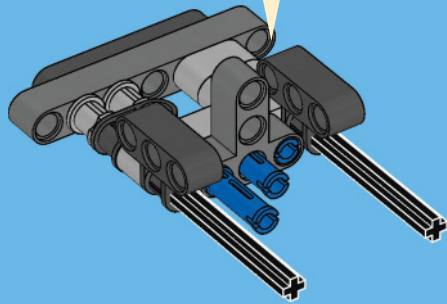
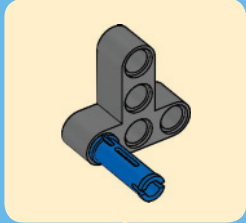

8

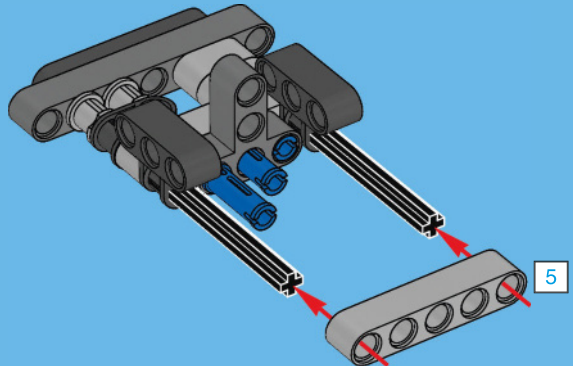





9

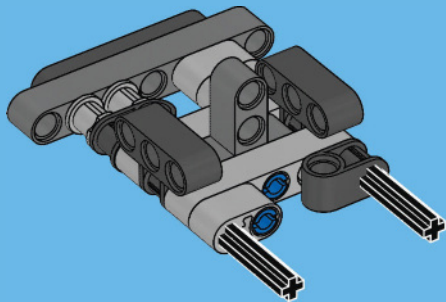

10

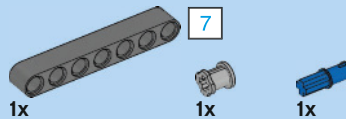
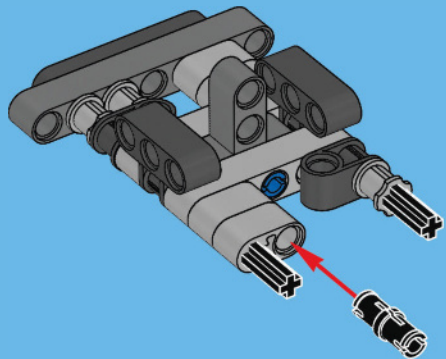

11

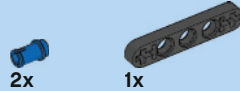
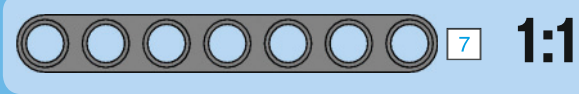
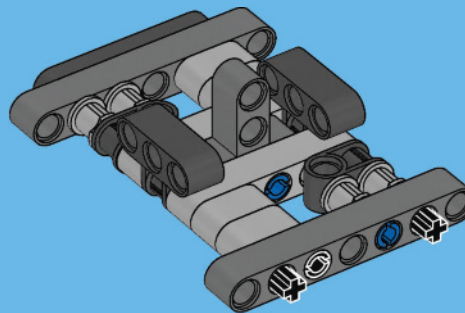

12

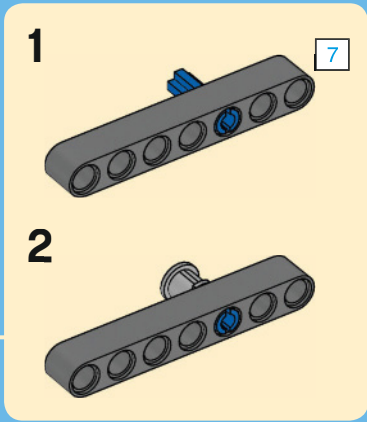
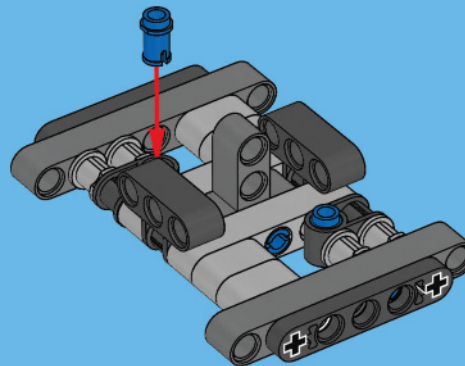

13

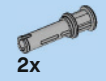
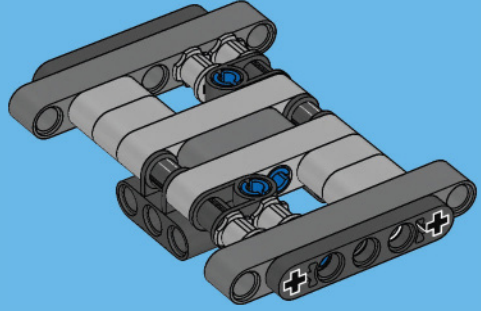

2x



2x

25

24

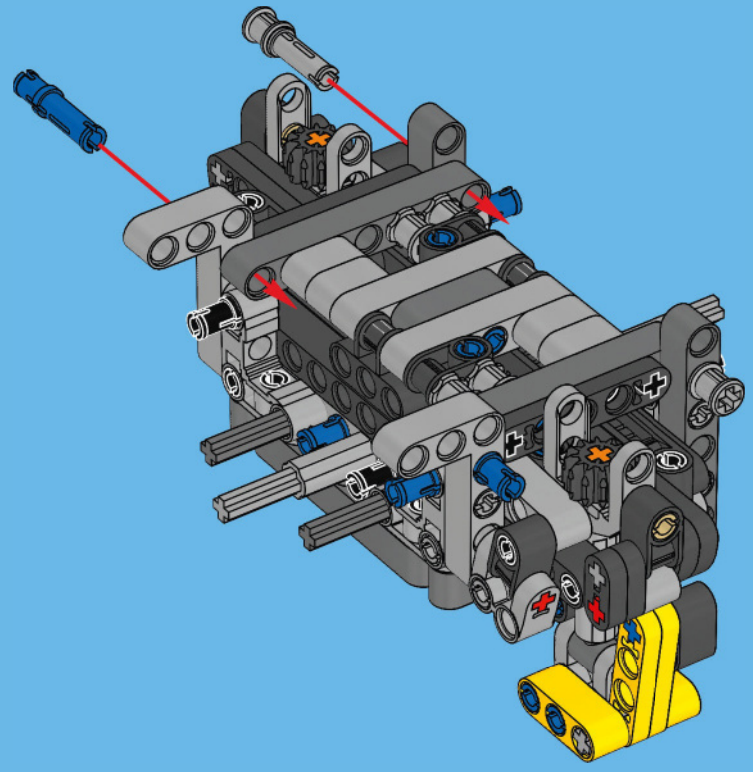
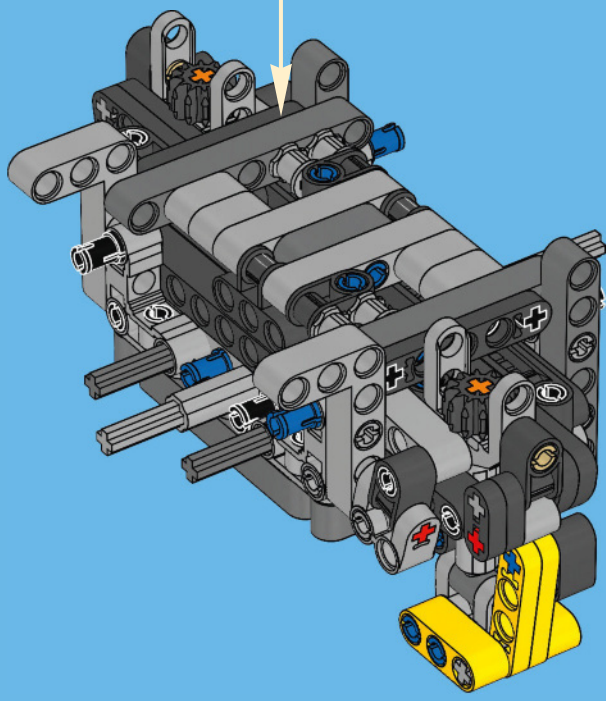



2x

# 26

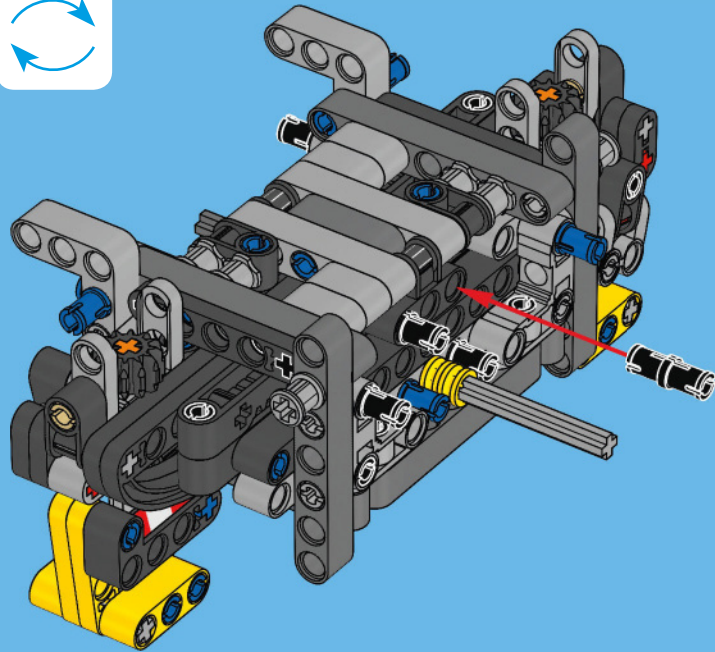

2x



1x

3



1x

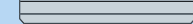

3

# 1:1

# 27

1

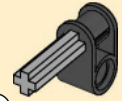

3

2

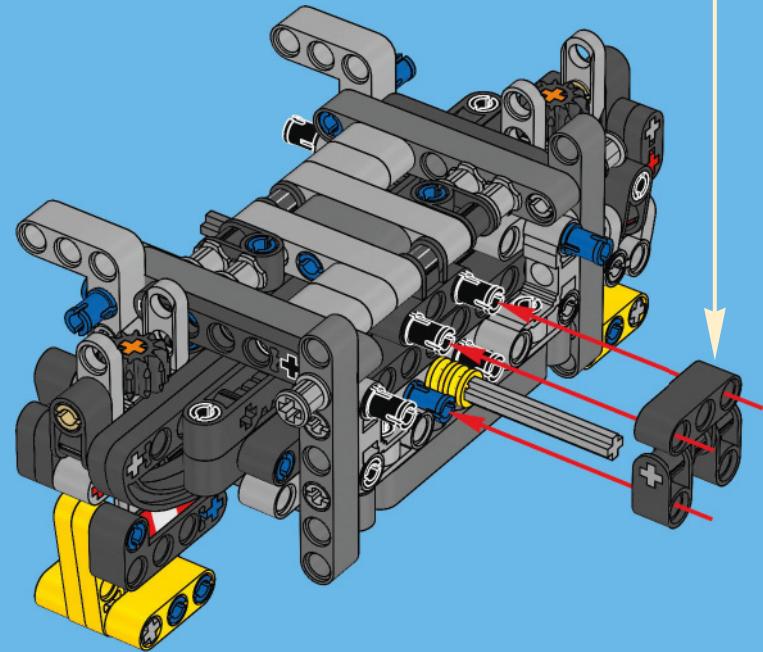
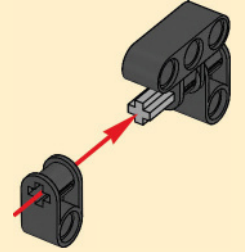





2x

# 28

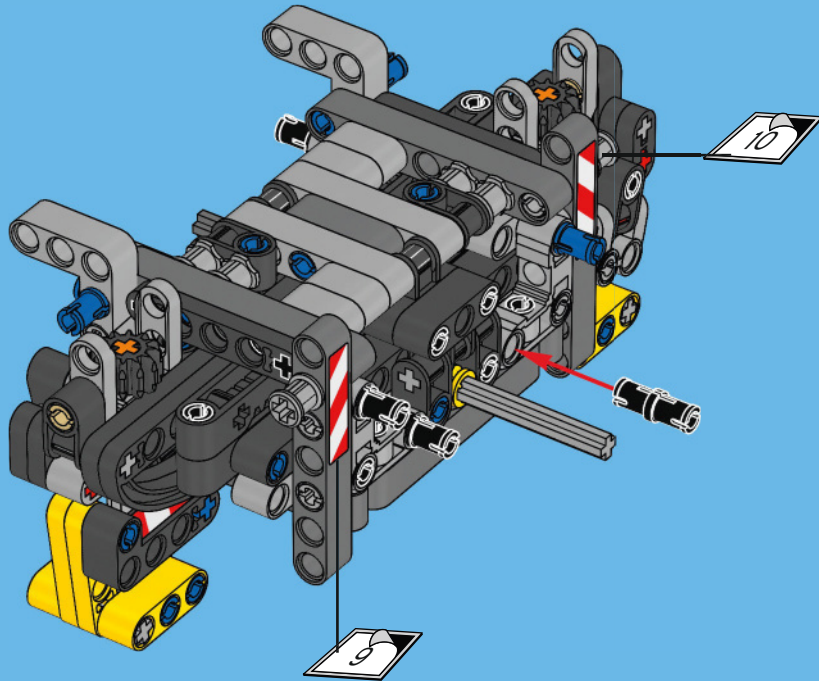

1x

# 29

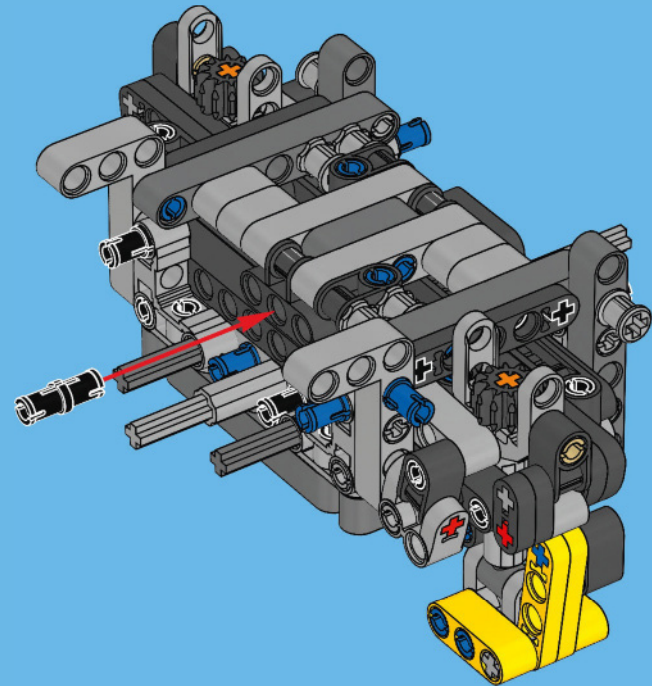

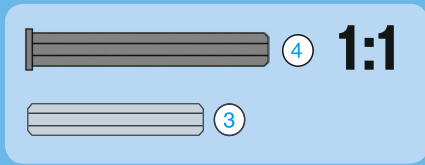
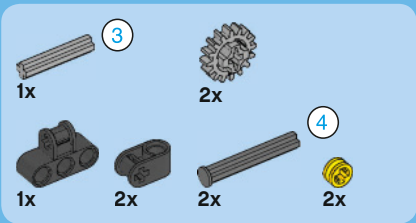

30

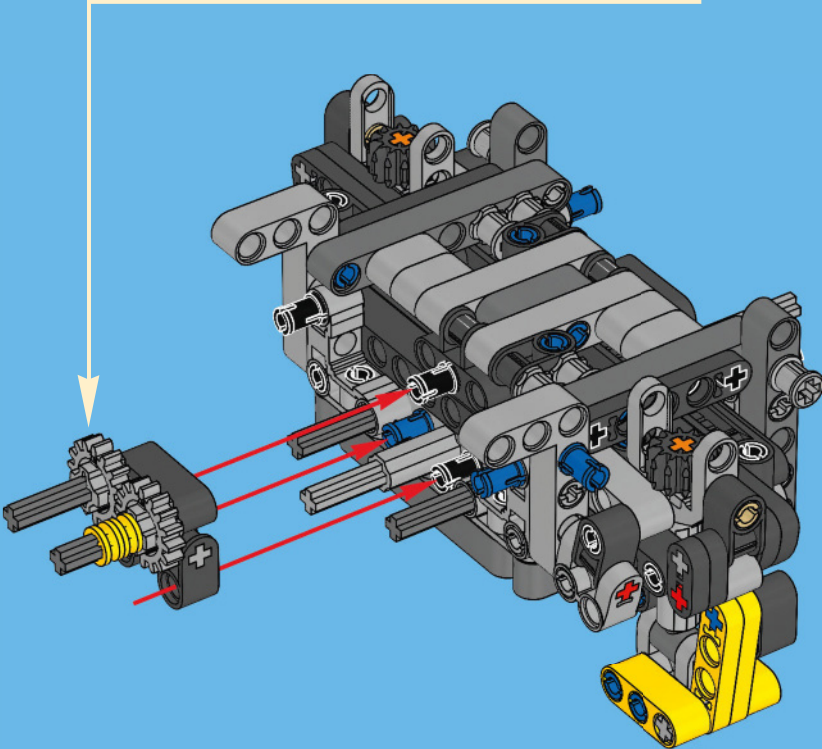
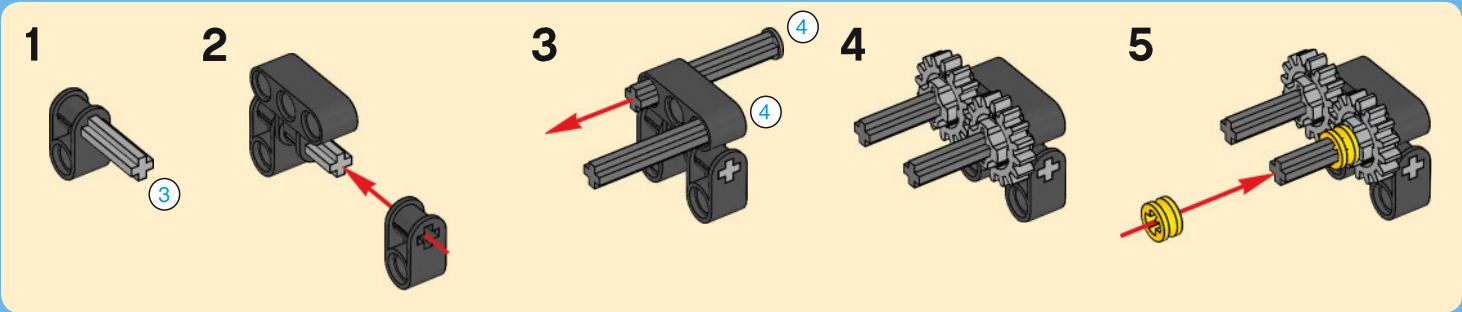

2x

2x

# 31

2x

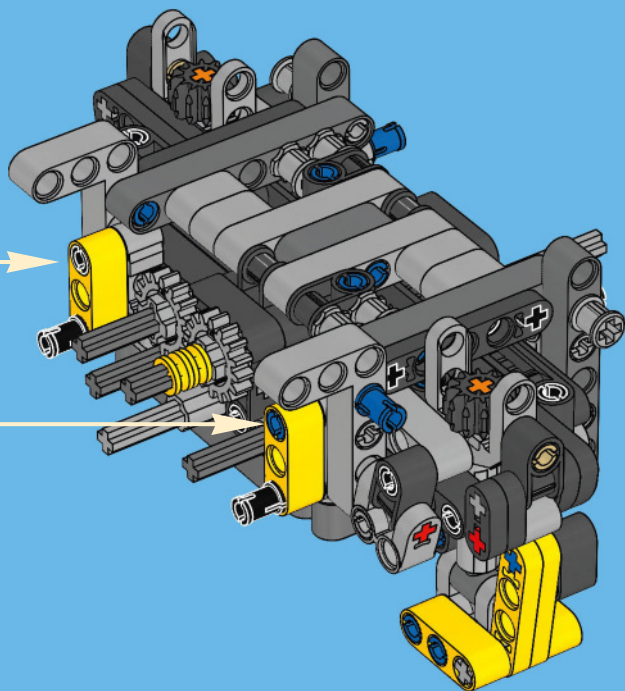

2x

# 32

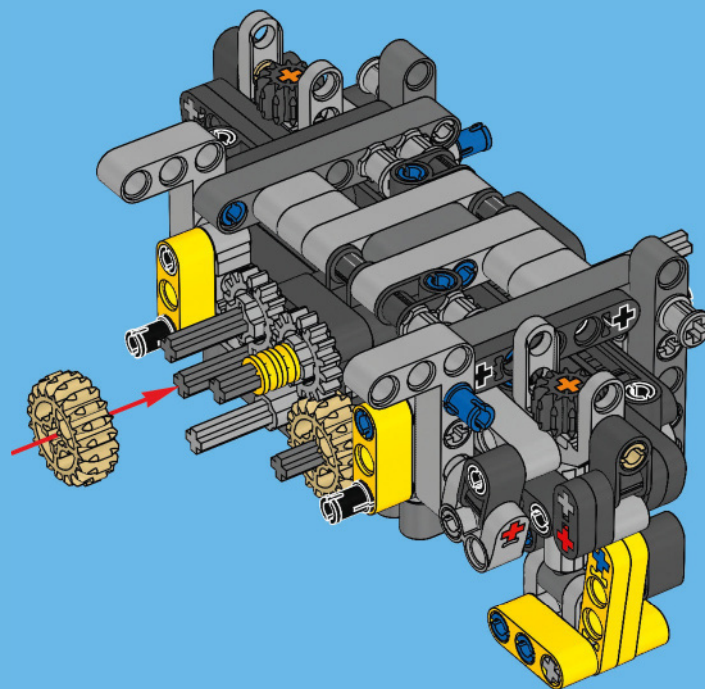



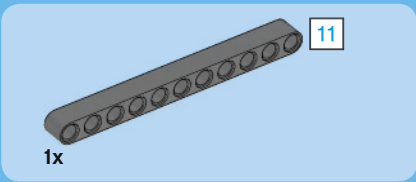

33

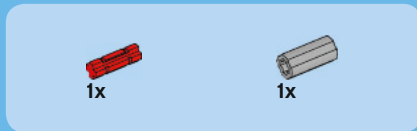
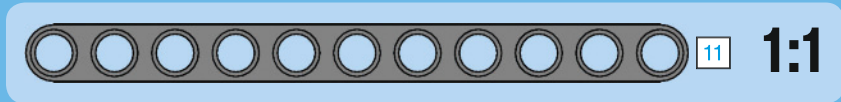
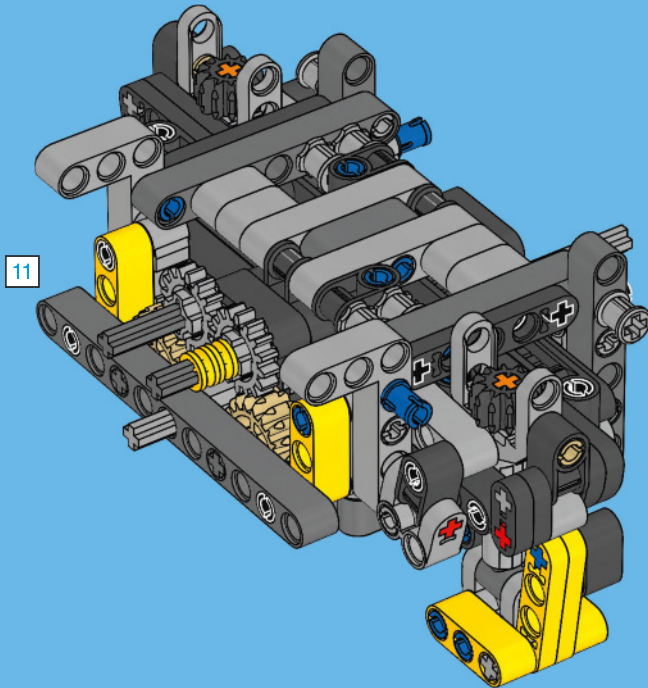

34

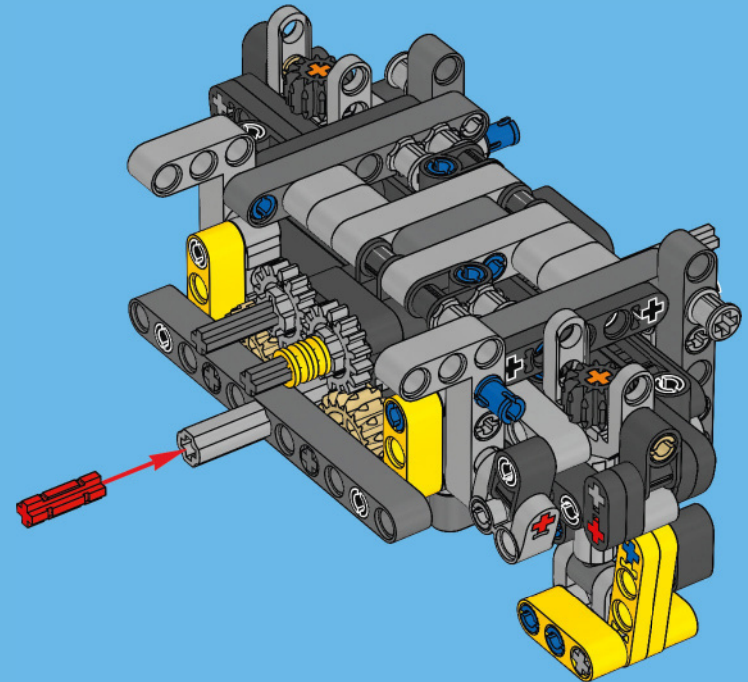



1x



1x



1x

# 35

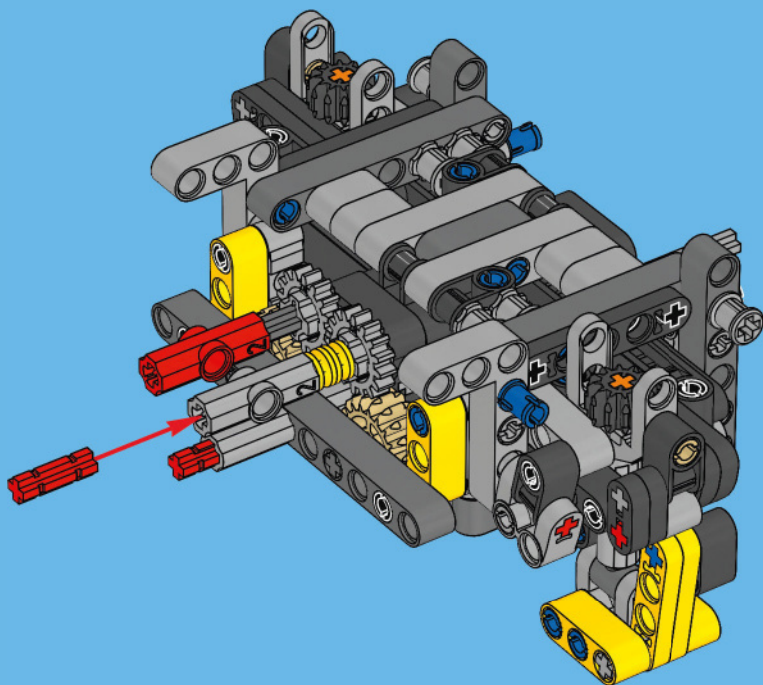

2x

# 36

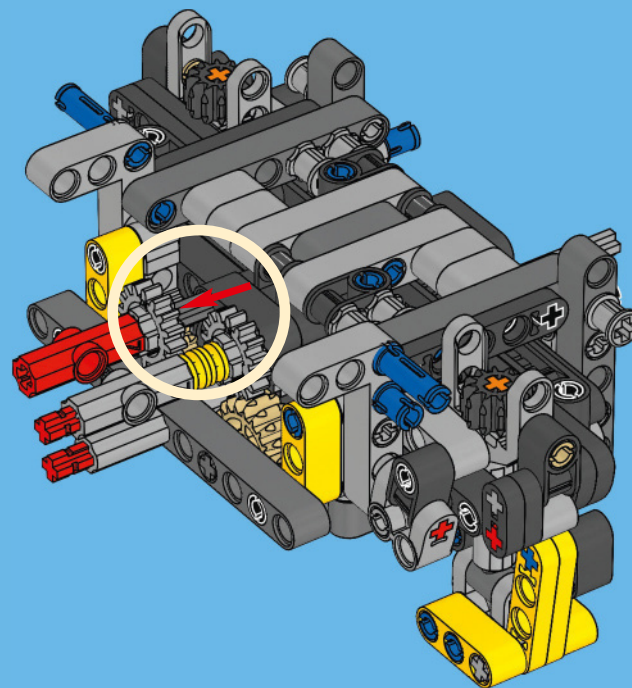

85

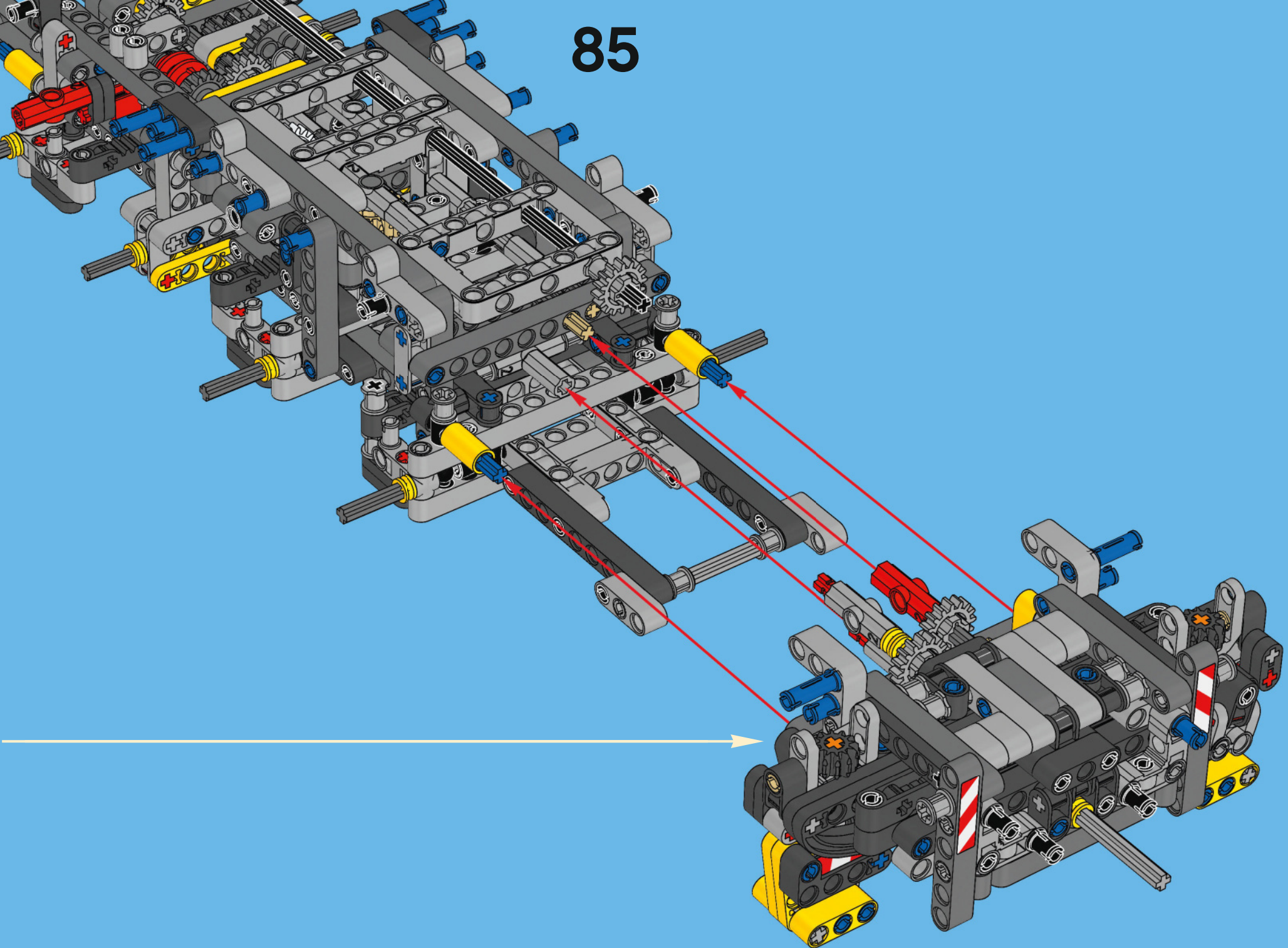





2x

# 86

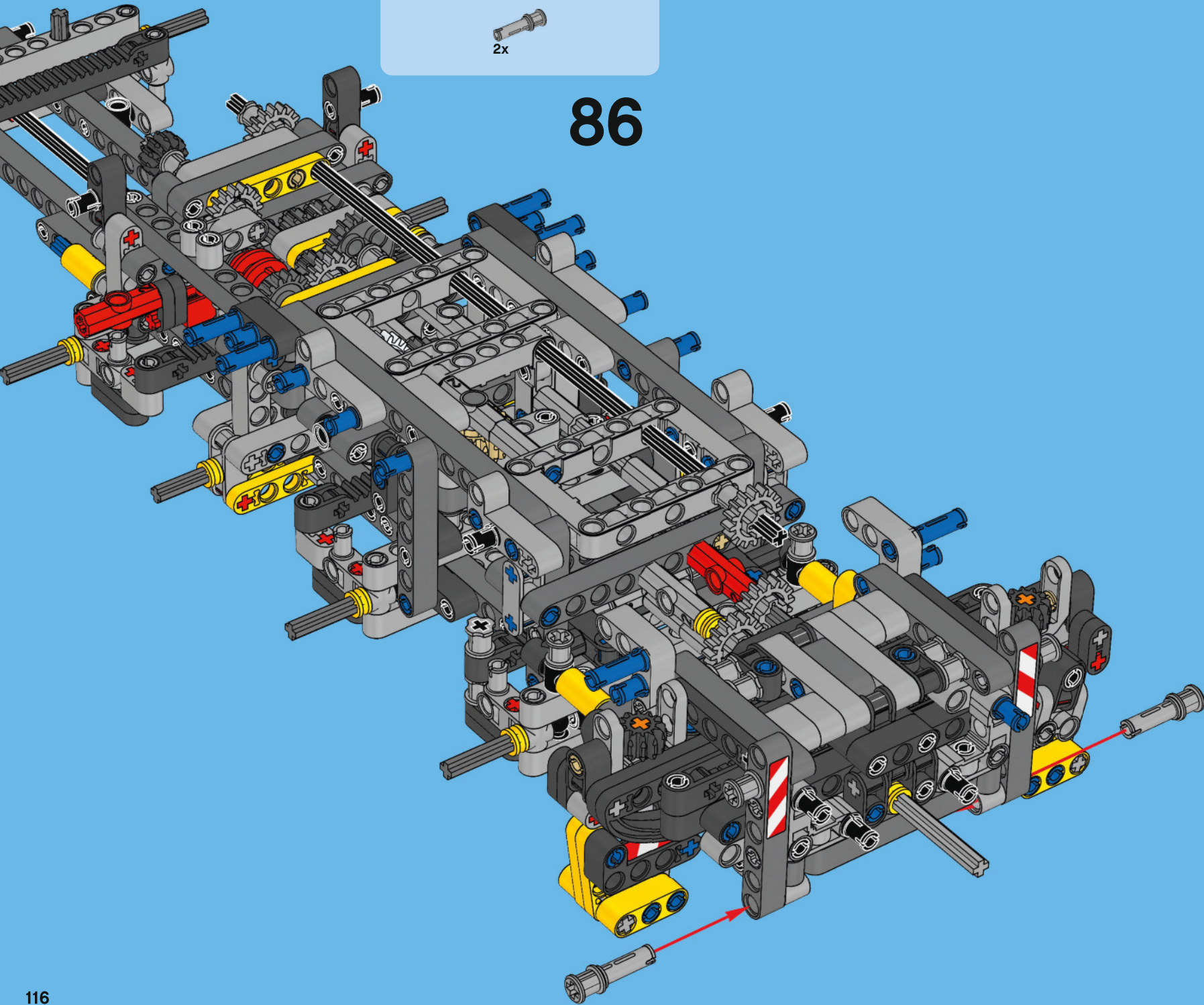

# 87

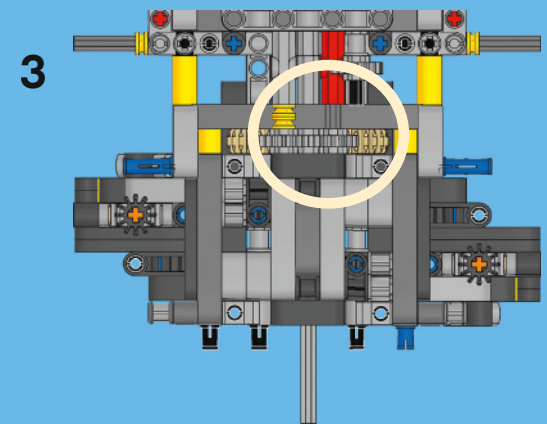
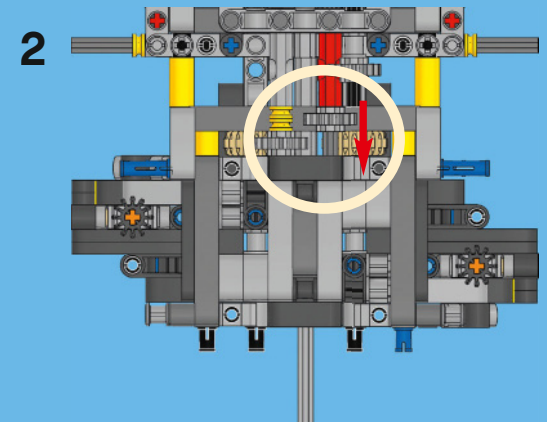
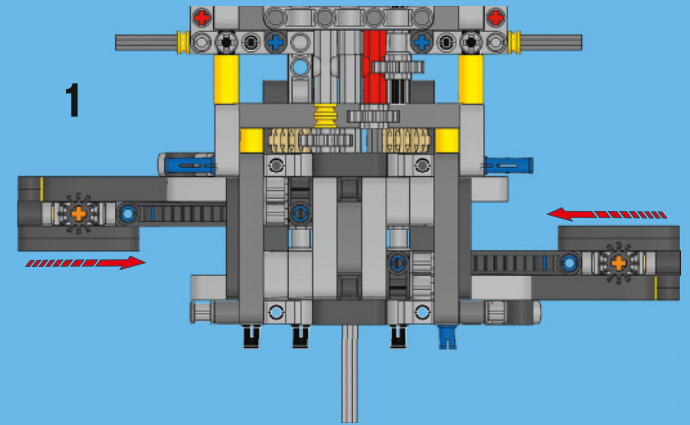
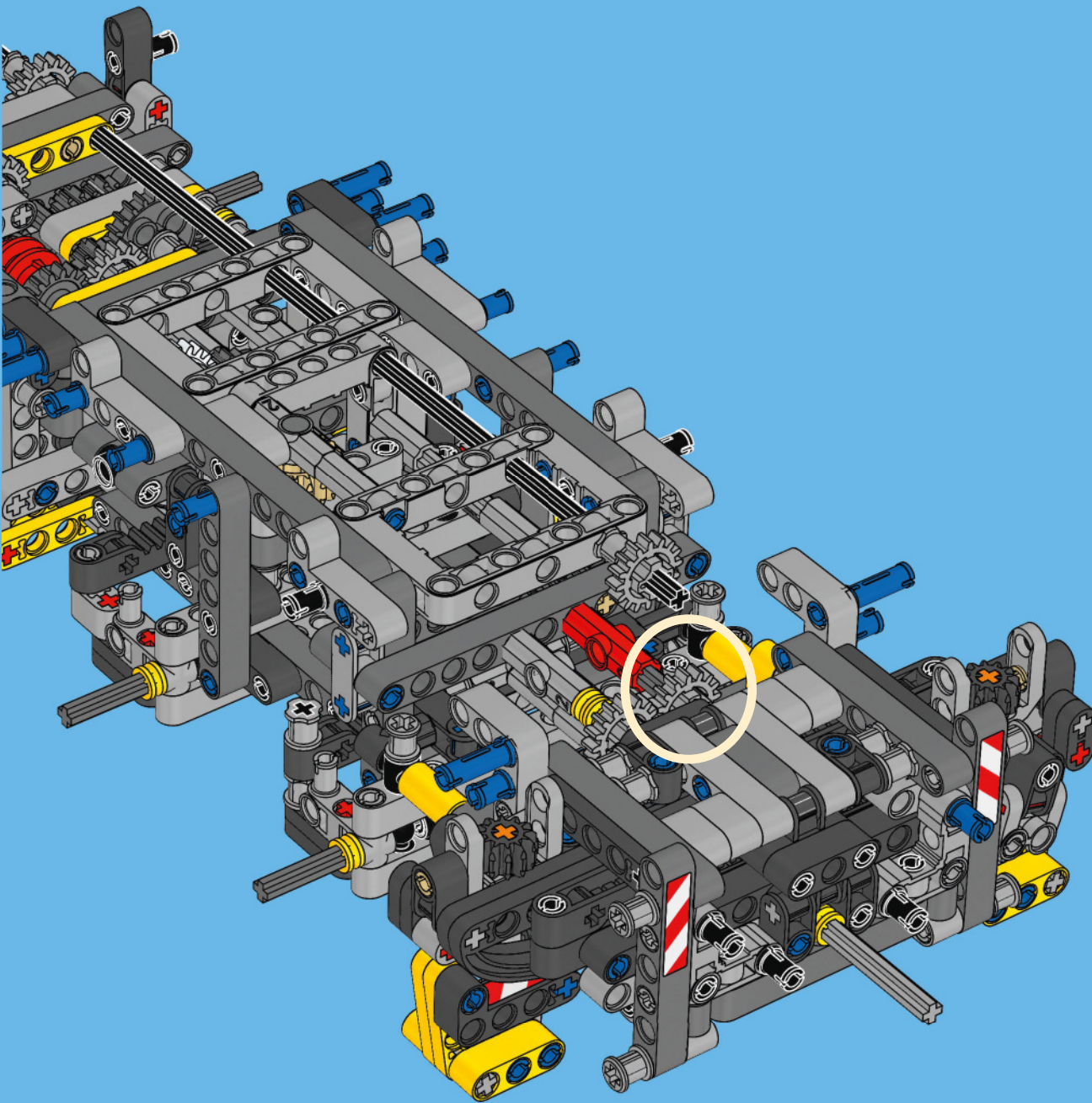



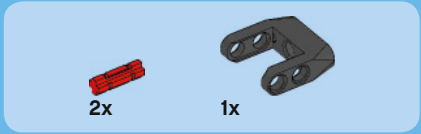
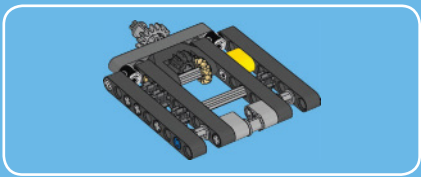

1

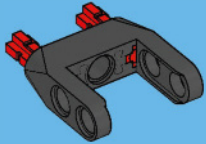

2

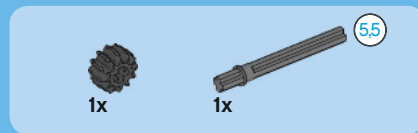
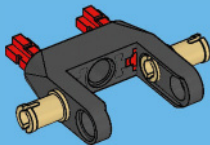

3

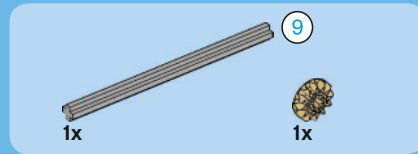
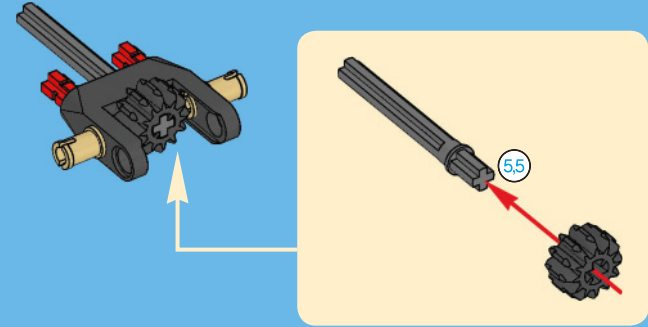
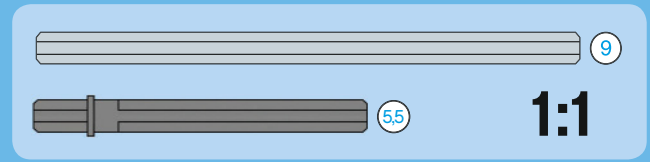

4

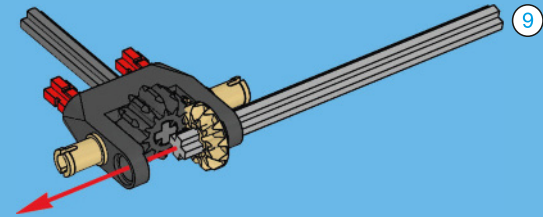



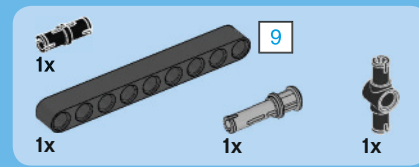
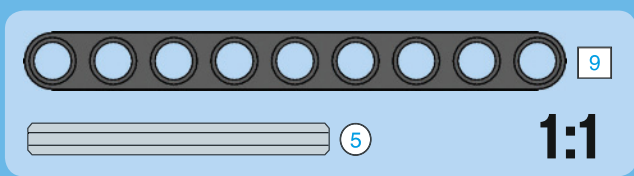
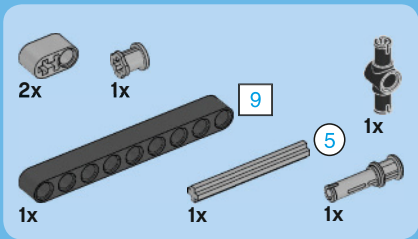

5

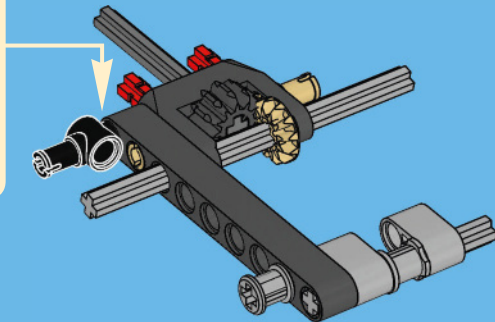
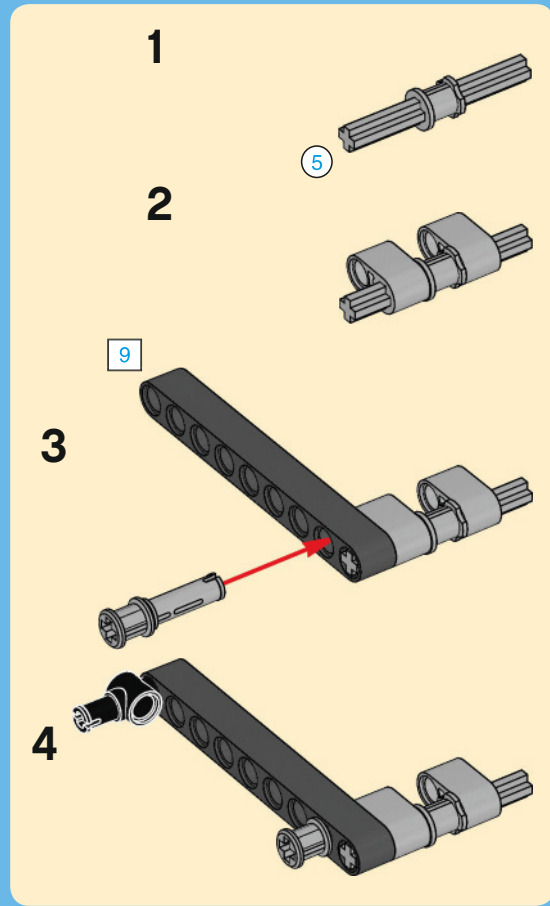

6

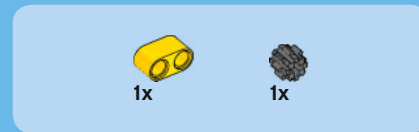
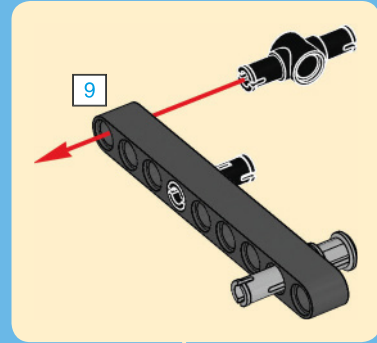

7

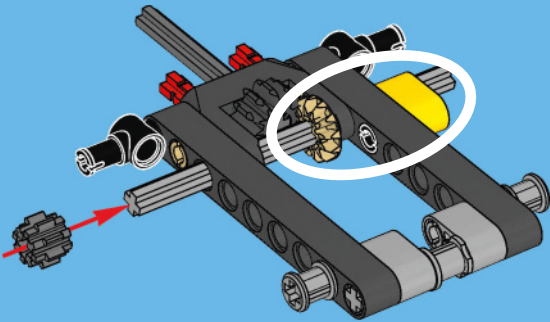

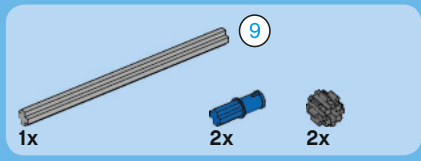

8

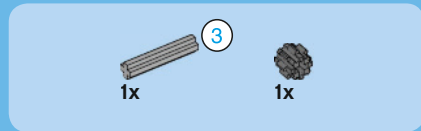
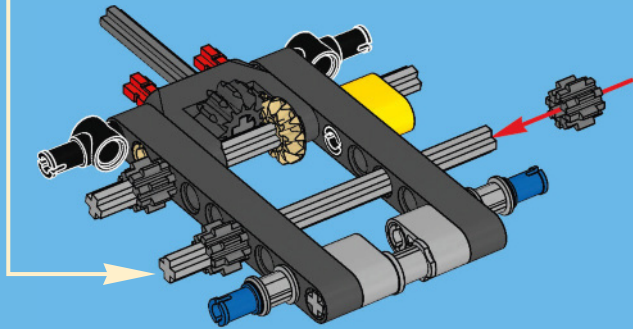
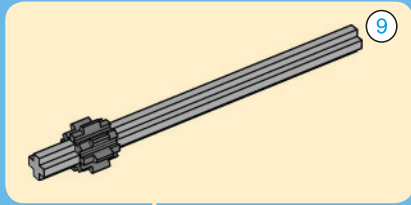
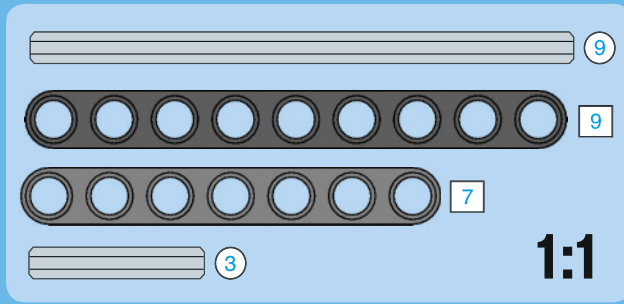

9

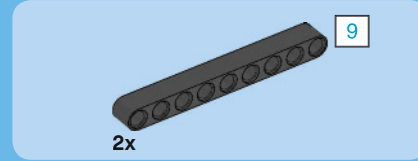
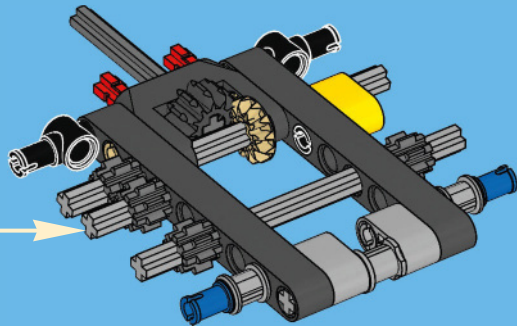
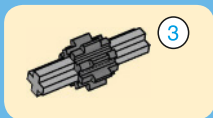

10

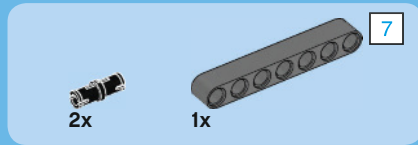
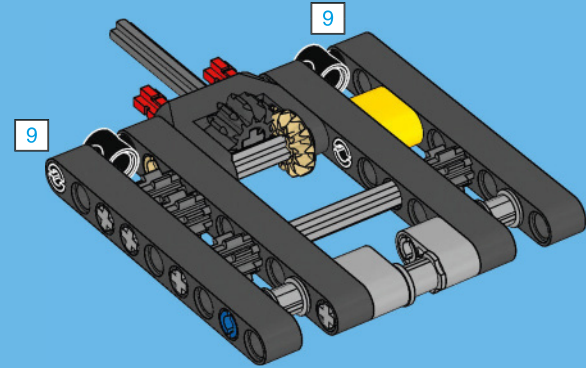

11

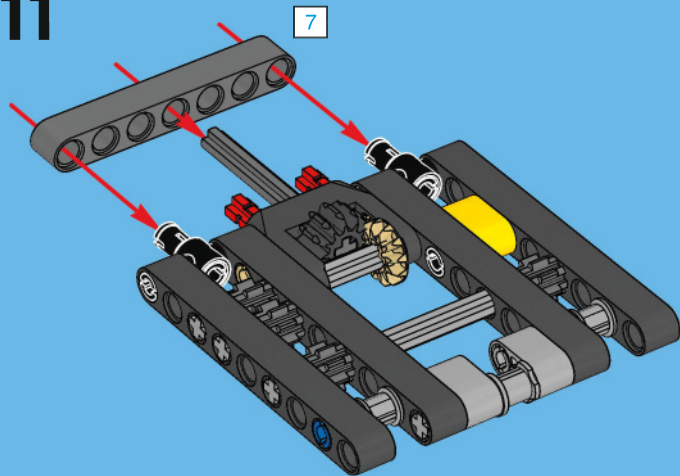



1x



1x

12

88

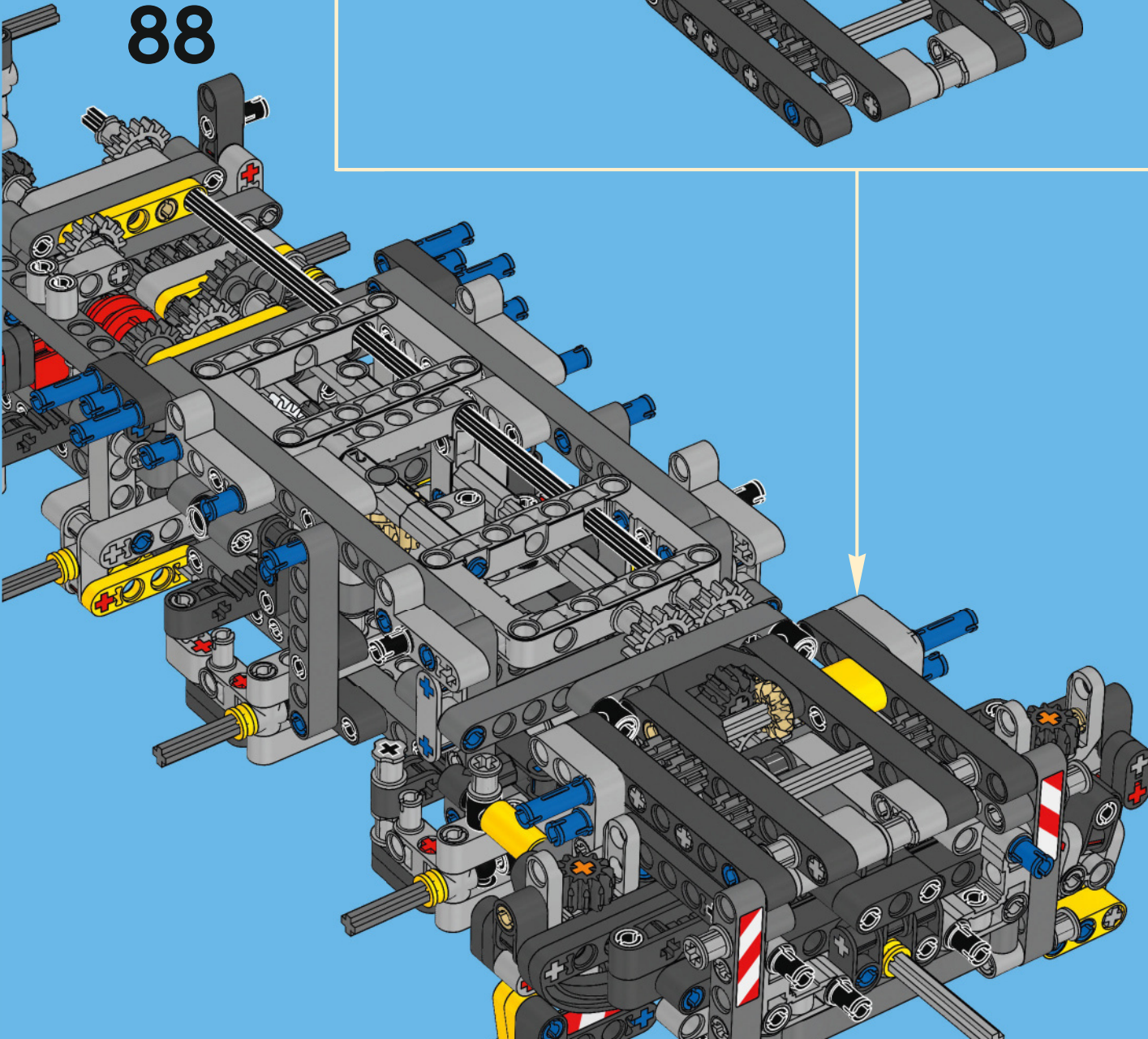
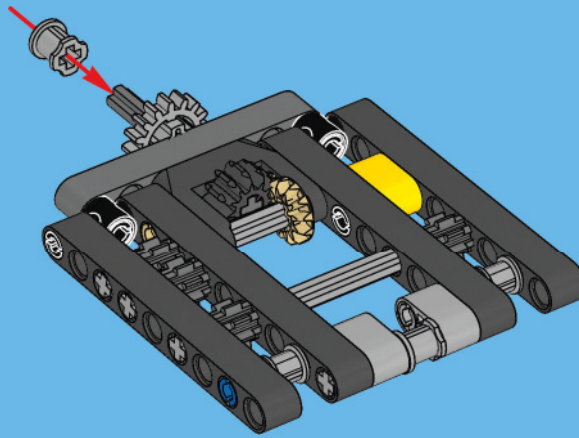





2x



2x

89

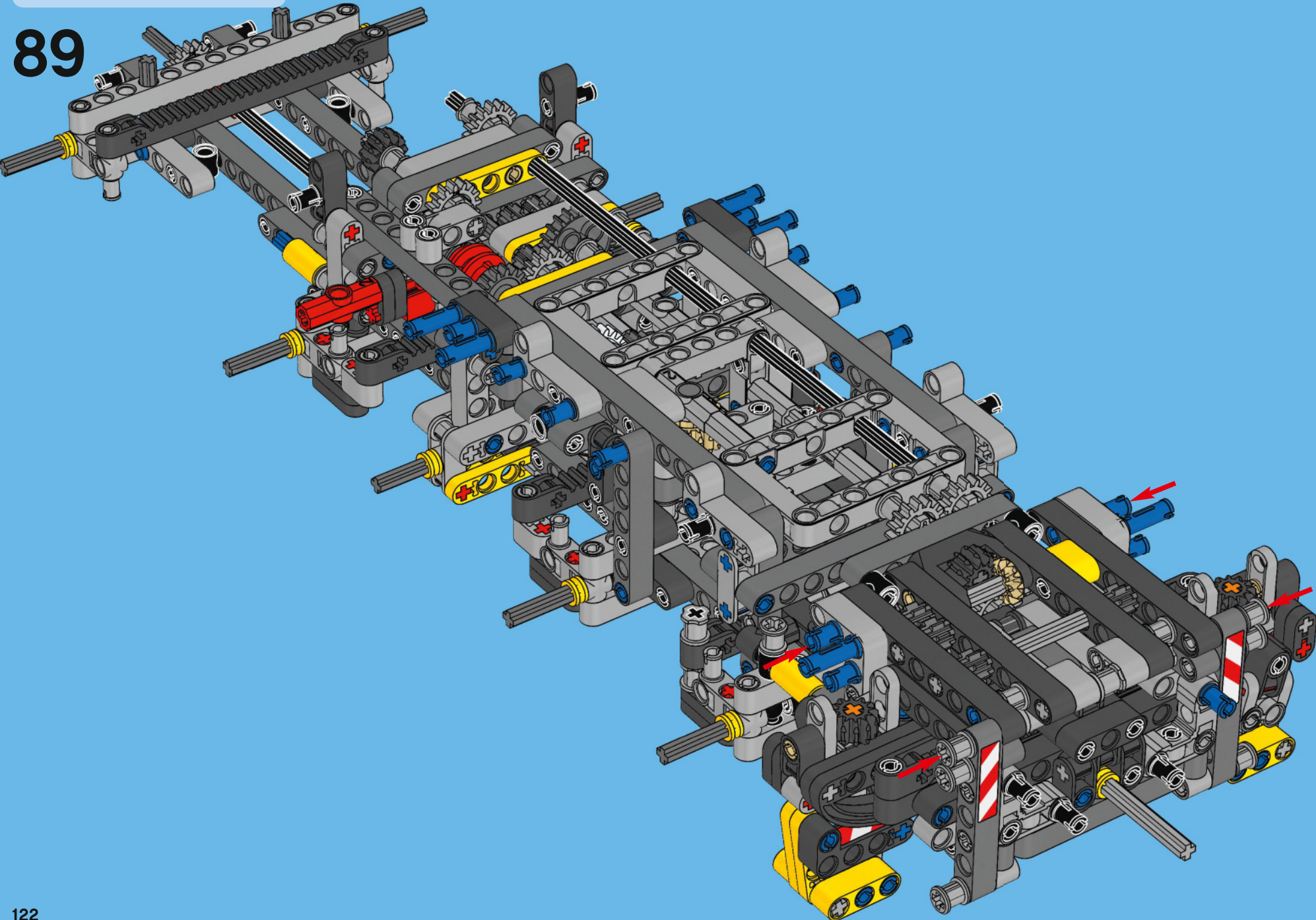

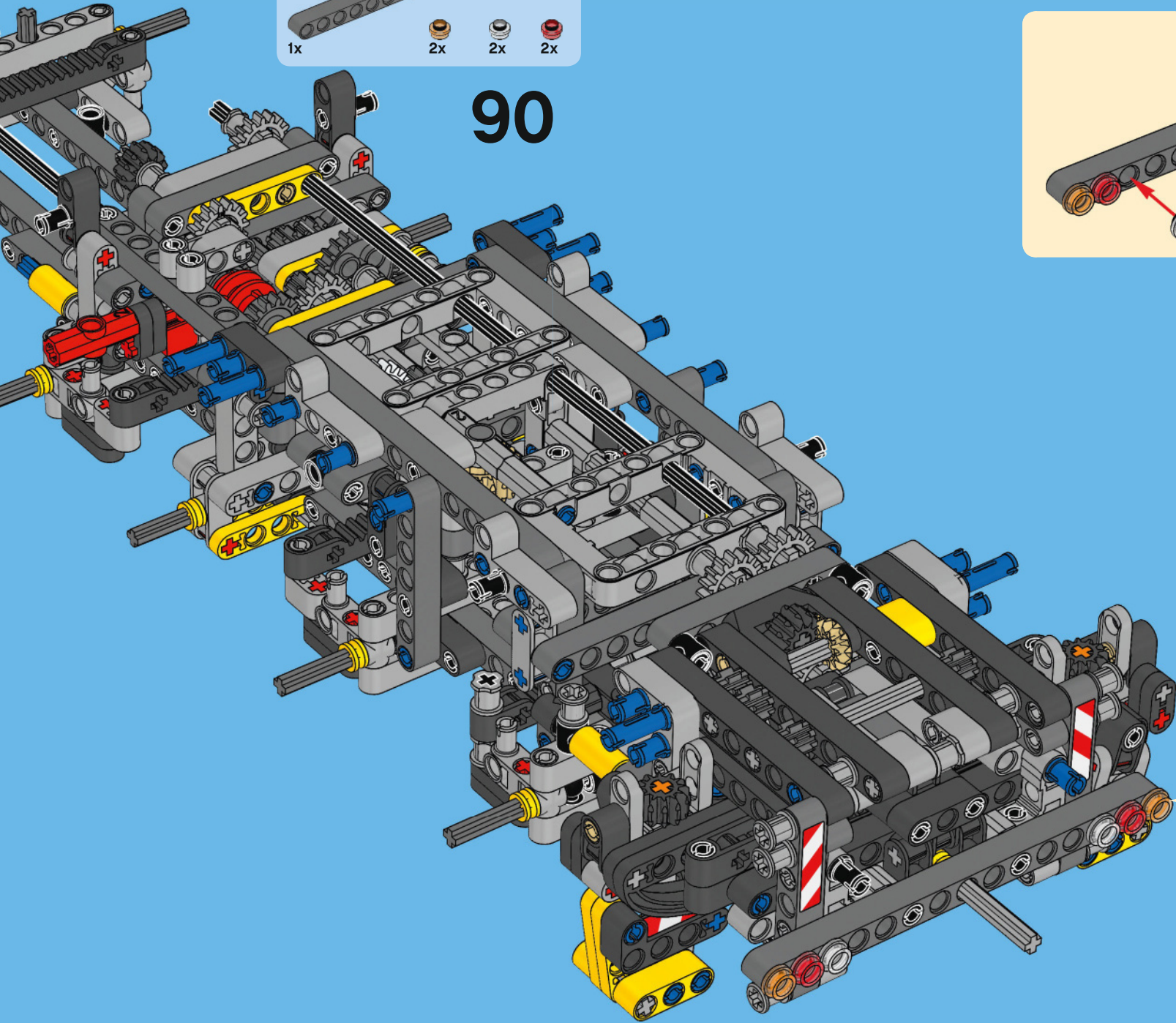

15

1x

2x

2x

2x

A parts list for step 15. It shows a grey Technic axle of length 15 with a small square hole at one end. Below the axle, there are three small circular components: a tan bush, a grey bush, and a red bush. Each bush is accompanied by a quantity: '2x' for the tan bush, '2x' for the grey bush, and '2x' for the red bush.

15 1:1

A reference image for step 15 showing a grey Technic axle of length 15 with a small square hole at one end. The number '15' and the ratio '1:1' are printed to the right of the axle.

15

A close-up view of the assembly process for step 15. It shows a grey Technic axle of length 15 with a small square hole at one end. A red arrow points to the second hole from the end, where a grey bush is being inserted. The tan and red bushes are already inserted into the first and third holes from the end, respectively.





1x



1x

# 91

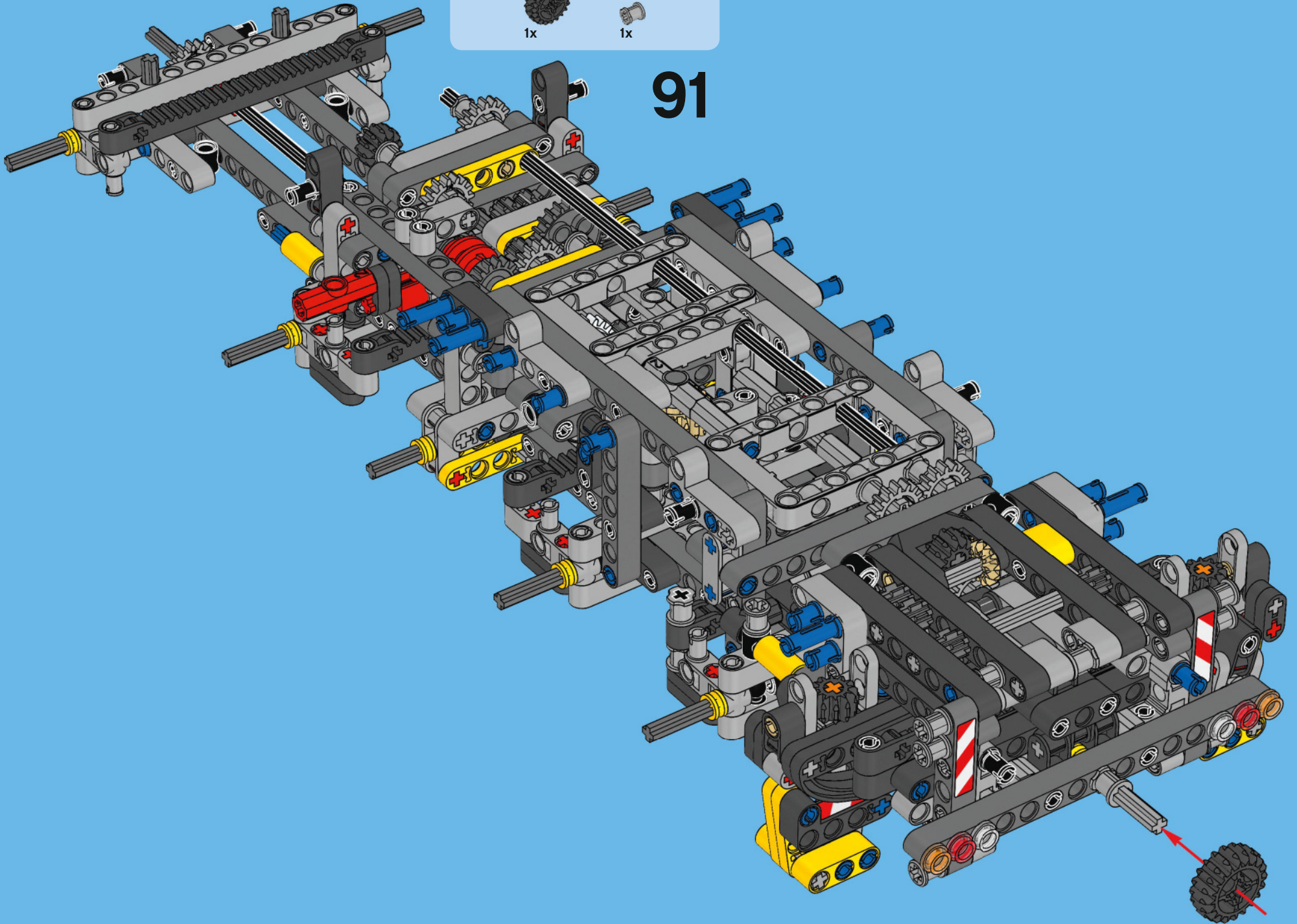



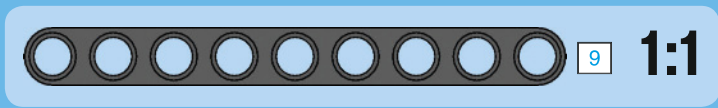
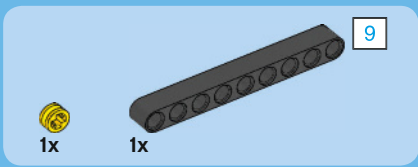

92

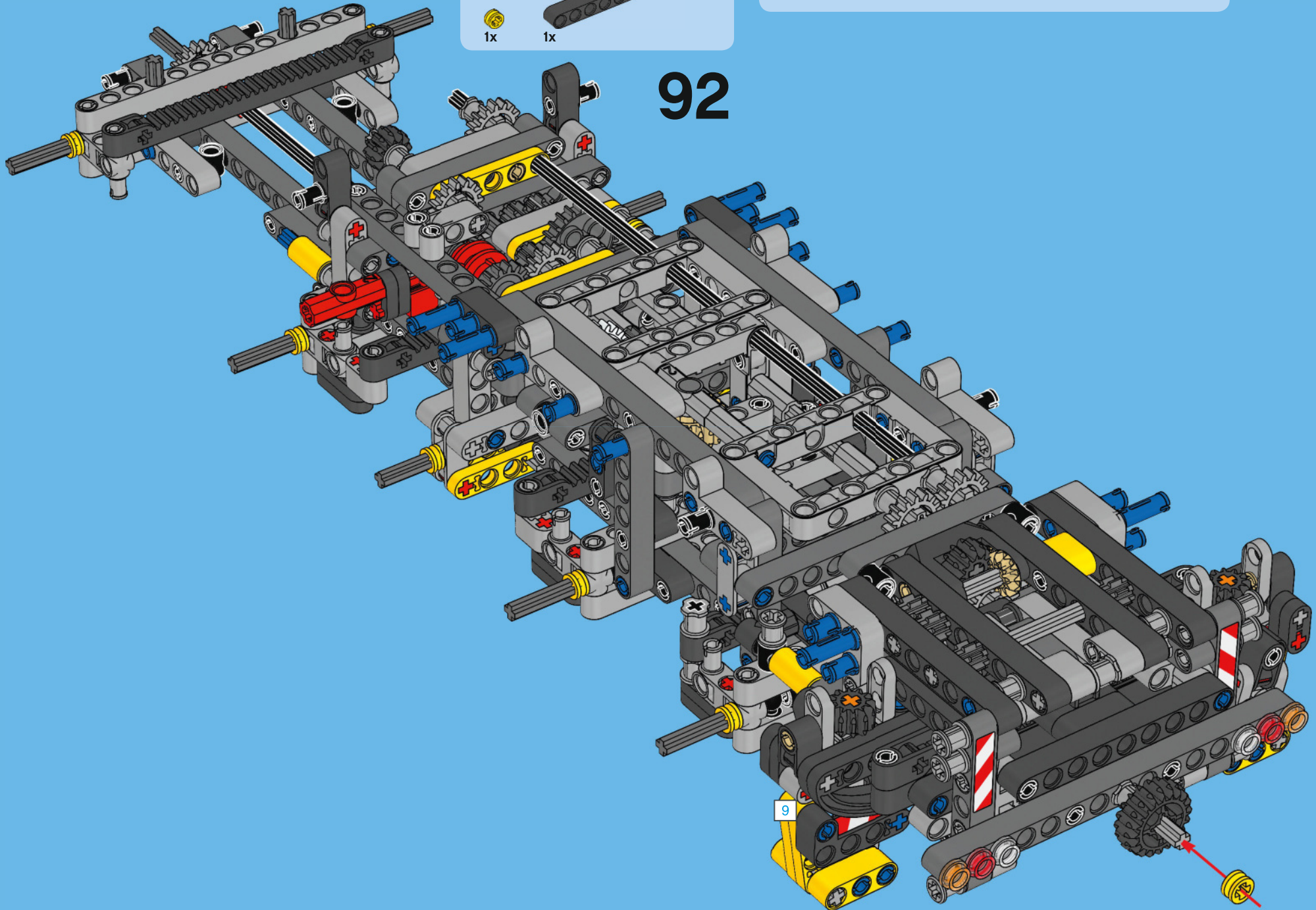

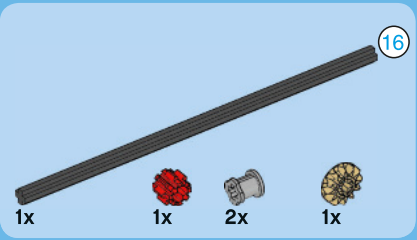

93

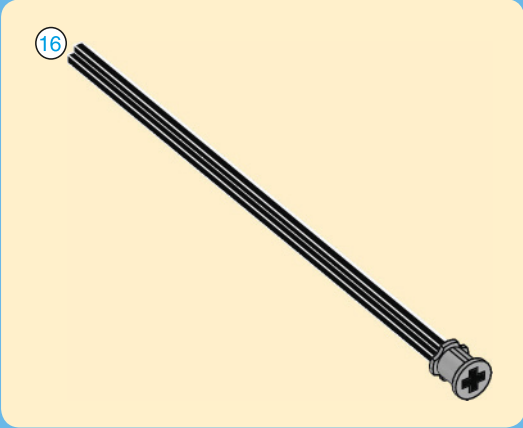
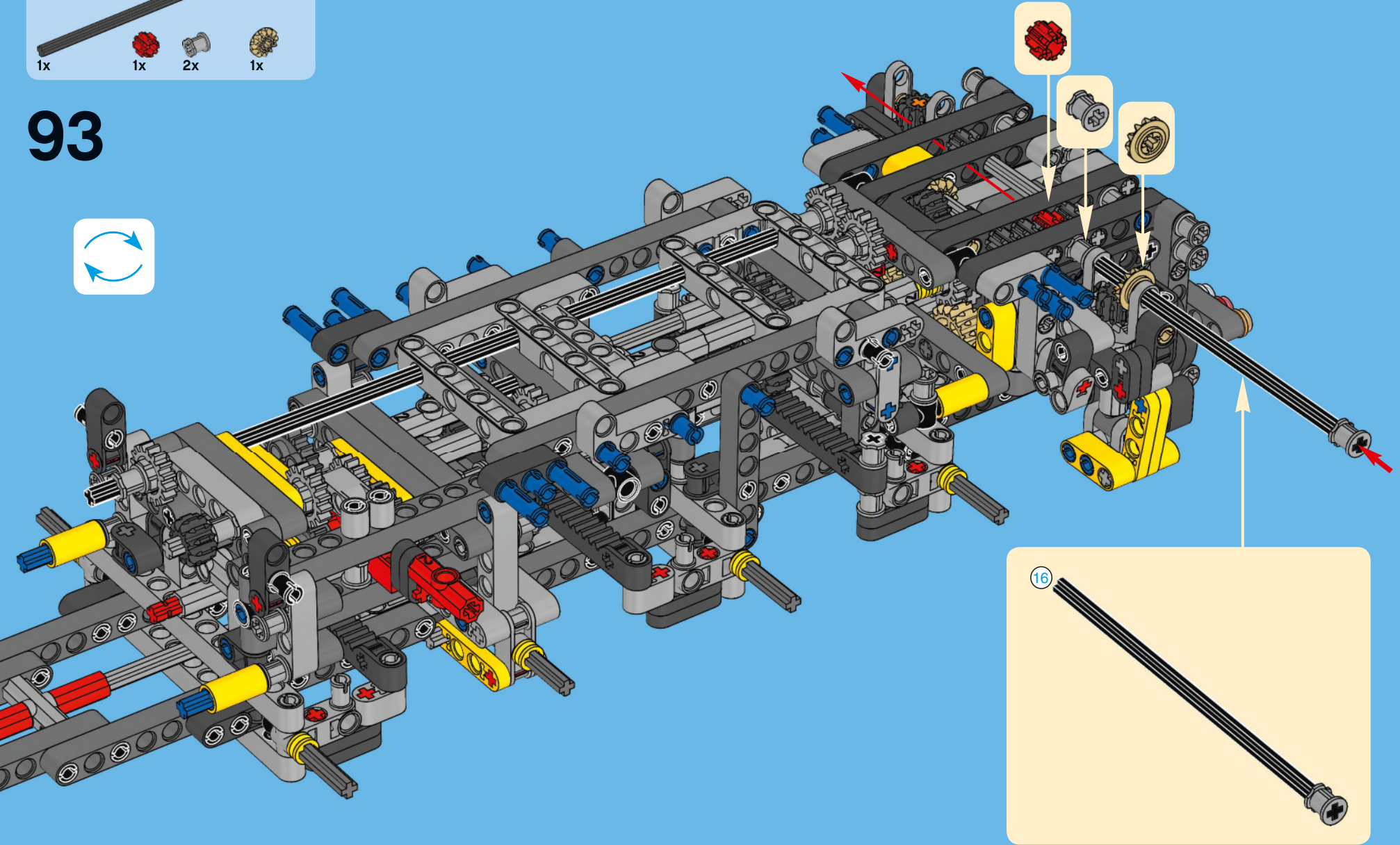



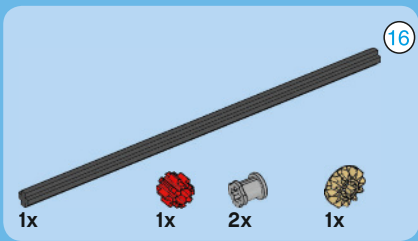

94

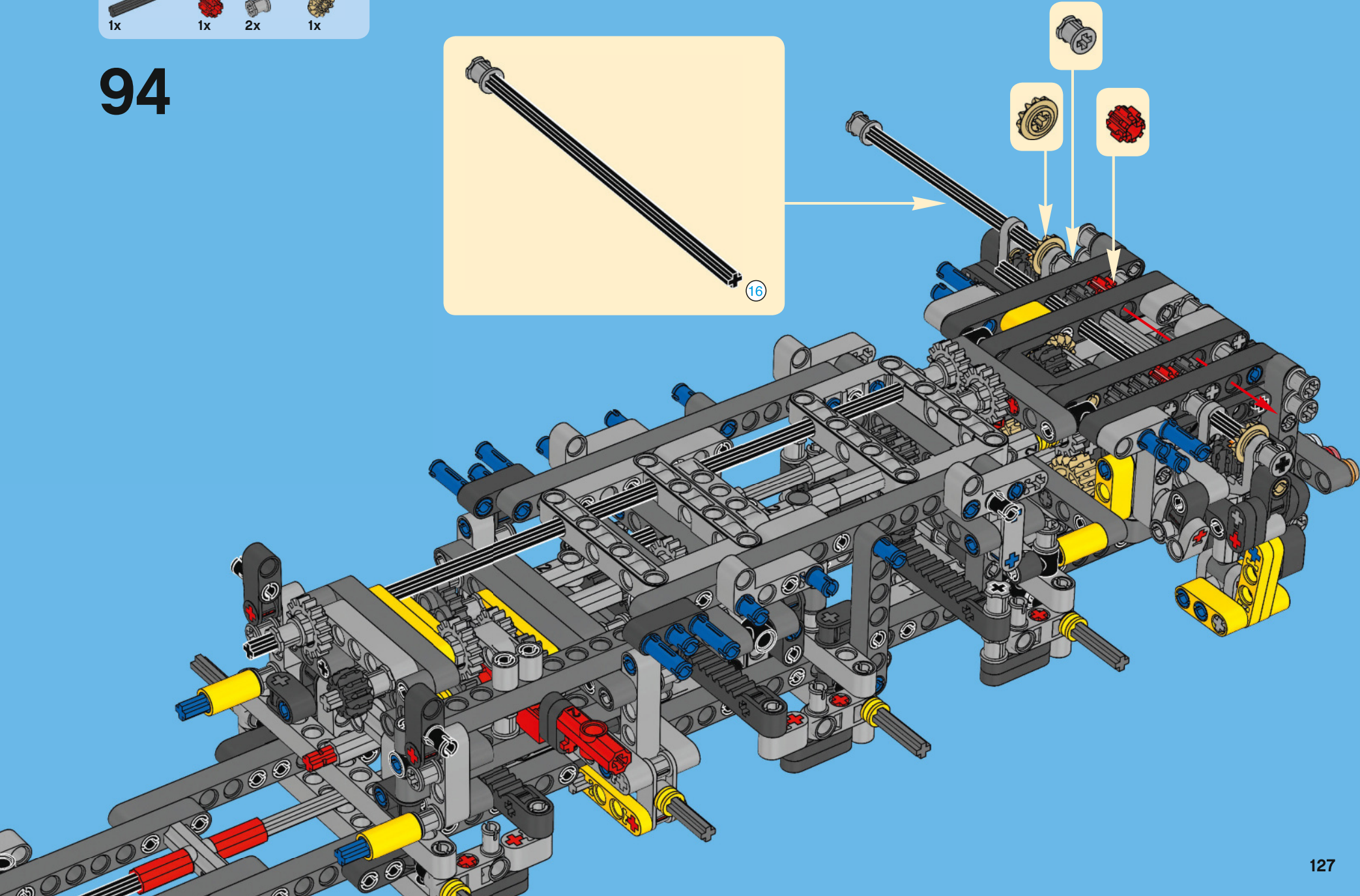
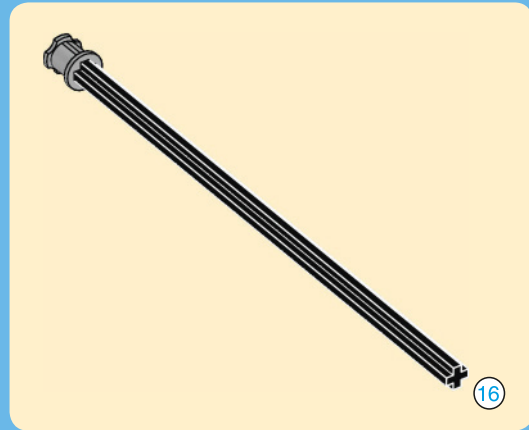



95

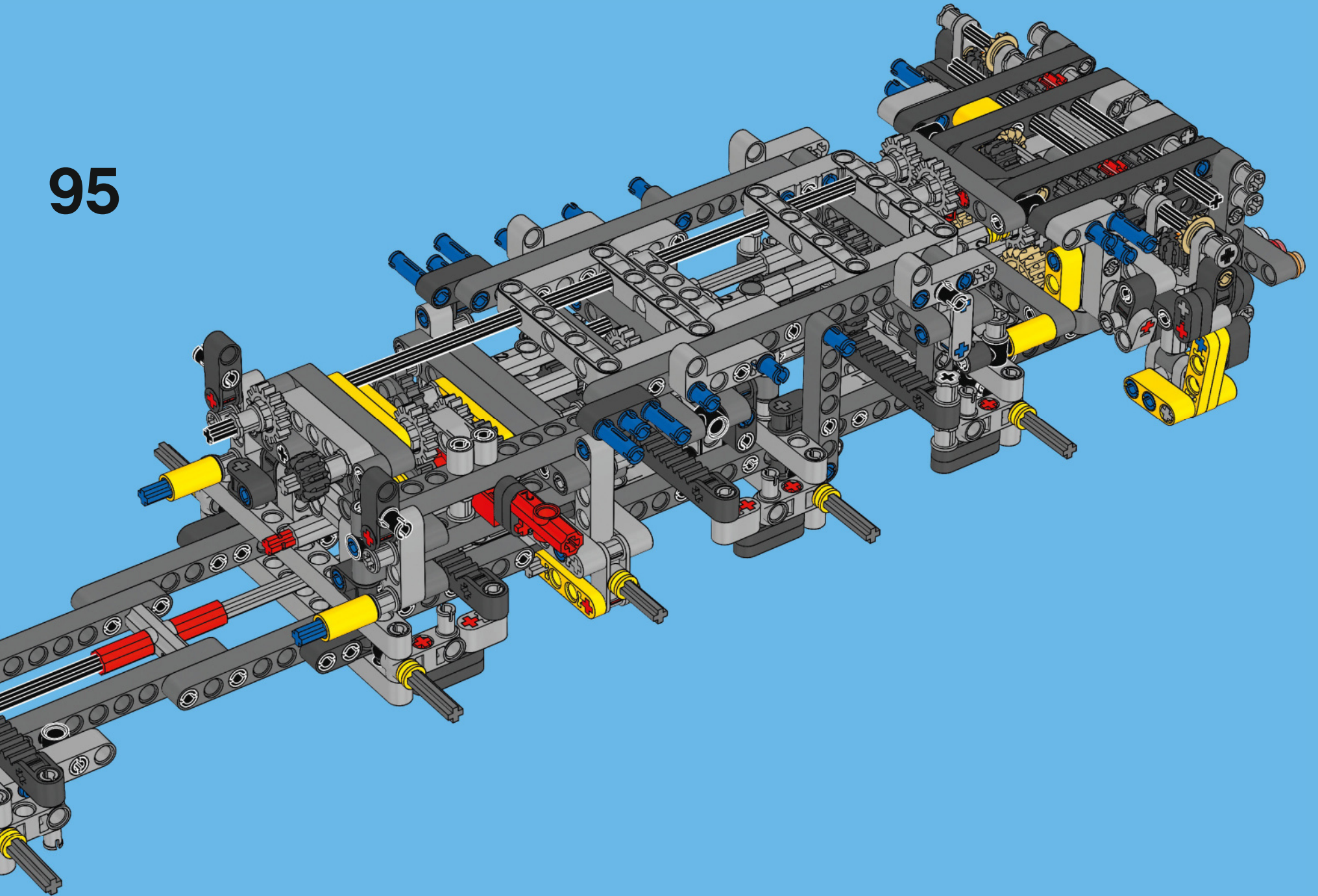

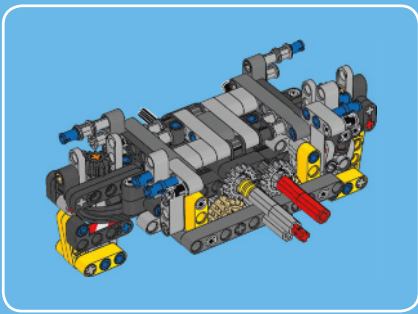

3

1:1

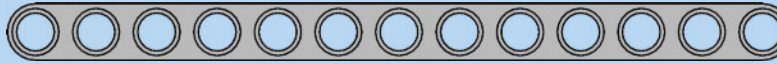

13

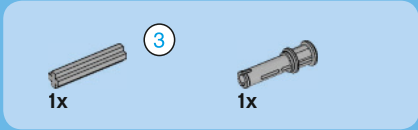

3

1x

1x

1

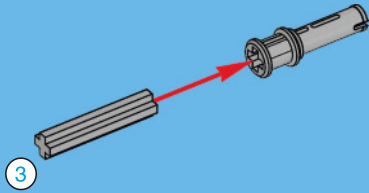

2x

2

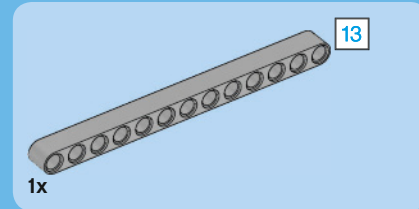
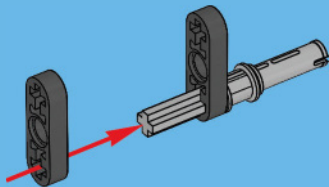

13

1x

3

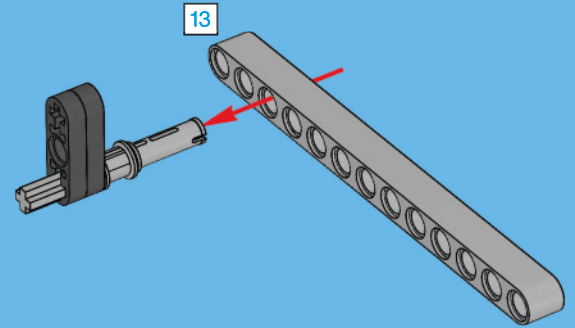

13



1x

3x

4

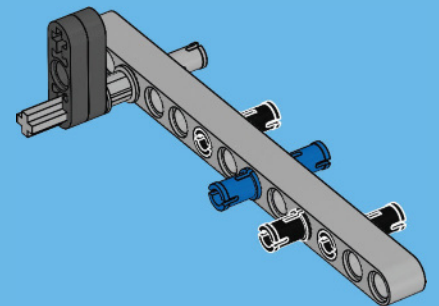

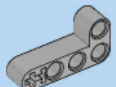

1x



8

1:1

5

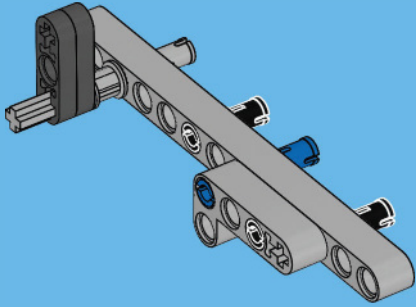

1x

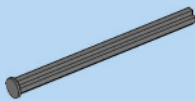

1x

8

6

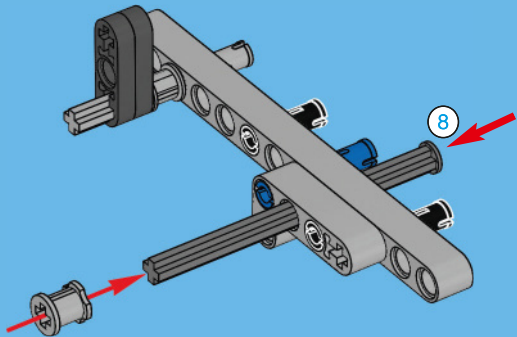

1x

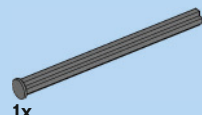

1x

8

7

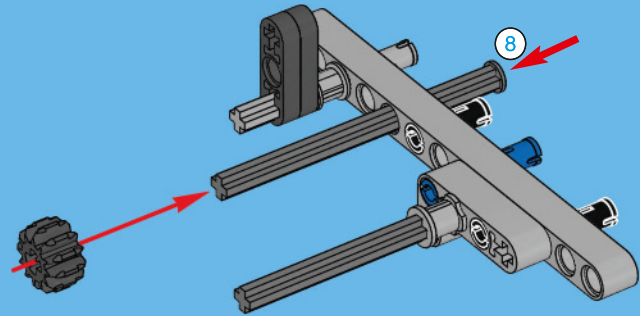

1x



1x

8

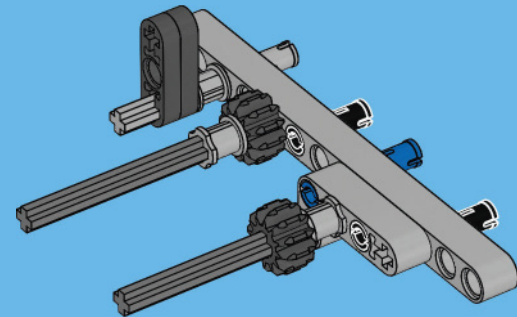



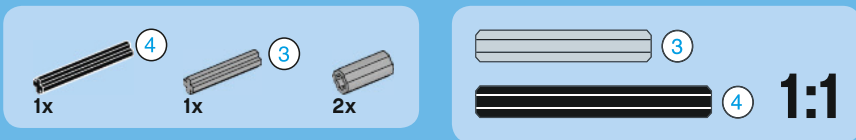

9

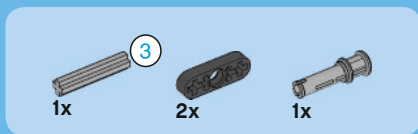
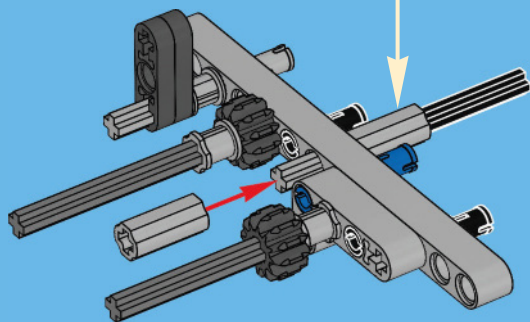
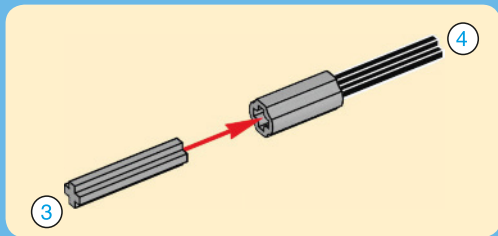

10

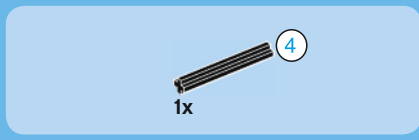
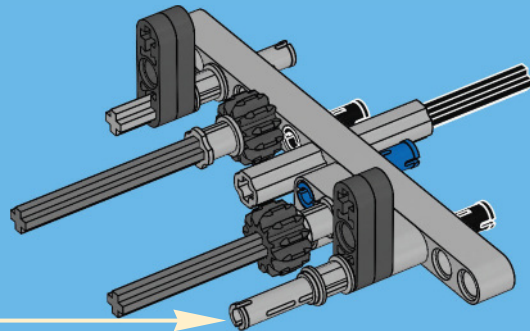
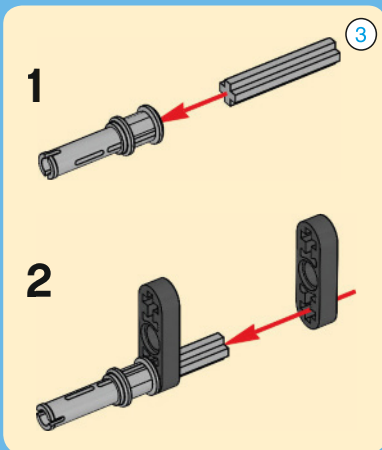

11

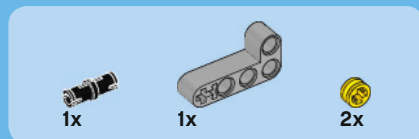
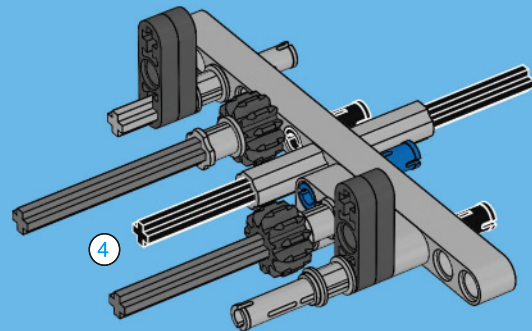

12

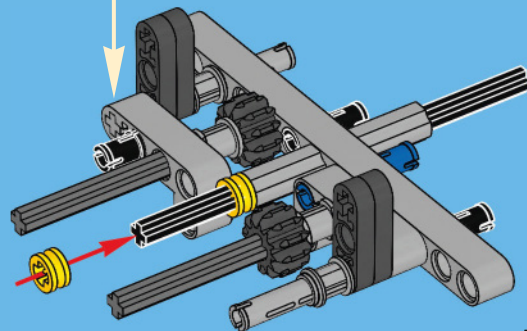
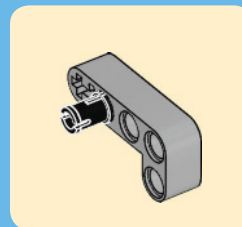

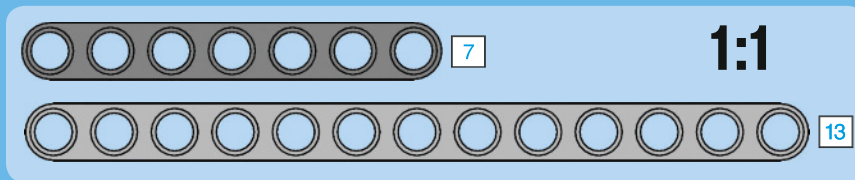
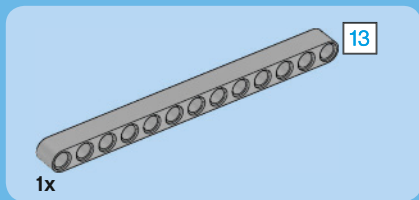

13

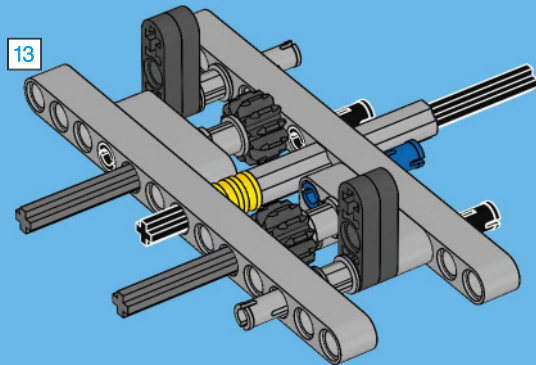

14

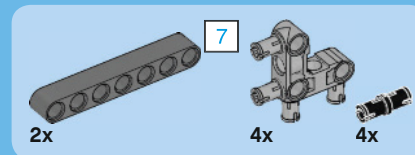
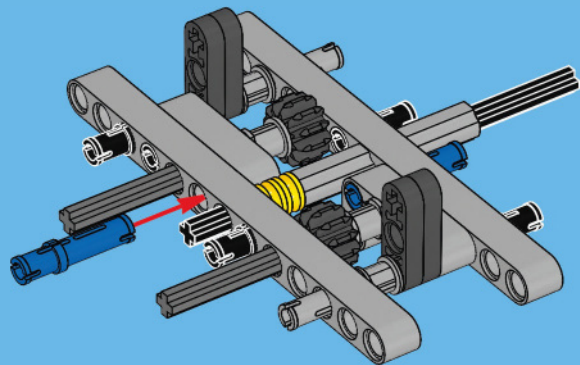

15

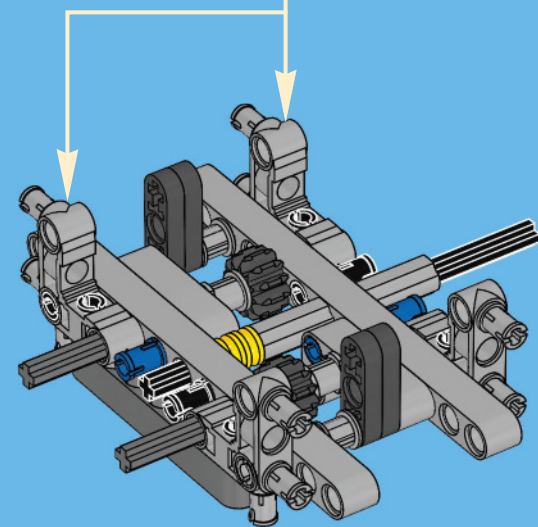
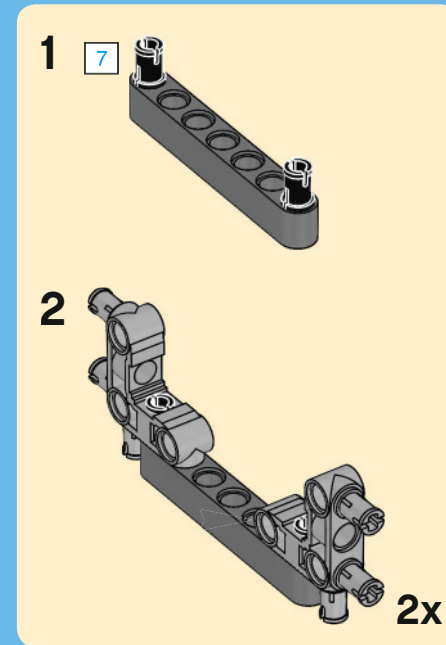

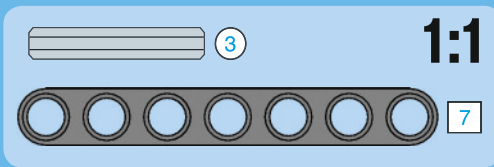
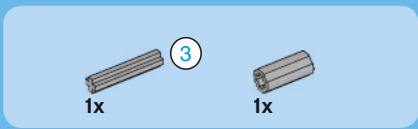

16

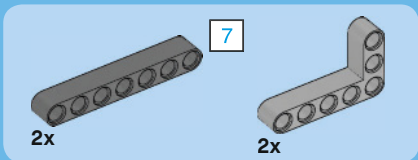
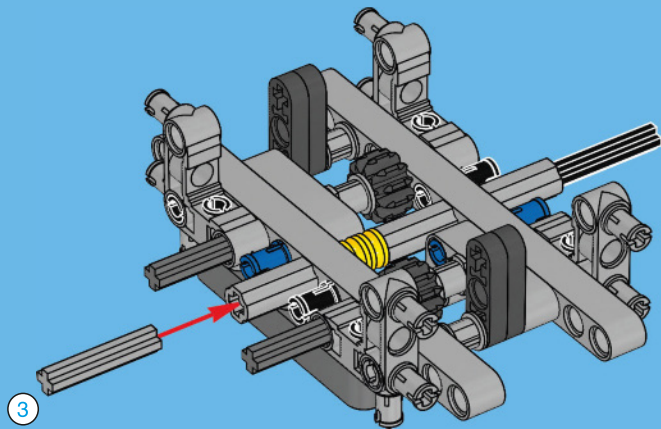

17

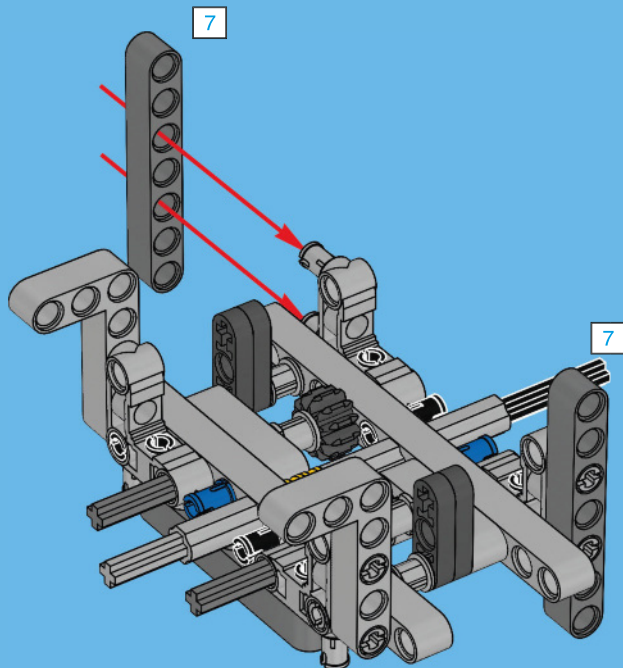

18

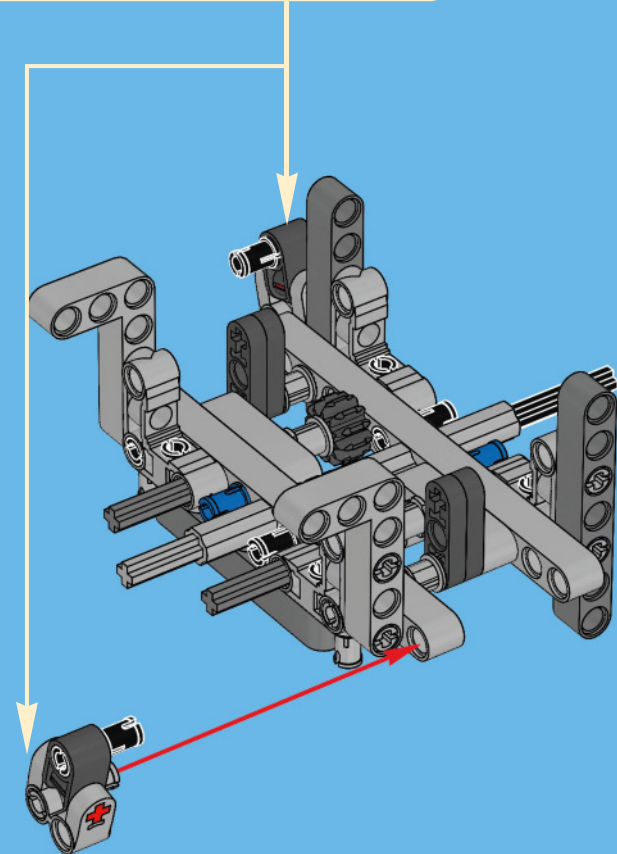
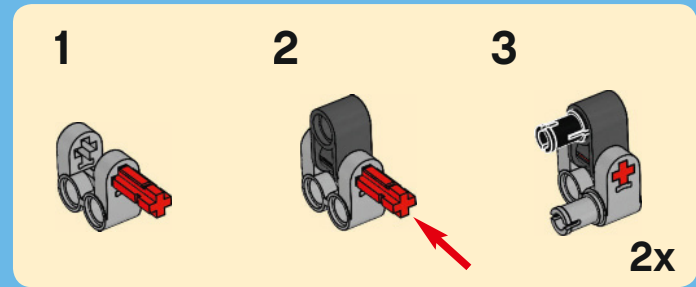



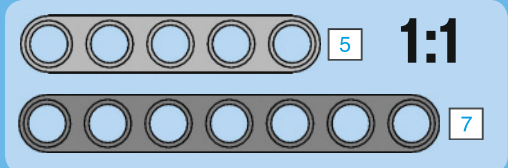
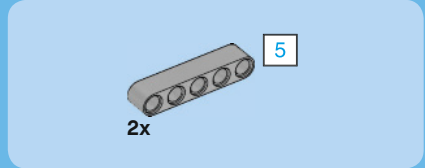

19

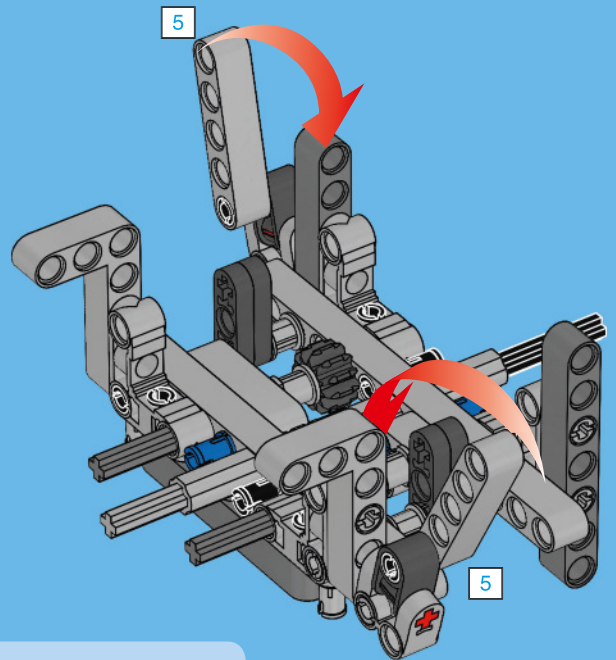

20

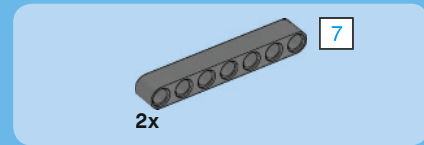
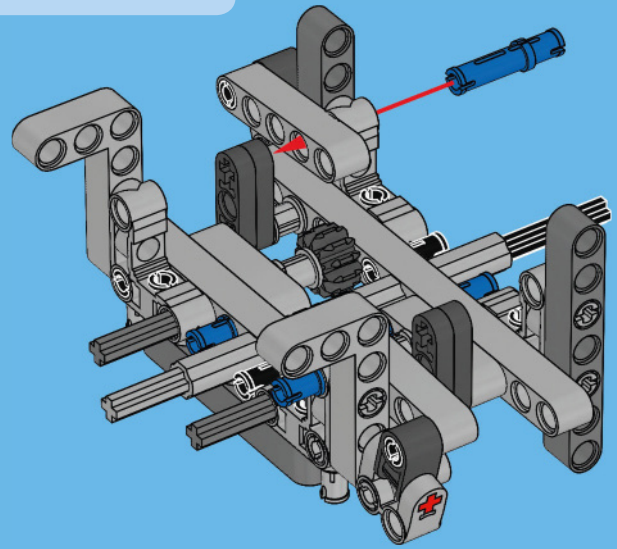

21

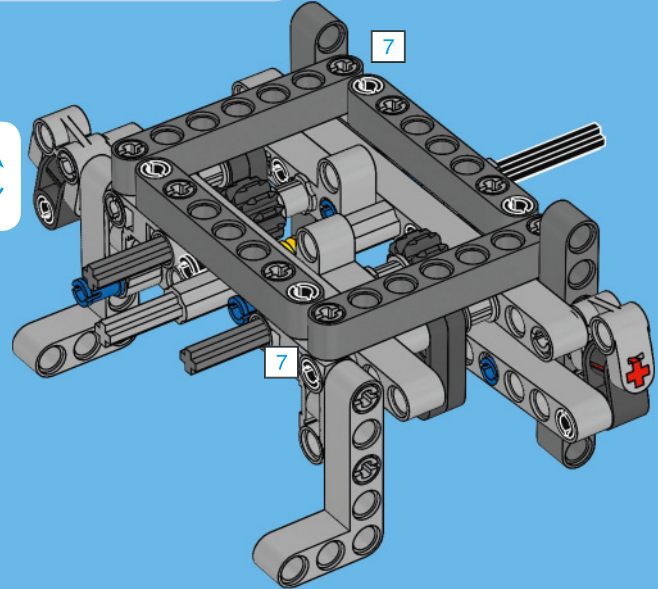

22

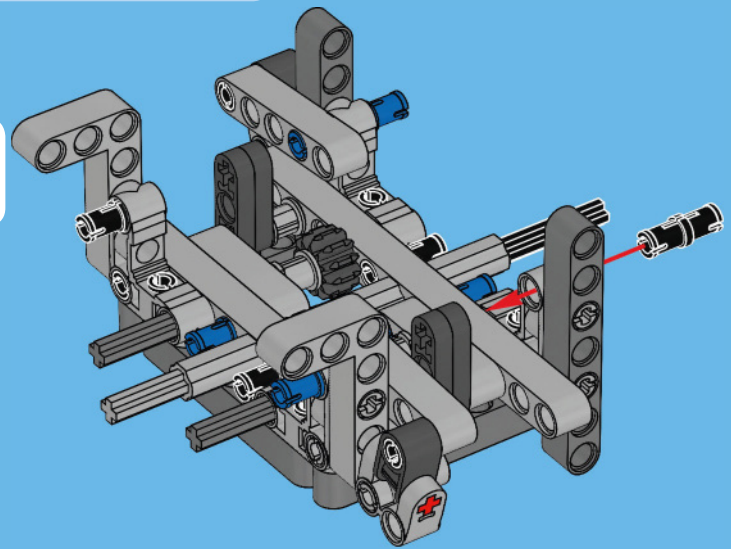

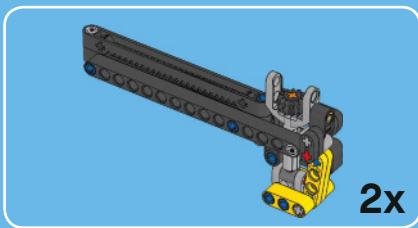

1

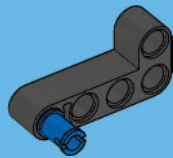

2

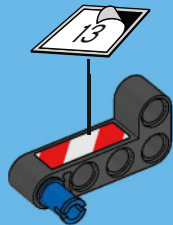

3

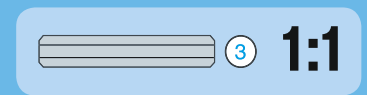
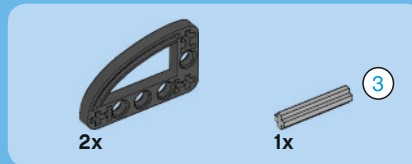
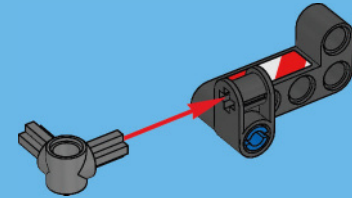

4

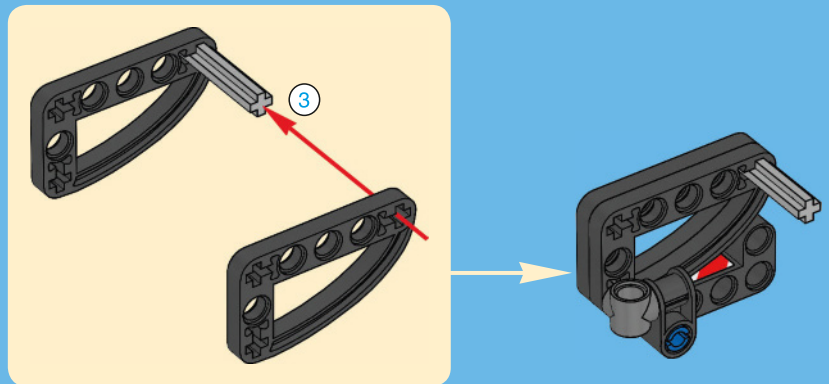



1x



1x

5

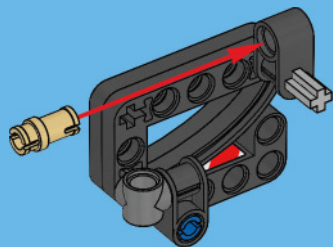

1x



1x



2x



1x

6

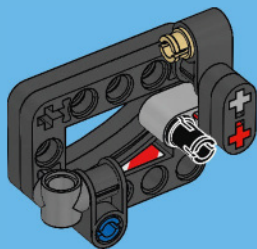

1

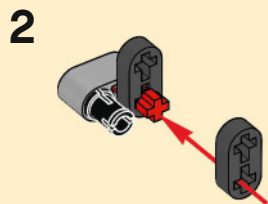

2



1x

1x

7

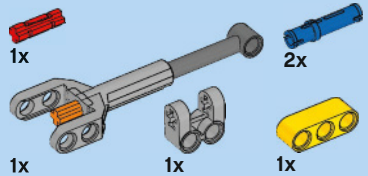

2x

1x

1x

1

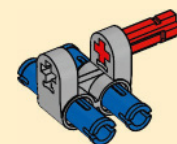

2

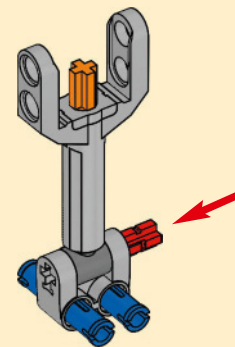

3

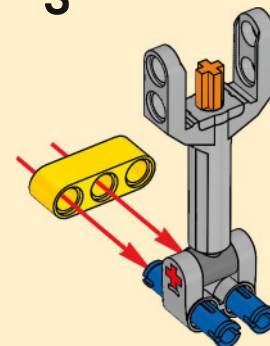





8

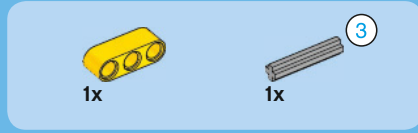
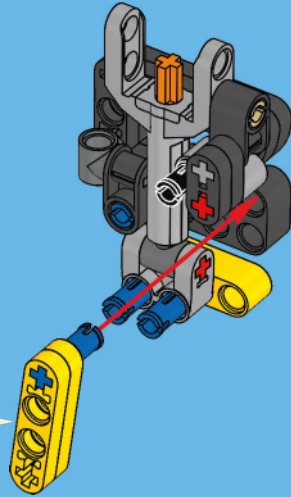
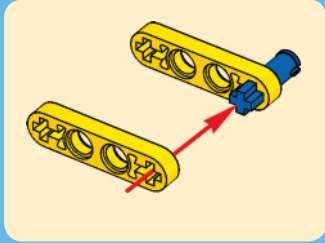

9

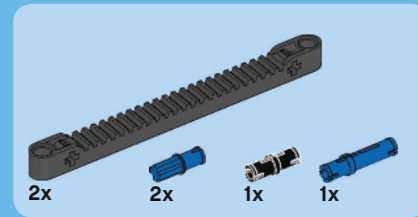
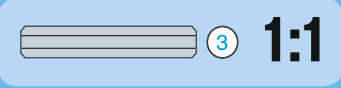
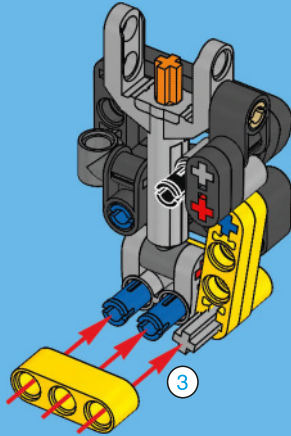

10

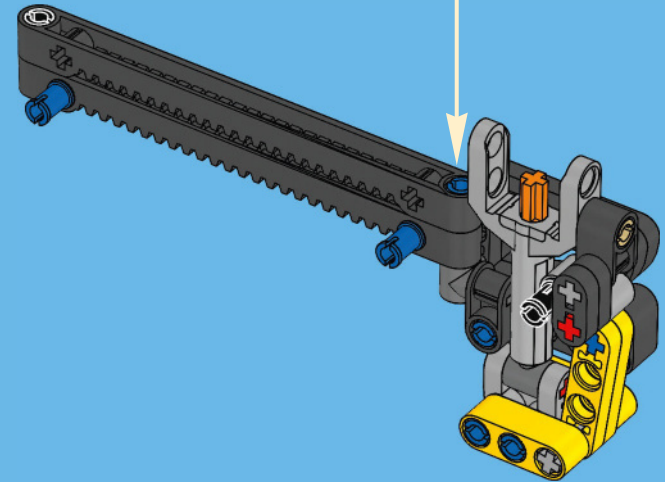
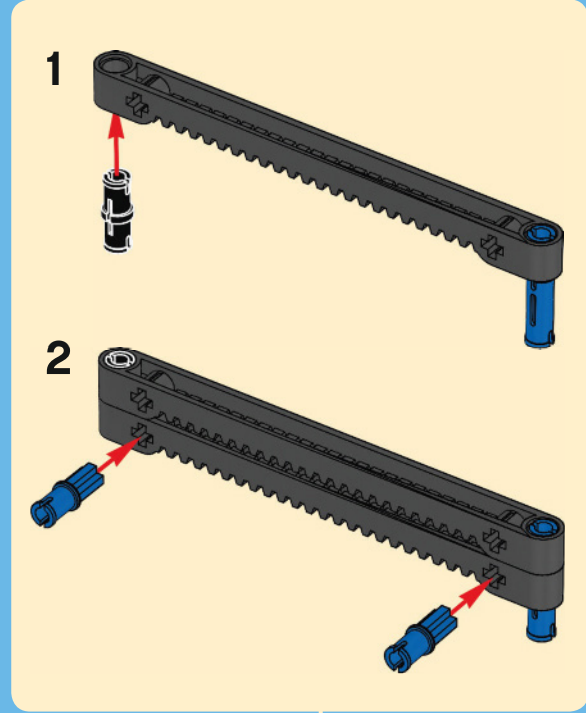

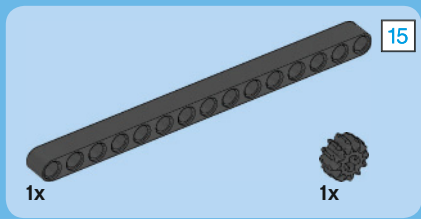

11

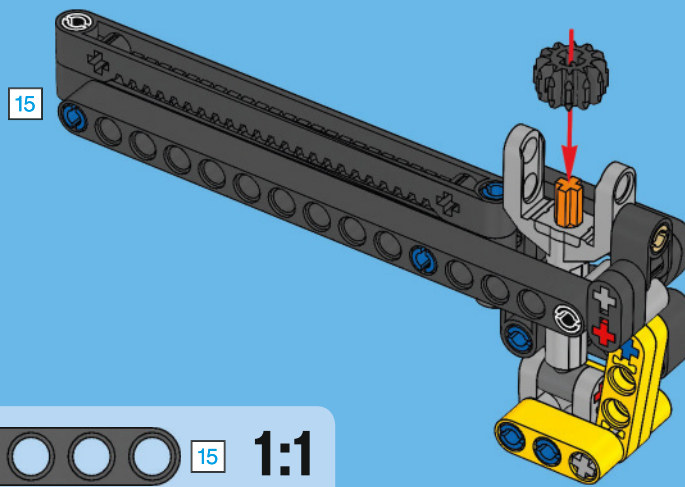

2x

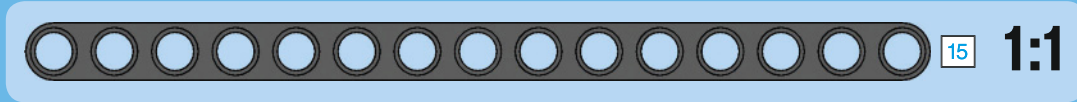

23

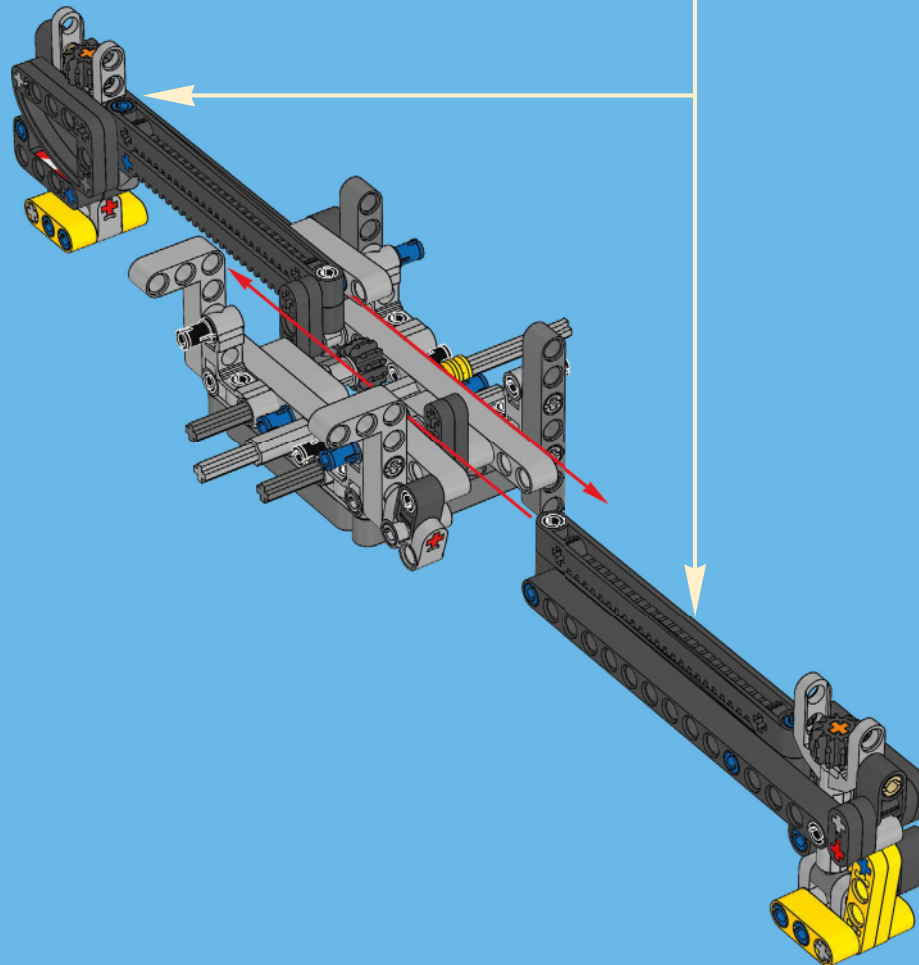

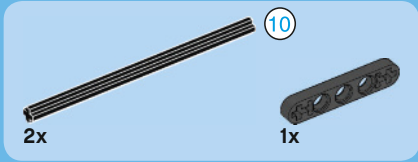
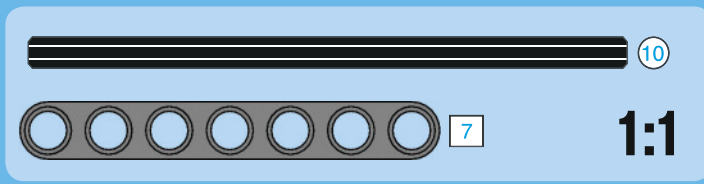
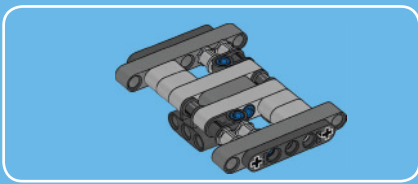

1

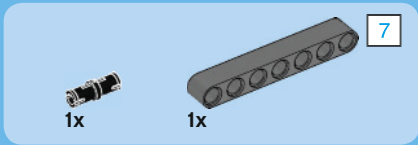
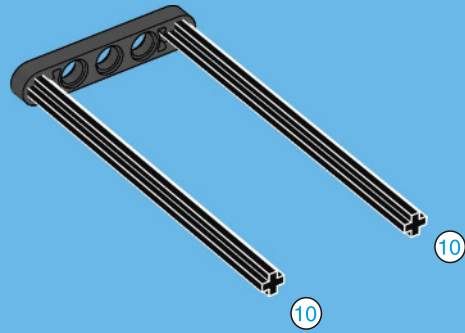

2

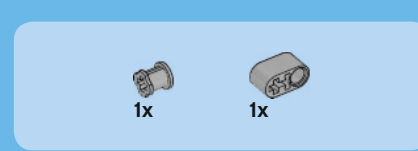
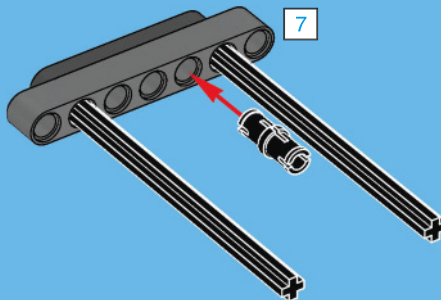

3

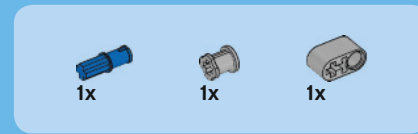
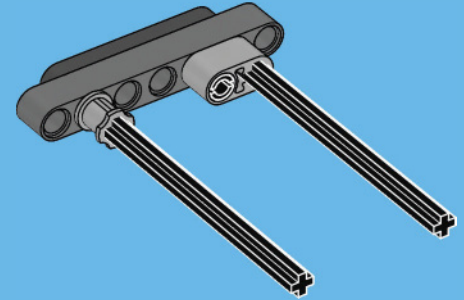

4

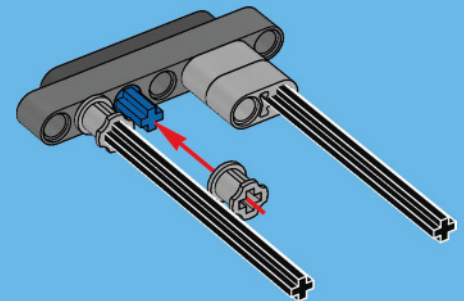



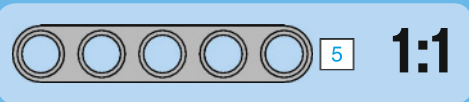
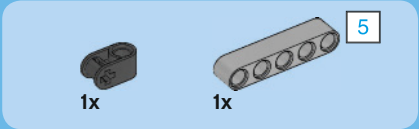

5

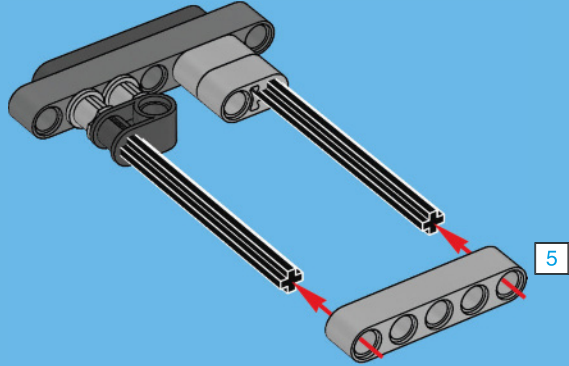

6

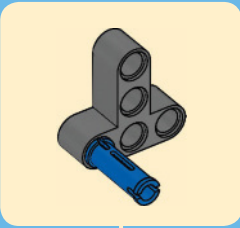
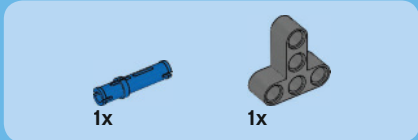
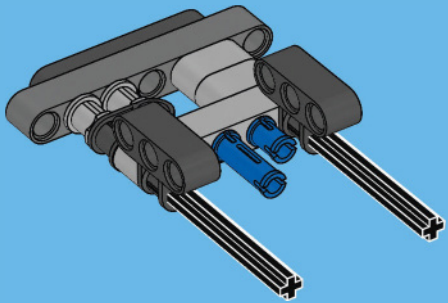

7

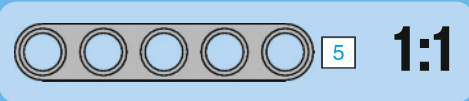
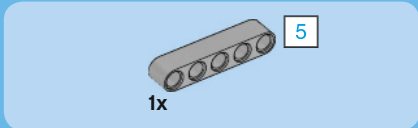
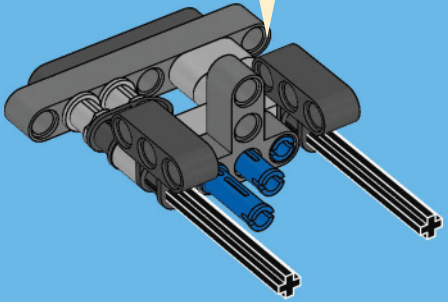

8

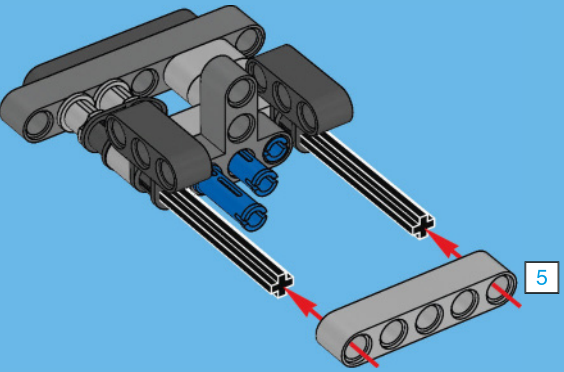



9

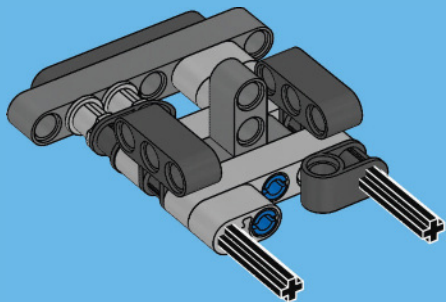

10

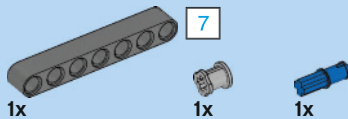
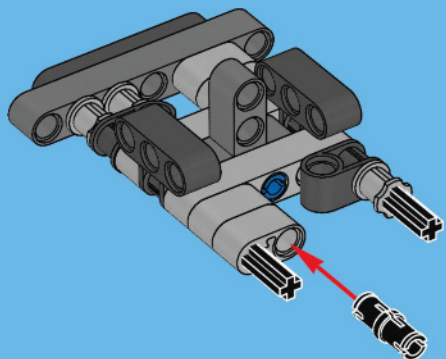

11

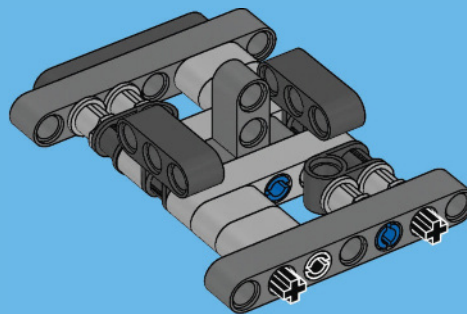

12

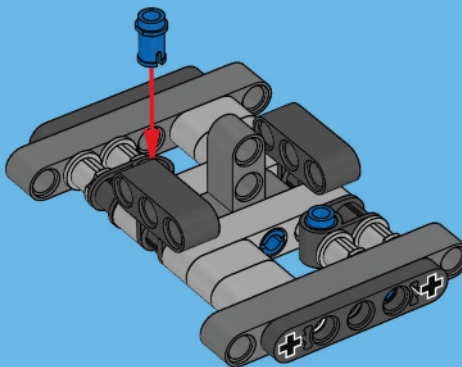

13

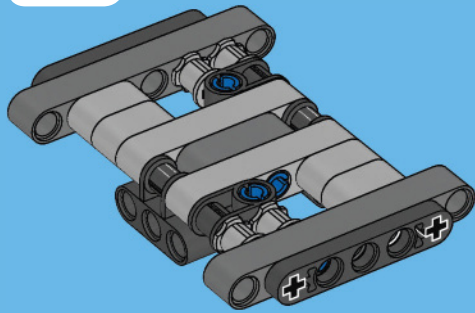

25

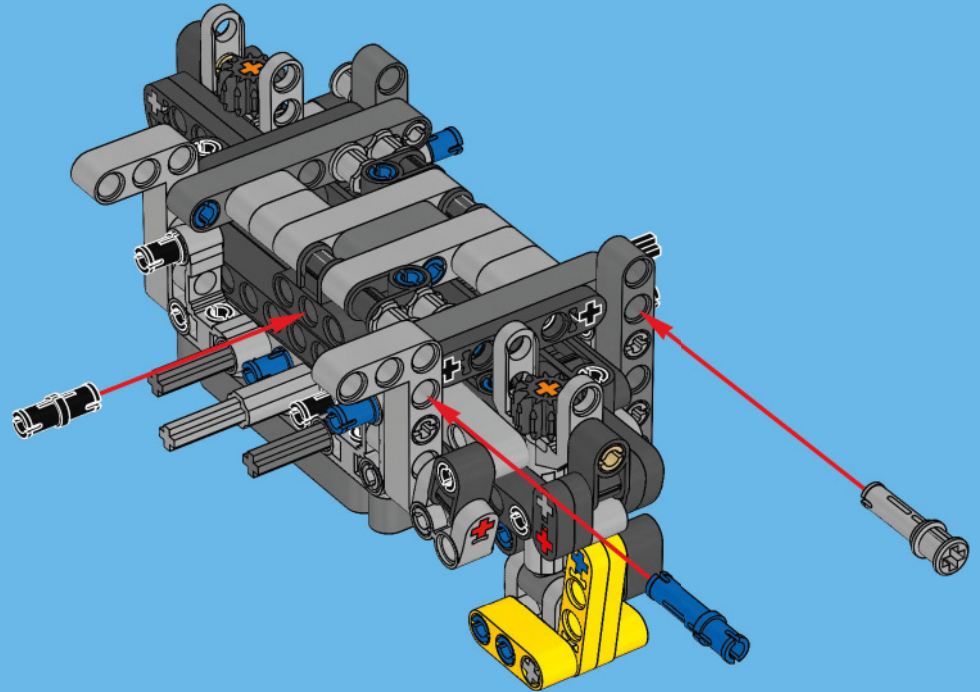

24

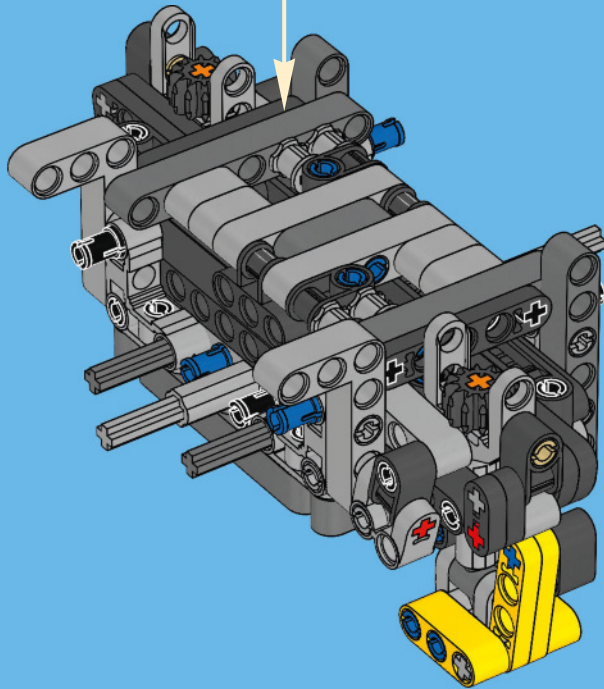





2x

# 26

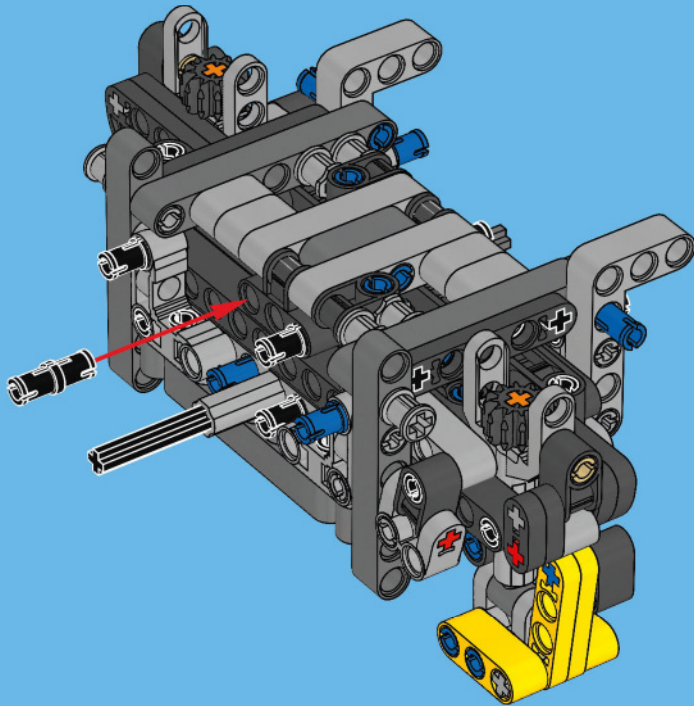

2x



1x

3



1x



3

1:1

# 27

1

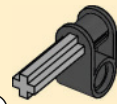

3

2

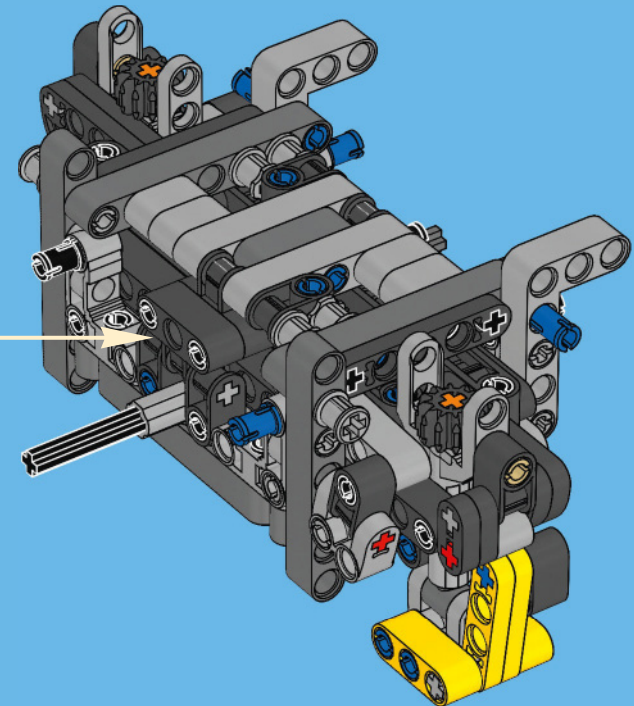
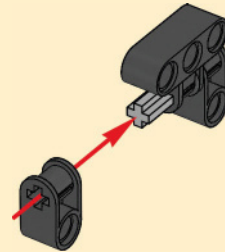

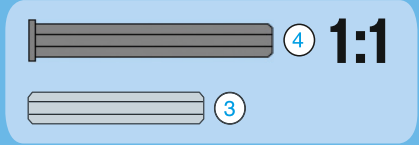
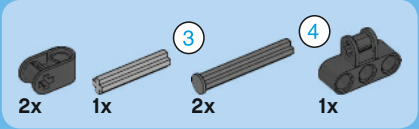

# 28

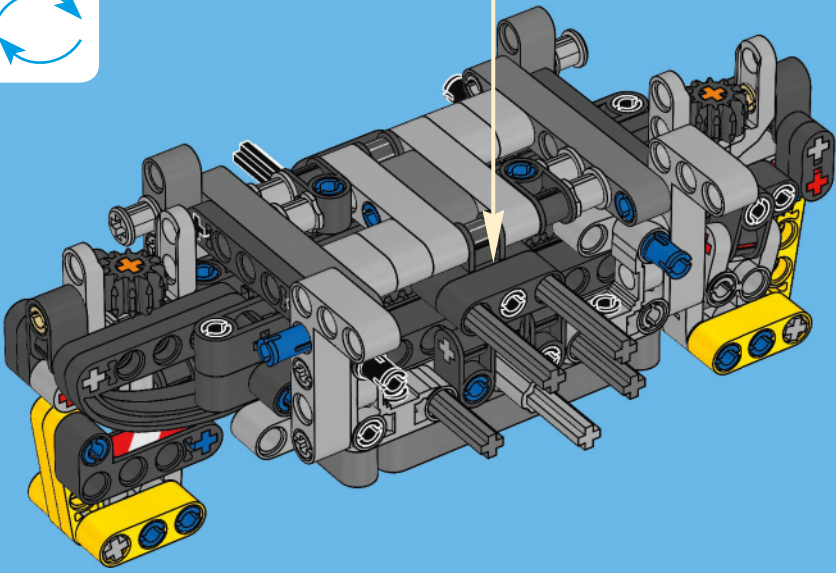
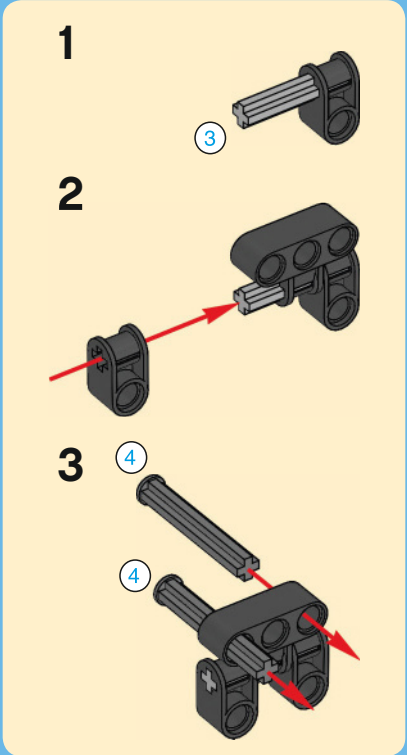

# 29

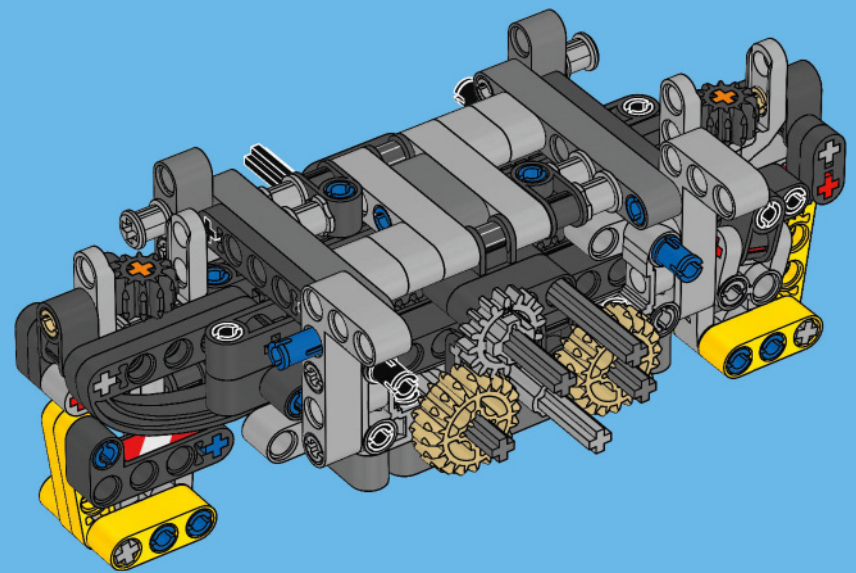

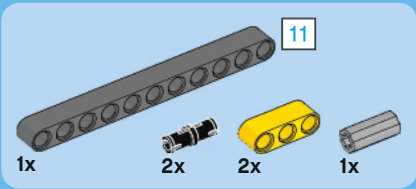

30

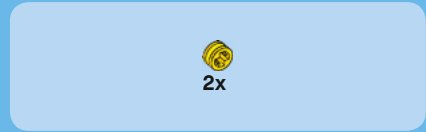
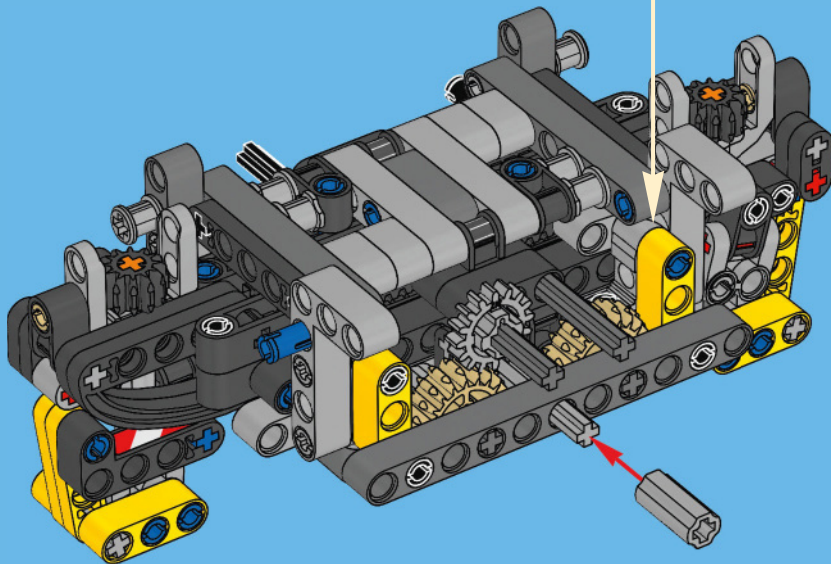
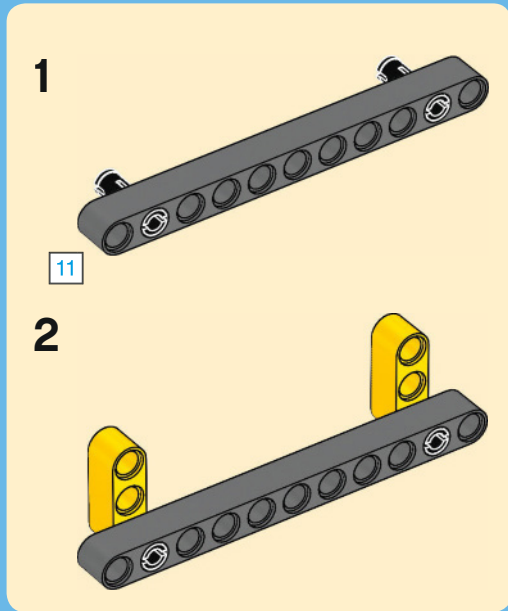

31

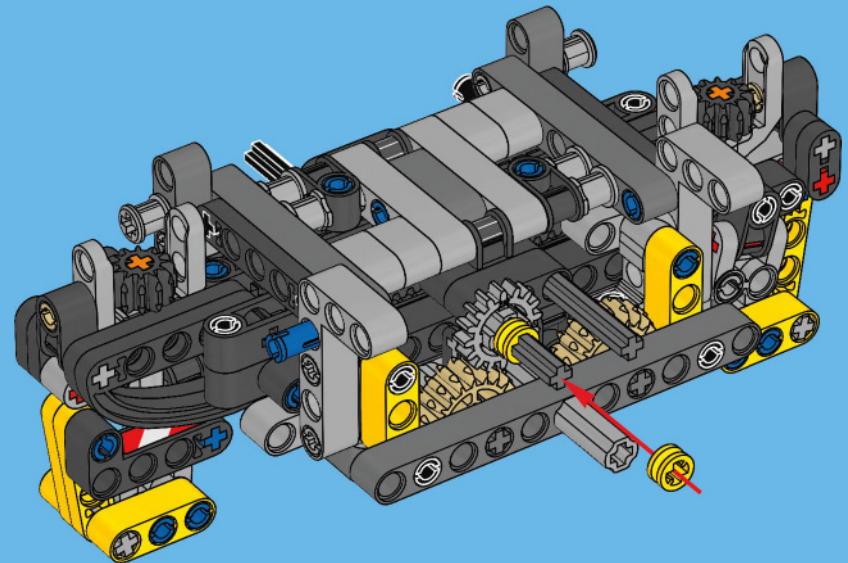



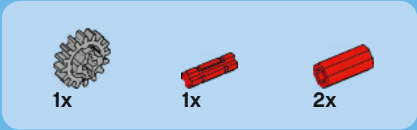

32

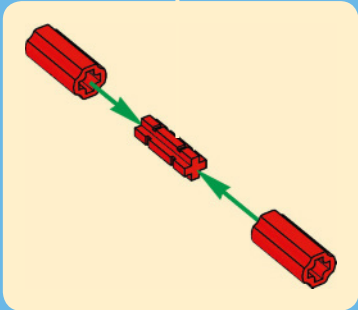
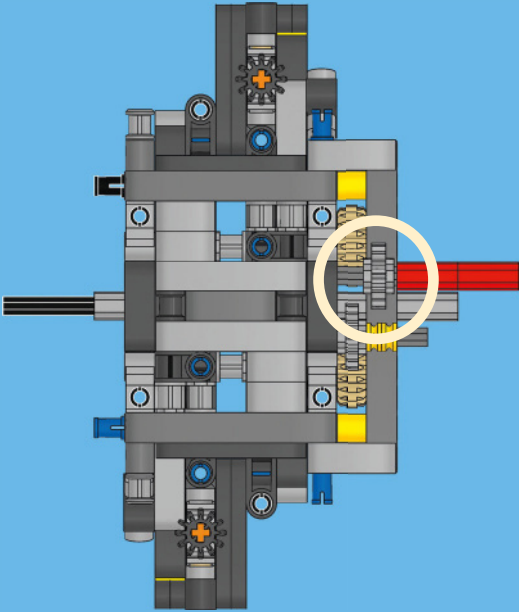
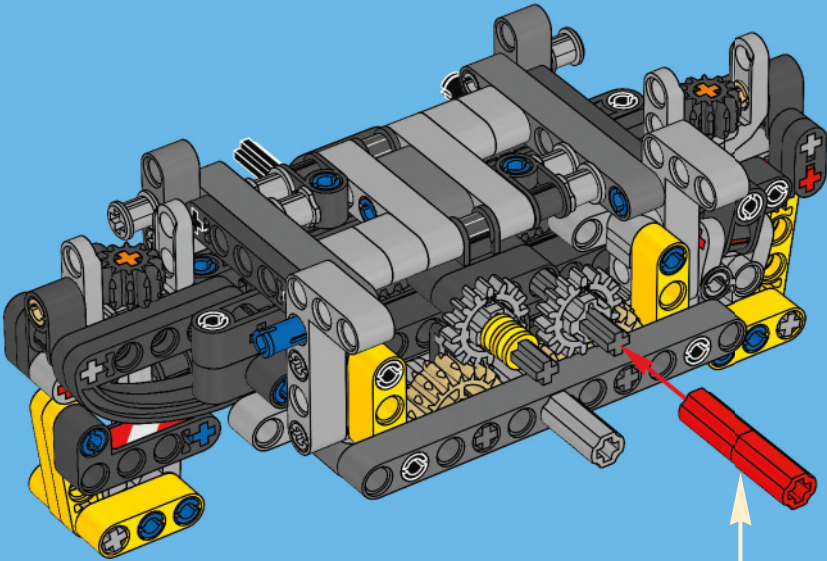



2x



2x

# 33

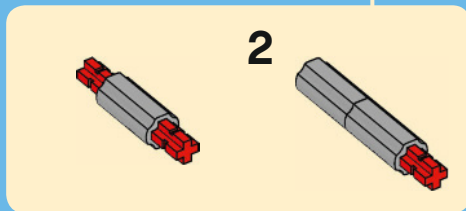
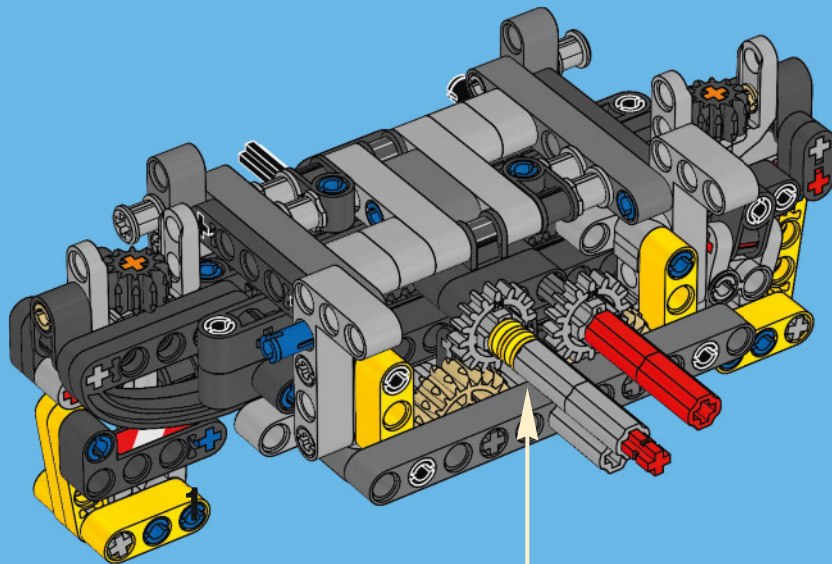

2x



2x



2x

# 34

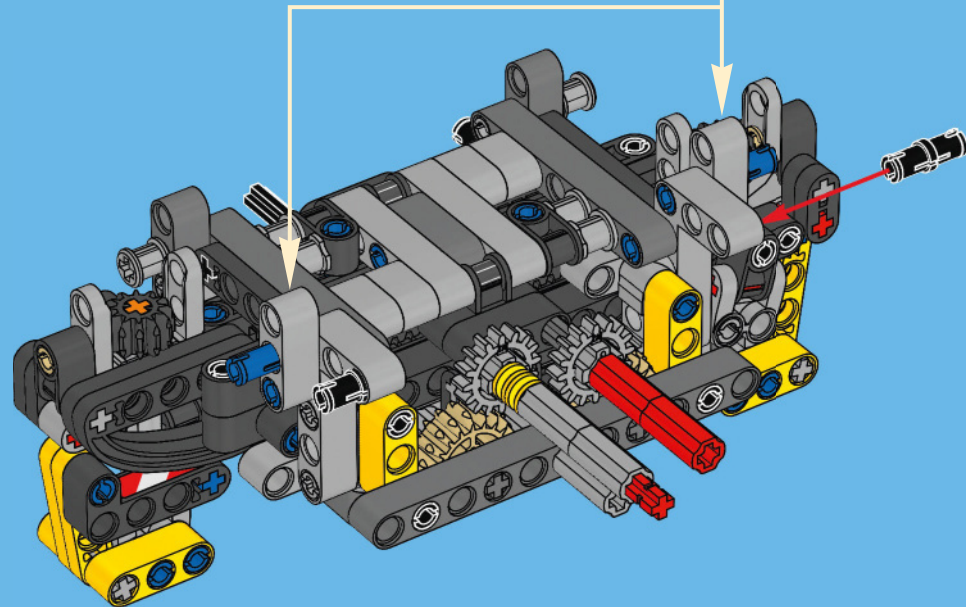
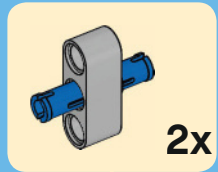

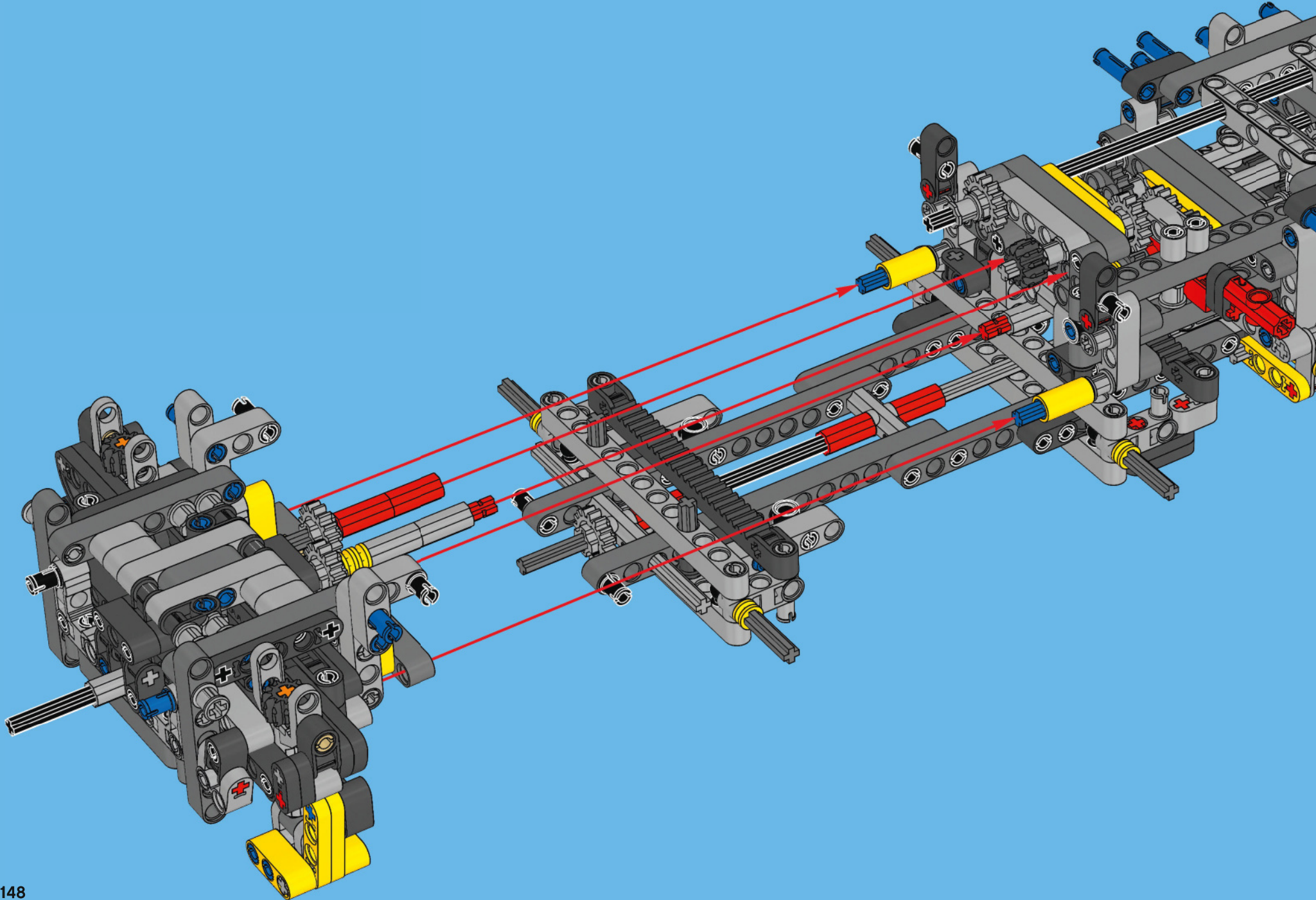





2x

# 97

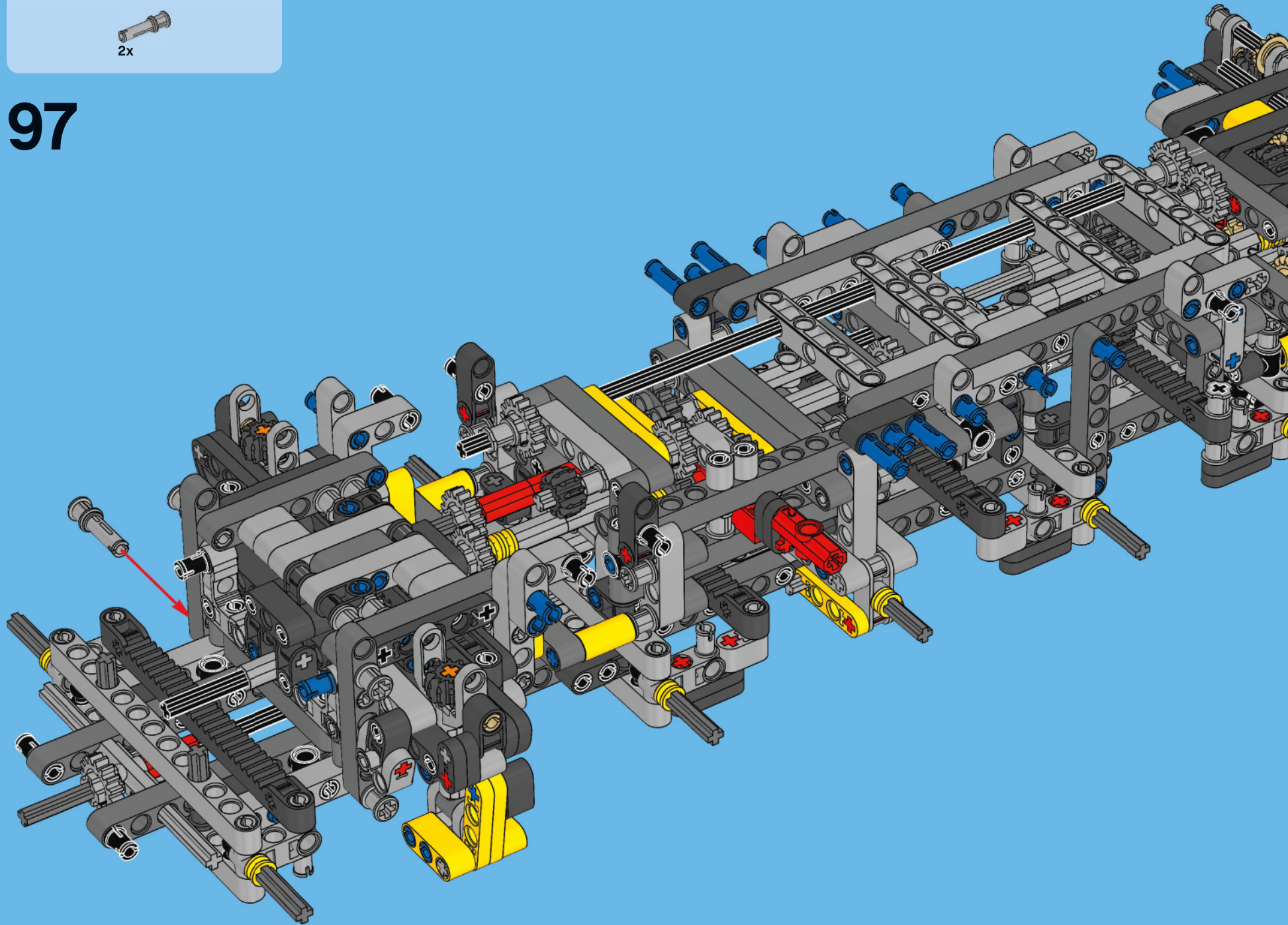

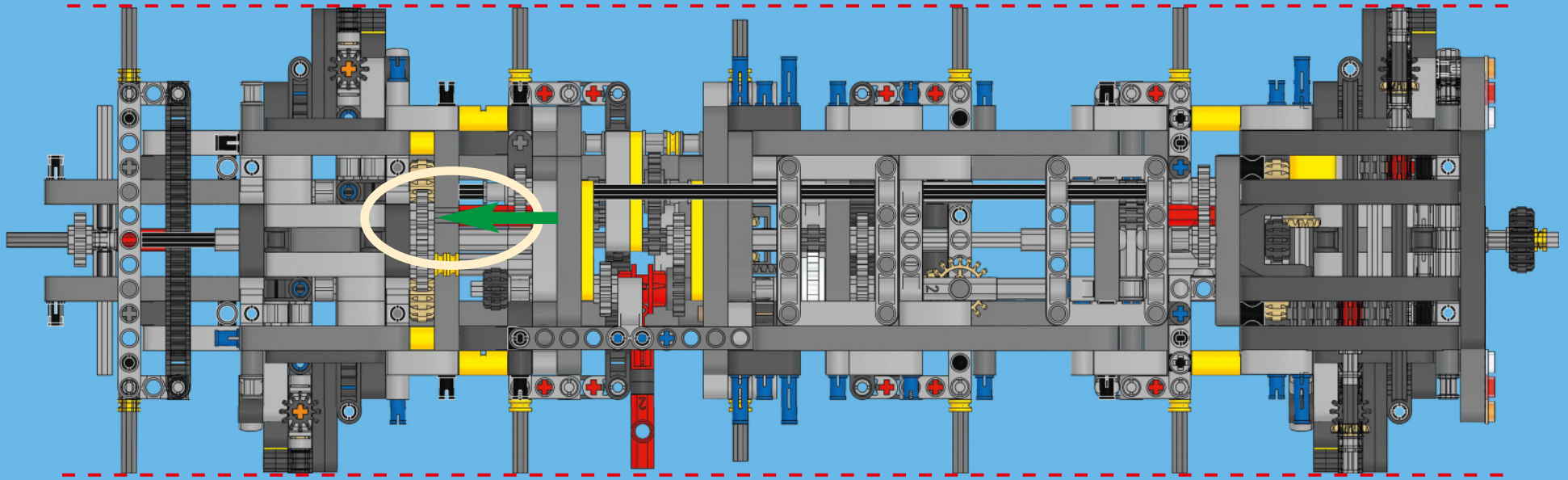
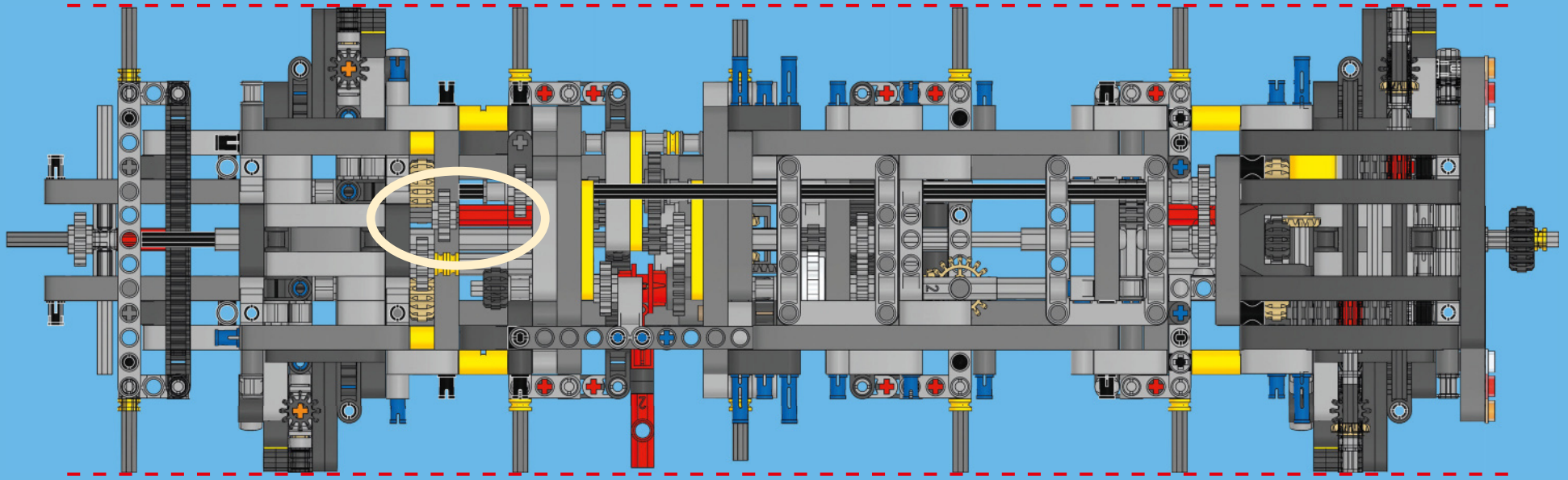





1x



1x

# 98

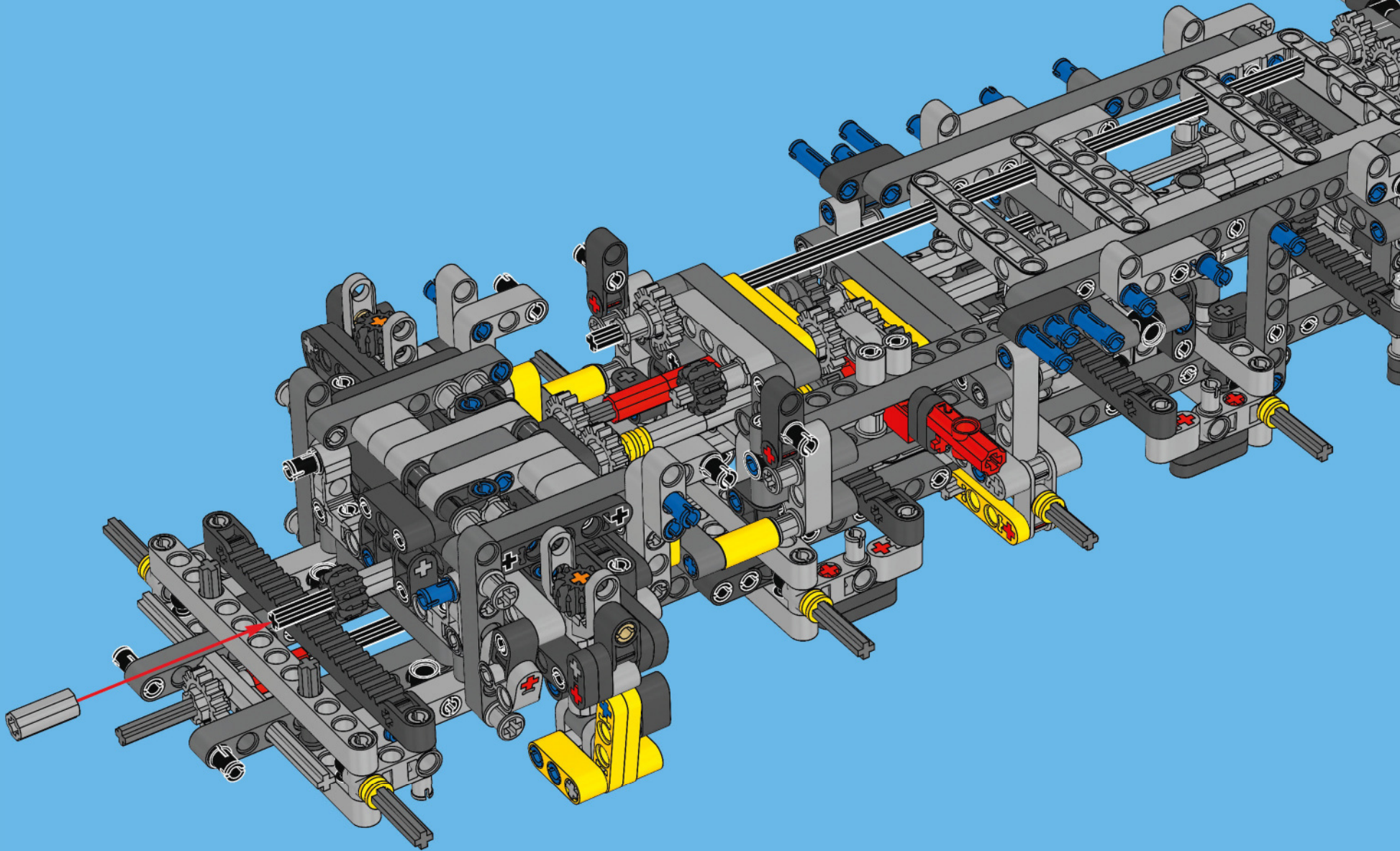



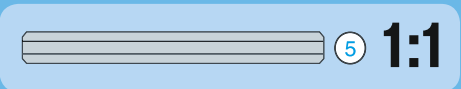
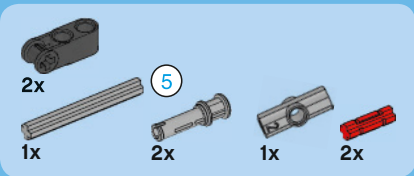

# 99

- 1
- 2
- 3

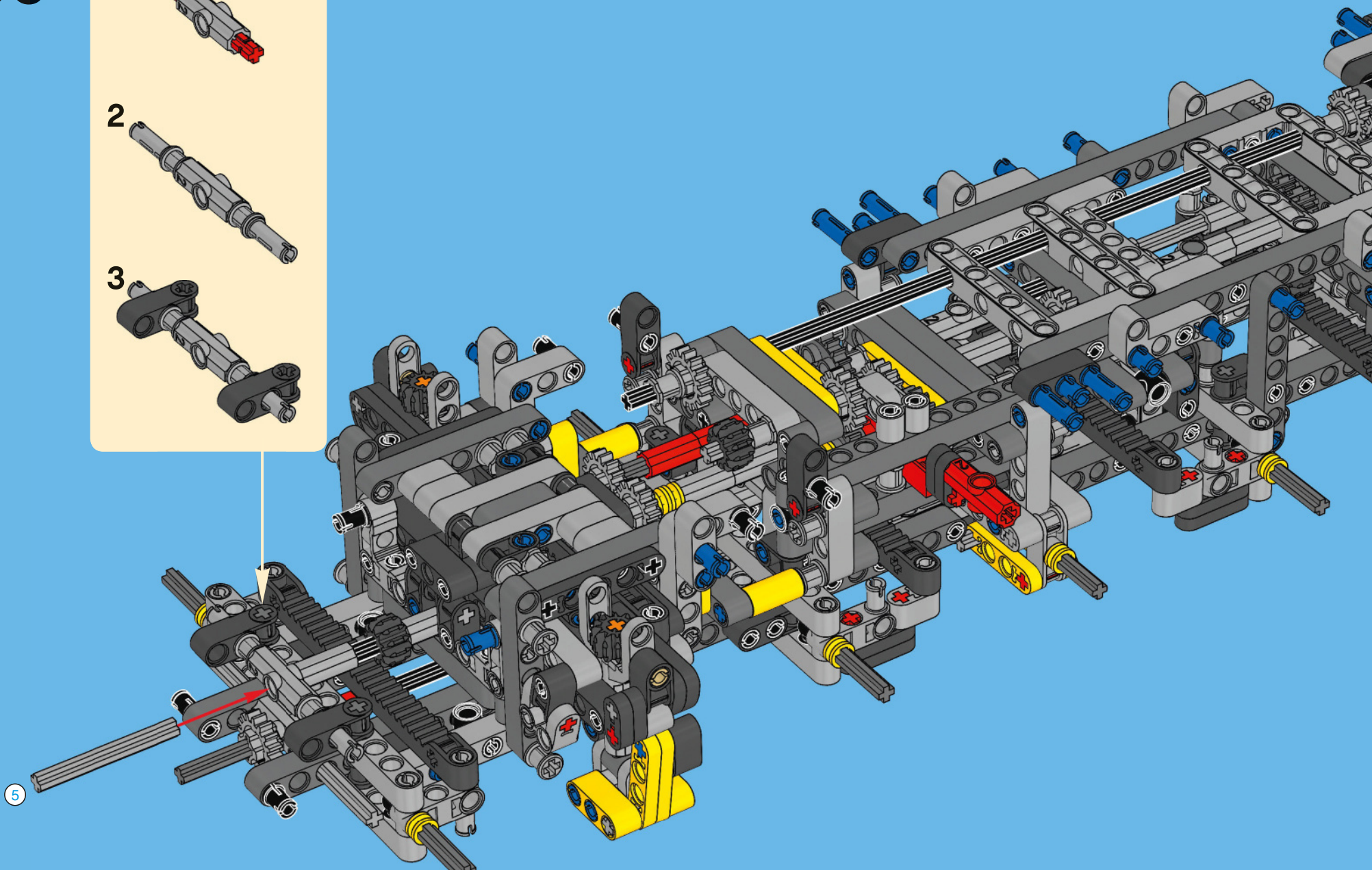

100

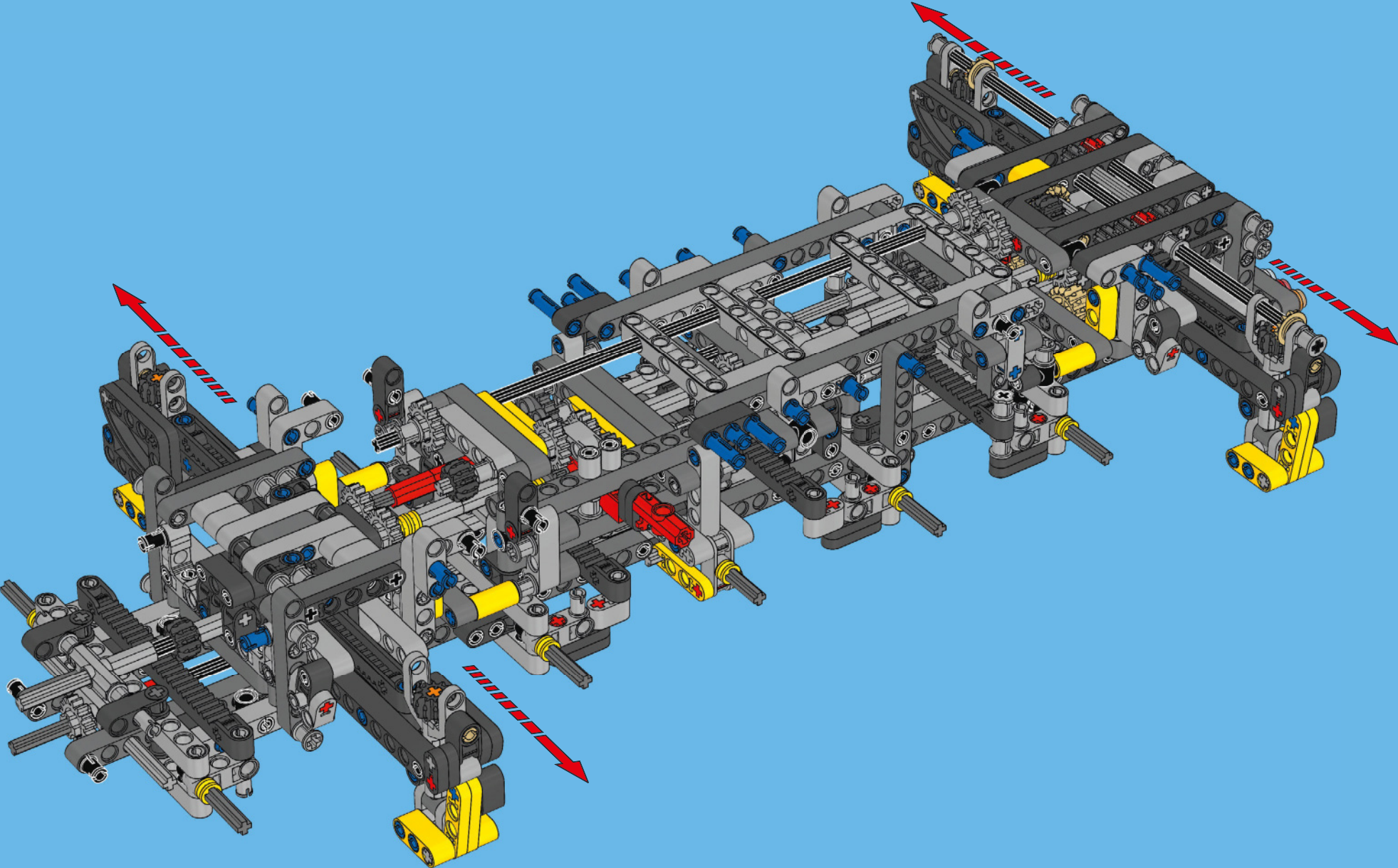

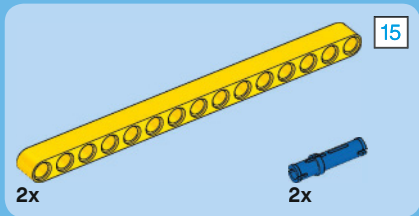

101

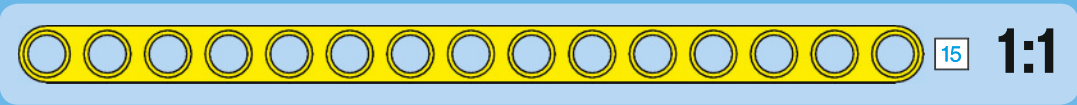

1

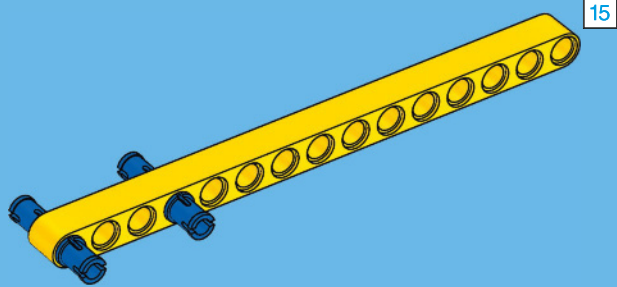

2

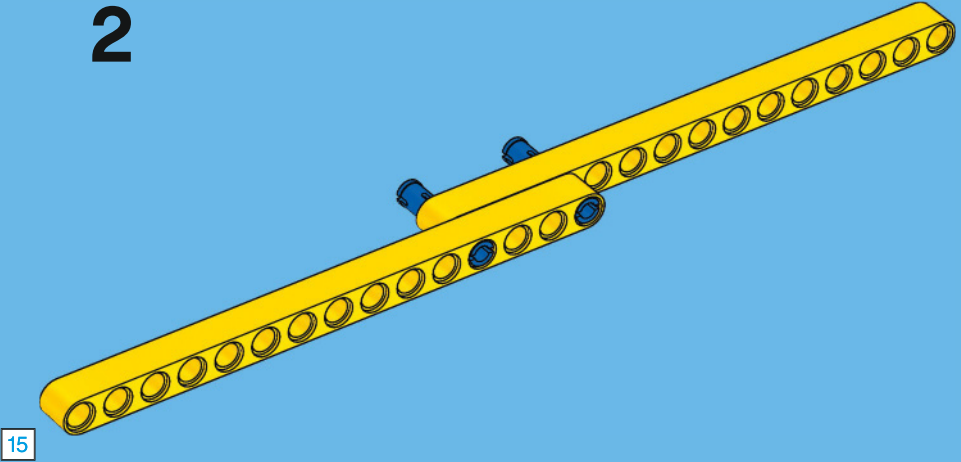



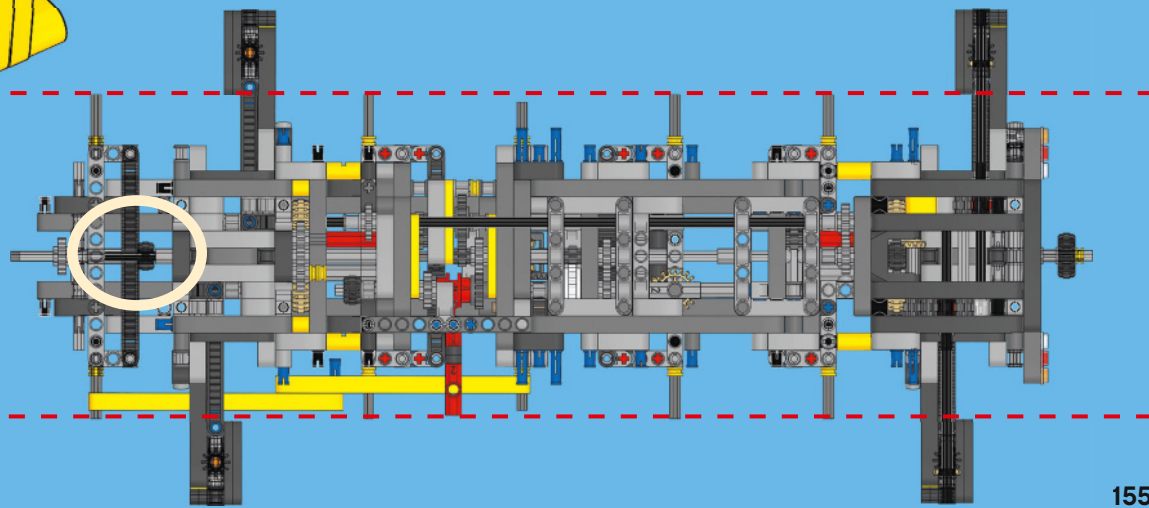
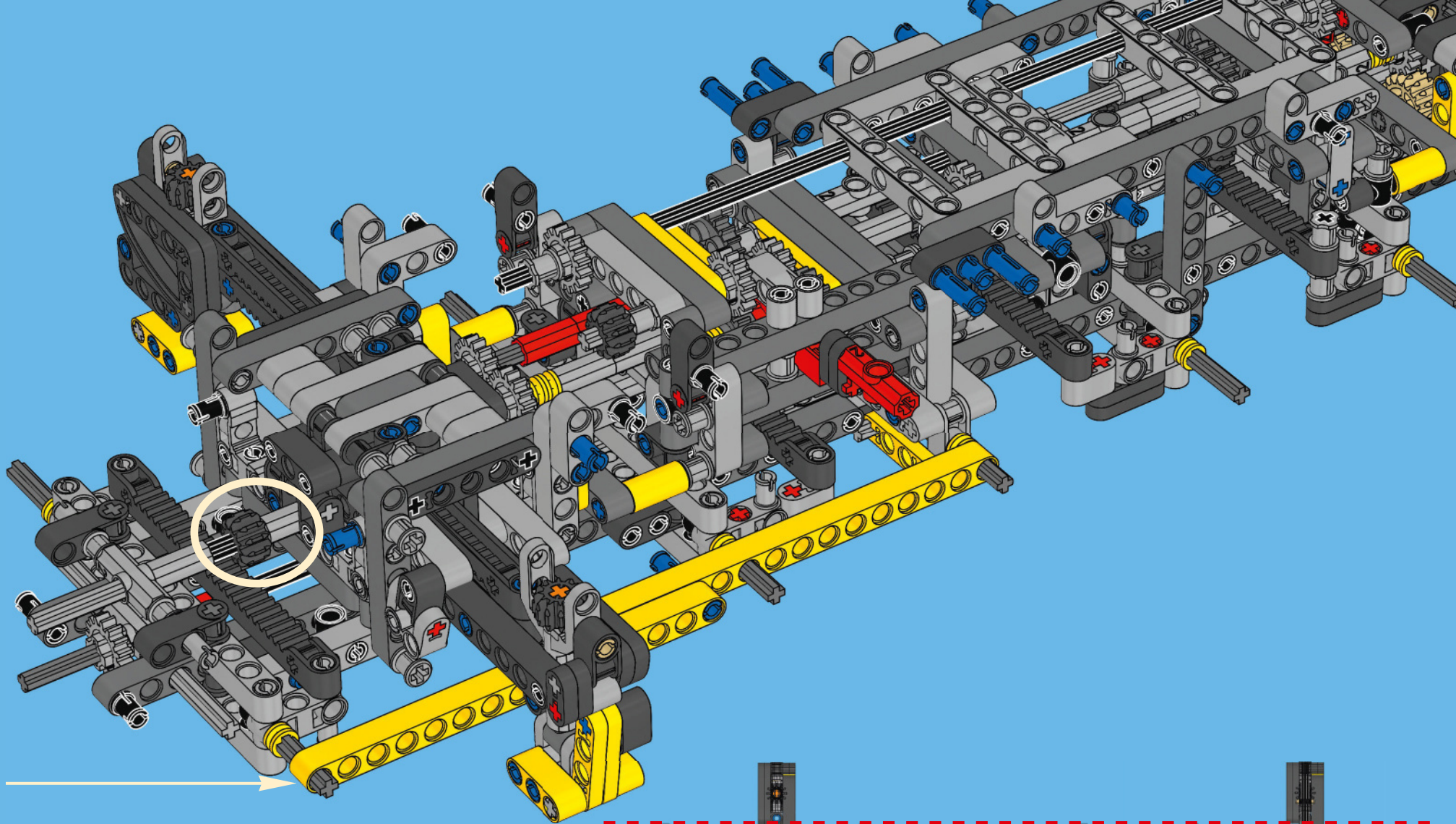



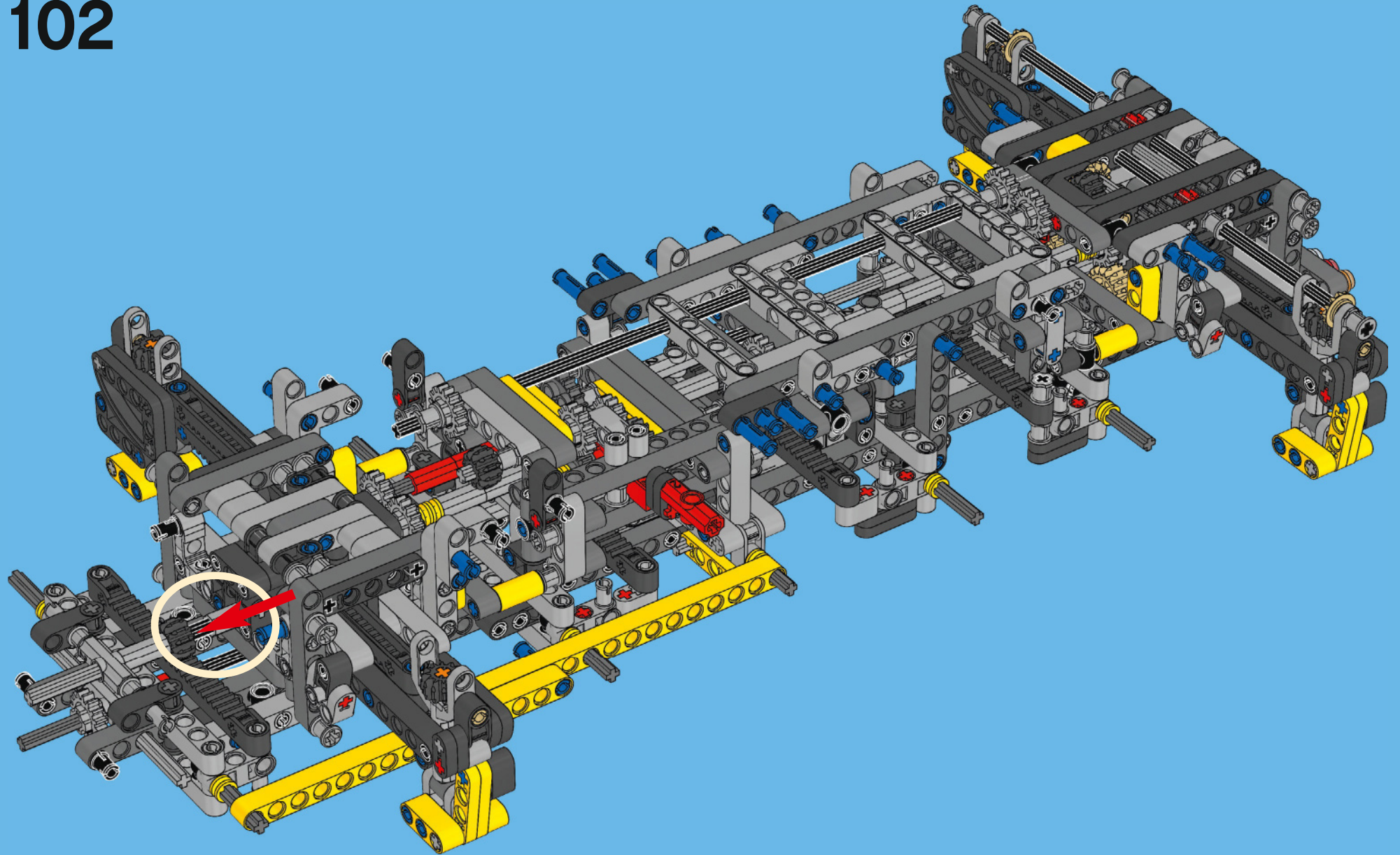

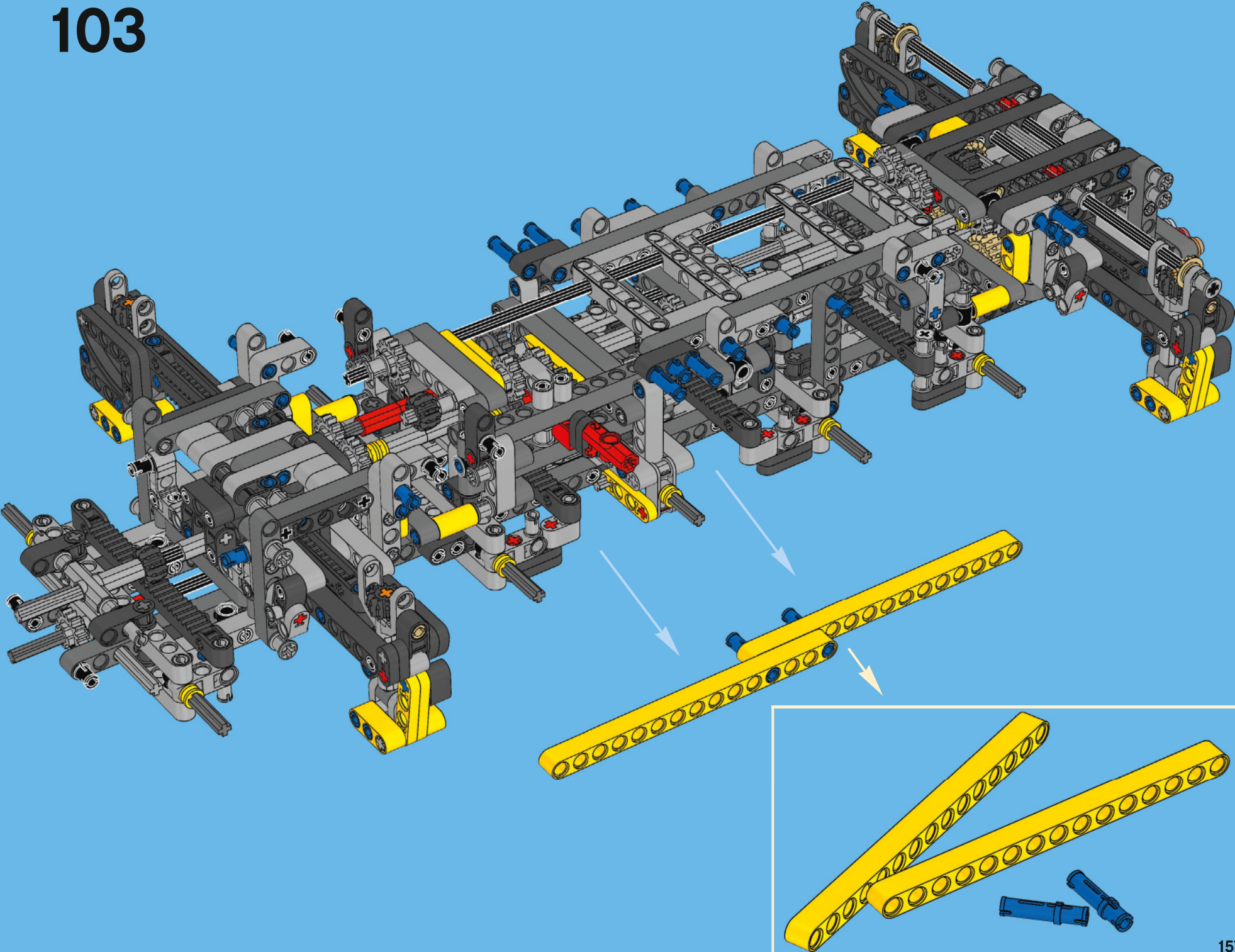



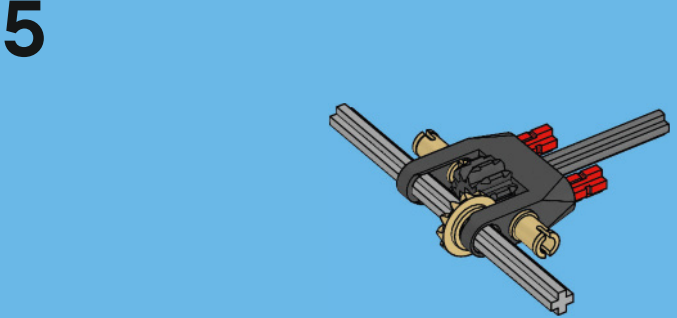
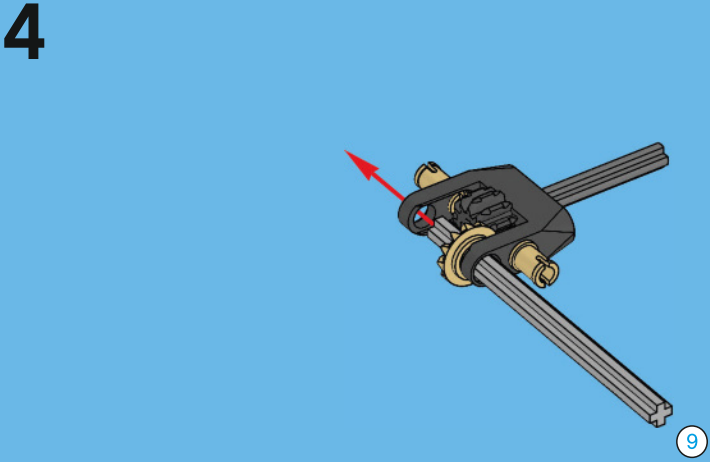
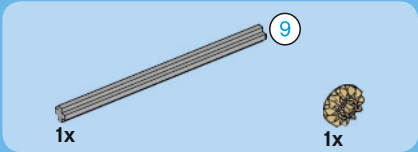
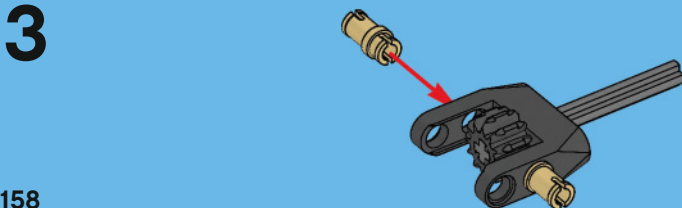
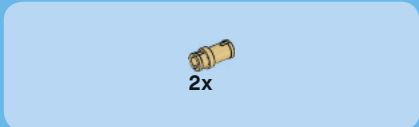
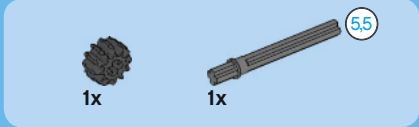
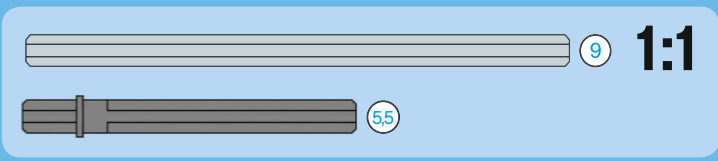
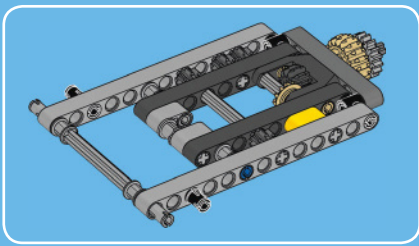

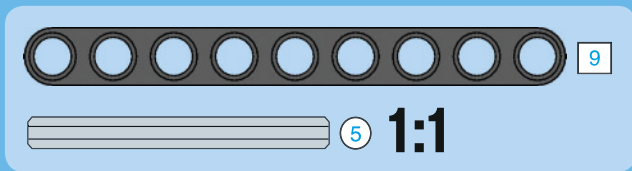
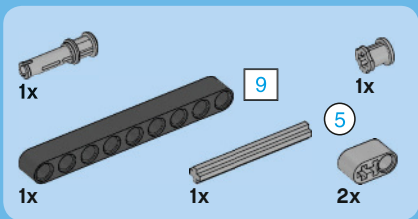

6

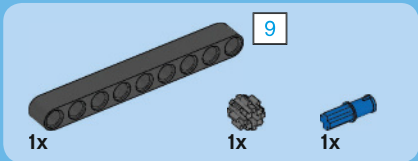
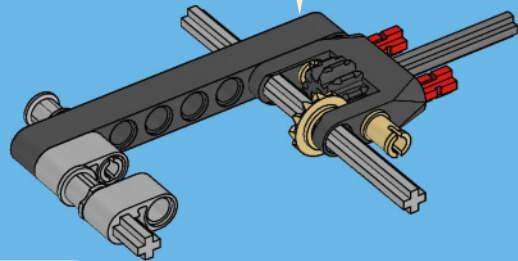
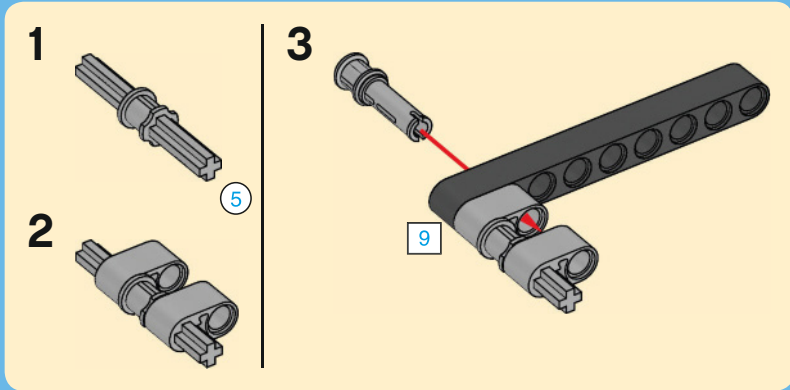

7

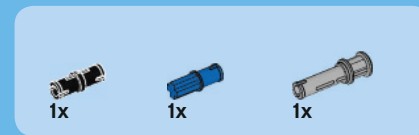
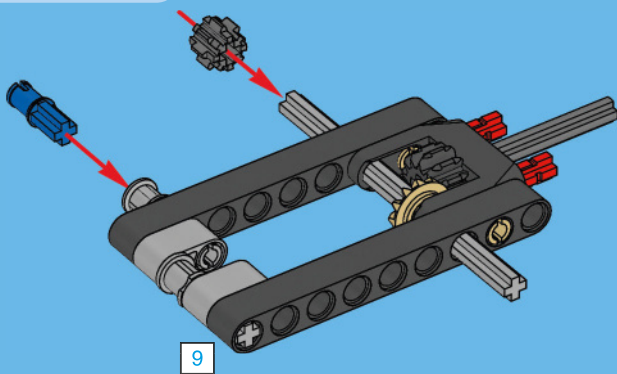

8

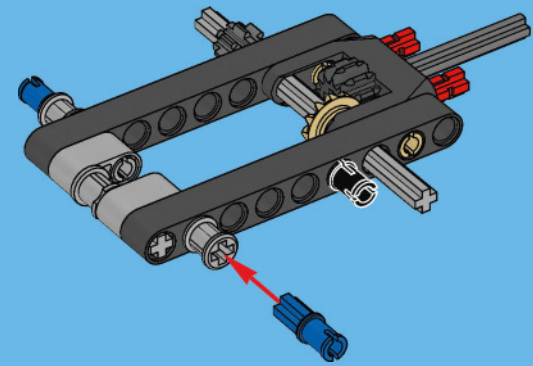

9

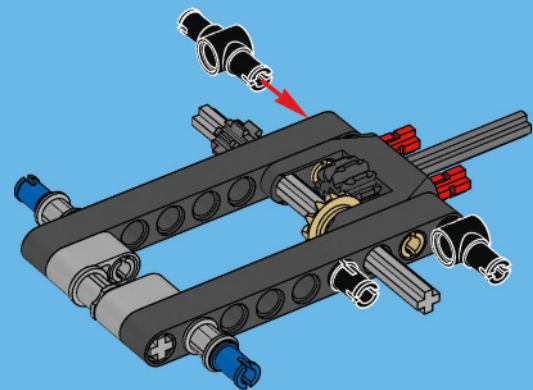

# 10

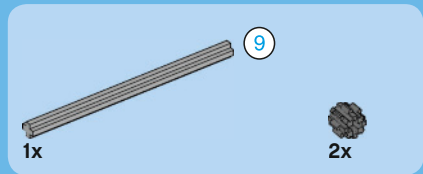
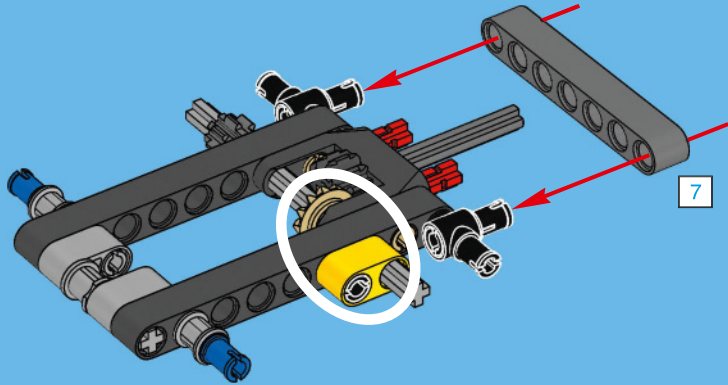
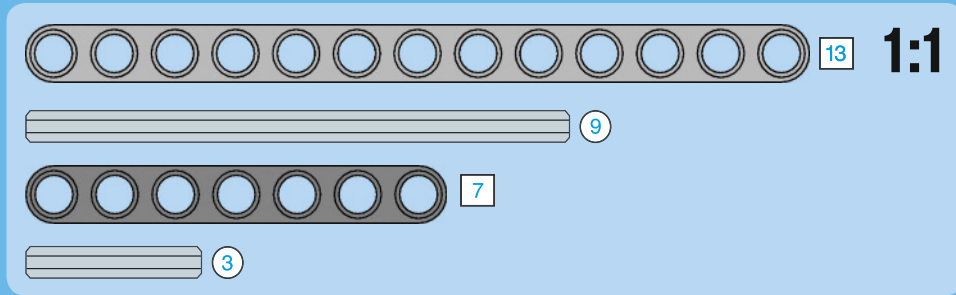

# 11

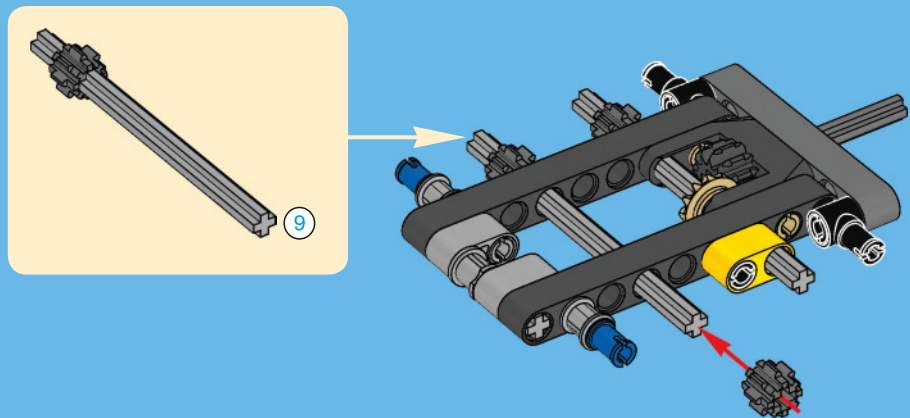

# 12

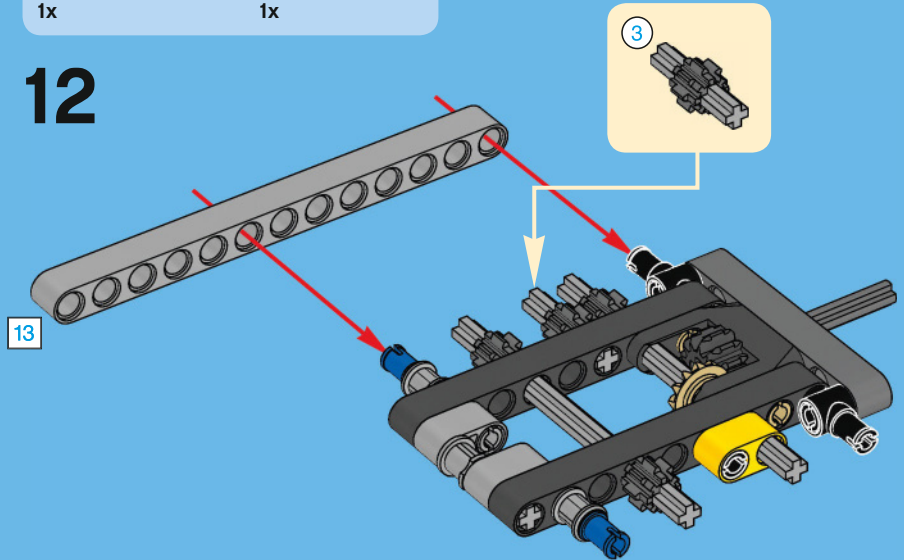
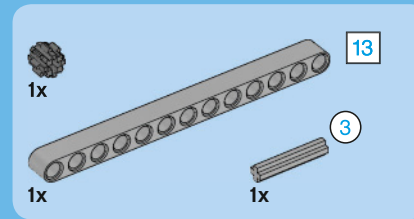



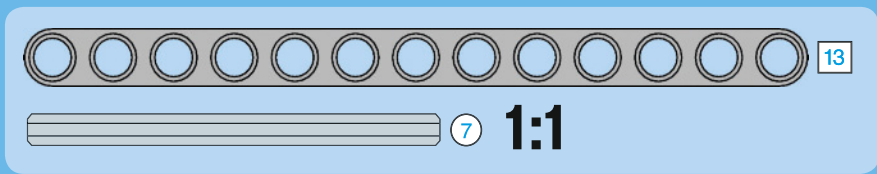
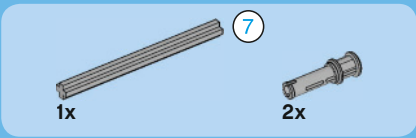

13

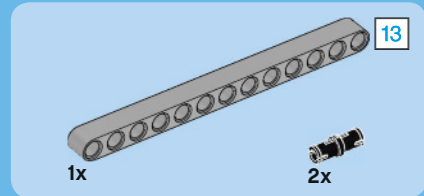
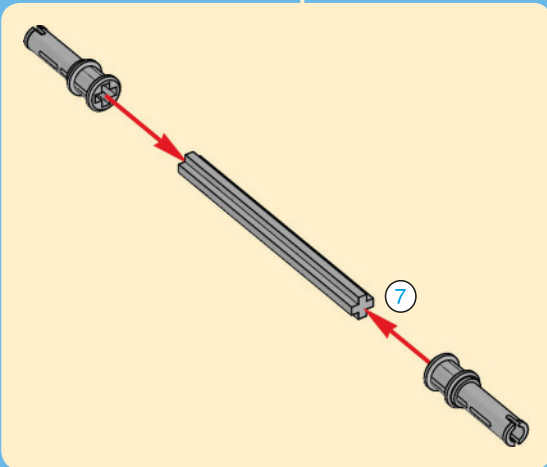
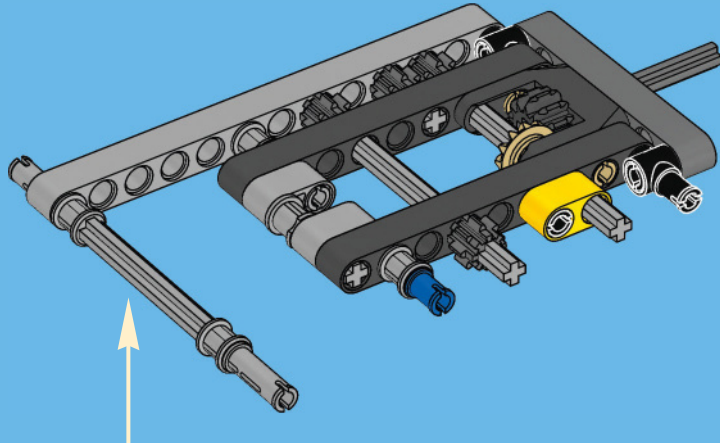

14

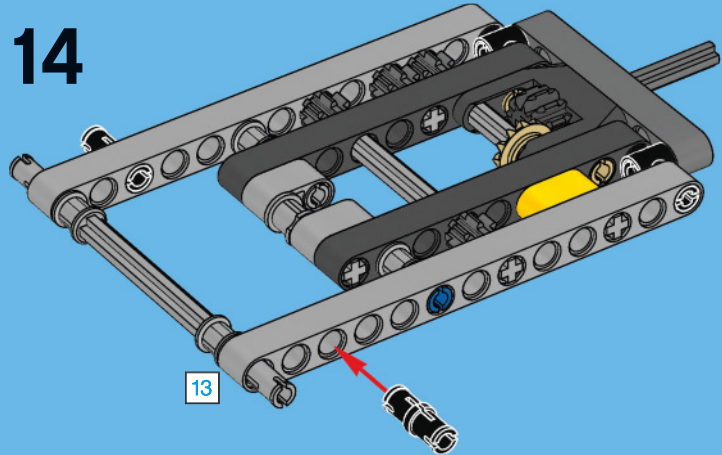

15

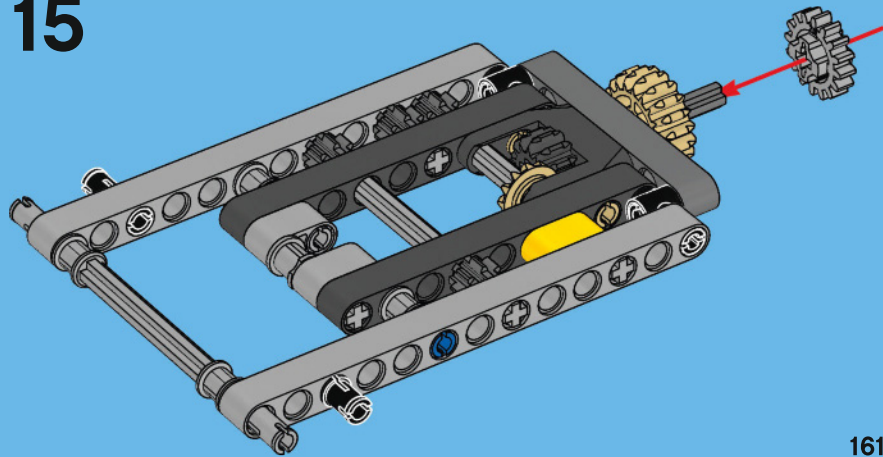

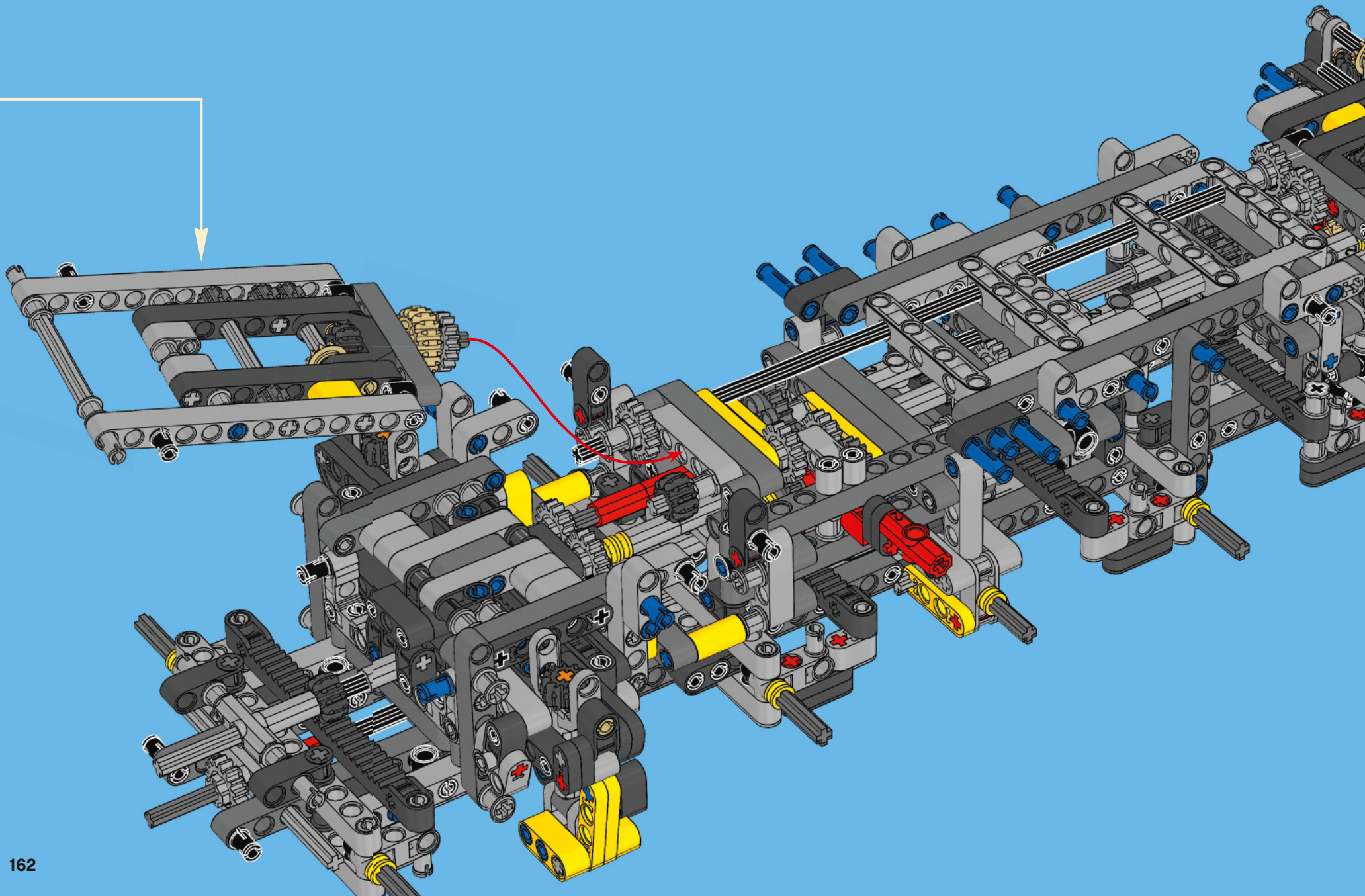





2x



2x



2x

# 105

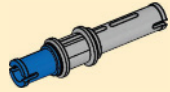

2x

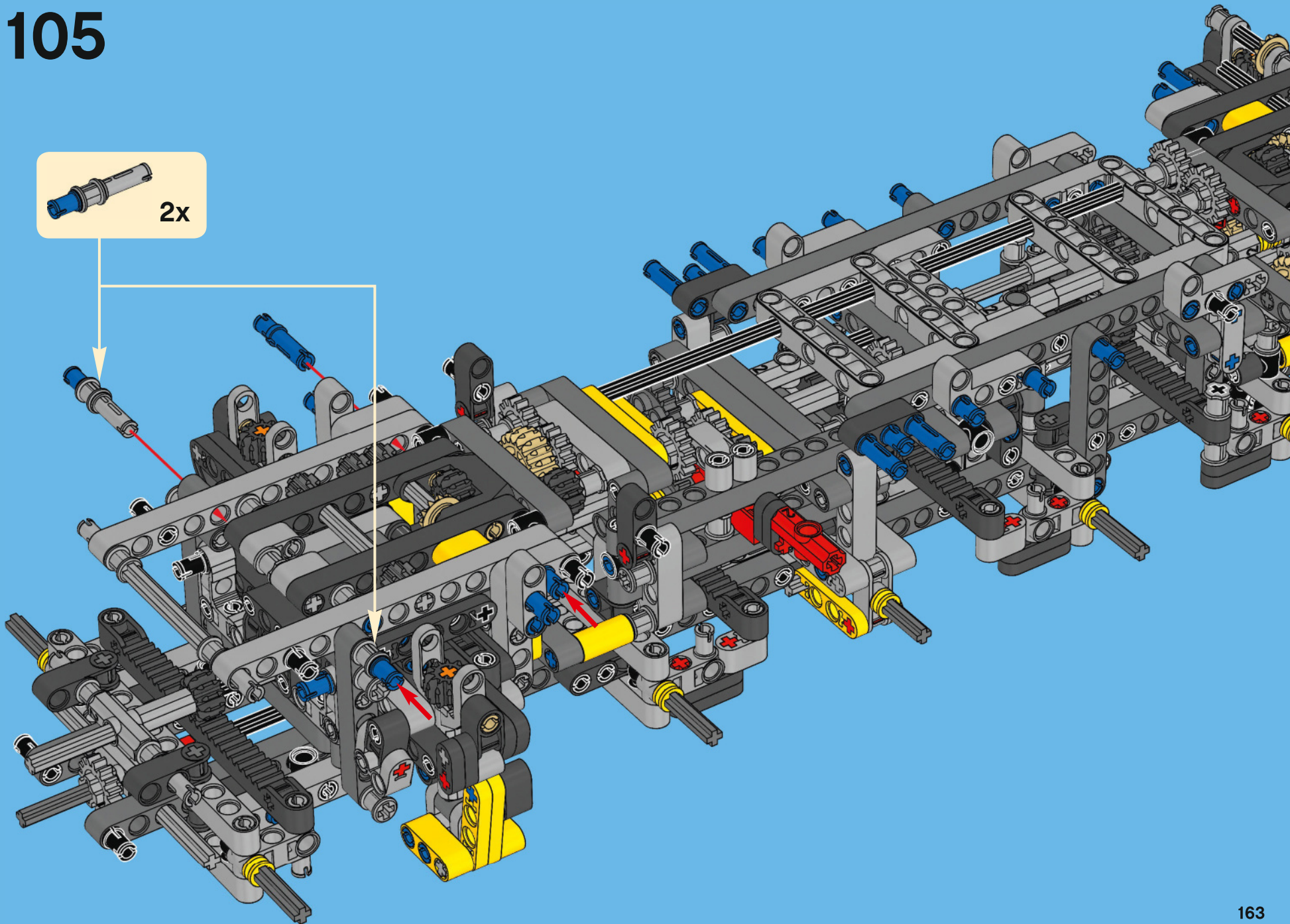



16

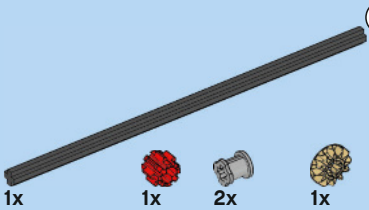

# 106

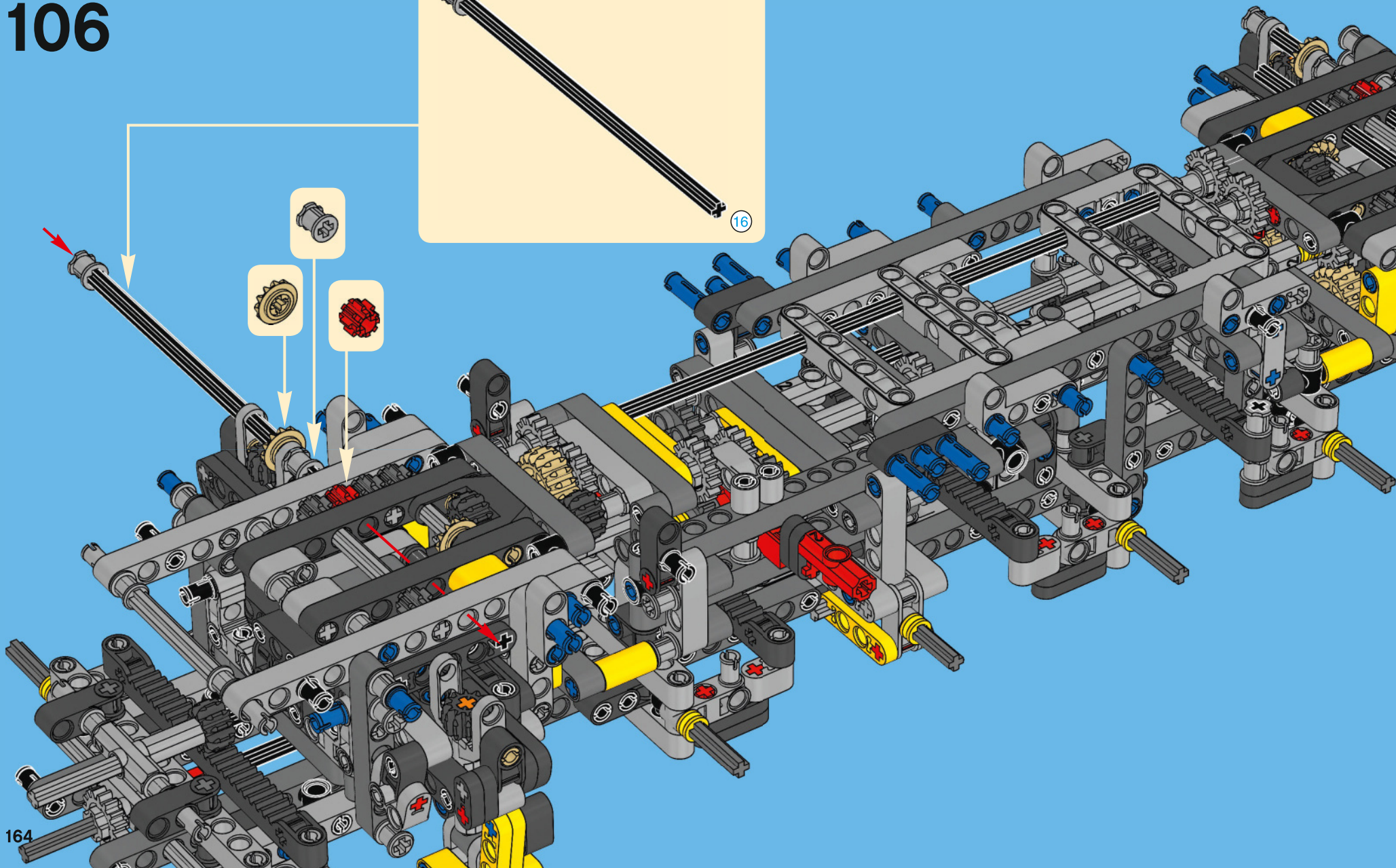
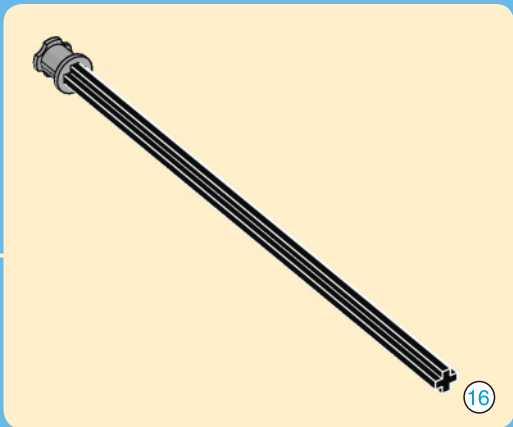



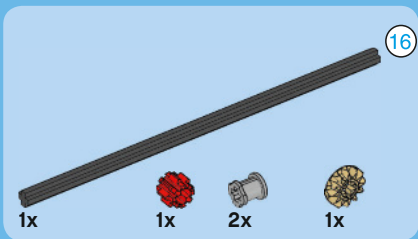

107

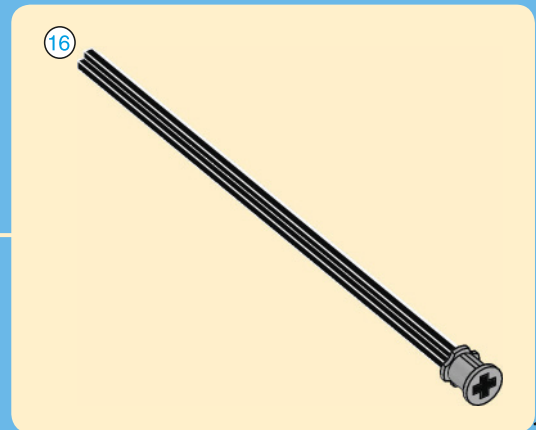
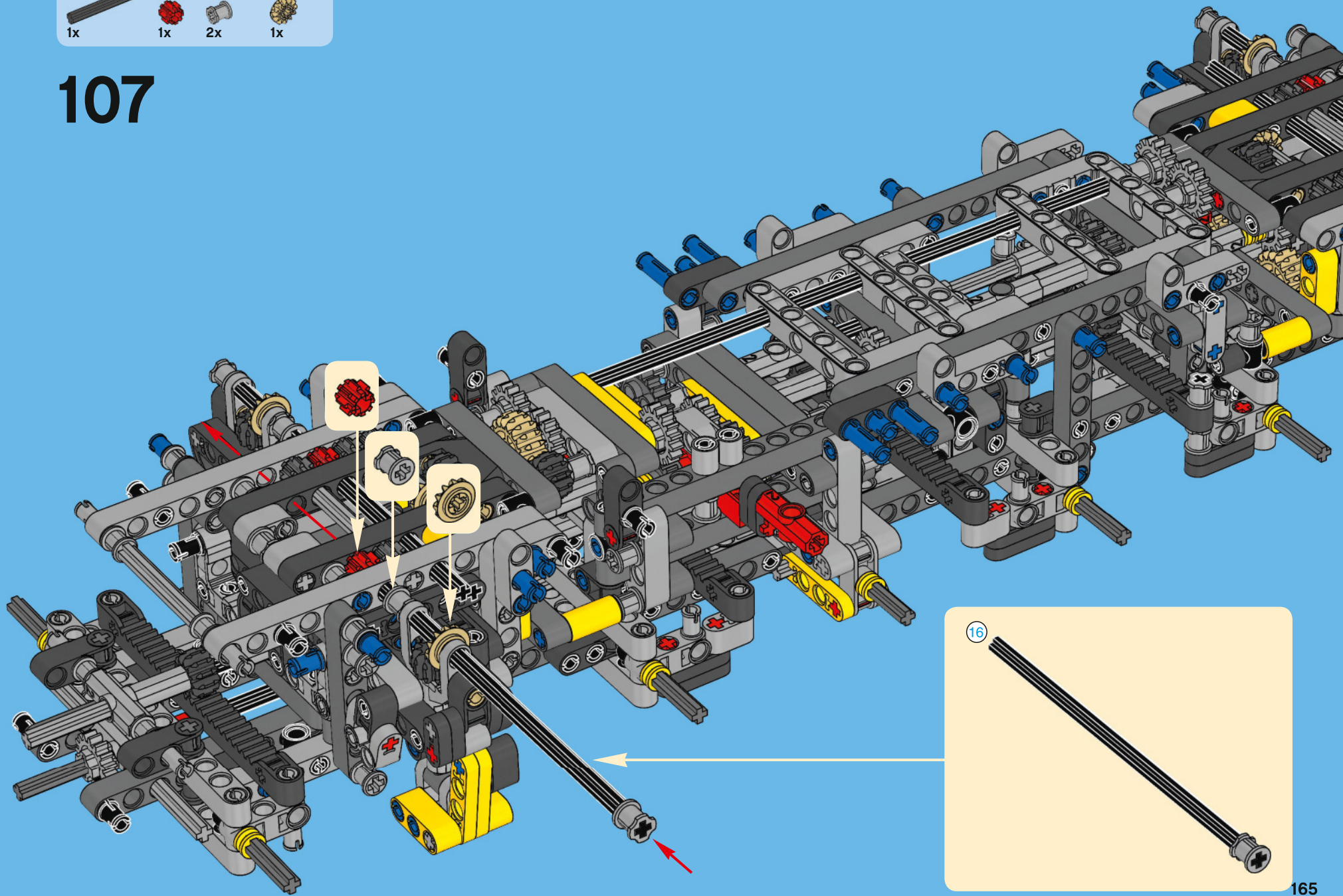



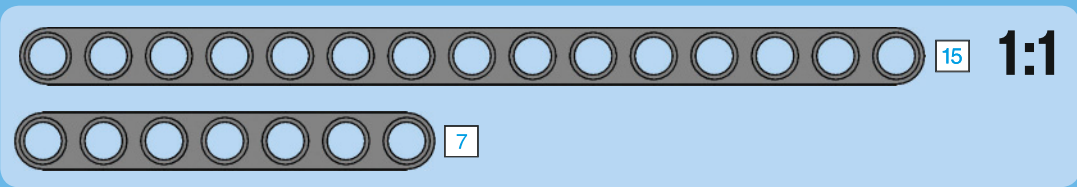
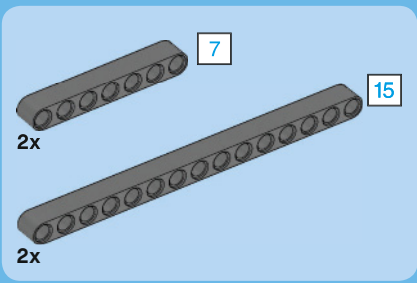

# 108

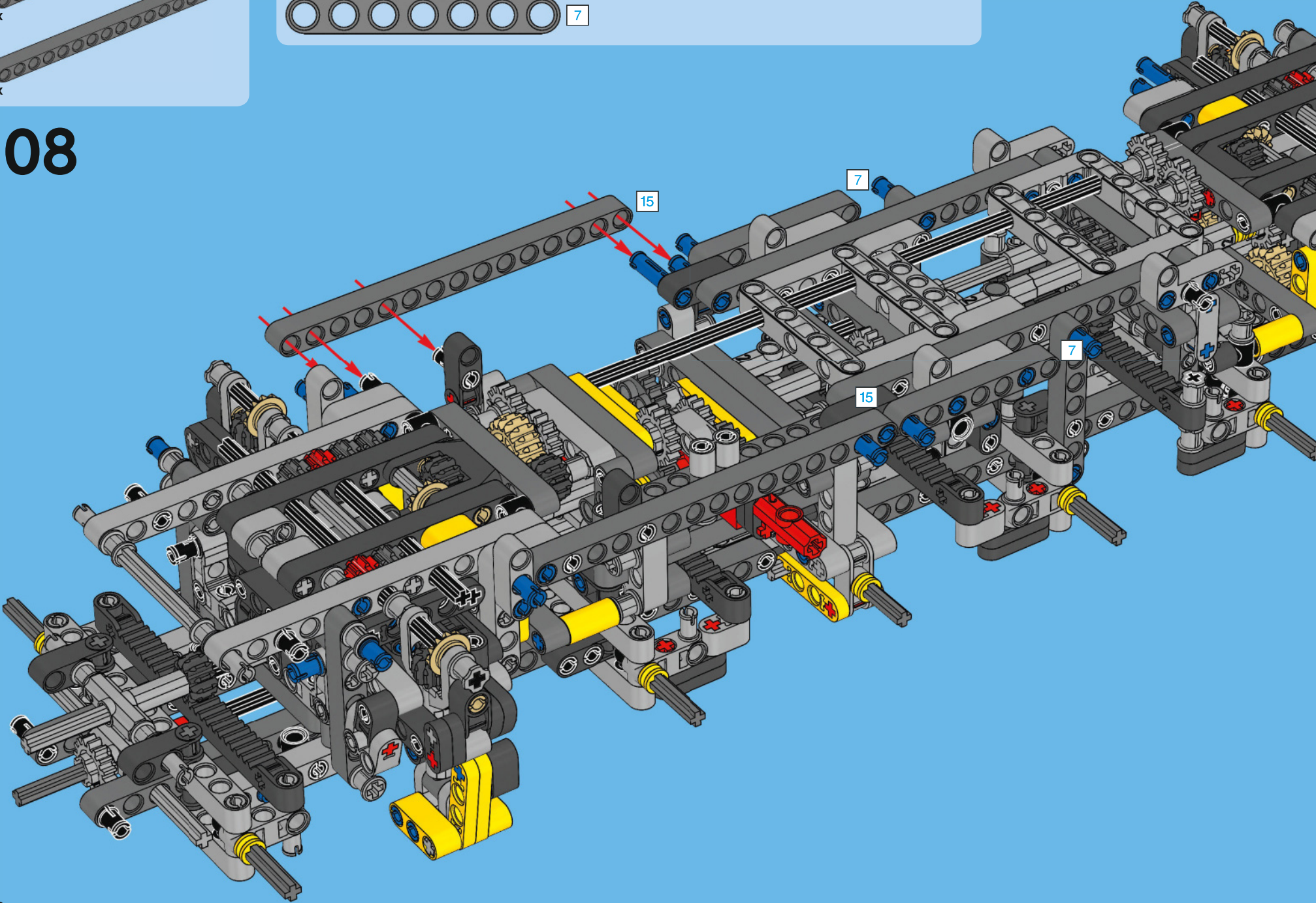





4x



2x

# 109

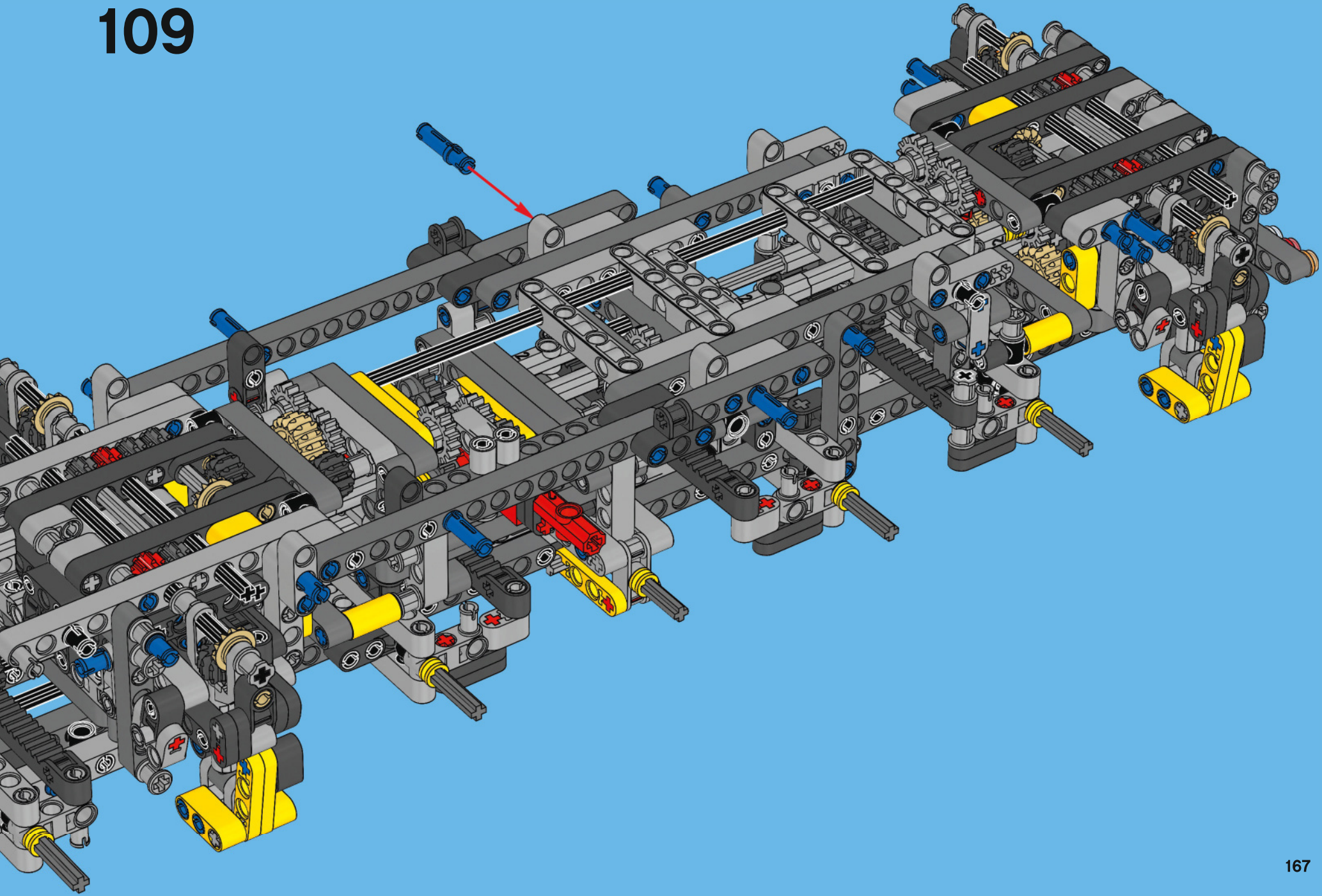



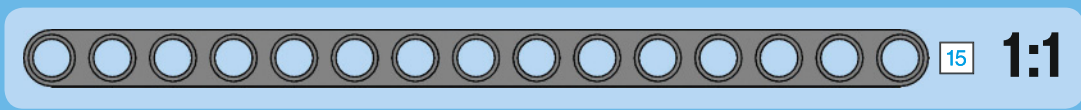
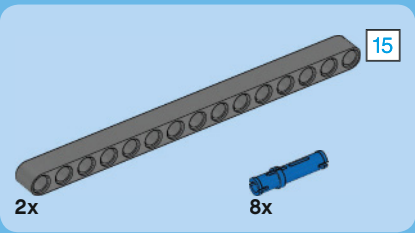

110

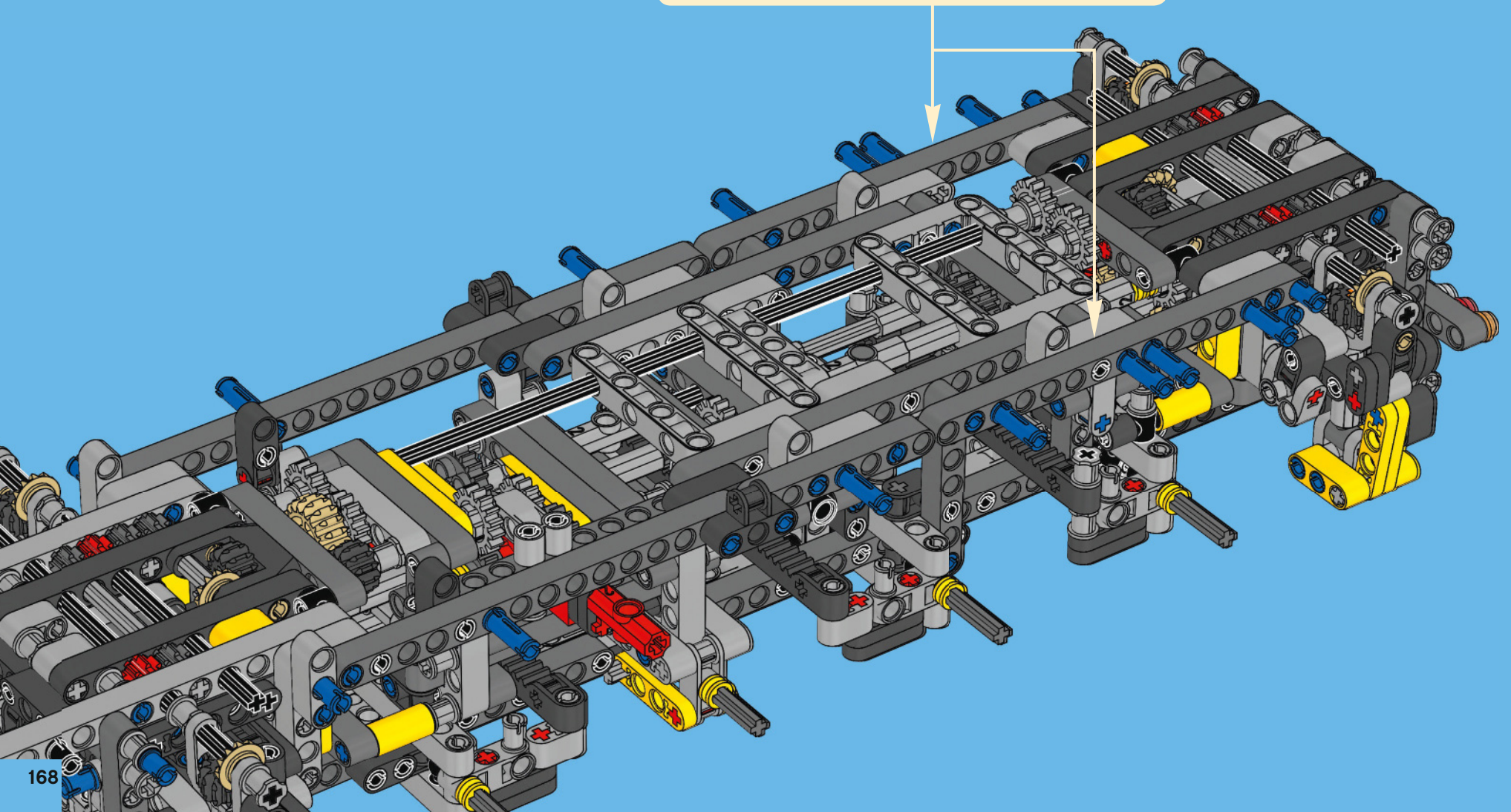
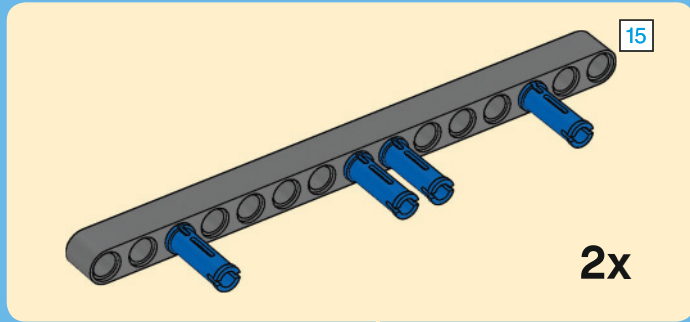





# 111

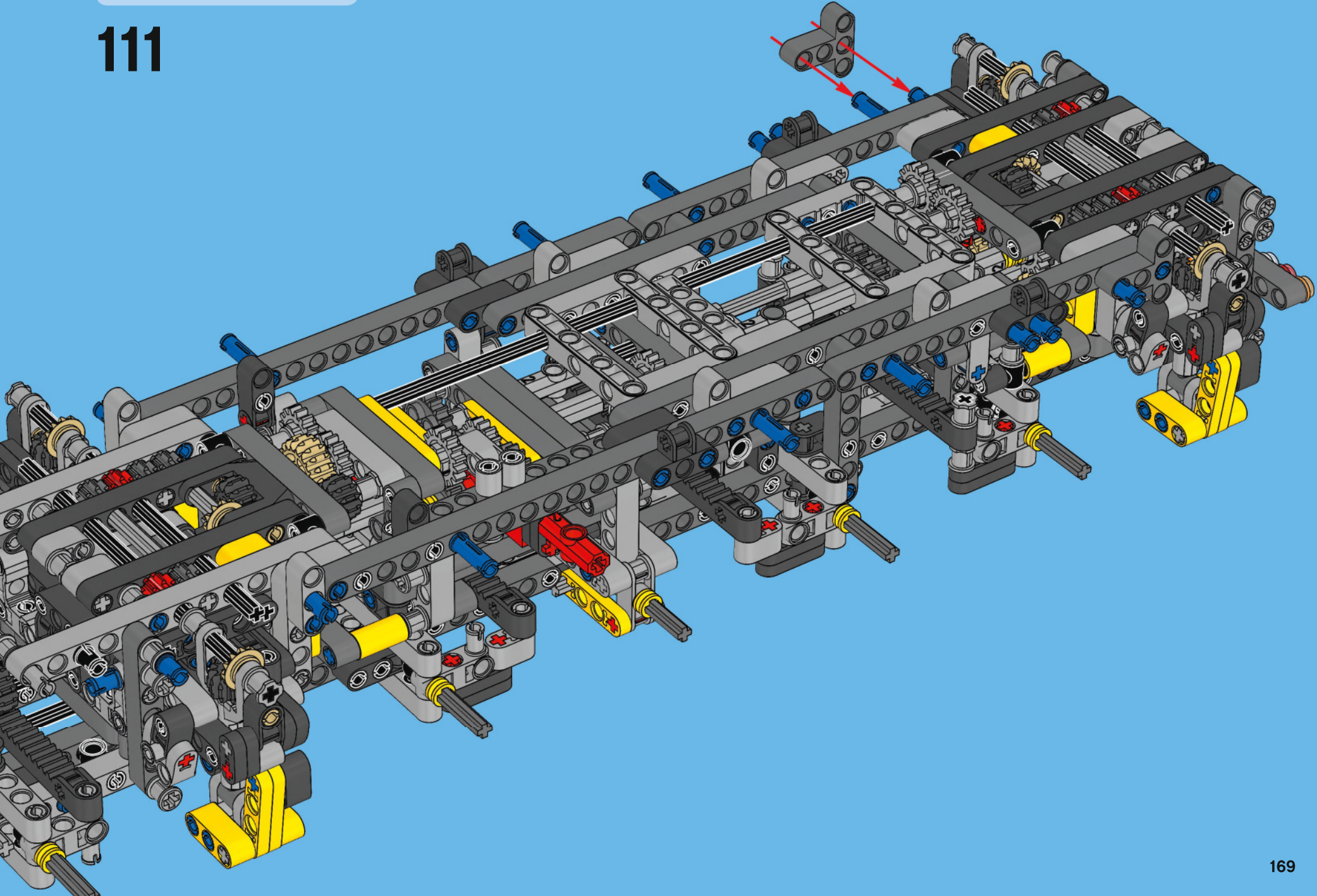



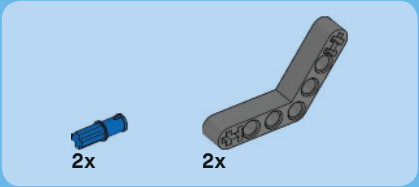

112

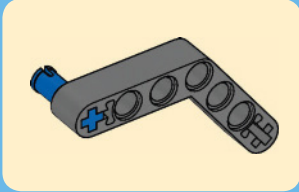
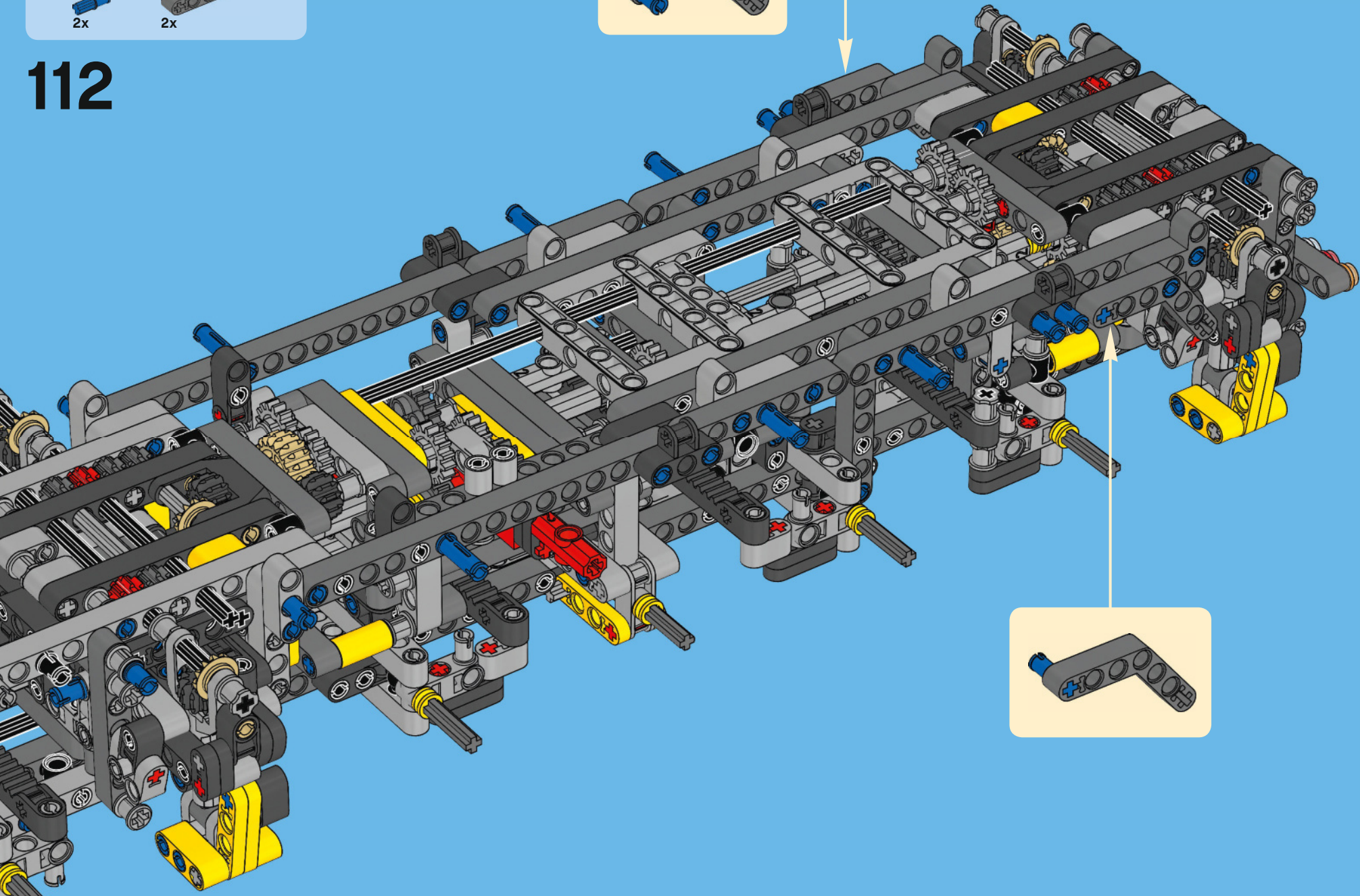
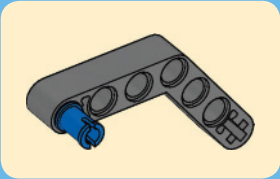



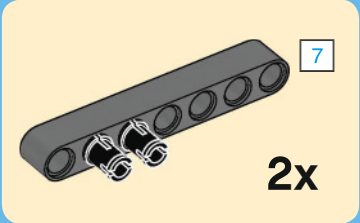
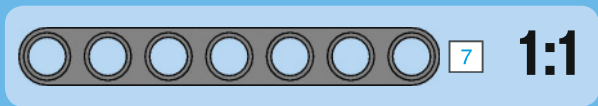
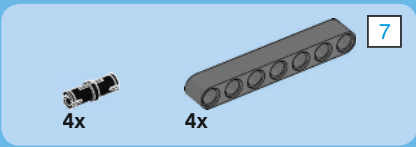

# 113

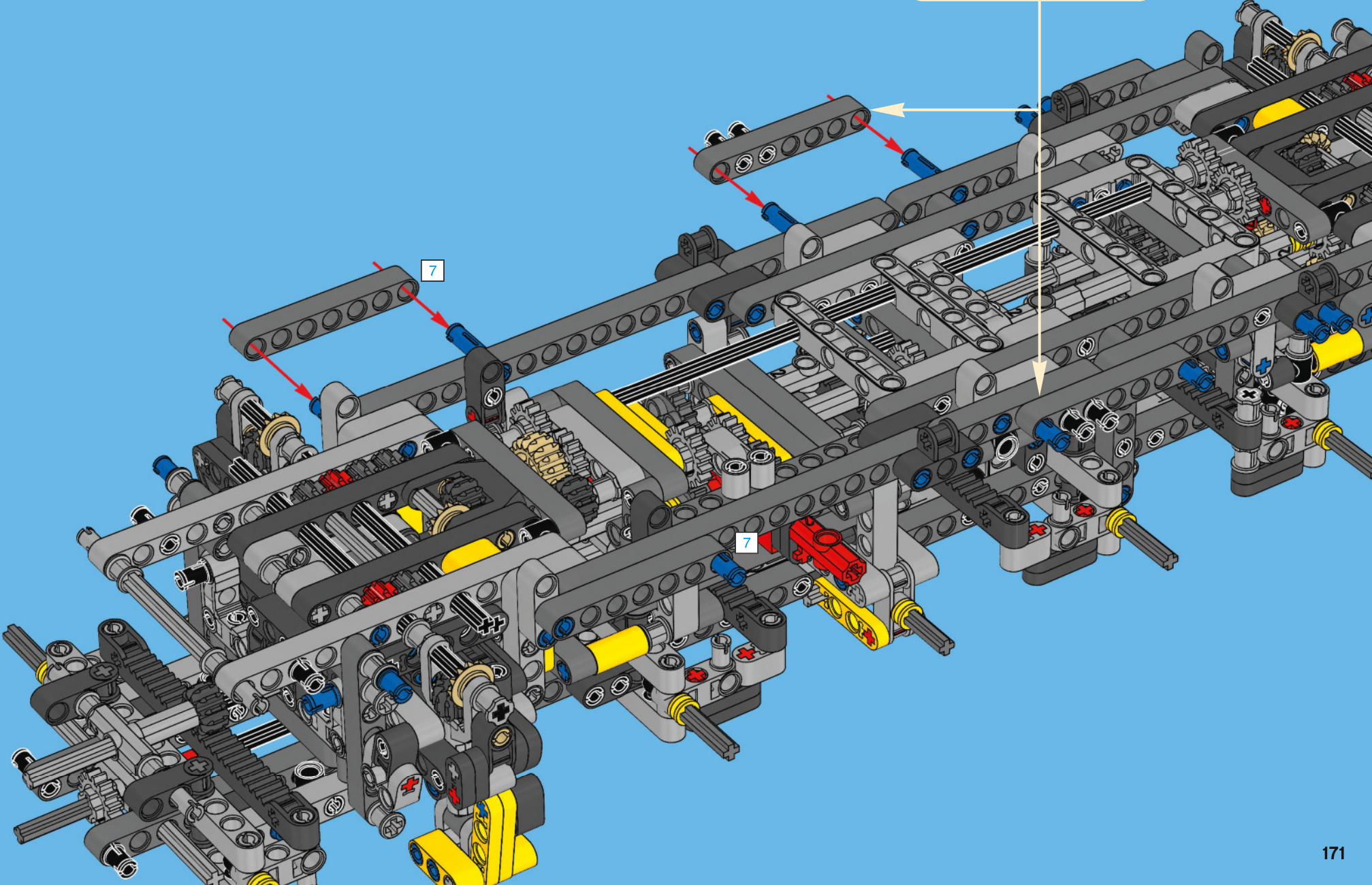



# 114

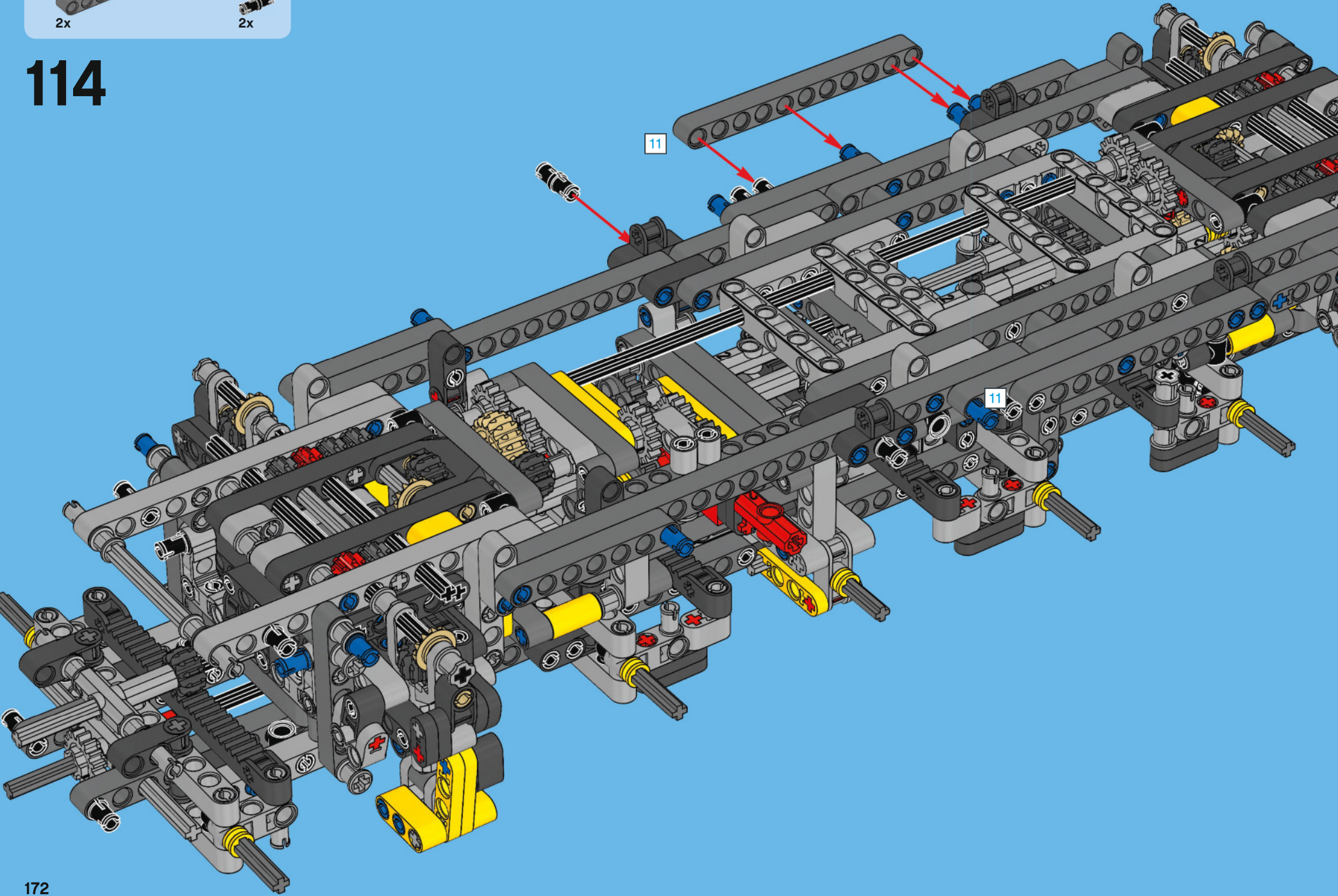
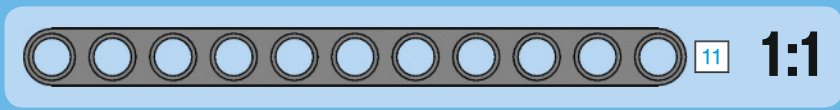
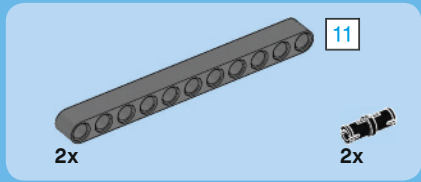



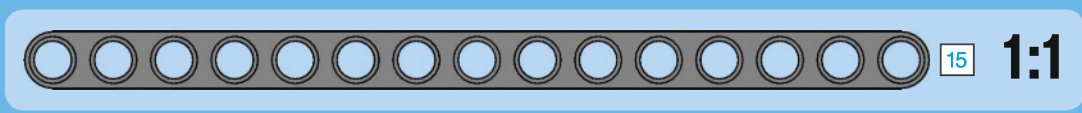
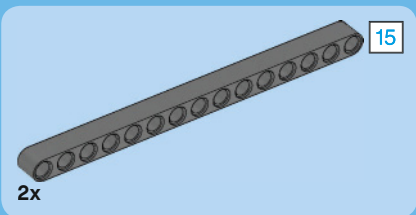

115

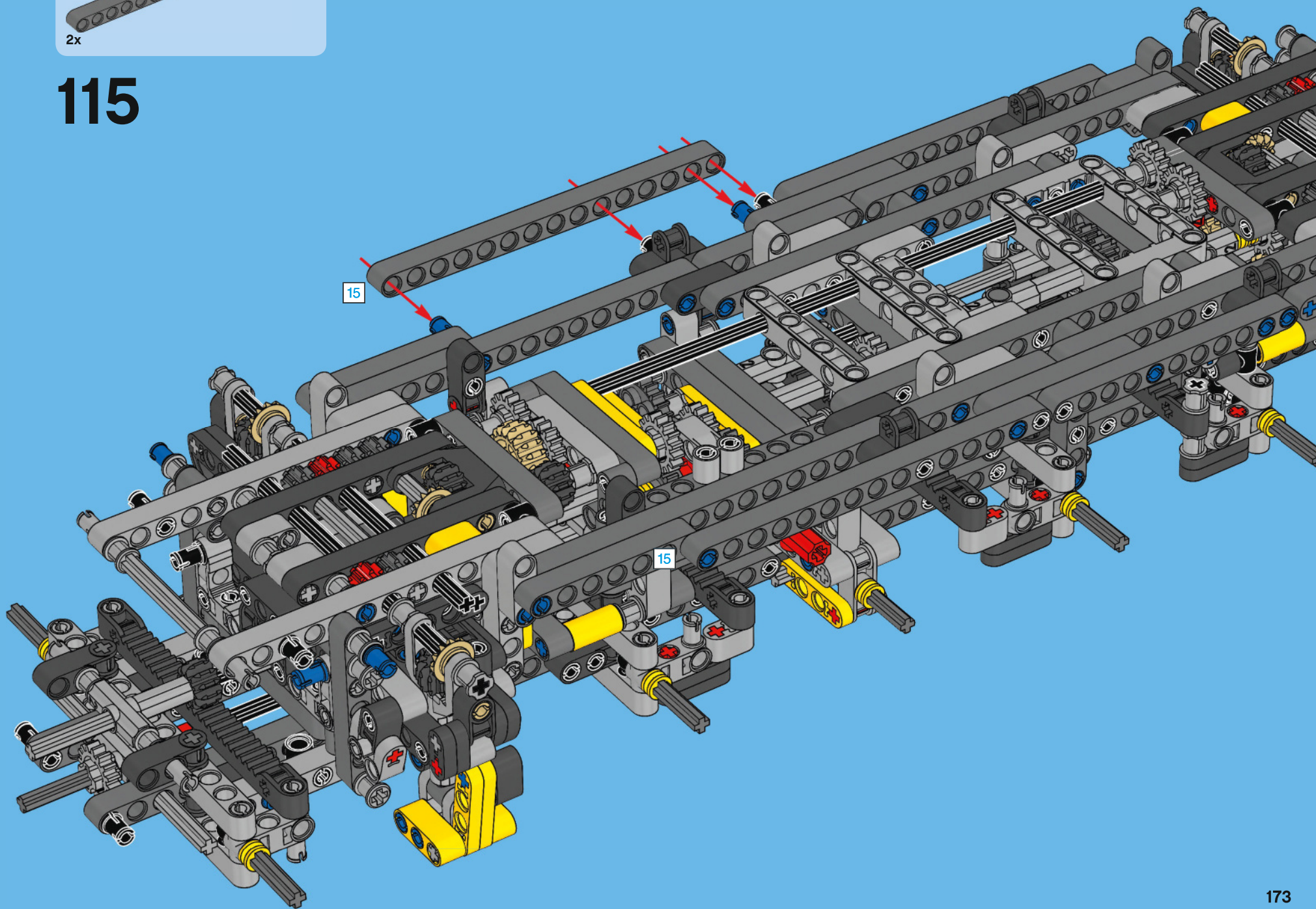



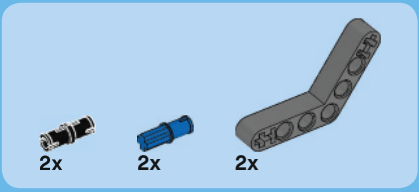

# 116

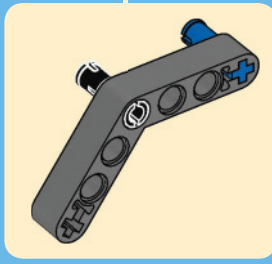
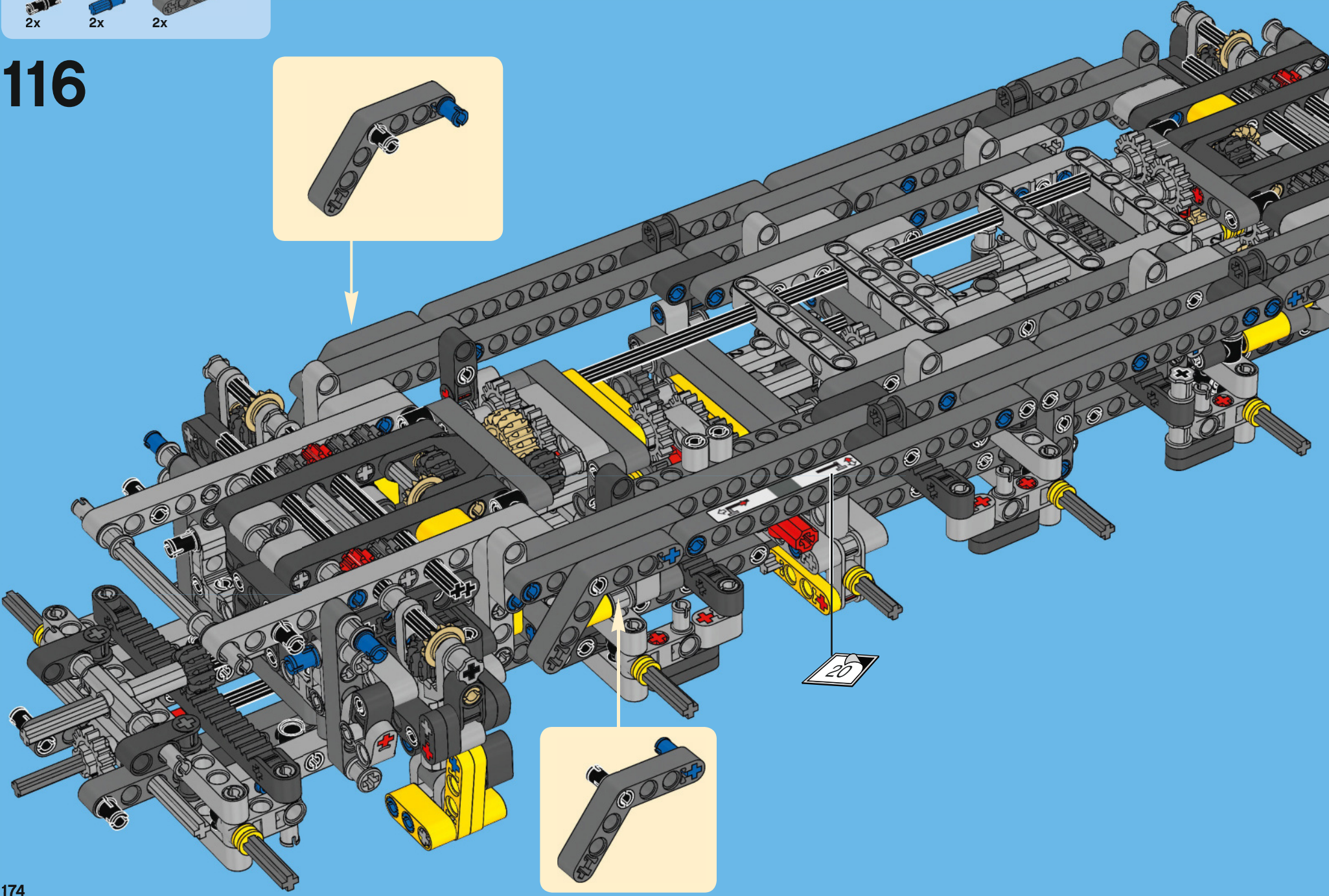
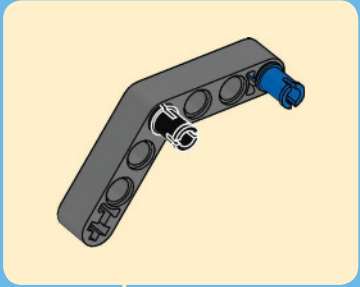

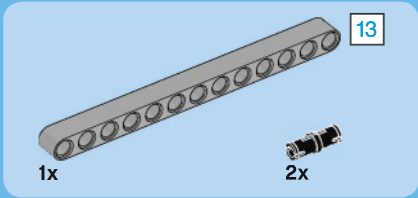
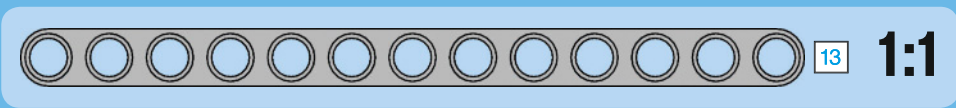
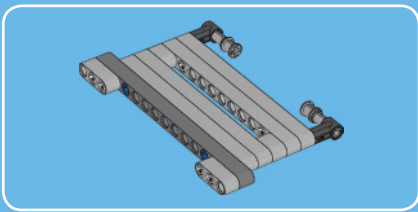

1

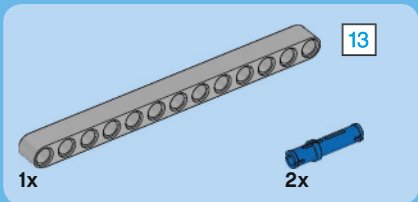
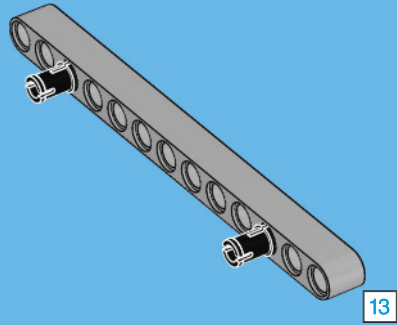

2

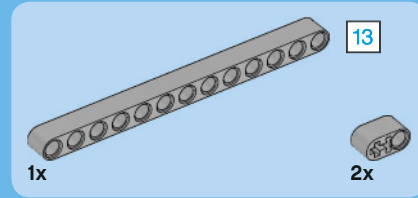
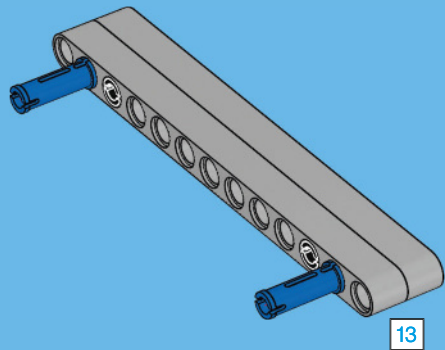

3

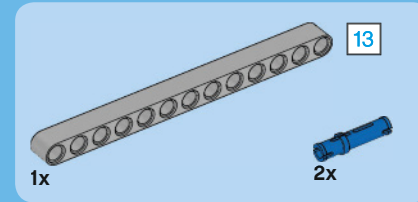
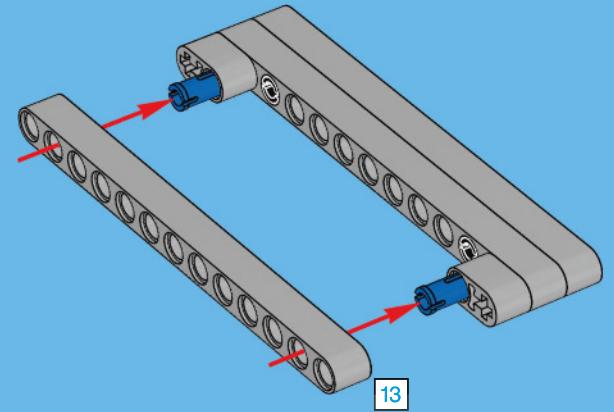

4

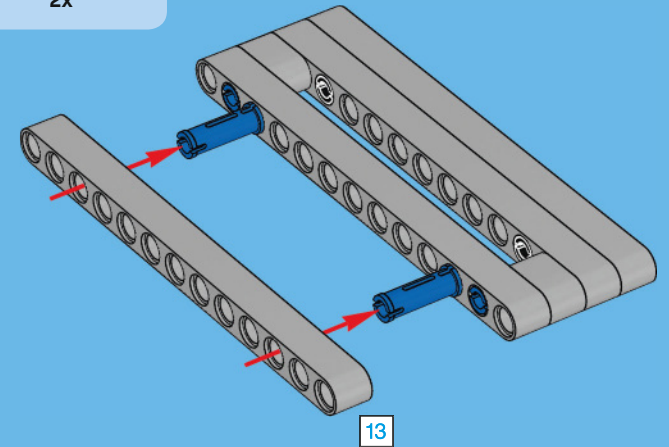



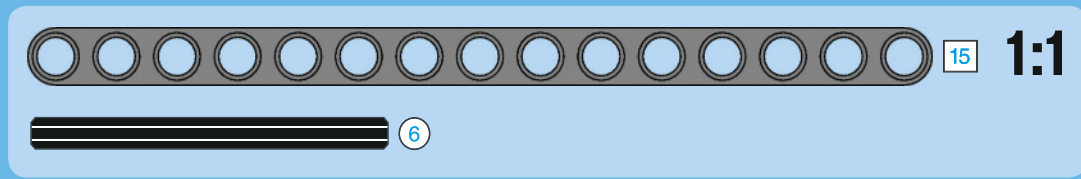
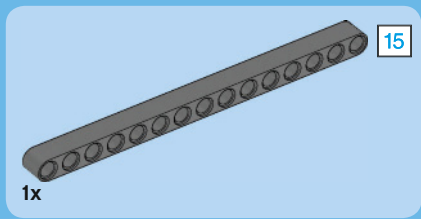

5

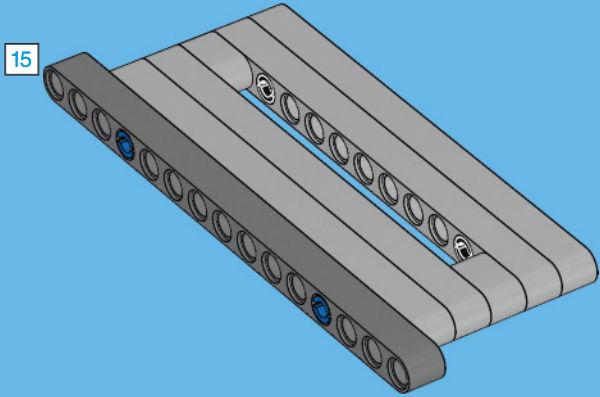

6

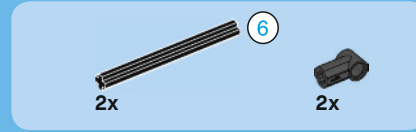
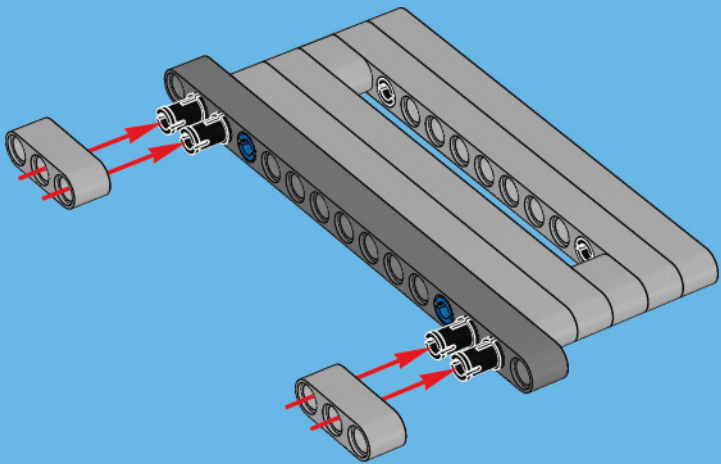

7

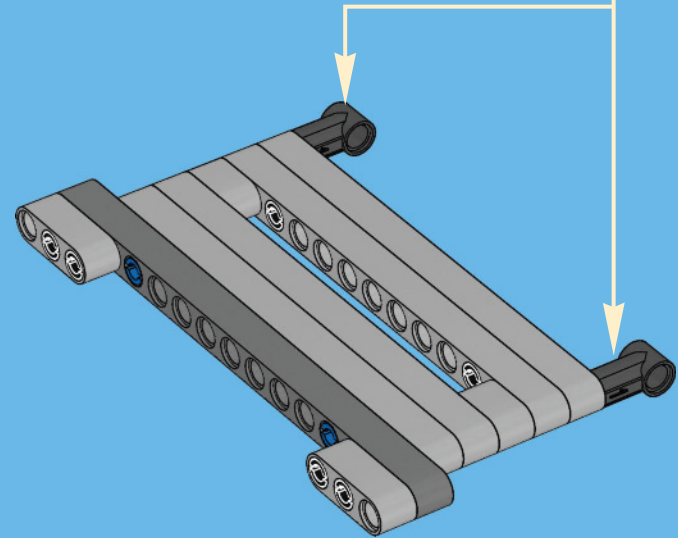
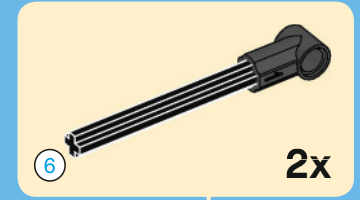



2x

8

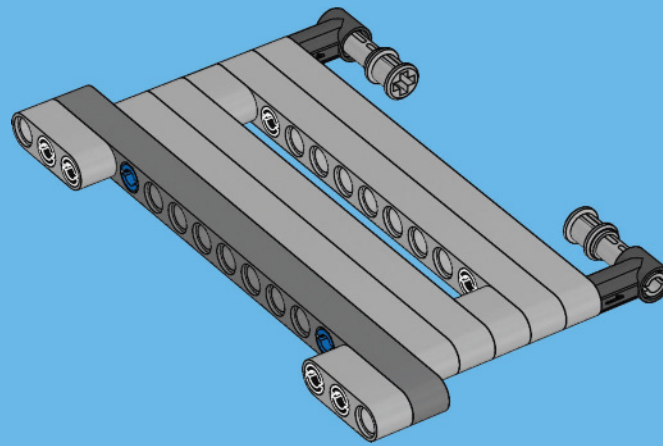

117

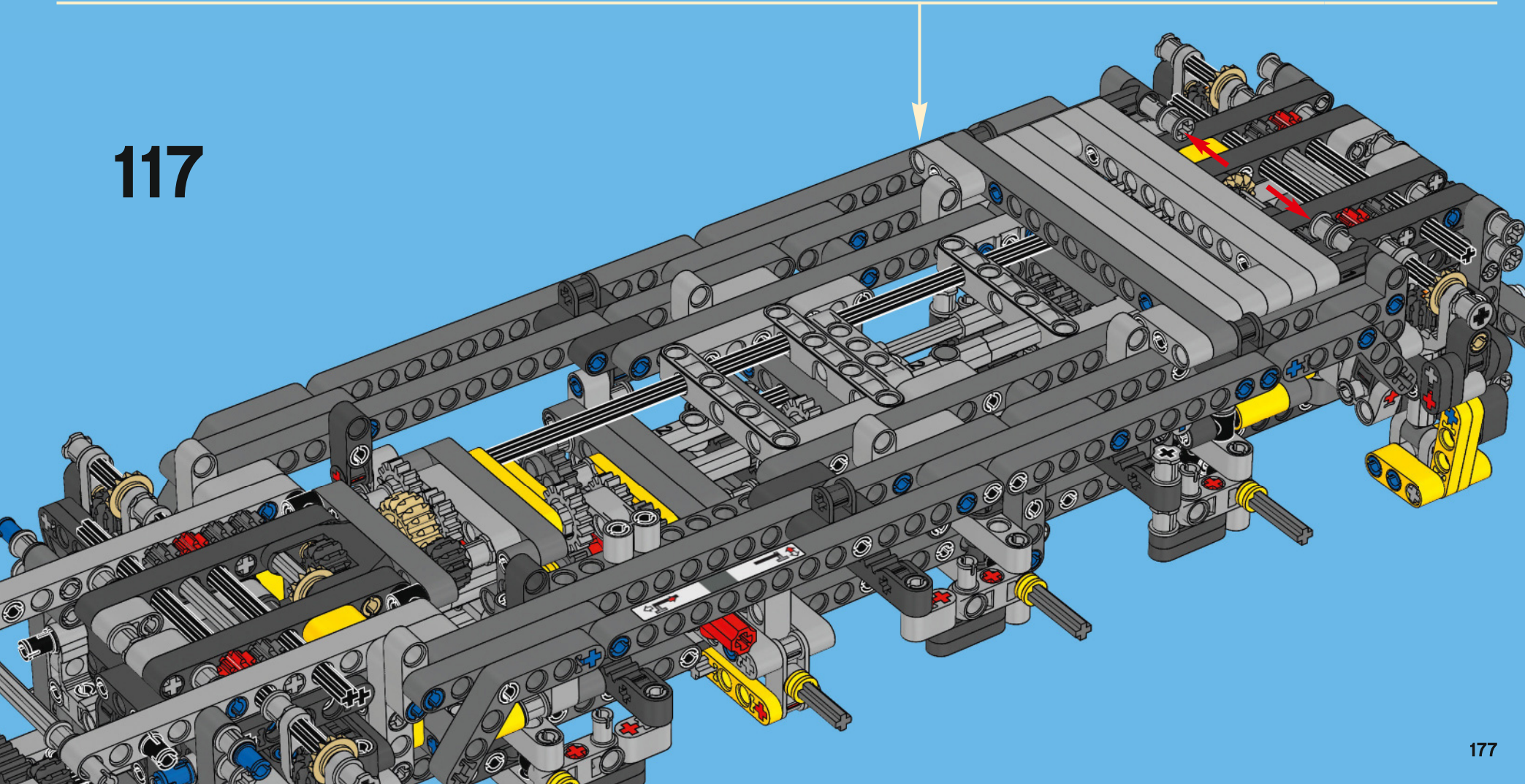



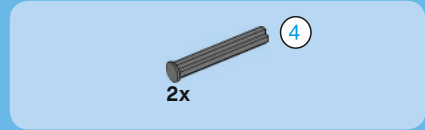

118

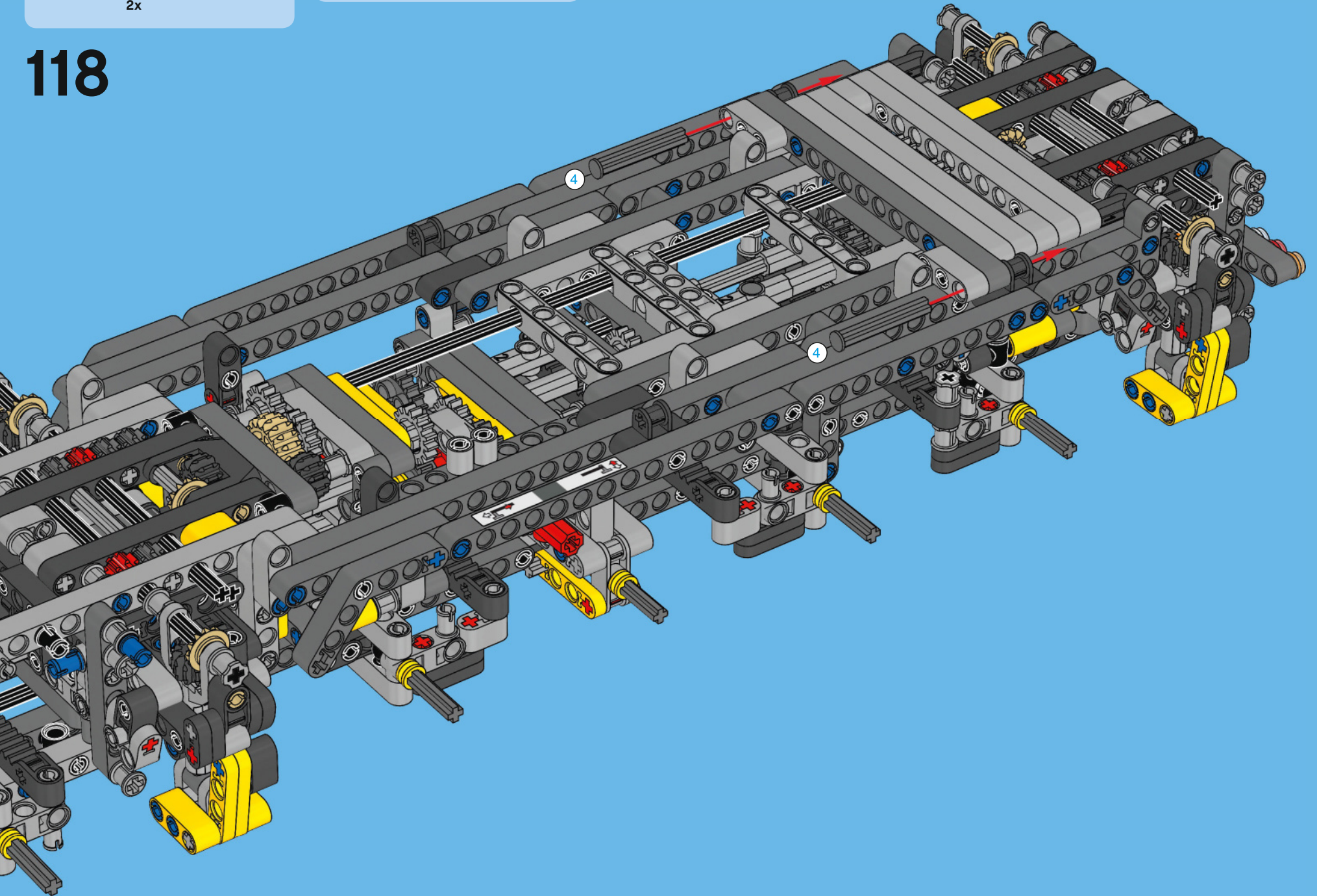



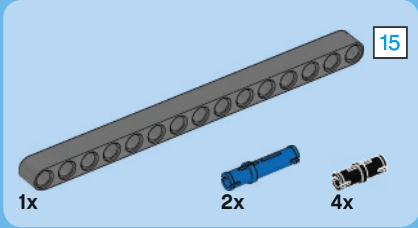
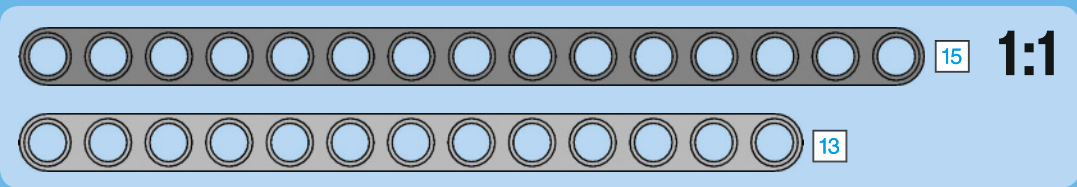
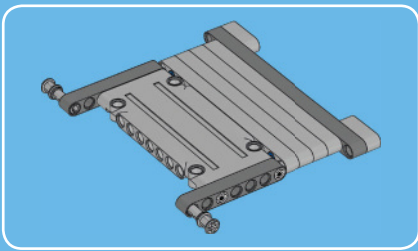

1

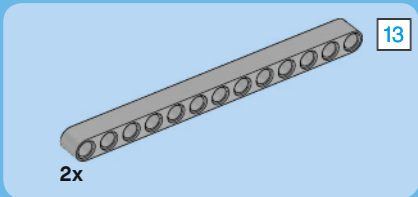
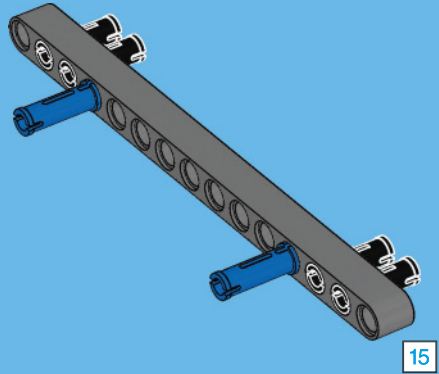

2

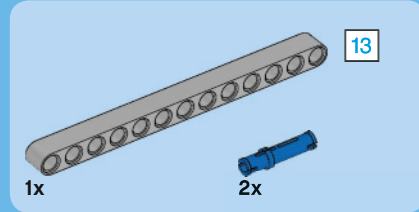
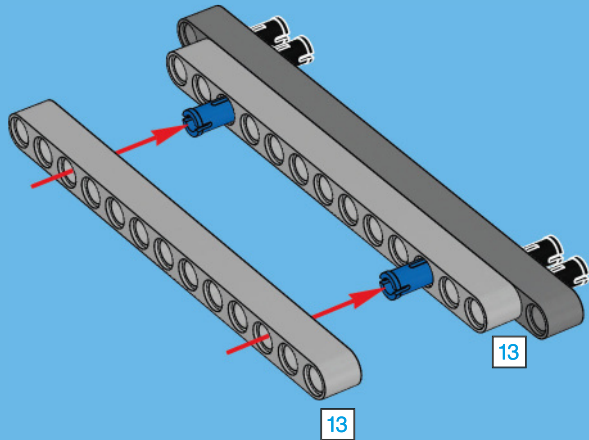

3

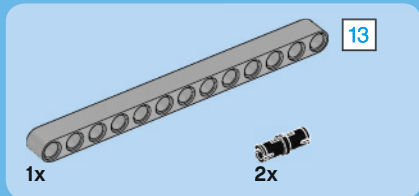
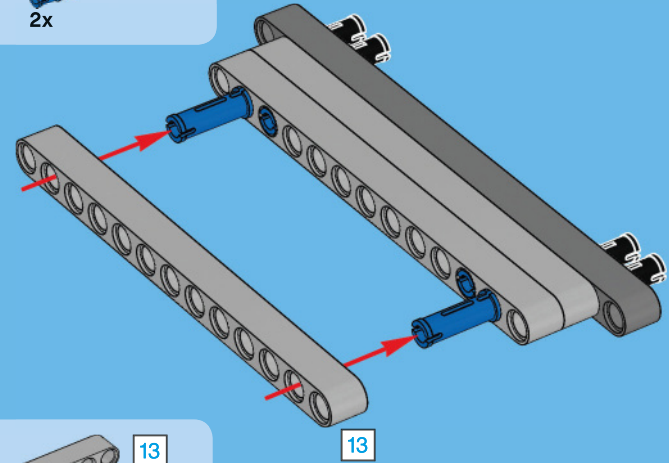

4

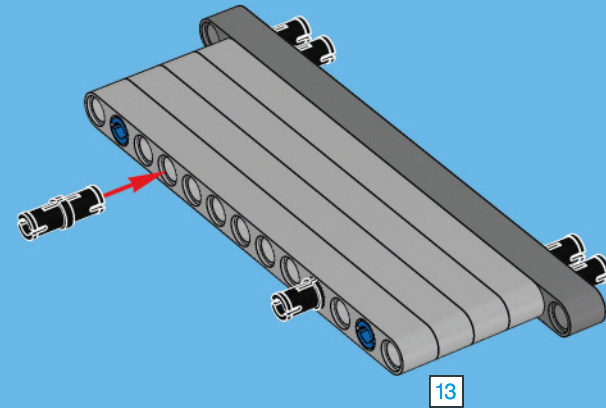

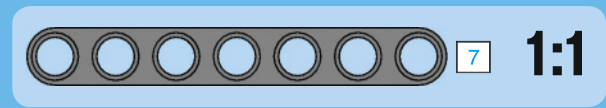
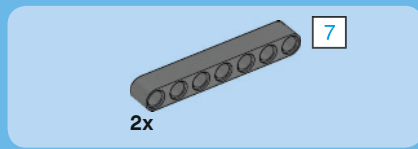
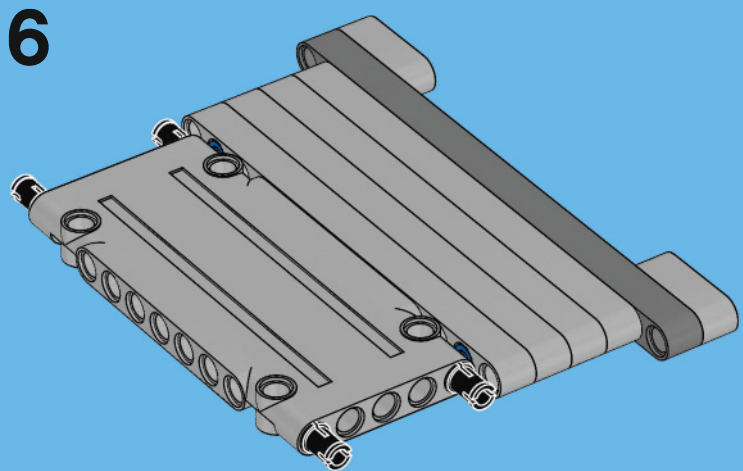
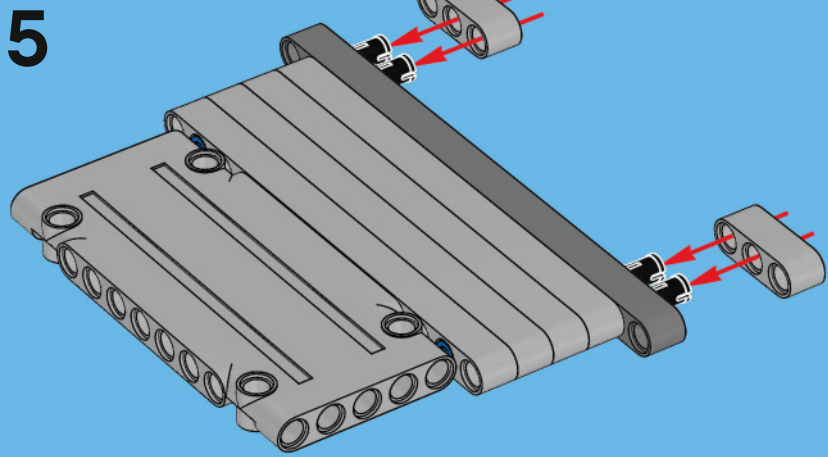
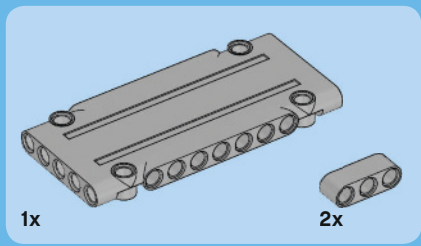

7

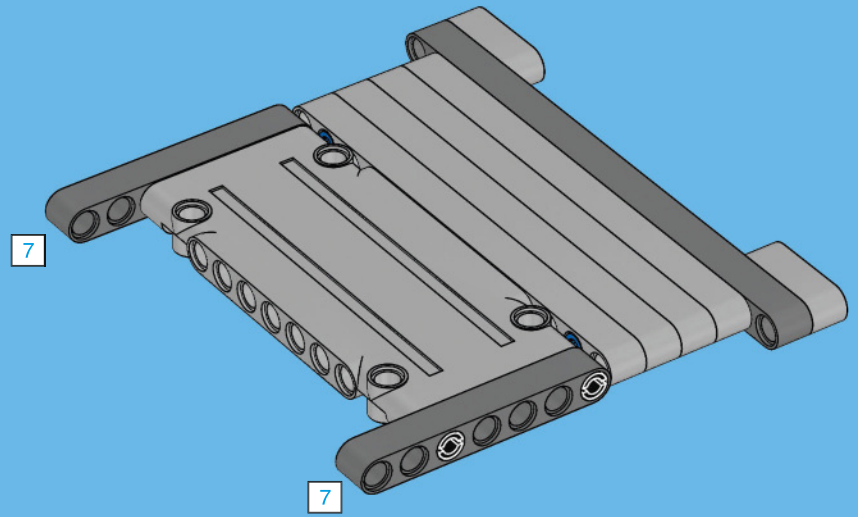

8

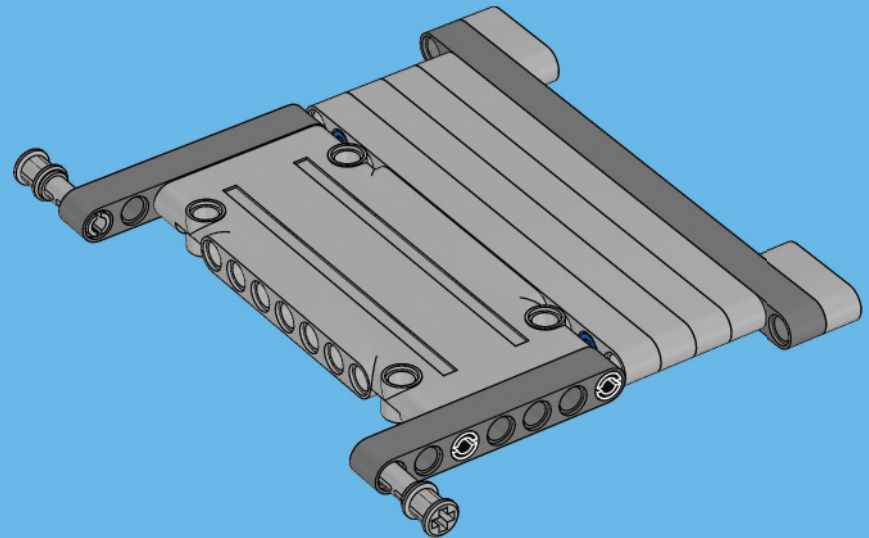



# 119

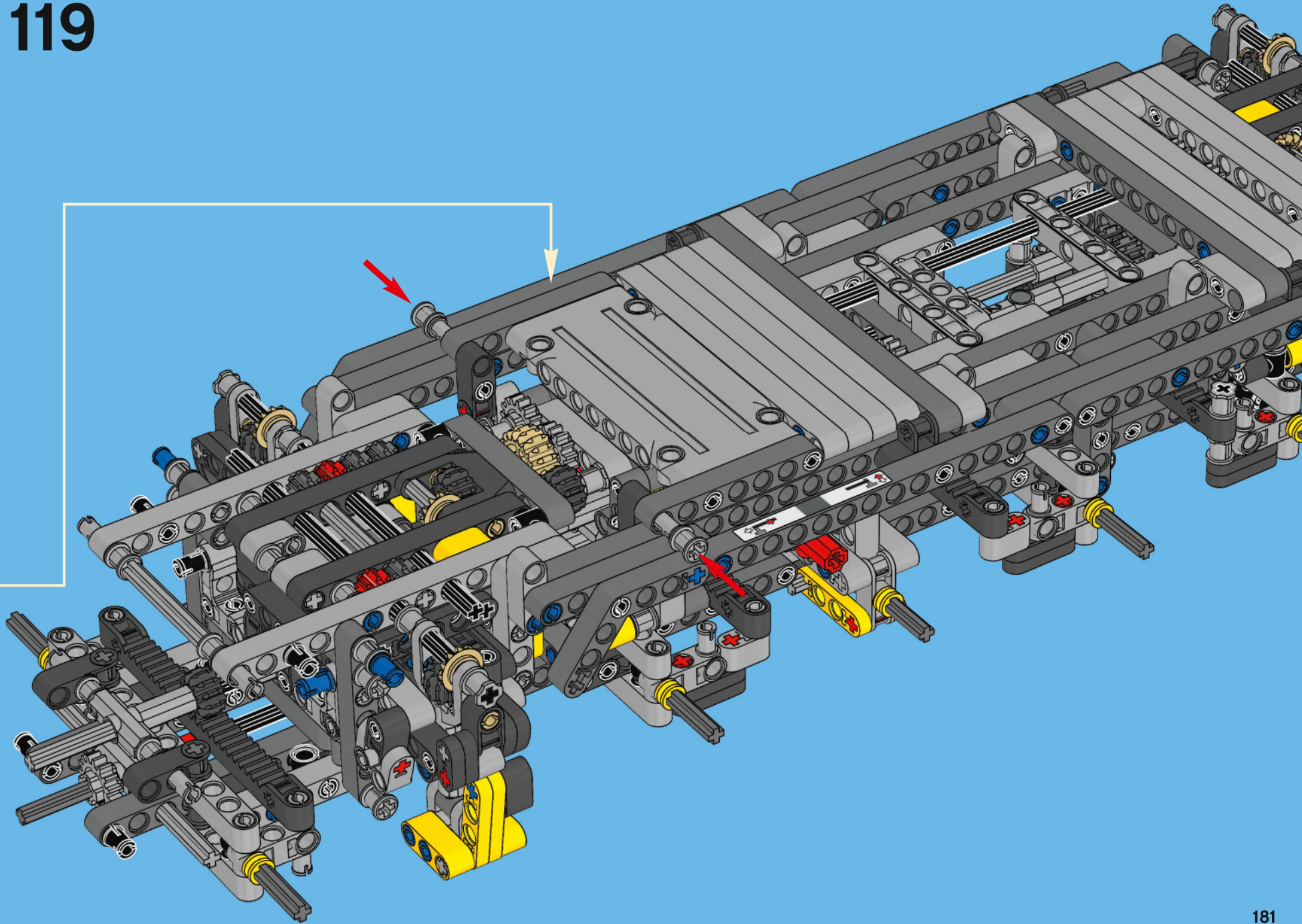



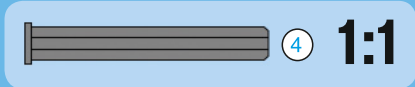
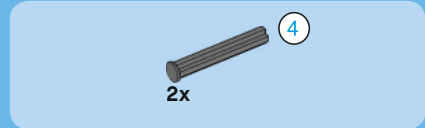

120

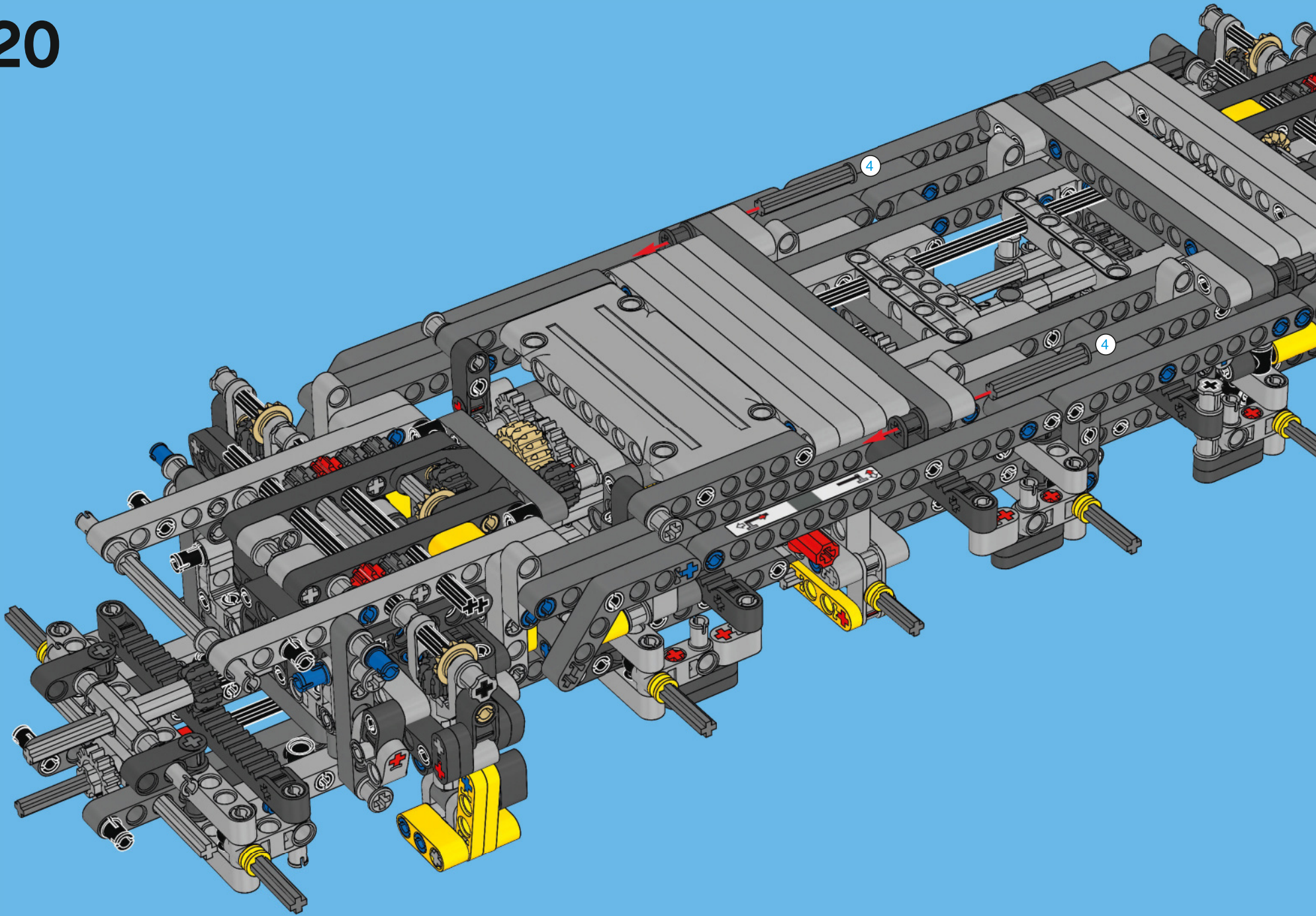



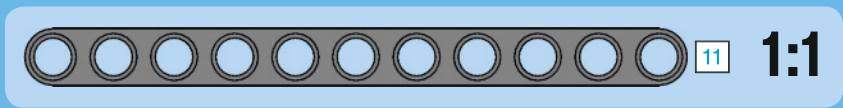
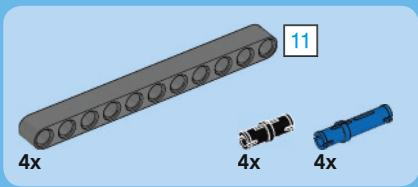

121

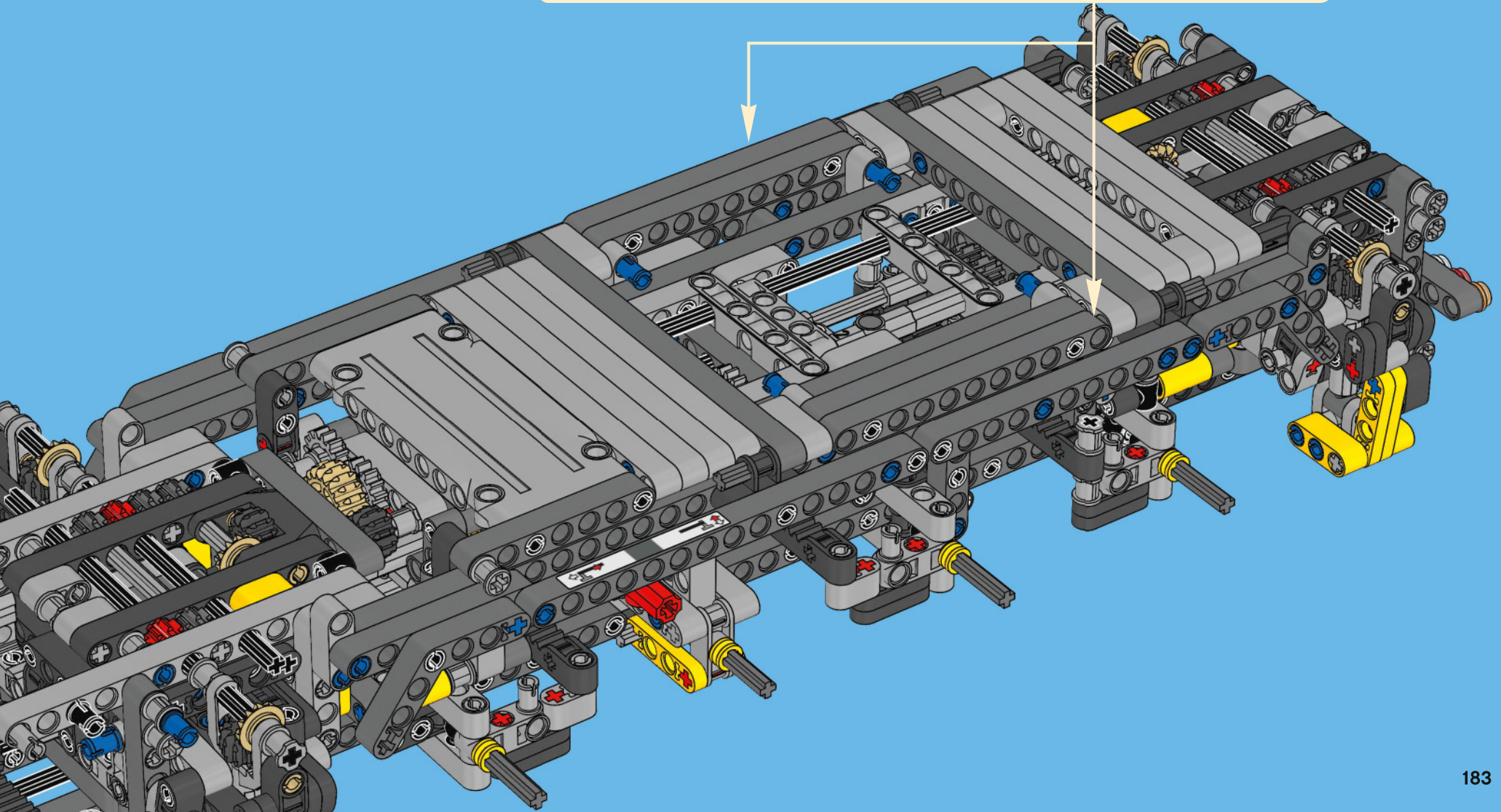
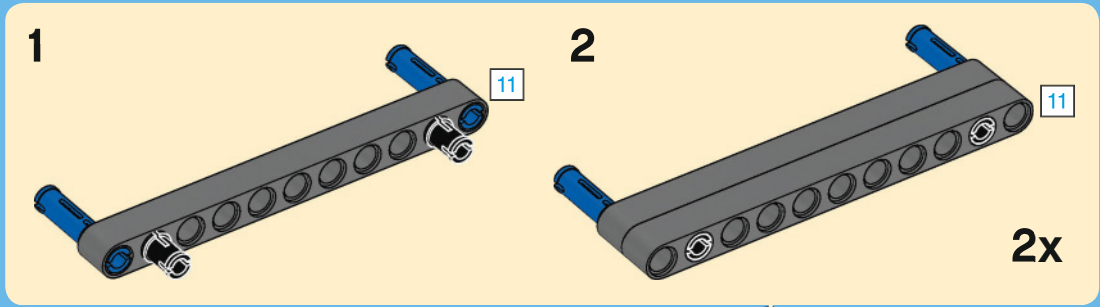





4x



2x

# 122

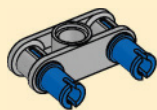

2x

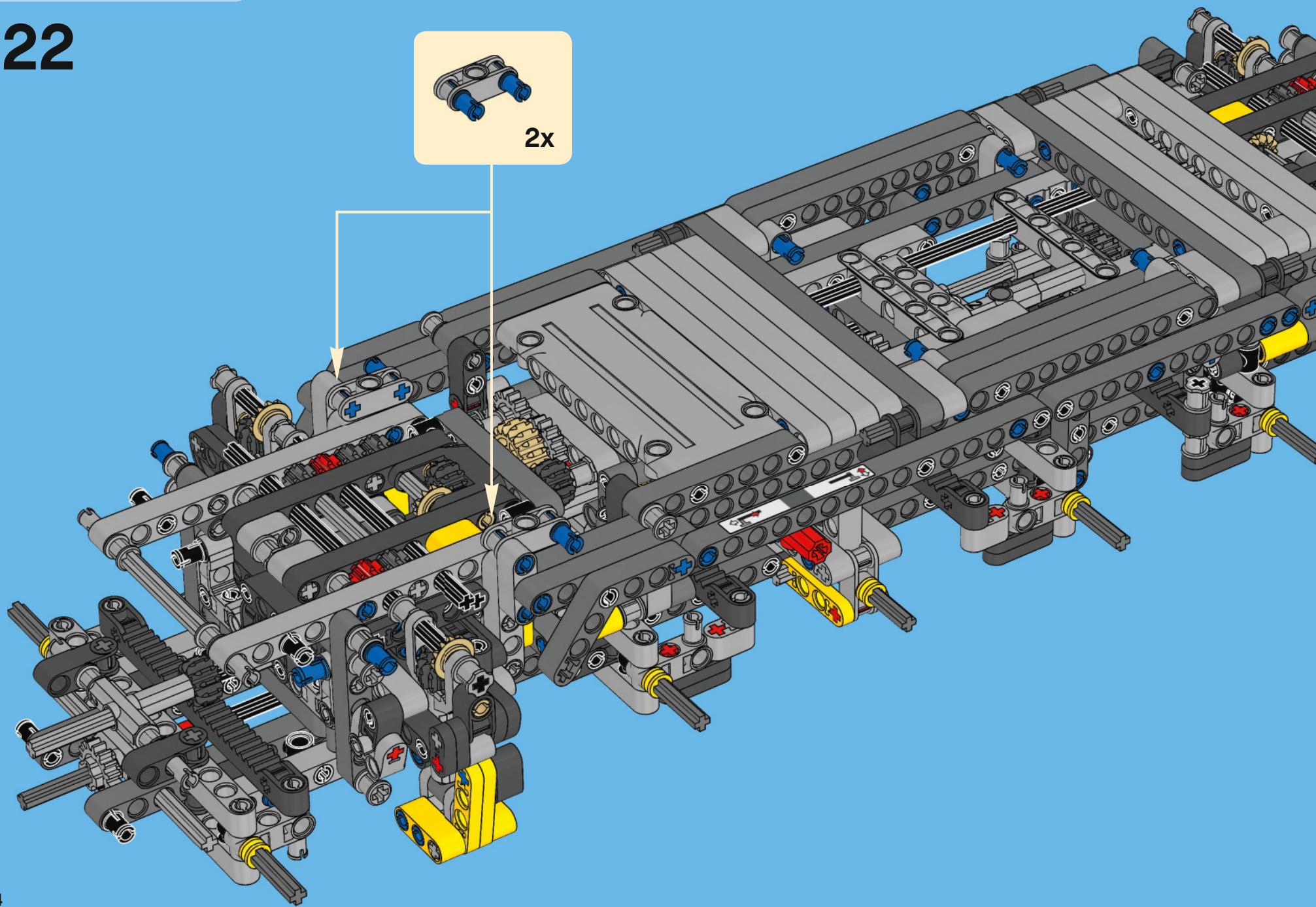



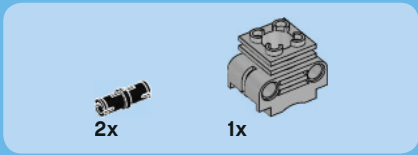
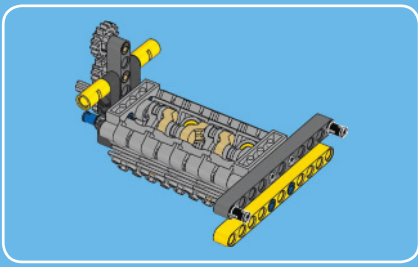

1

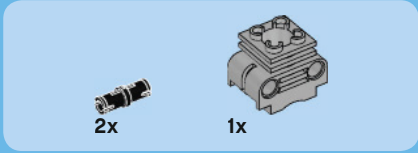
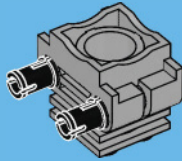

2

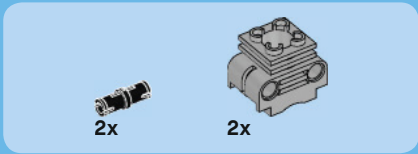
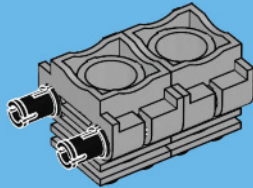

3

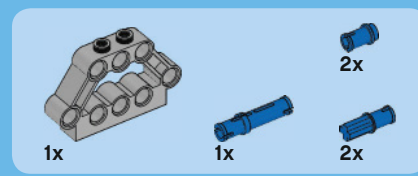
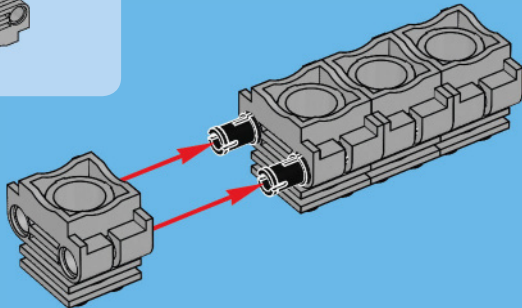

4

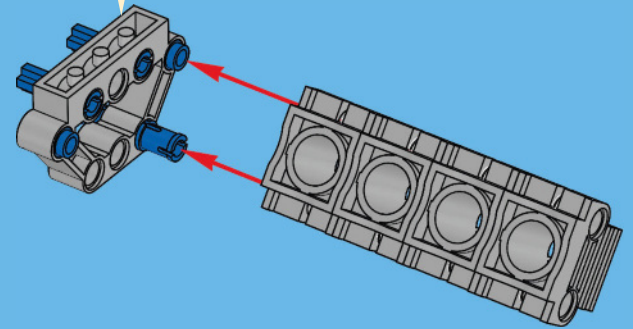
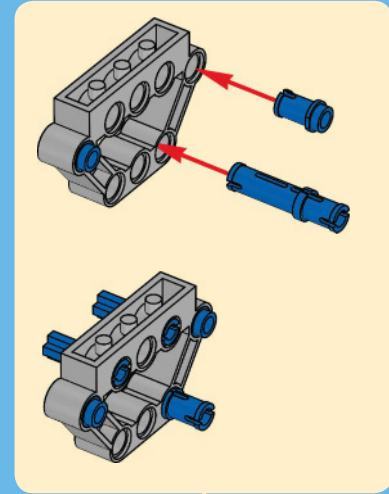

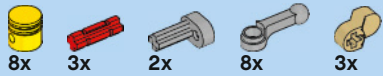

5

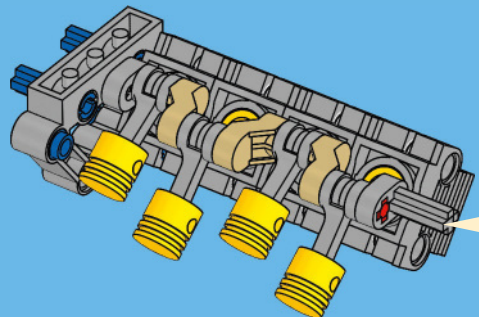
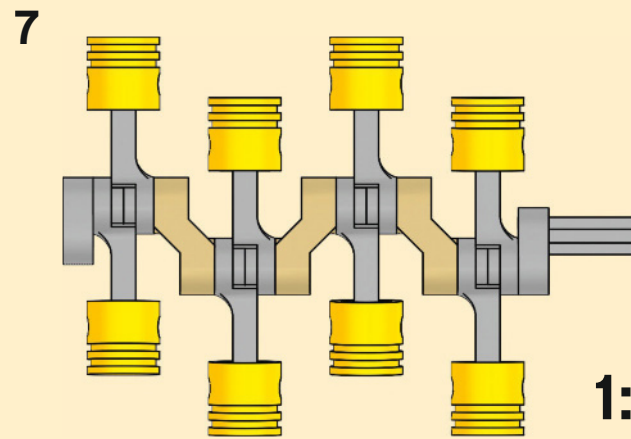
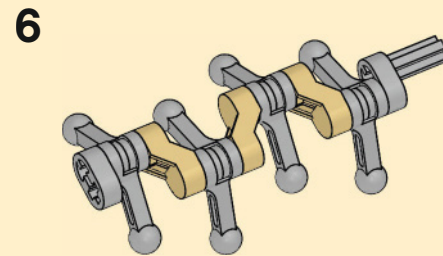
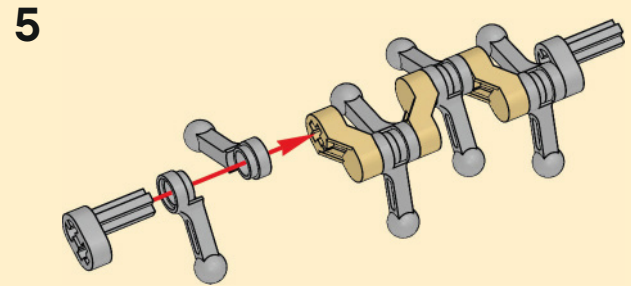
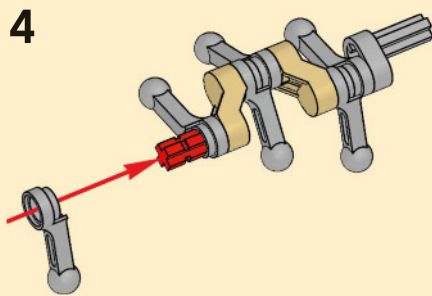
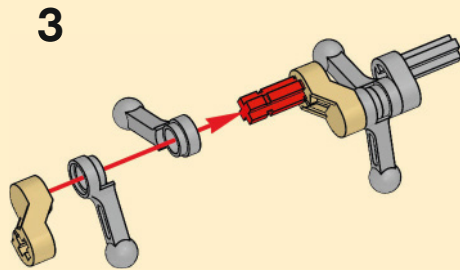
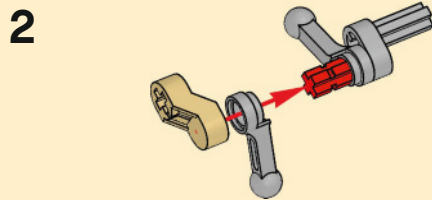
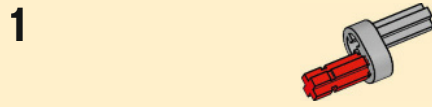



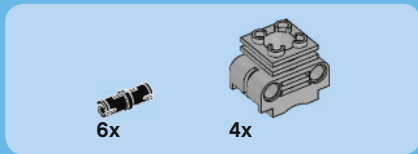
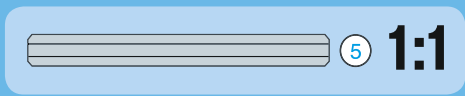
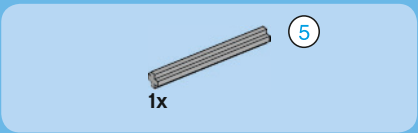

6

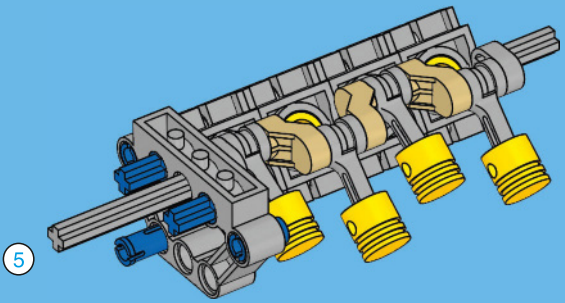

7

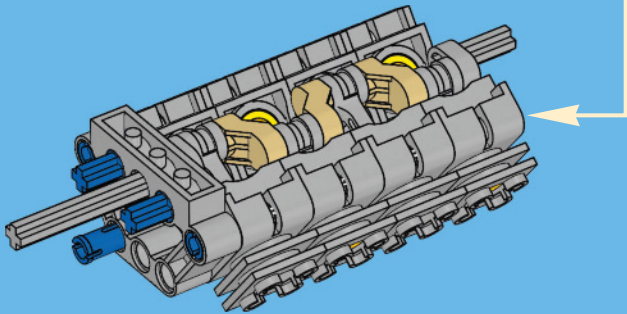
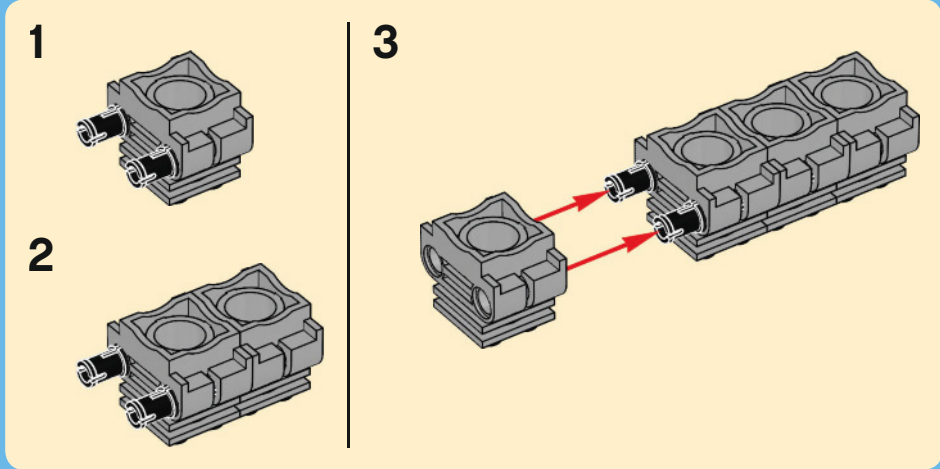



1x

8

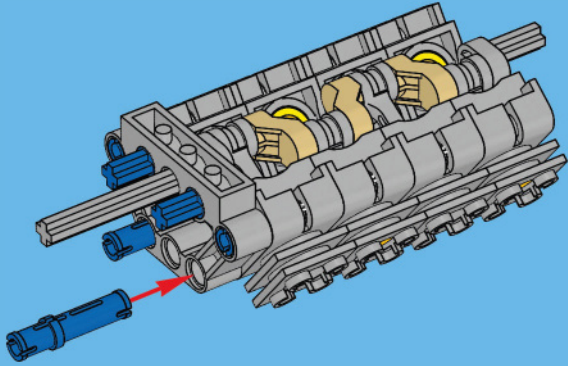

2x

9

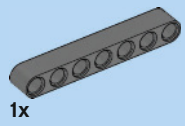
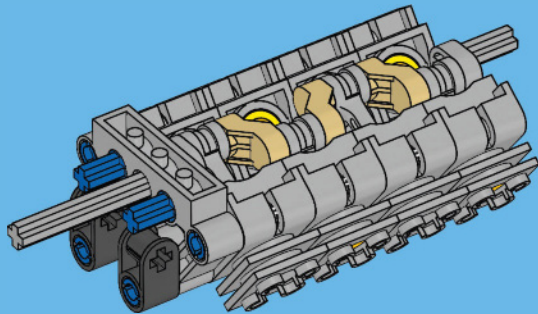

1x

7



1x

10

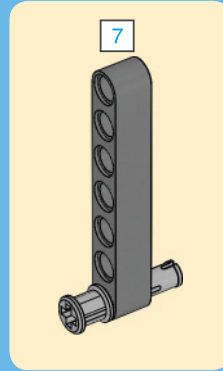

7



7

1:1

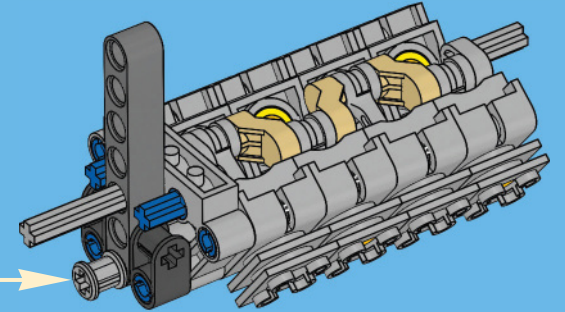

2x



2x

11

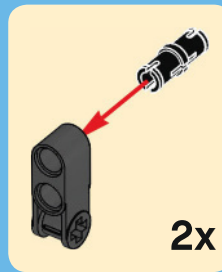

2x

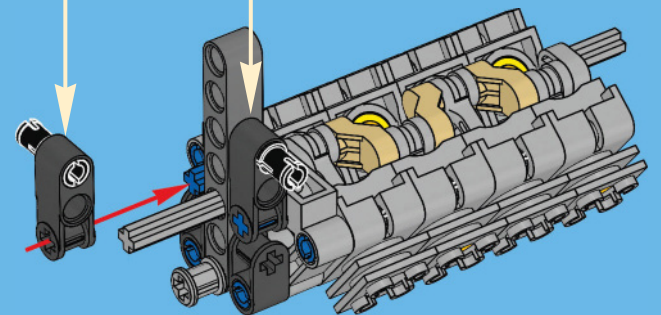

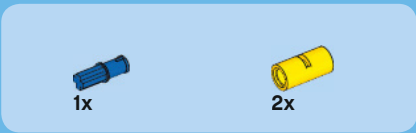

12

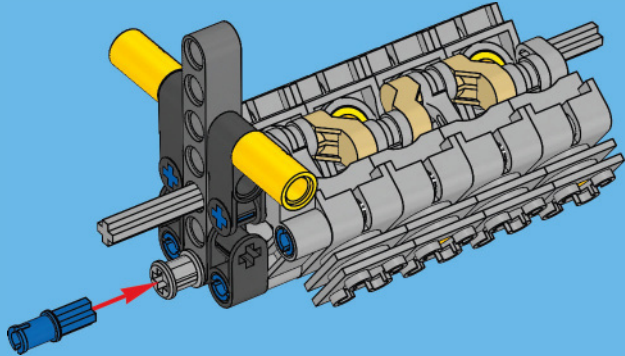

13

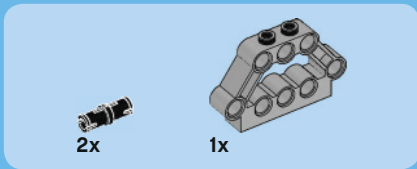
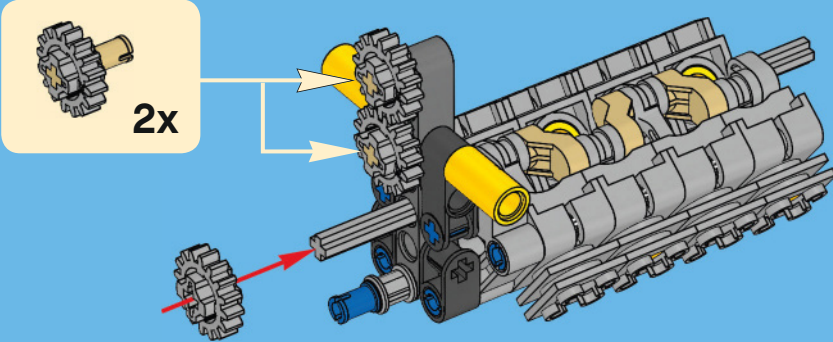

14

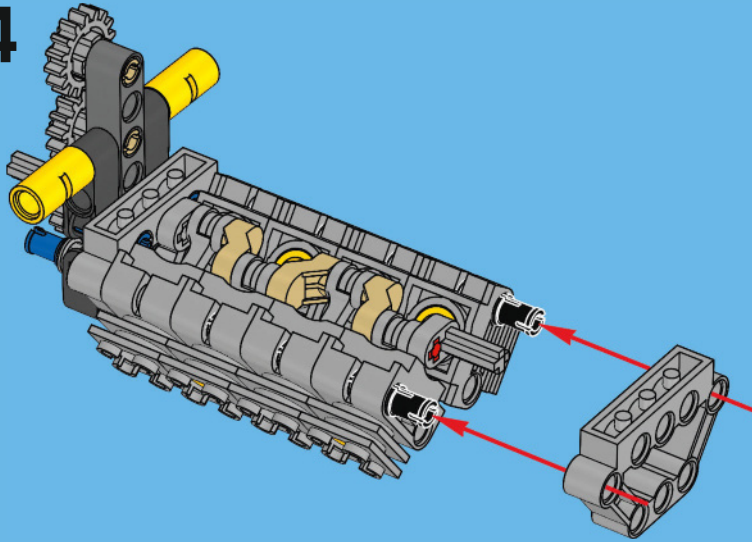

15

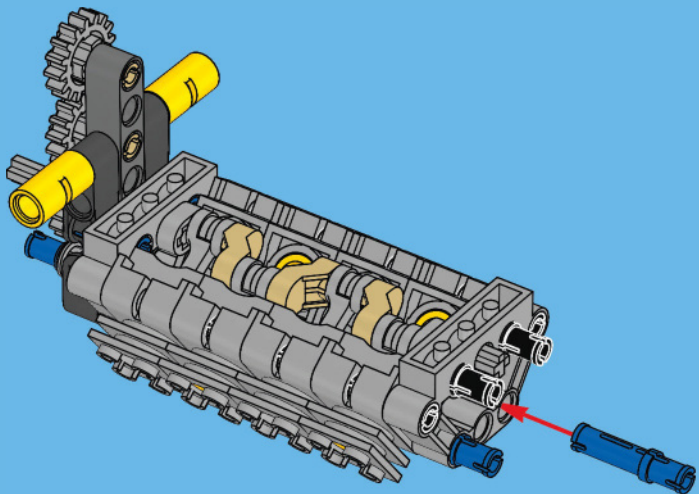



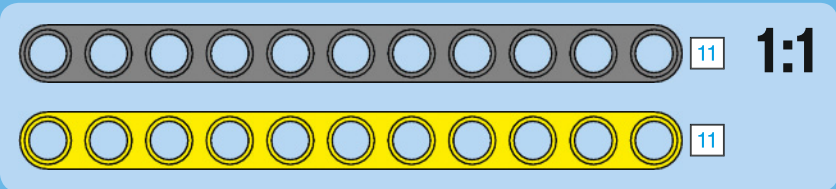
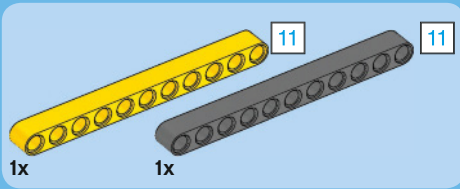

# 16

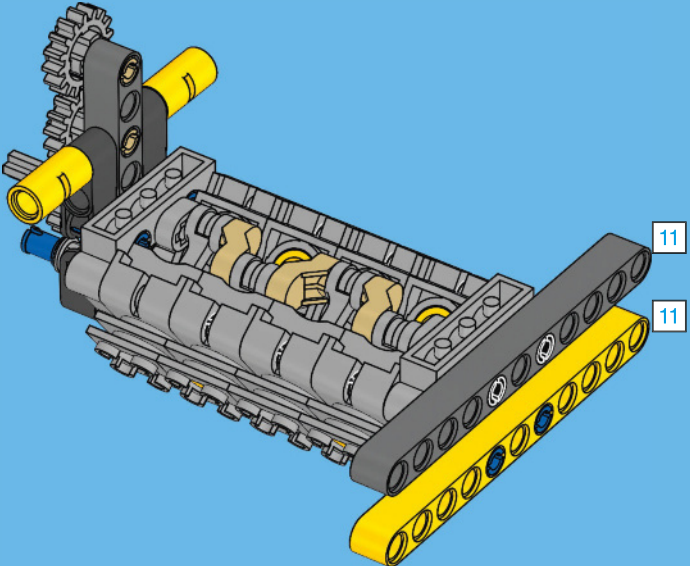

# 17

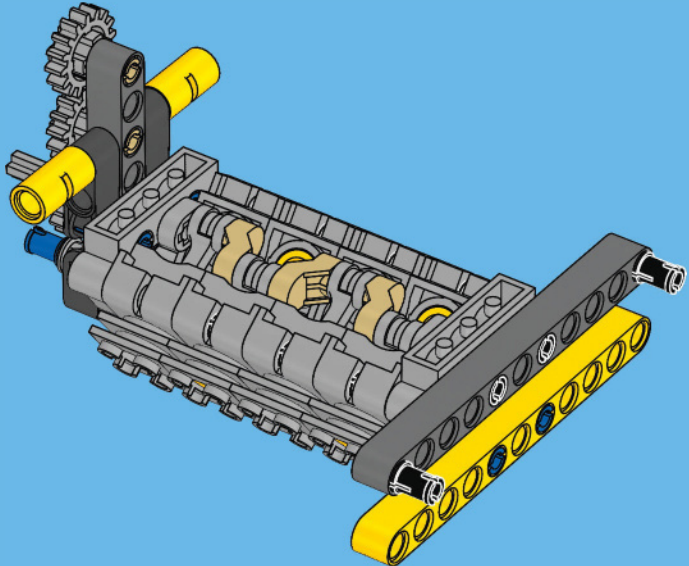

# 123

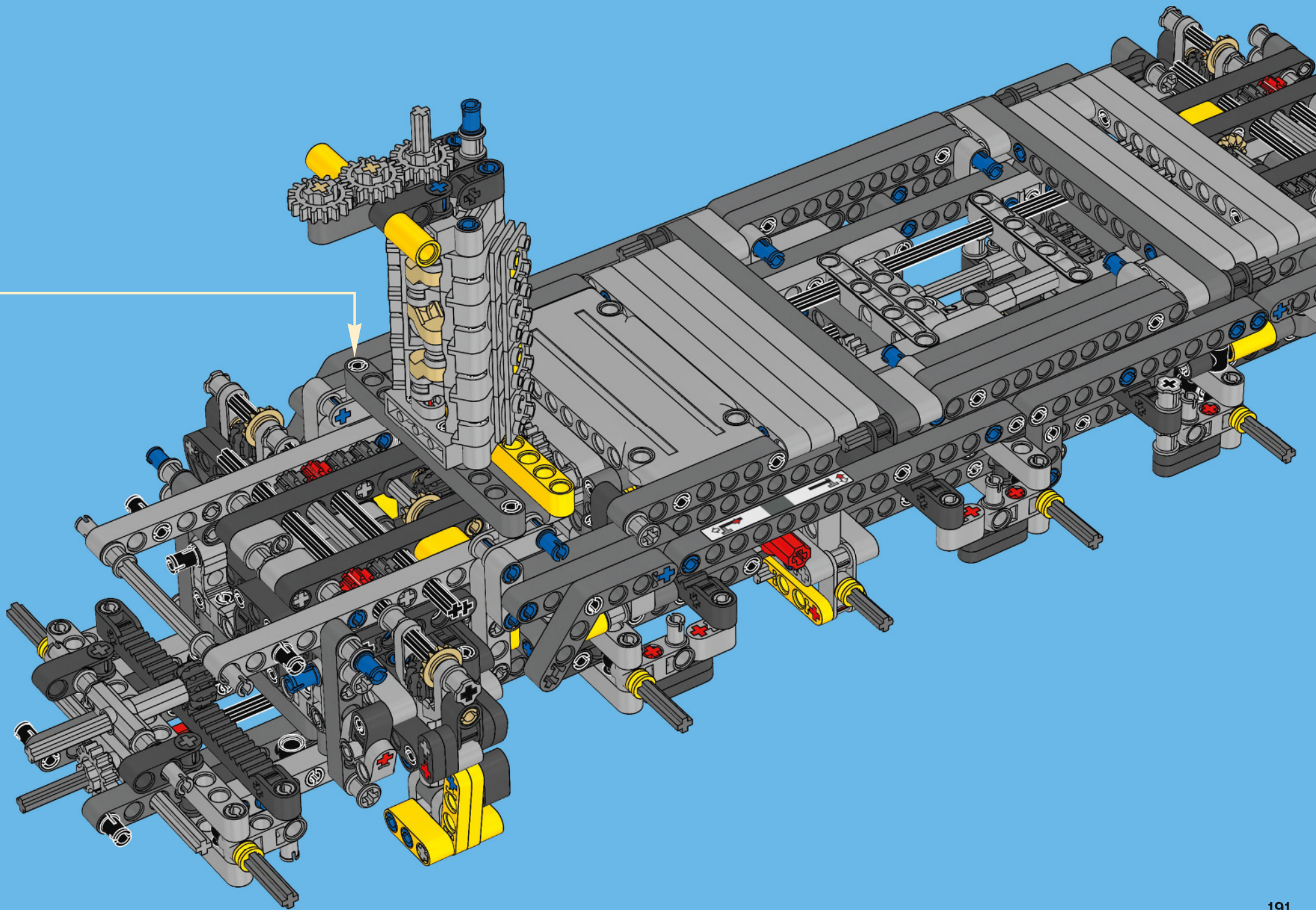



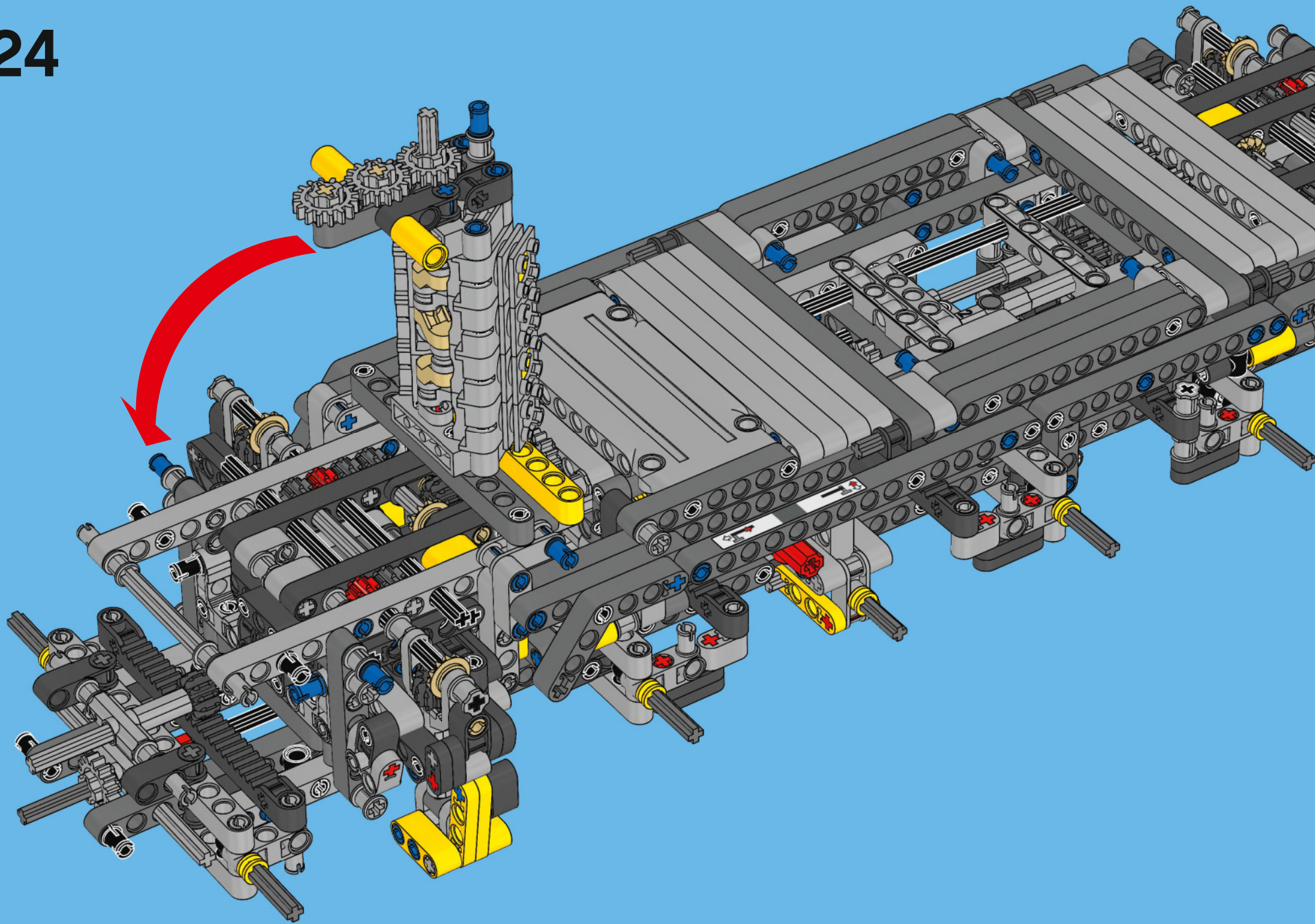





1x

# 125

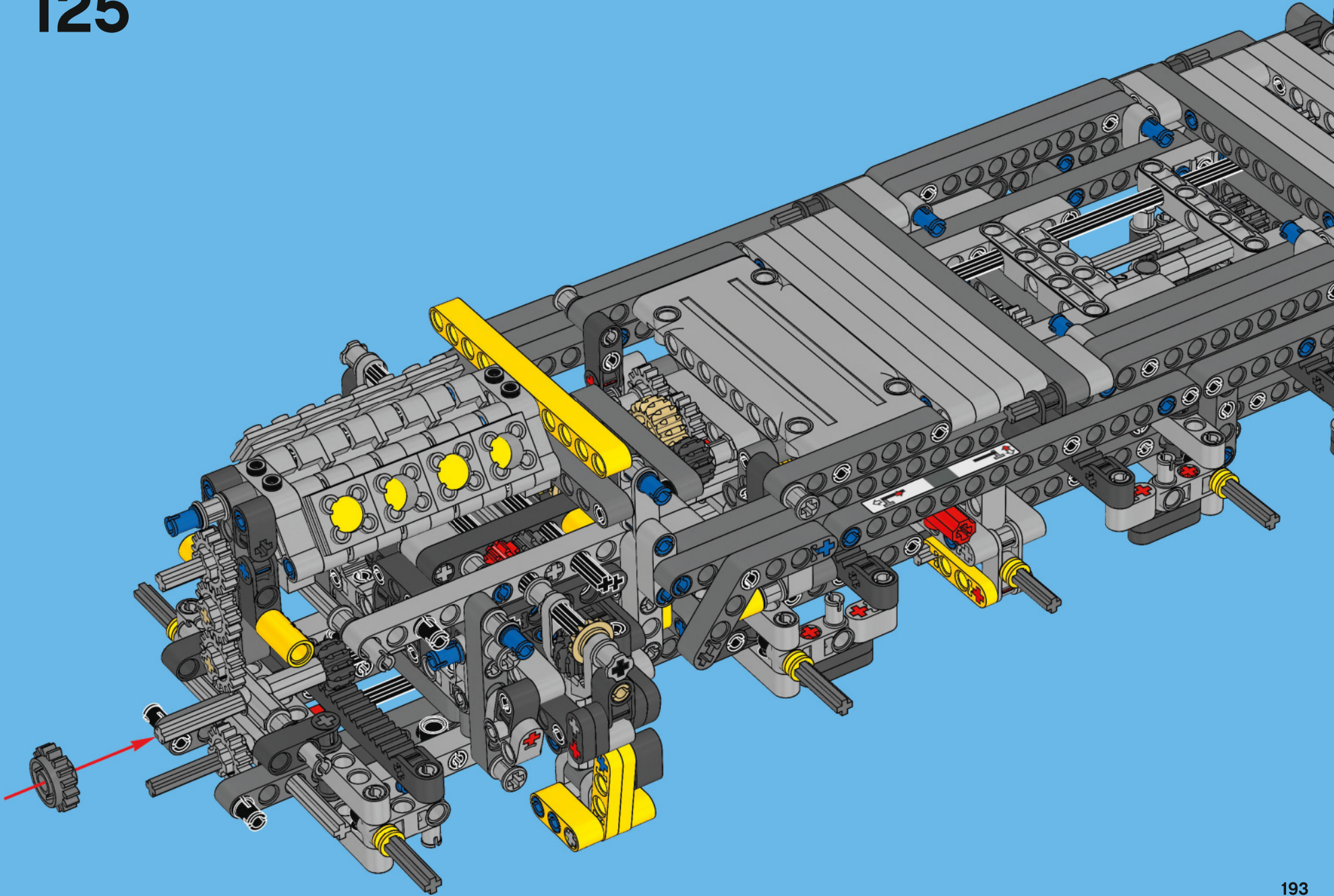



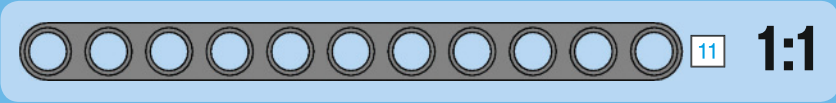
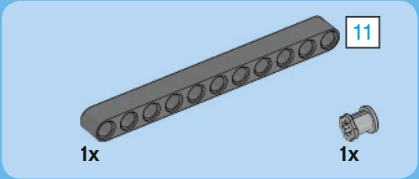

# 126

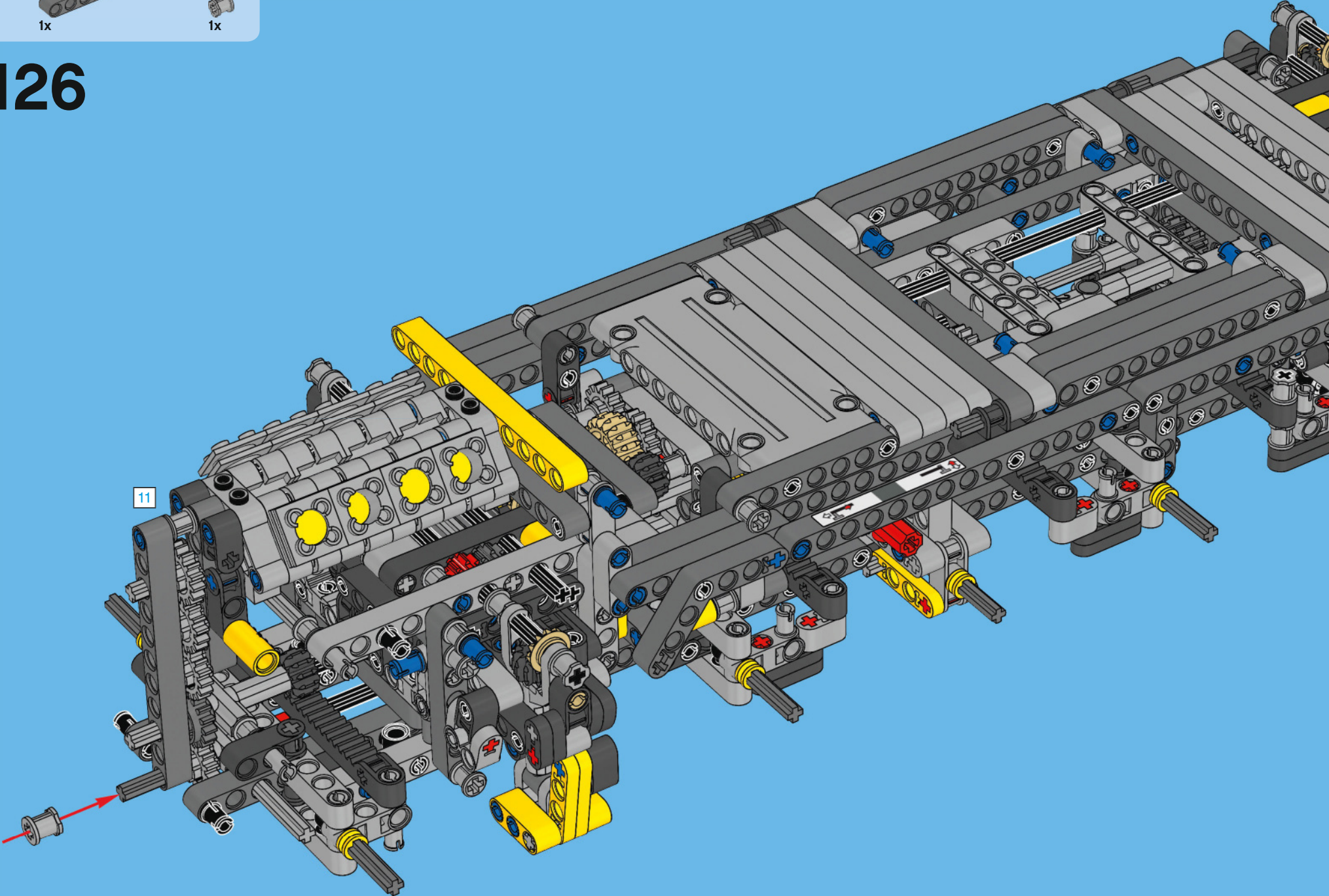

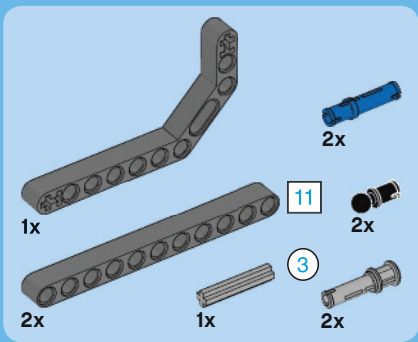

# 127

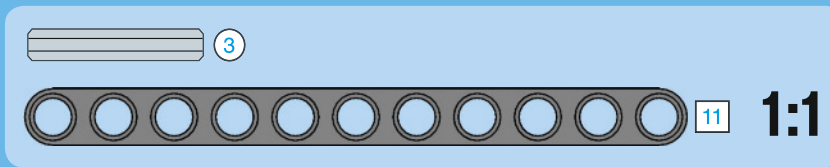

1

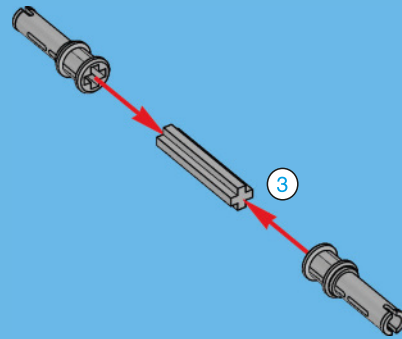

2

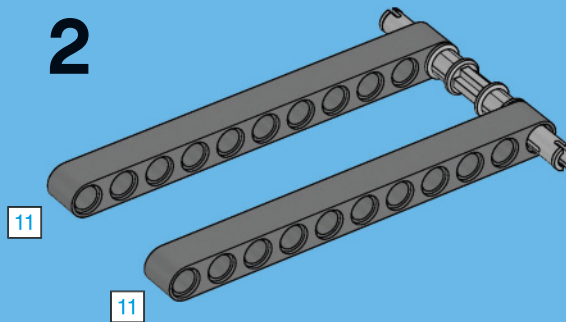

3

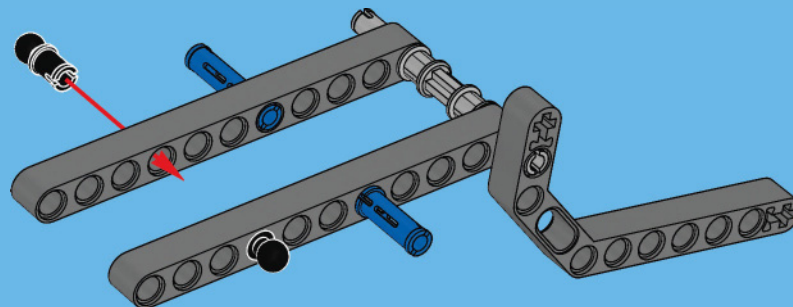



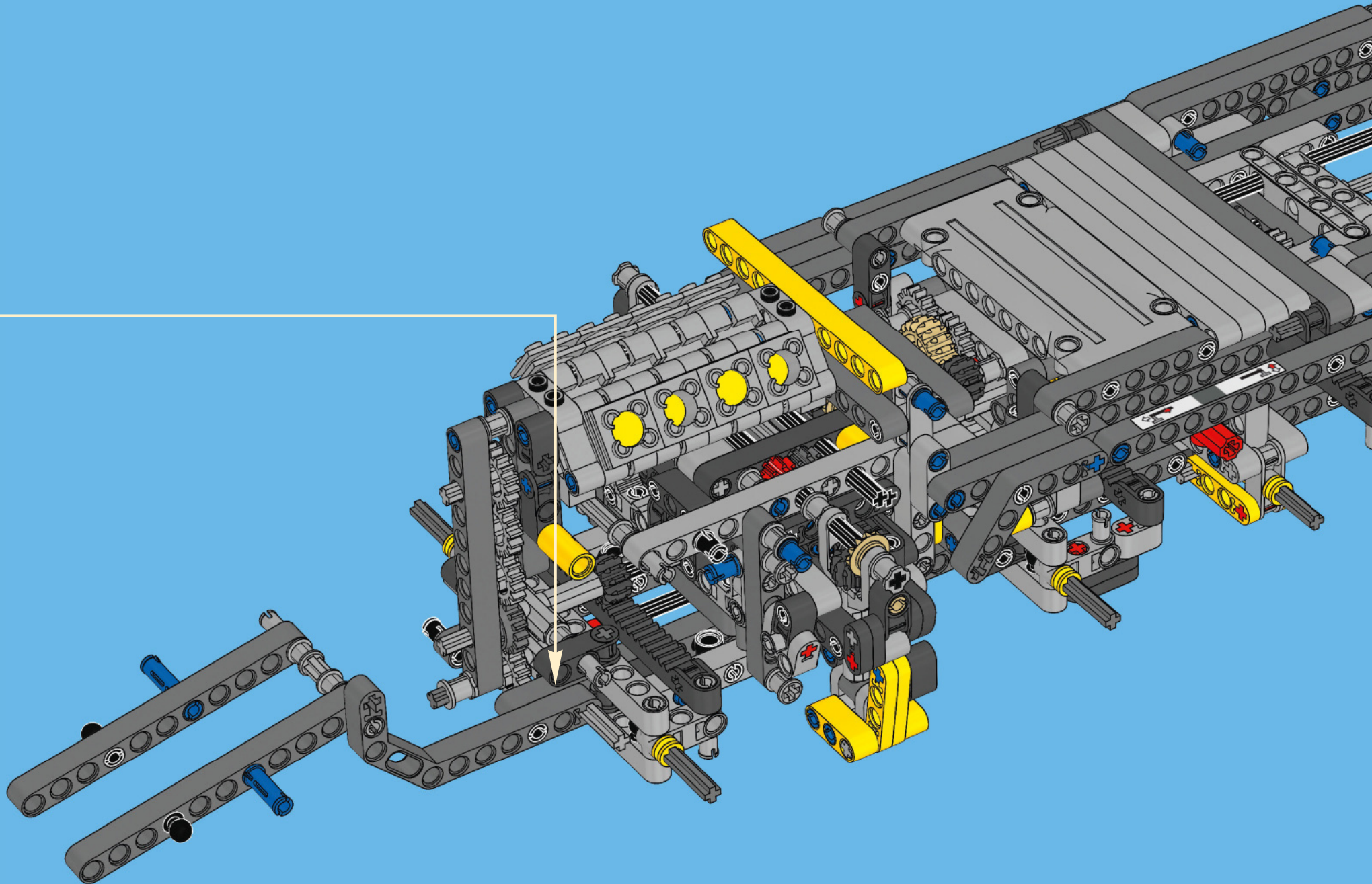

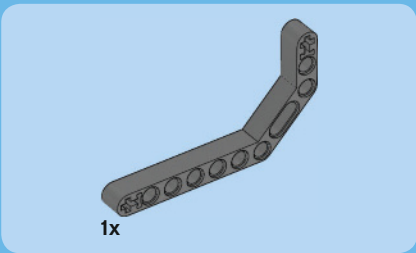

128

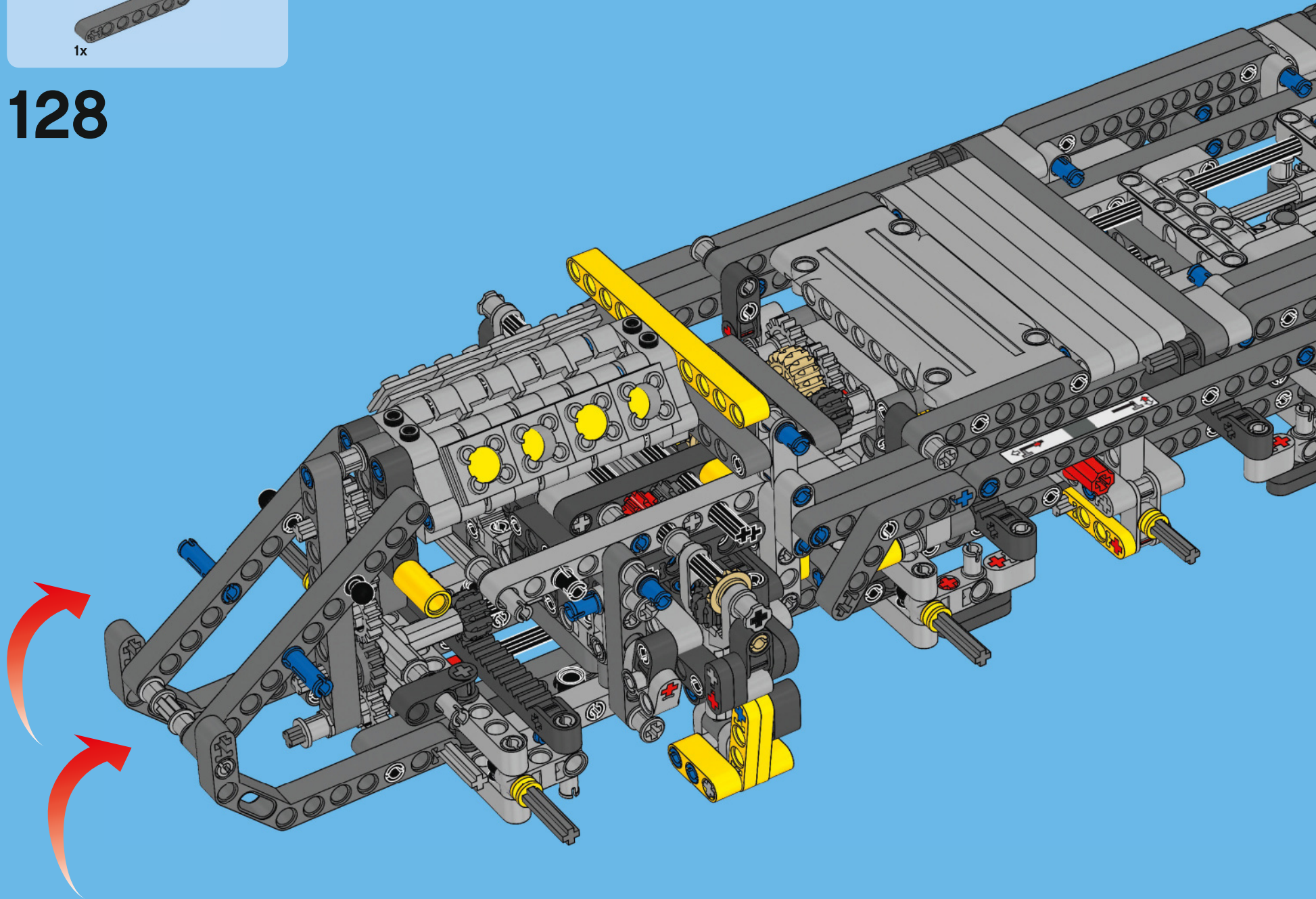



# 129

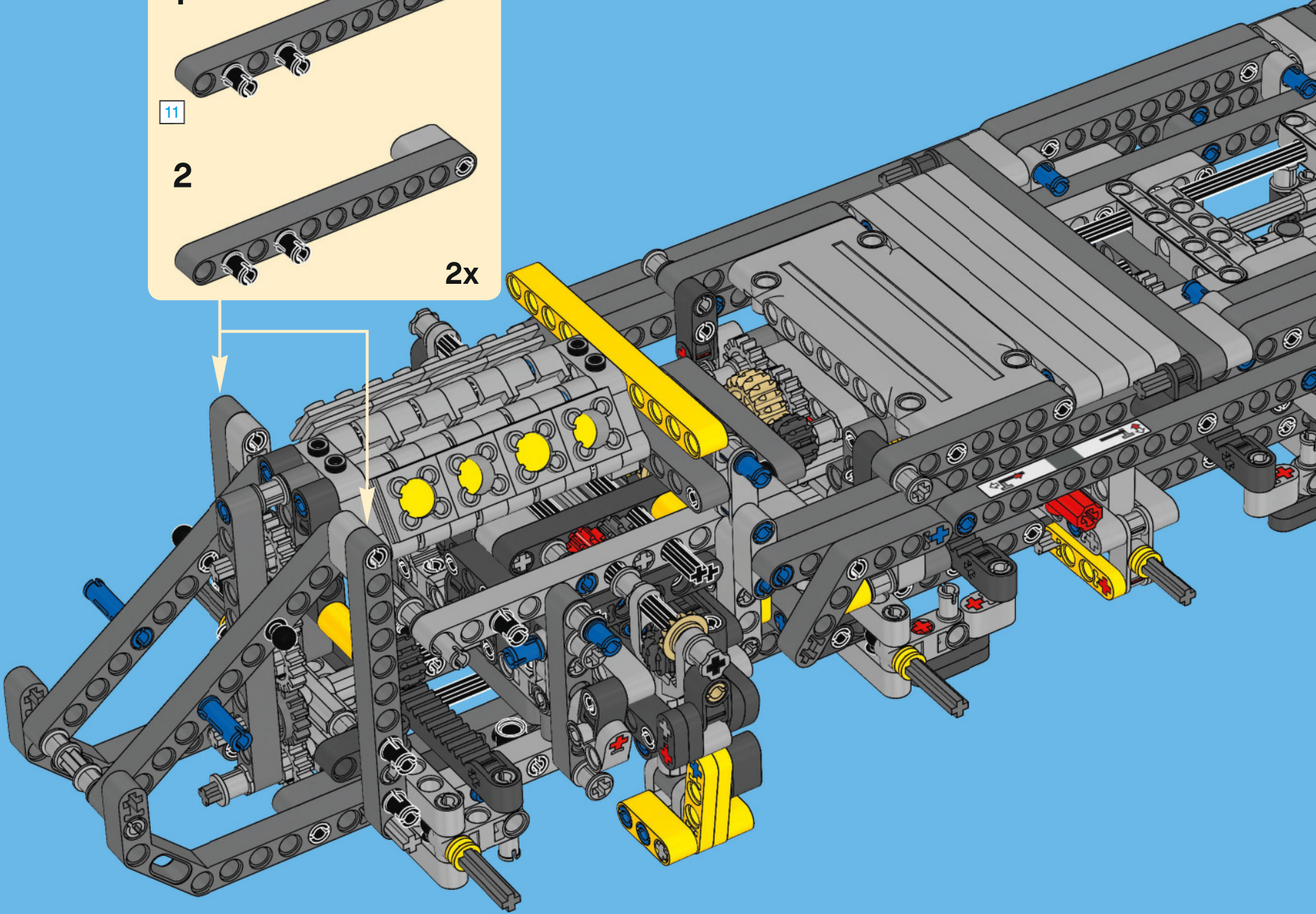
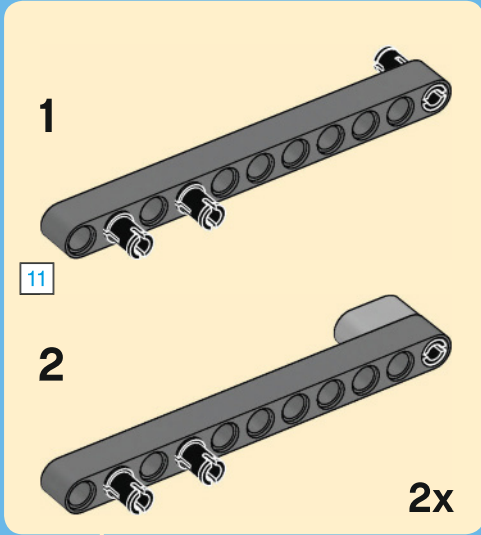
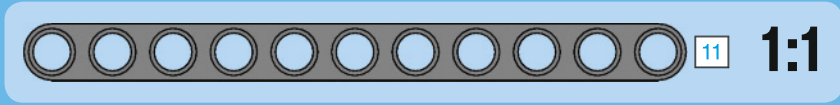
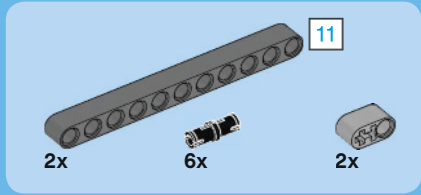



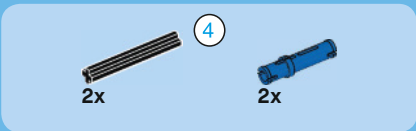

130

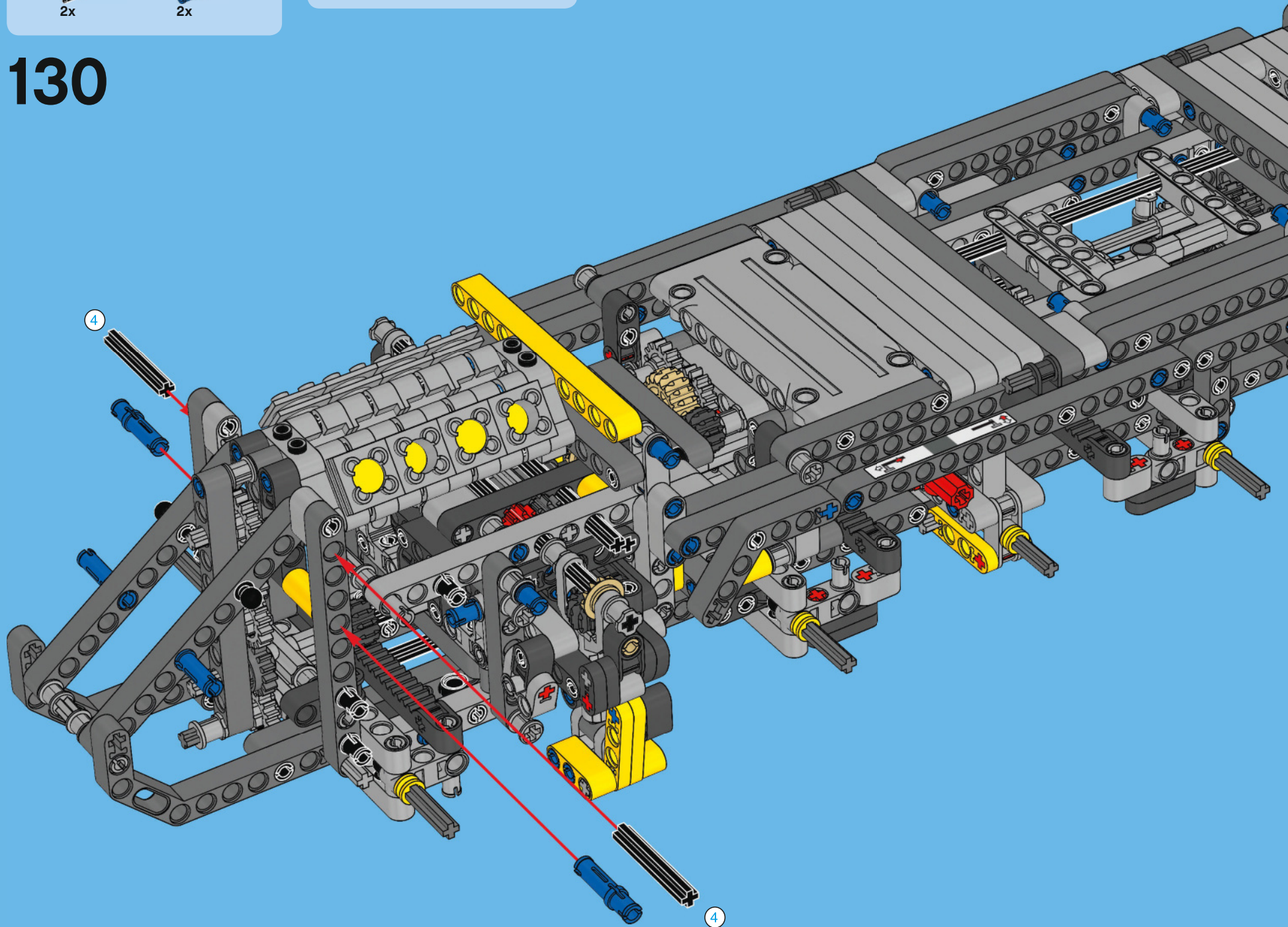



 2x  
  2x  
  2x  
 3

 3  
 1:1

# 131

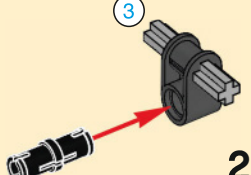
 3

2x

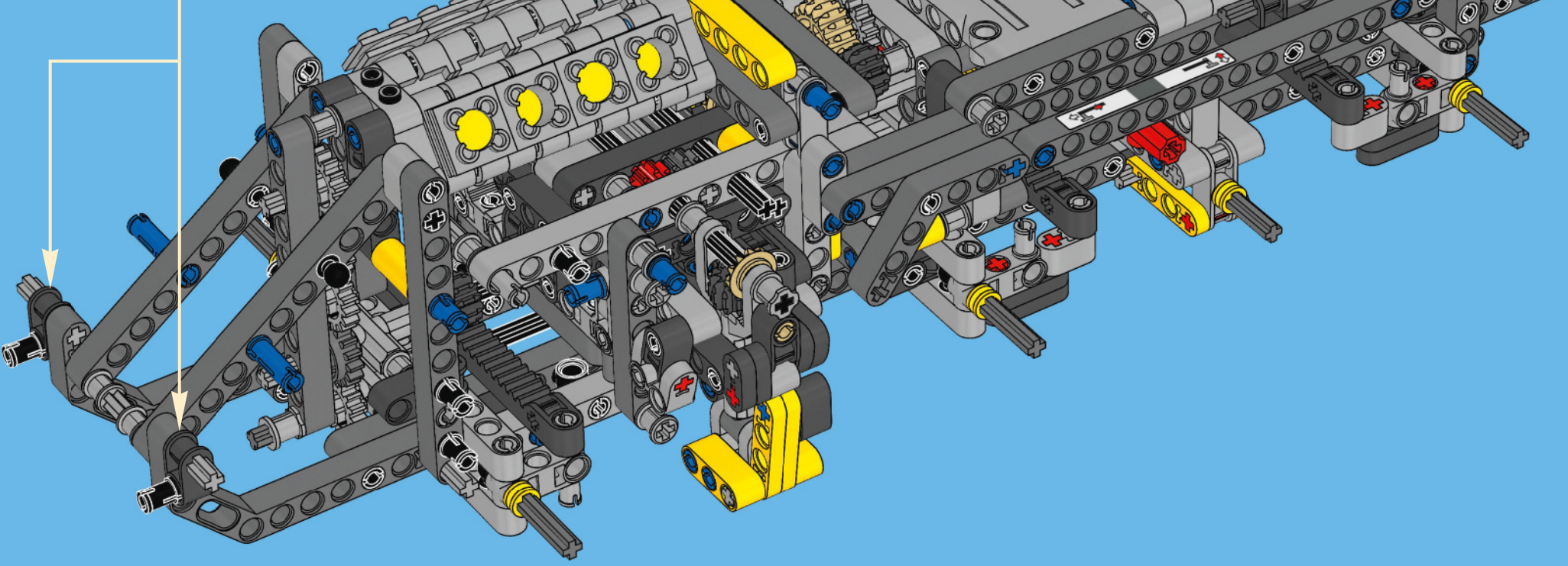

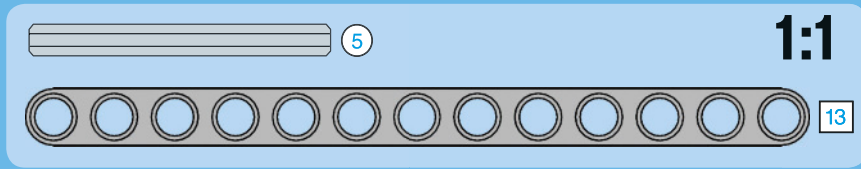
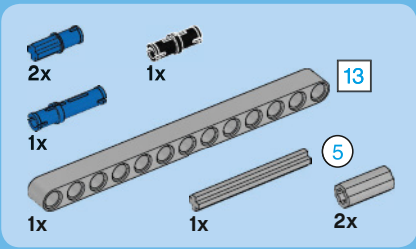

# 132

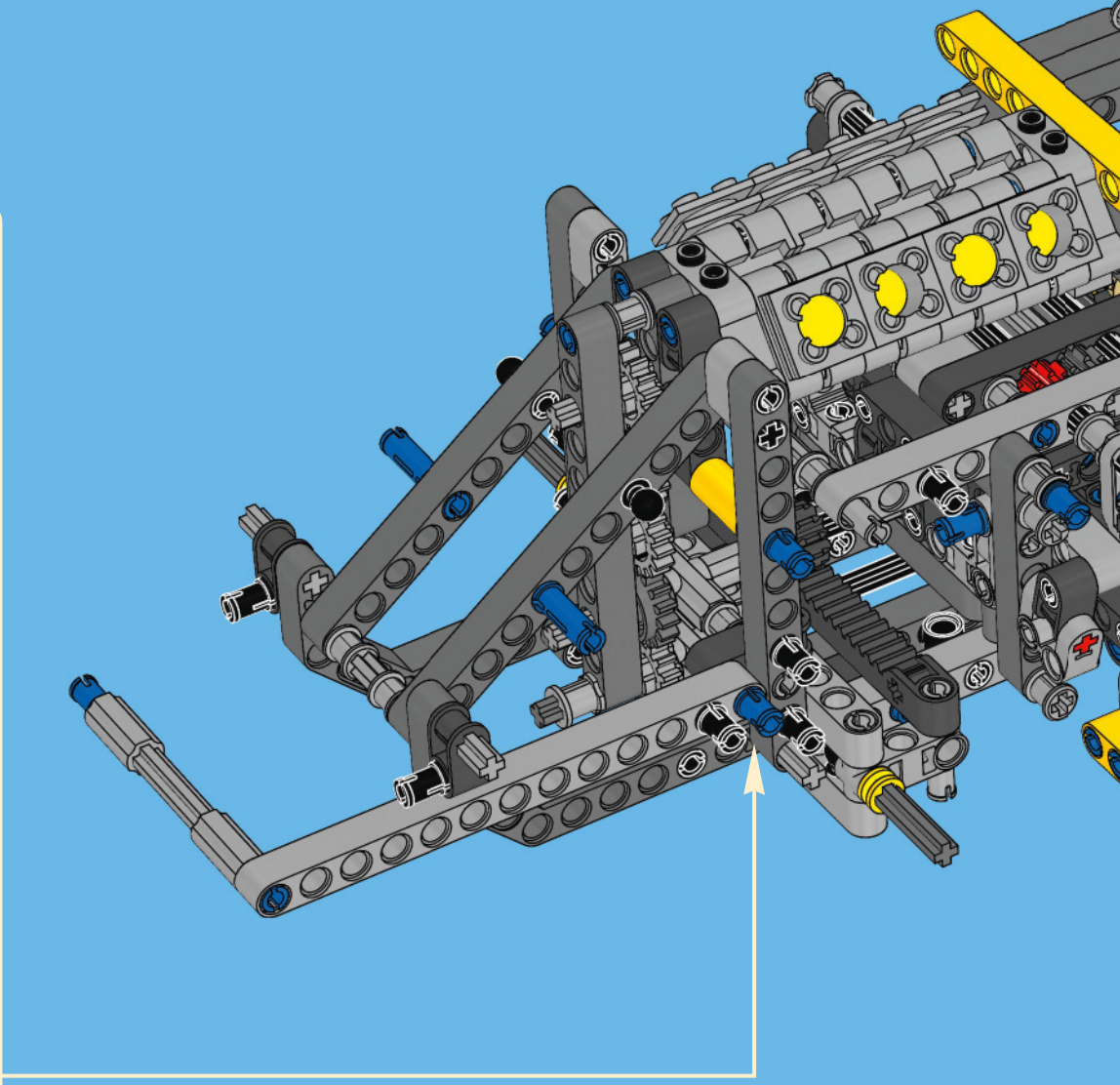
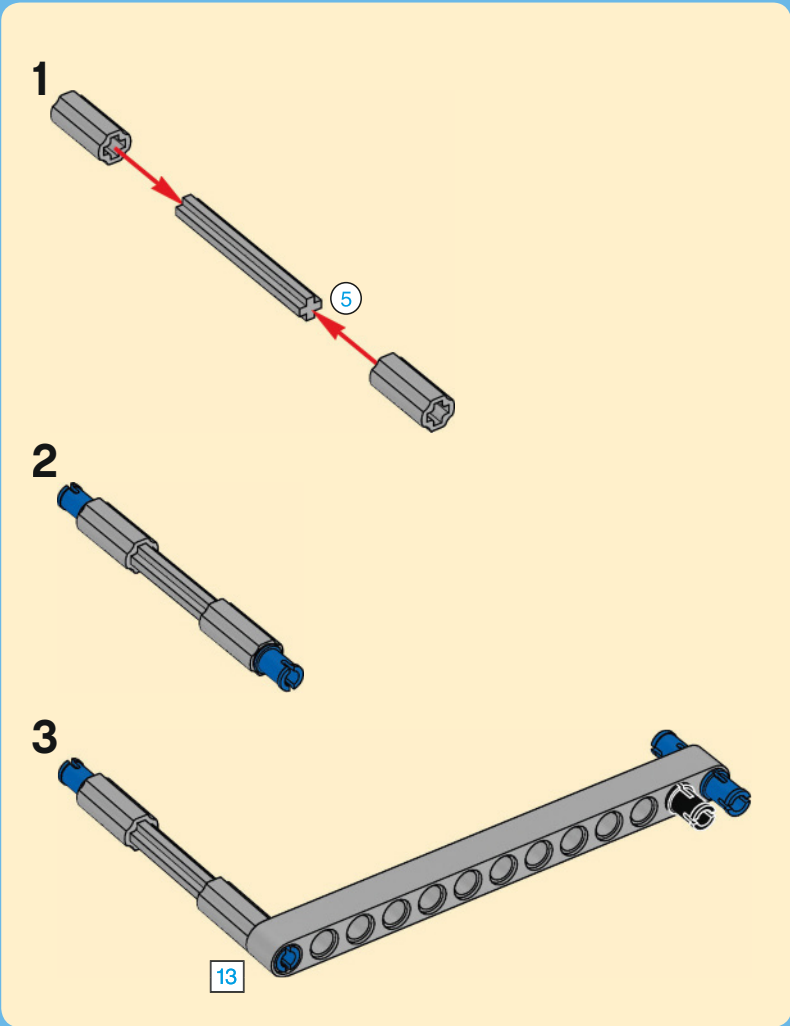



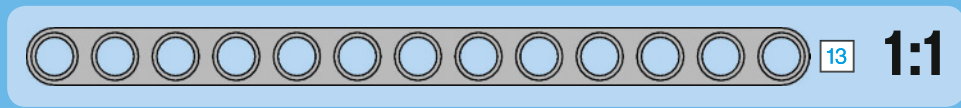
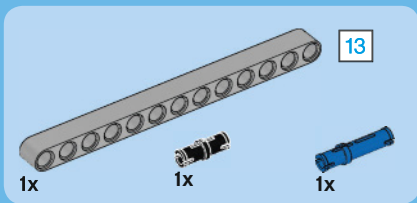

# 133

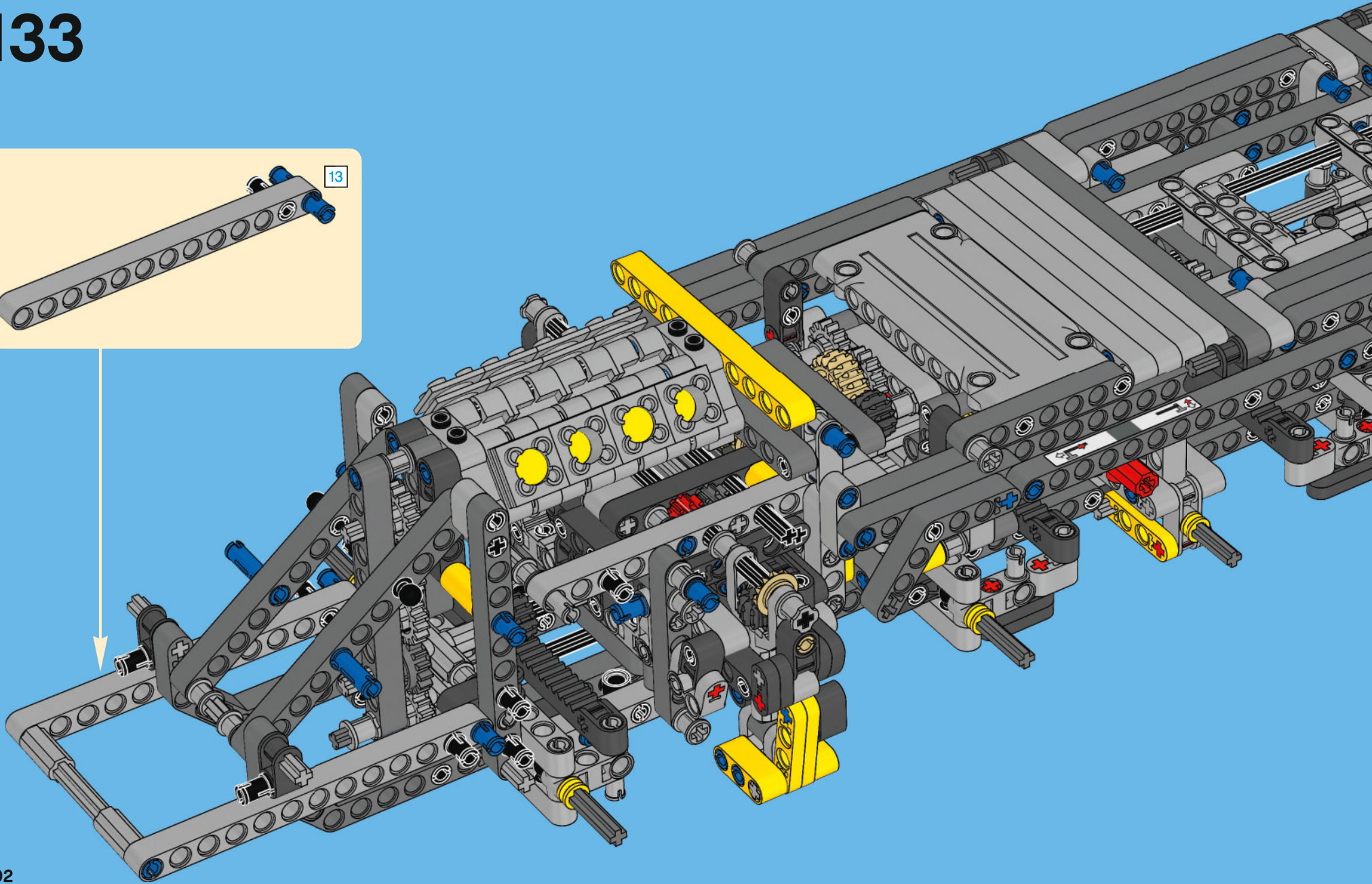
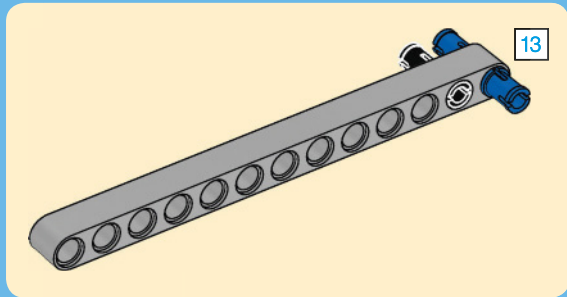





2x

# 134

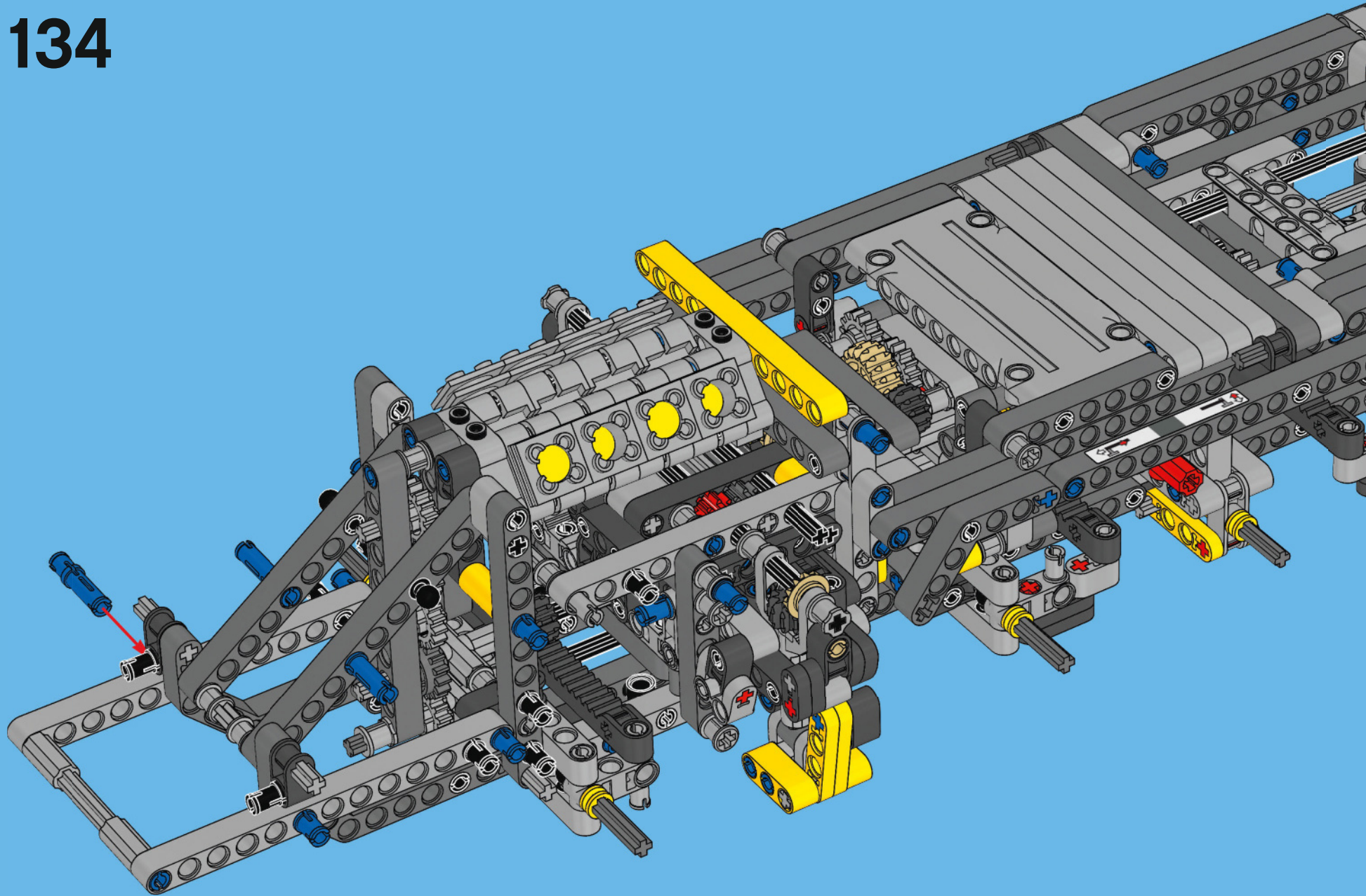



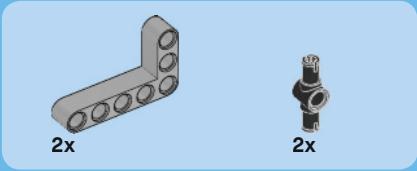

# 135

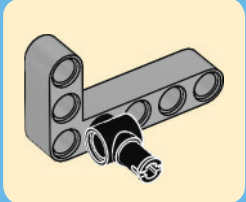
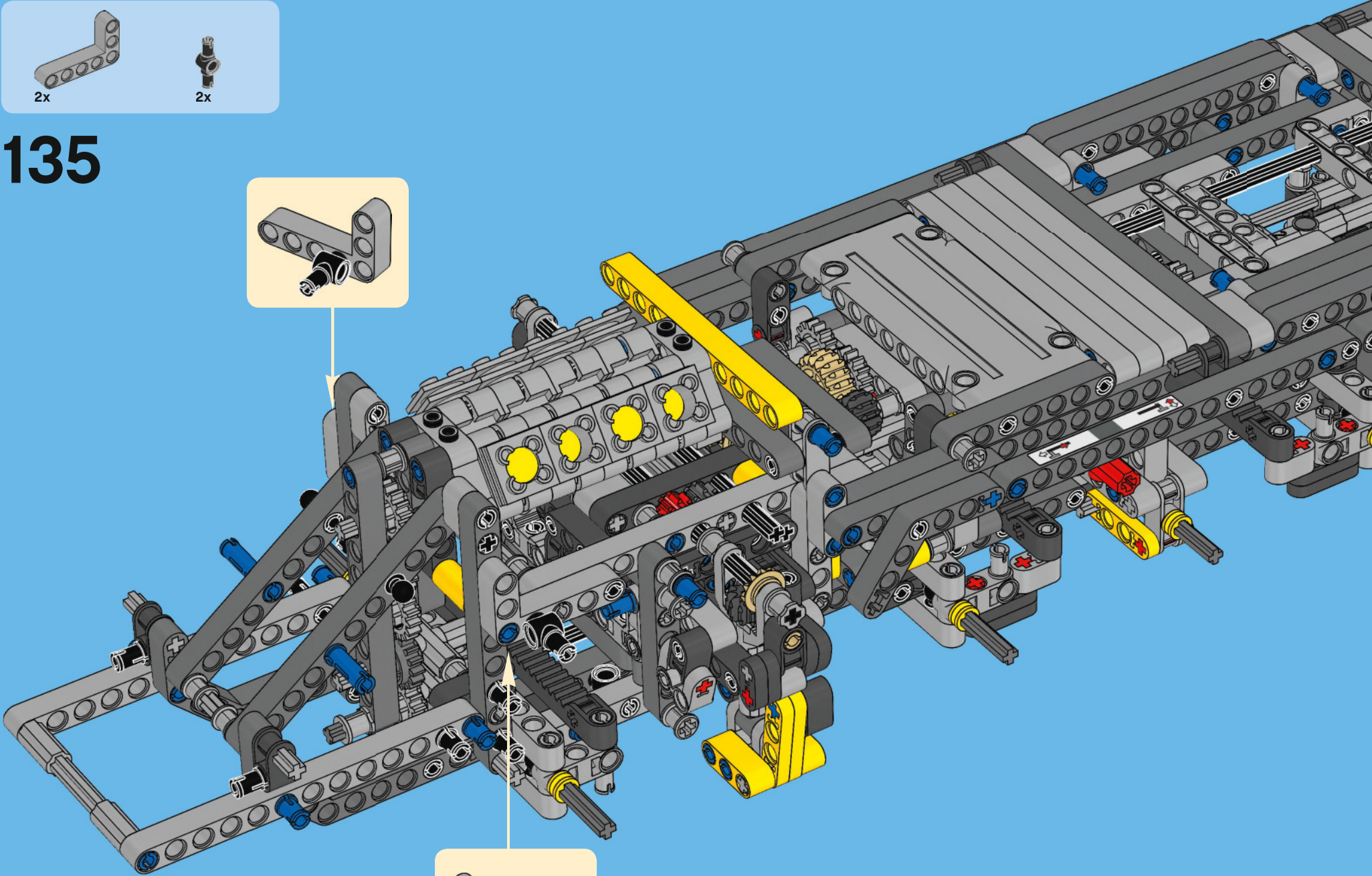
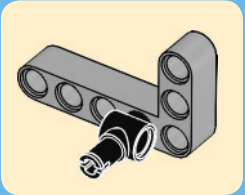



2x



2x

# 136

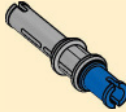

2x

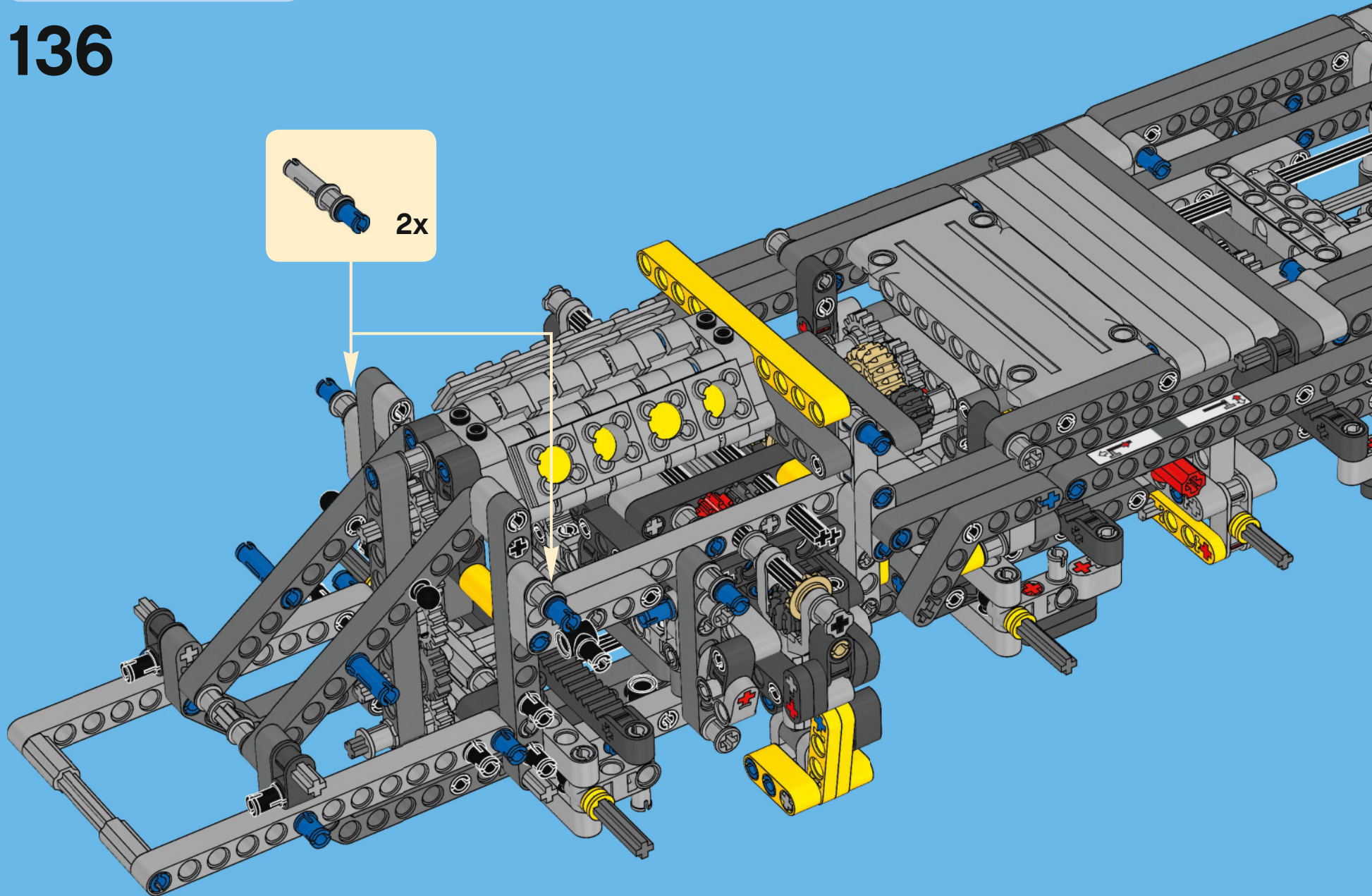



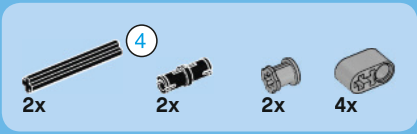

137

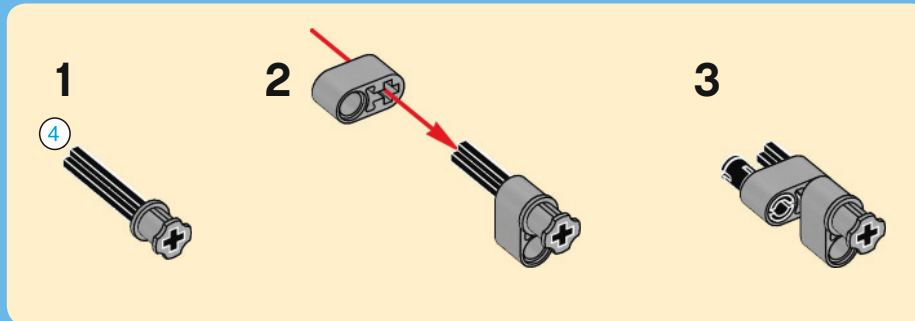
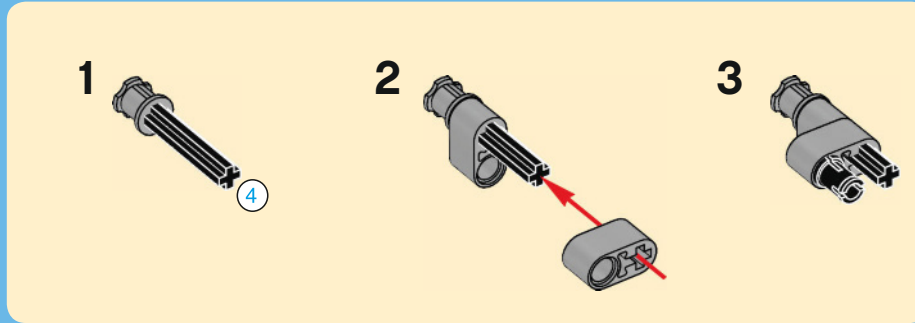

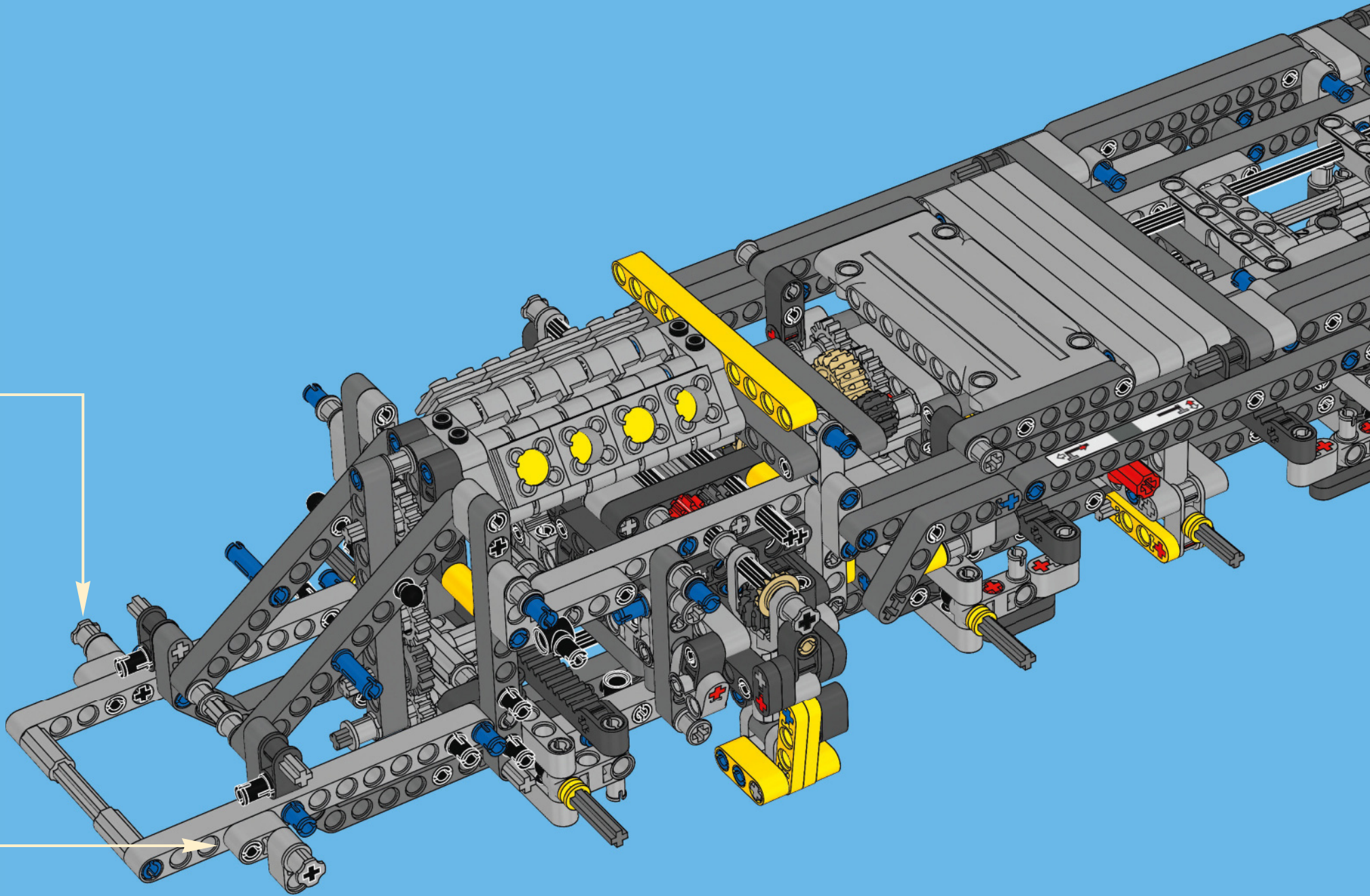



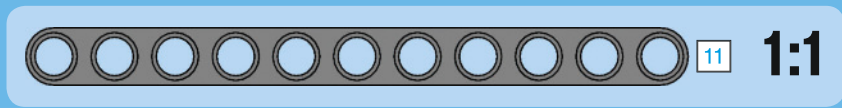
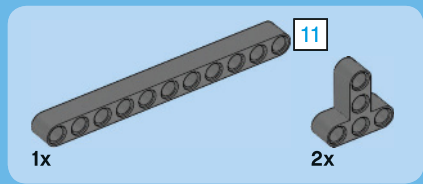

# 138

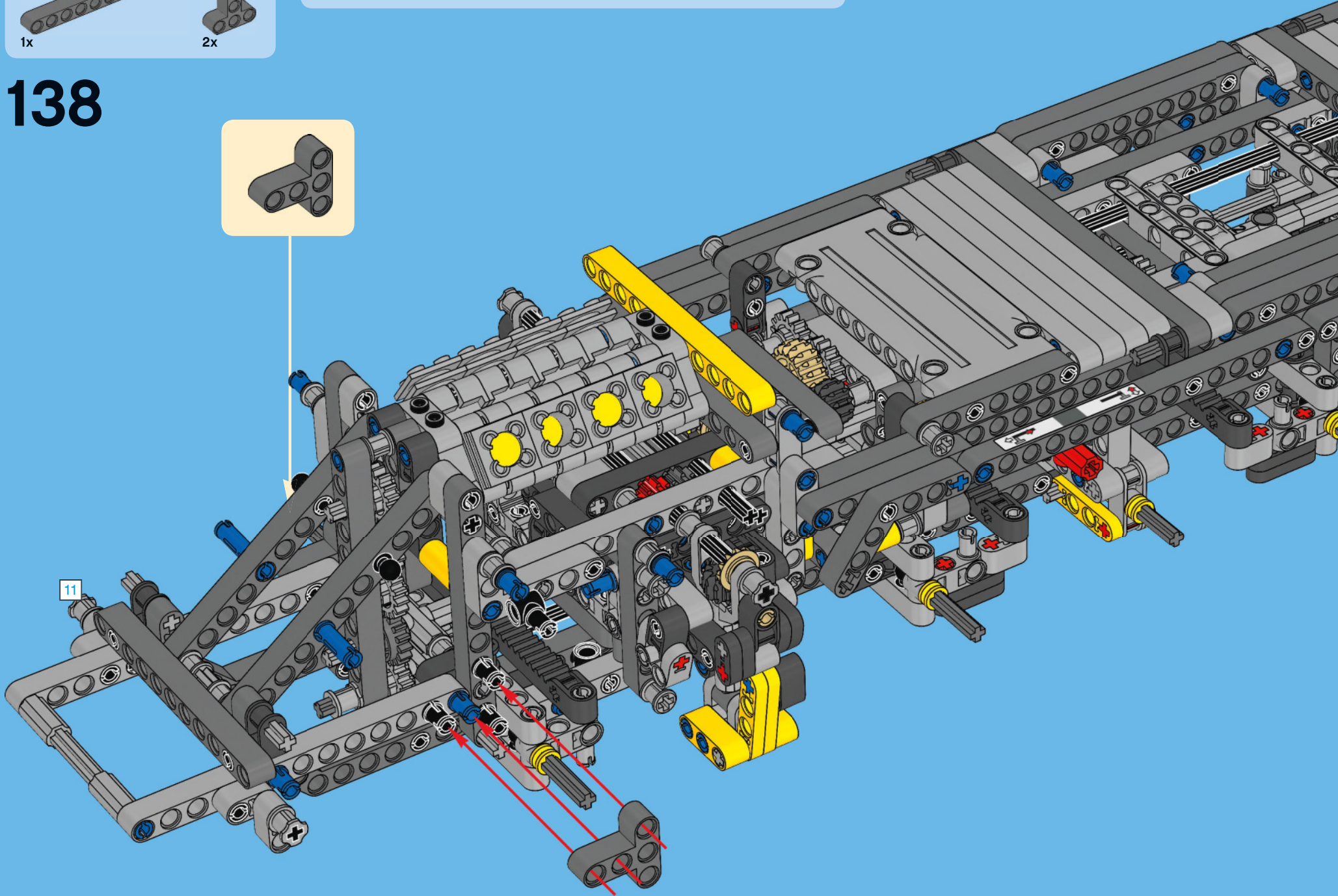

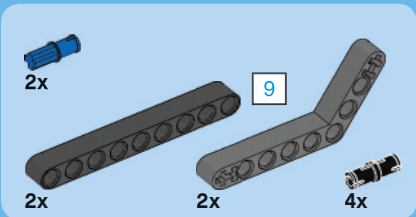

# 139

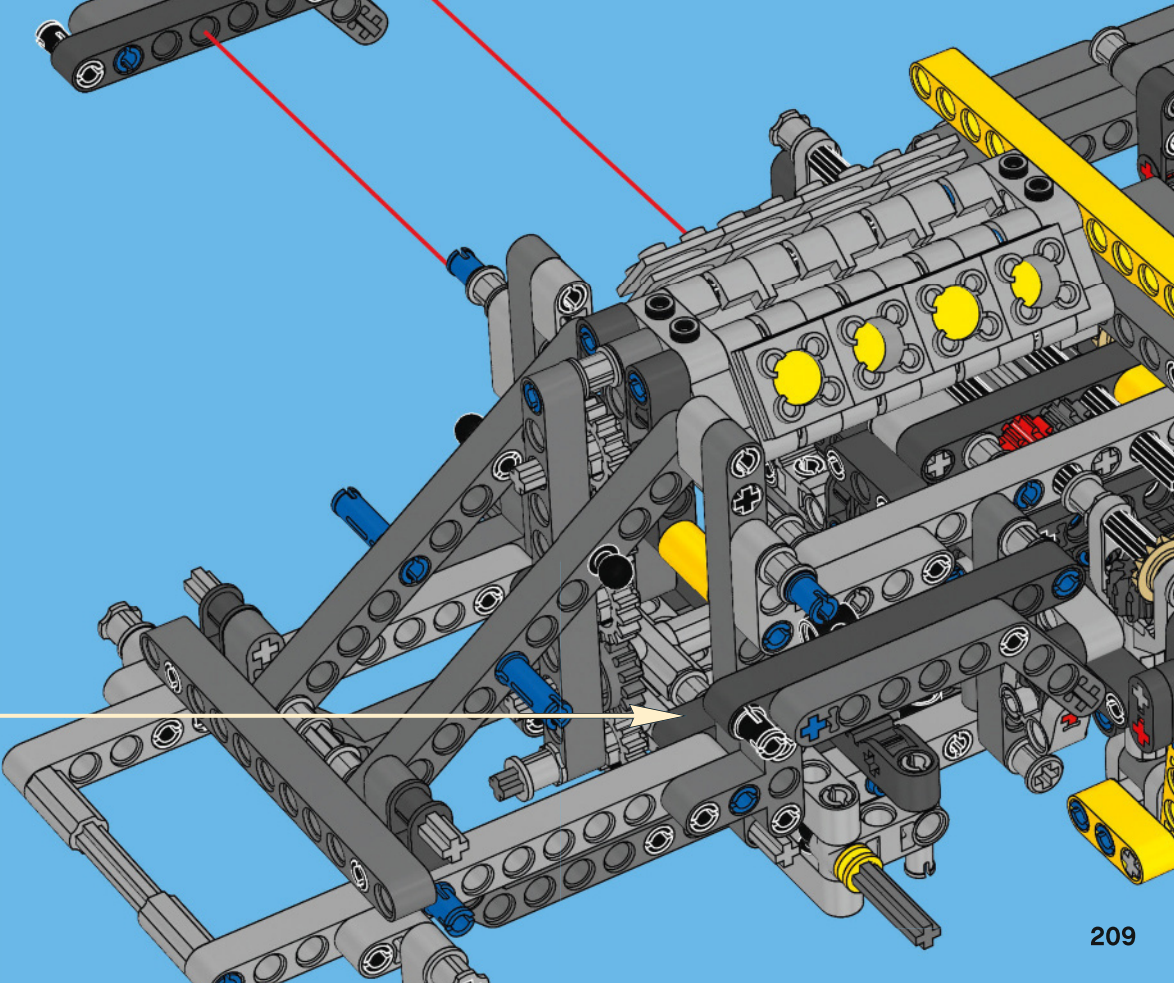
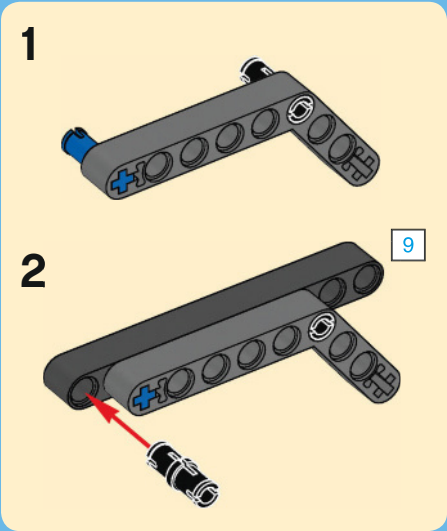
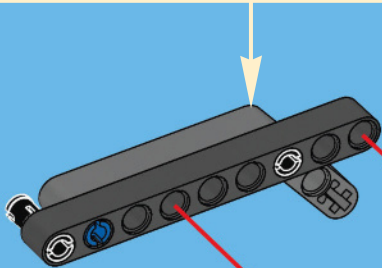
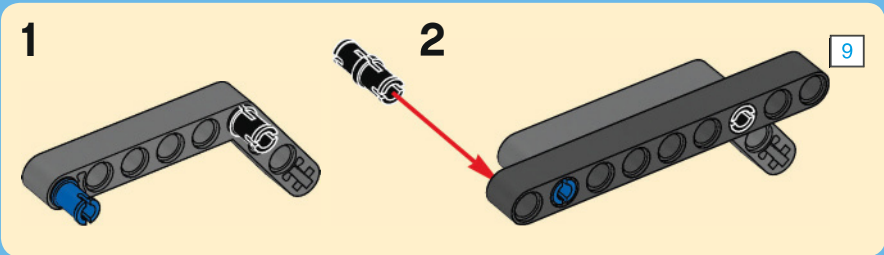
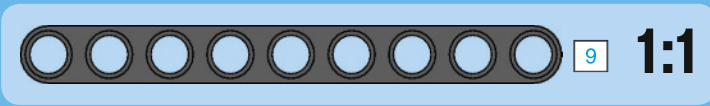



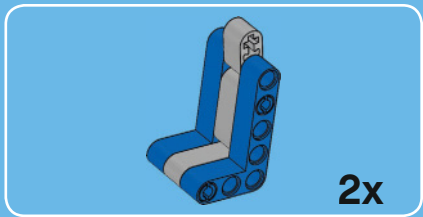

# 140

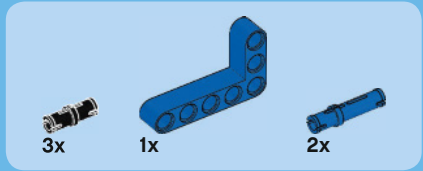

## 1

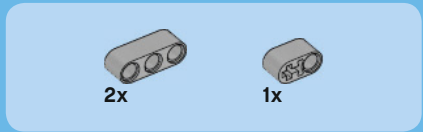
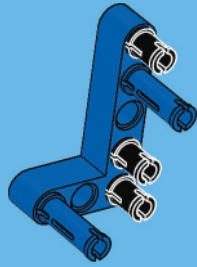

## 2

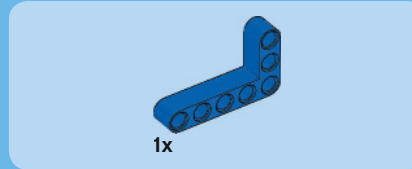
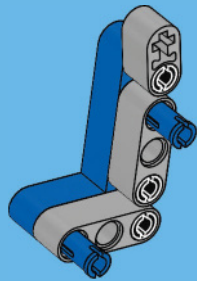

## 3

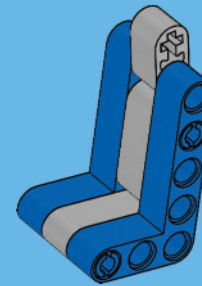

# 2x

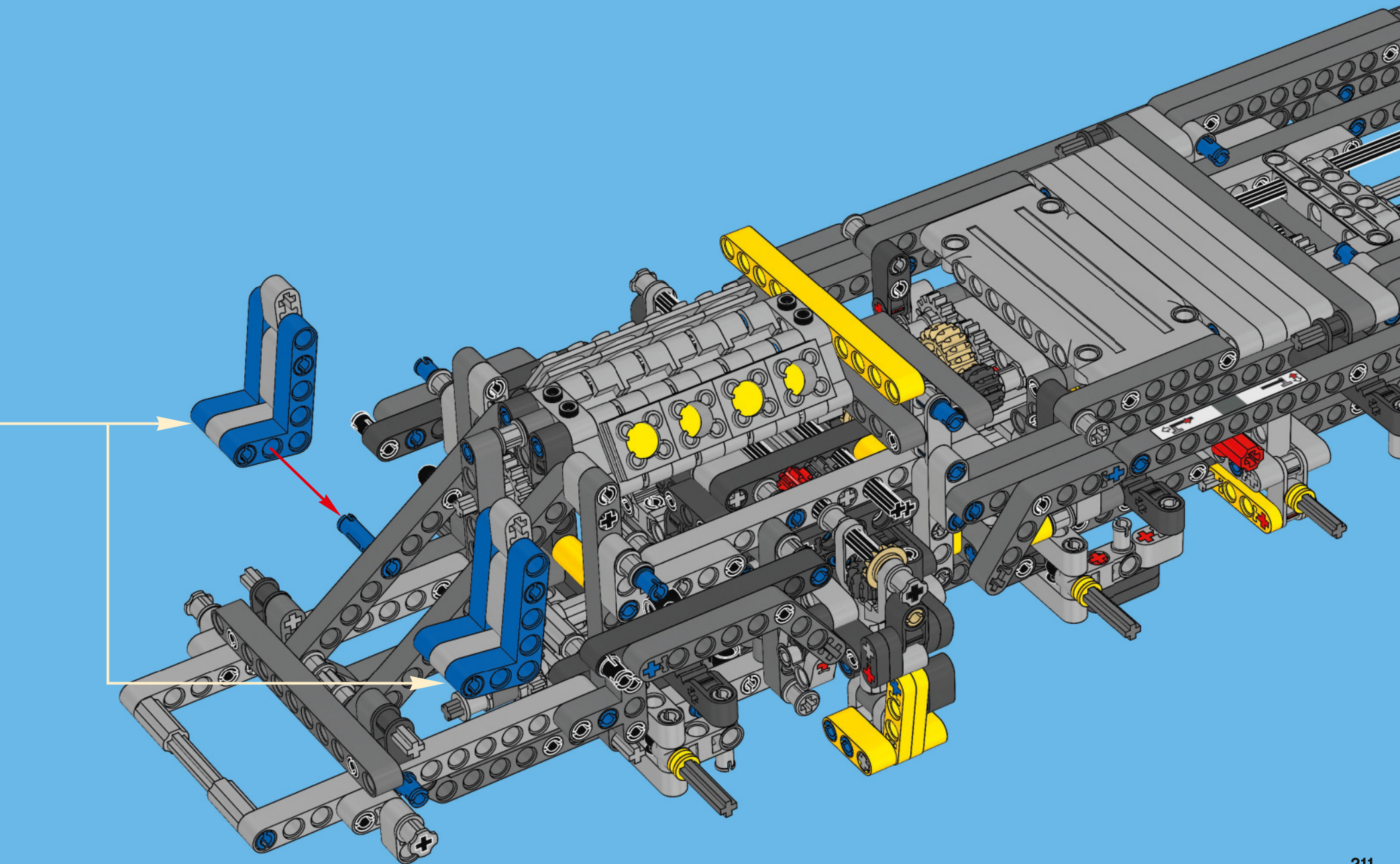



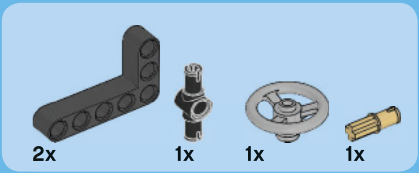

# 141

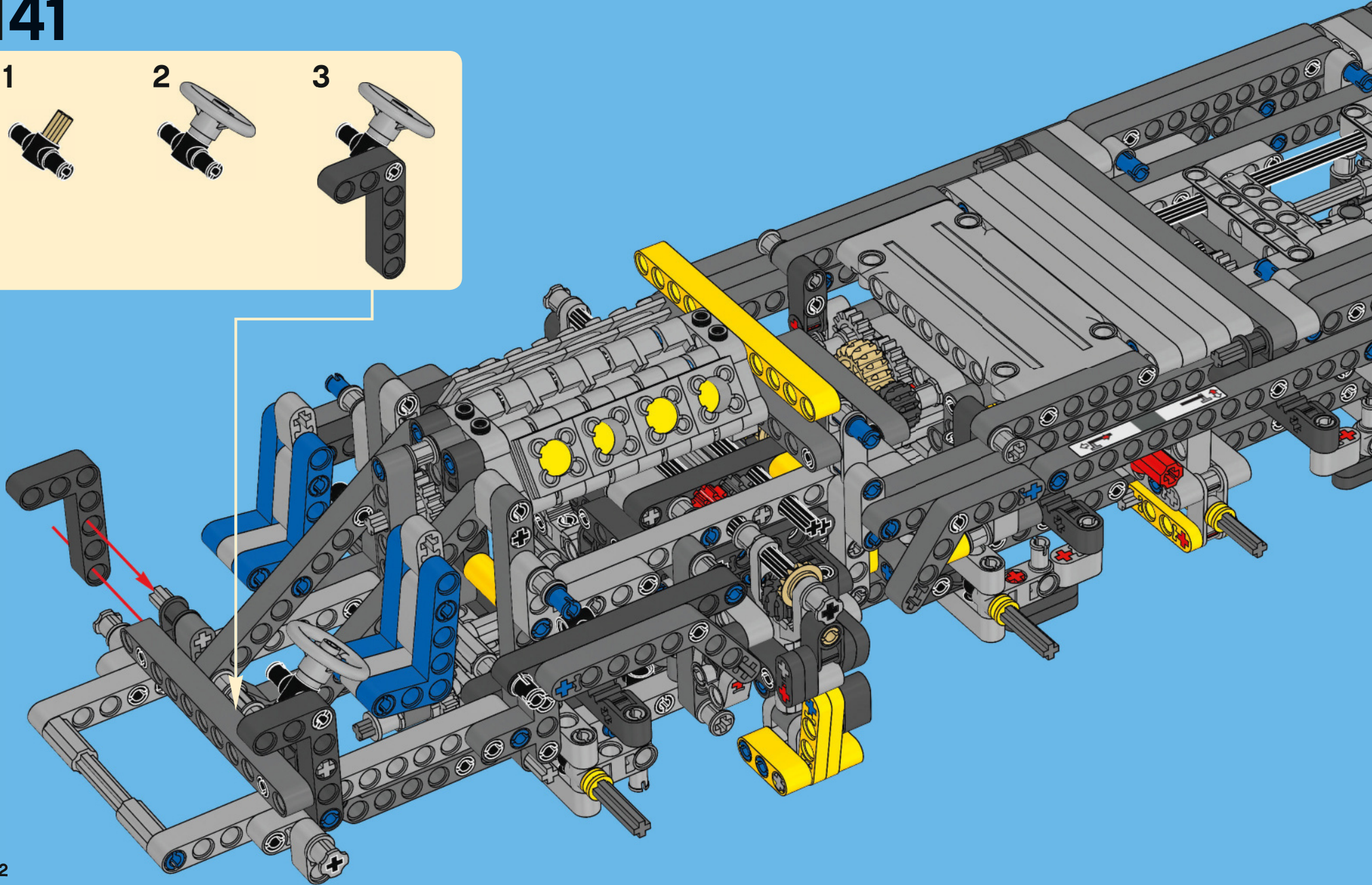
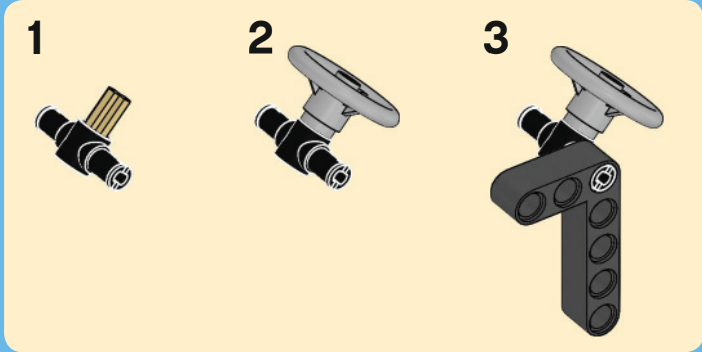



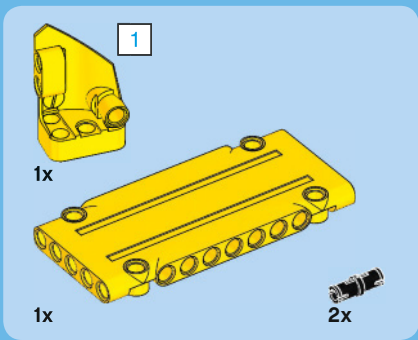

# 142

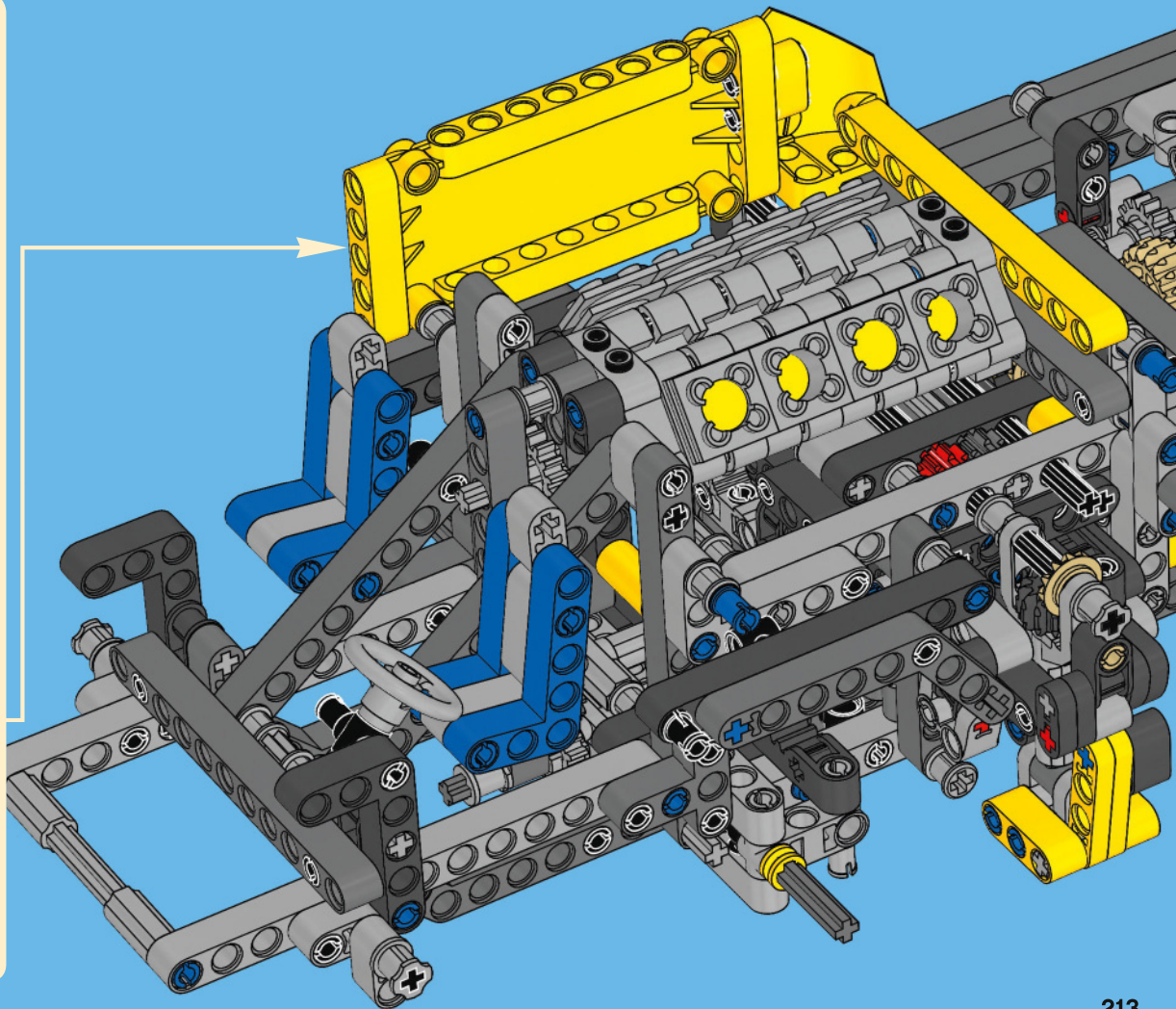
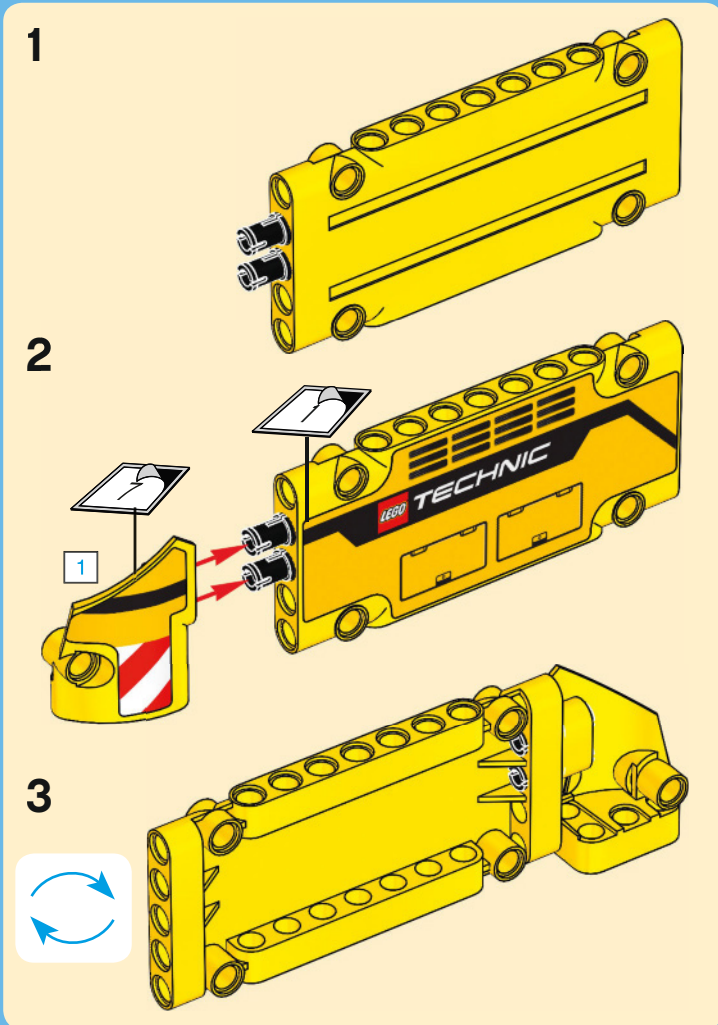



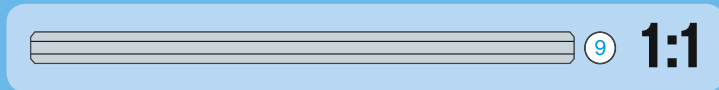
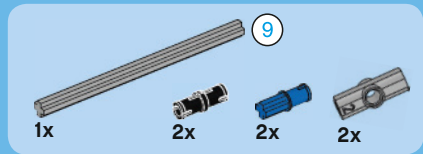

# 143

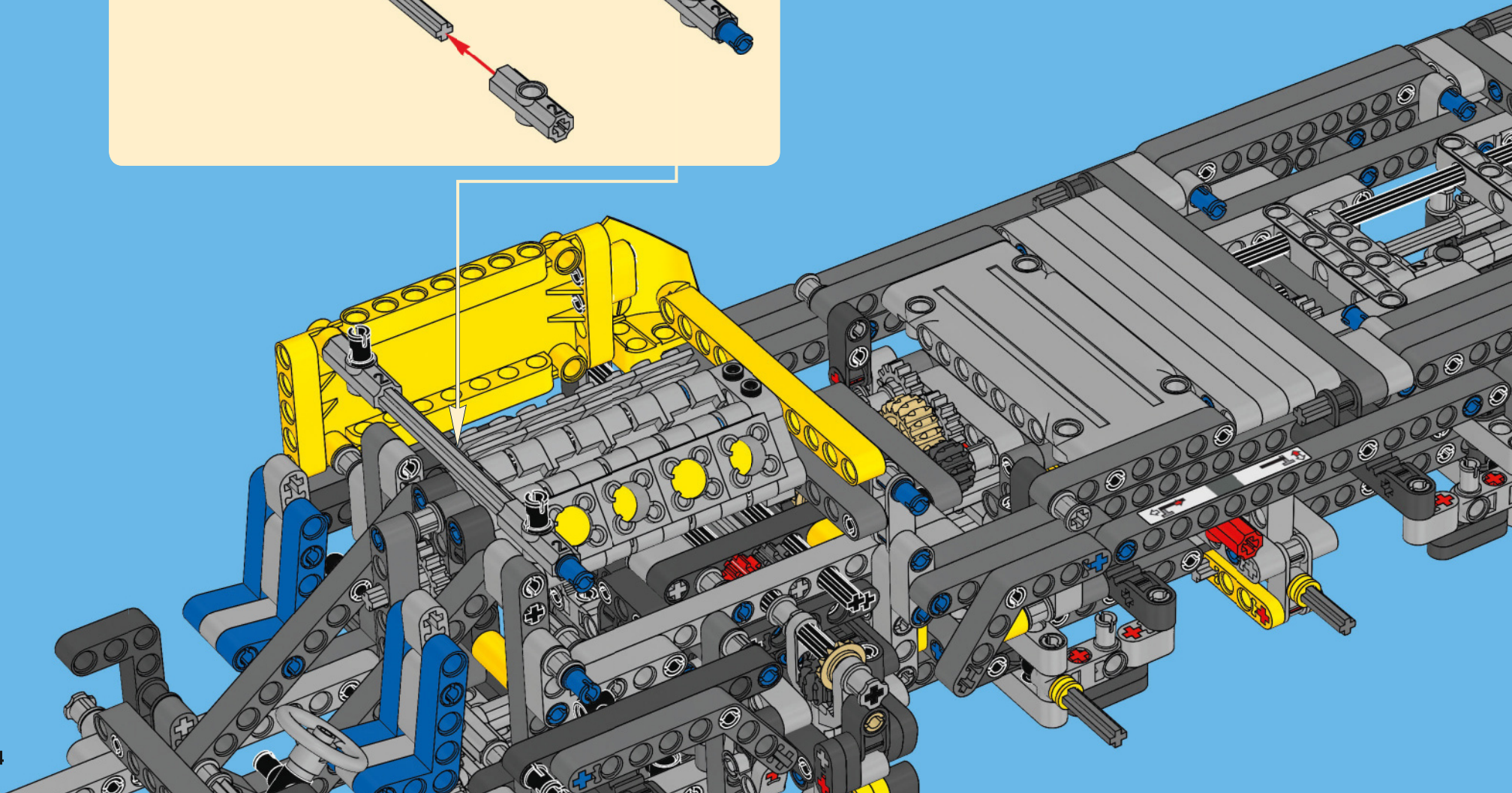
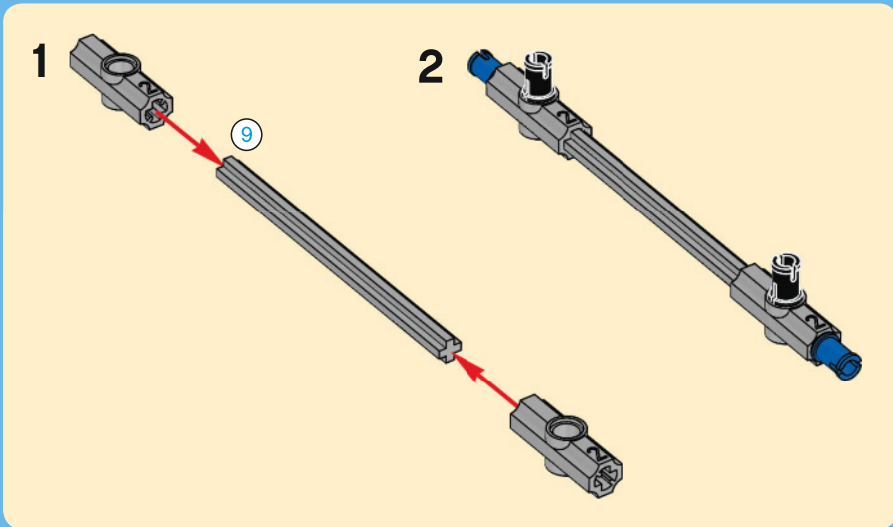



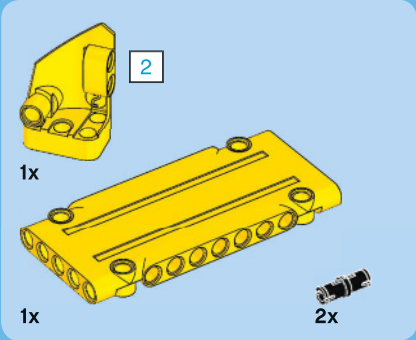

144

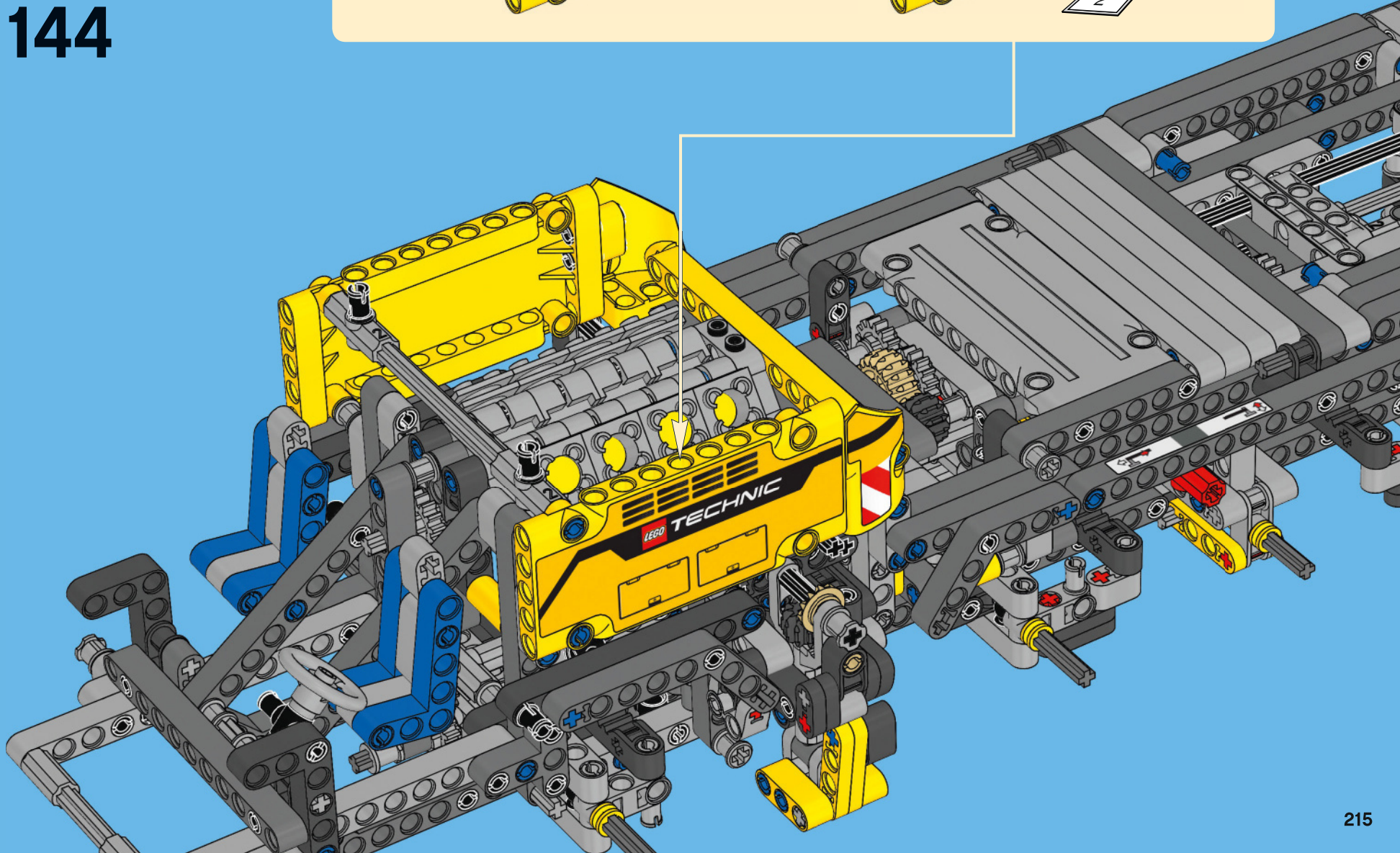
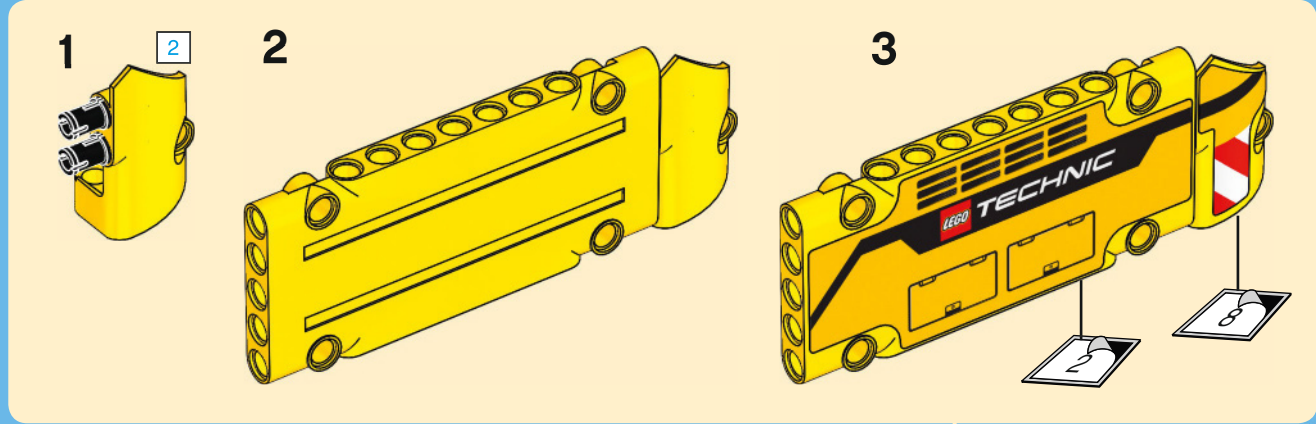



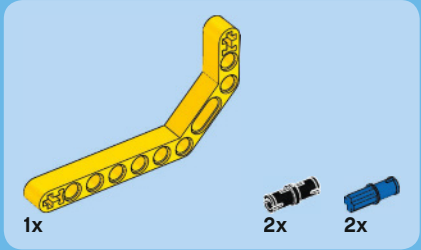
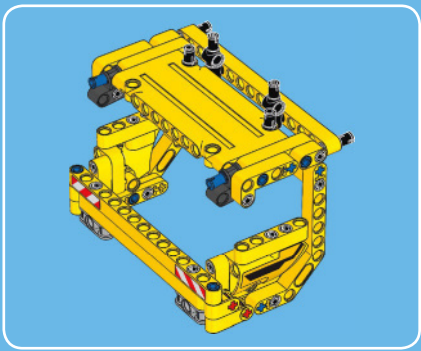

1

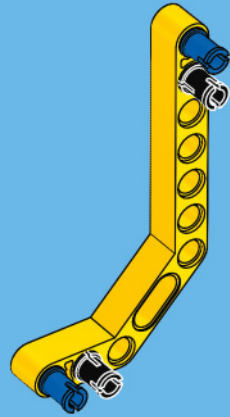

2

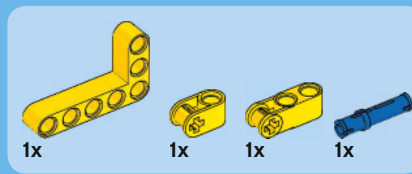
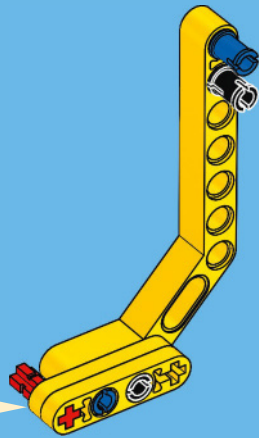
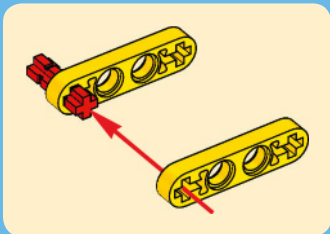

3

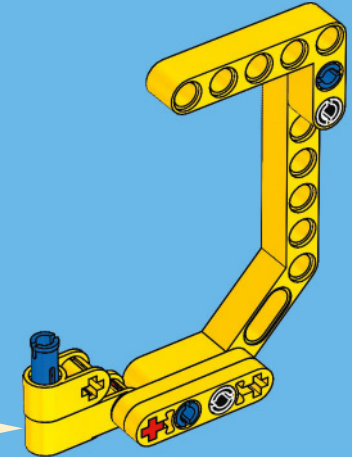
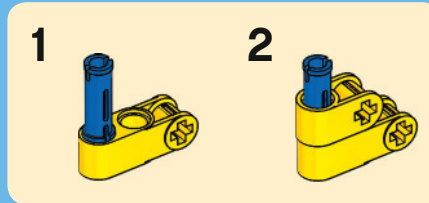

4

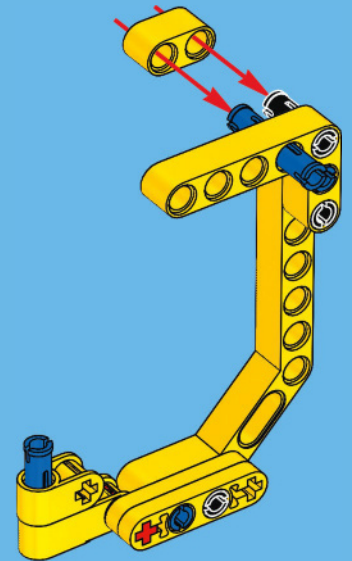

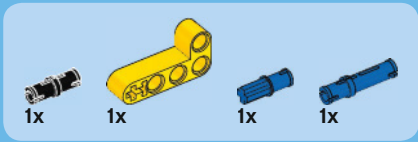

5

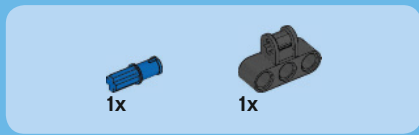
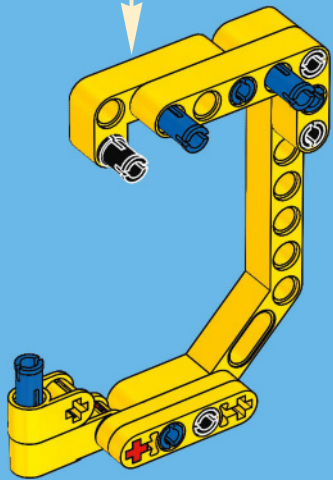
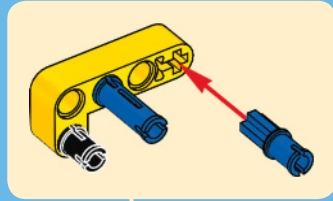

6

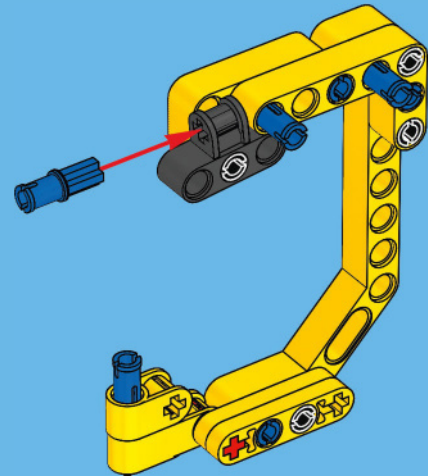



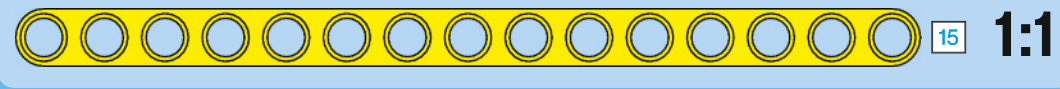
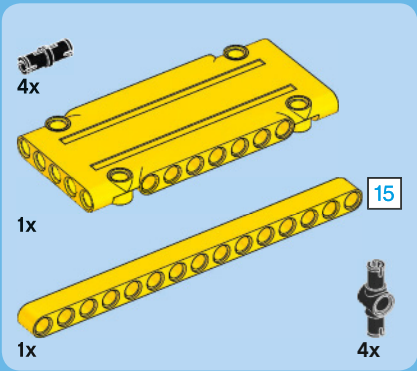

7

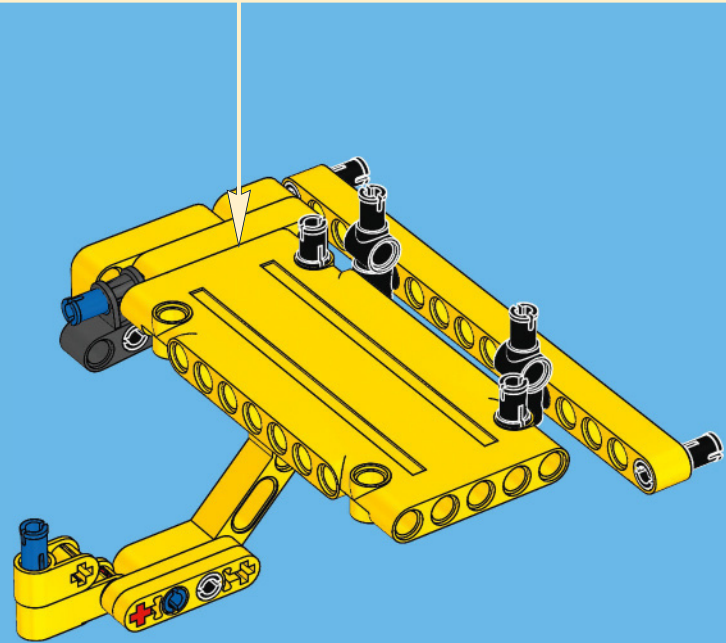
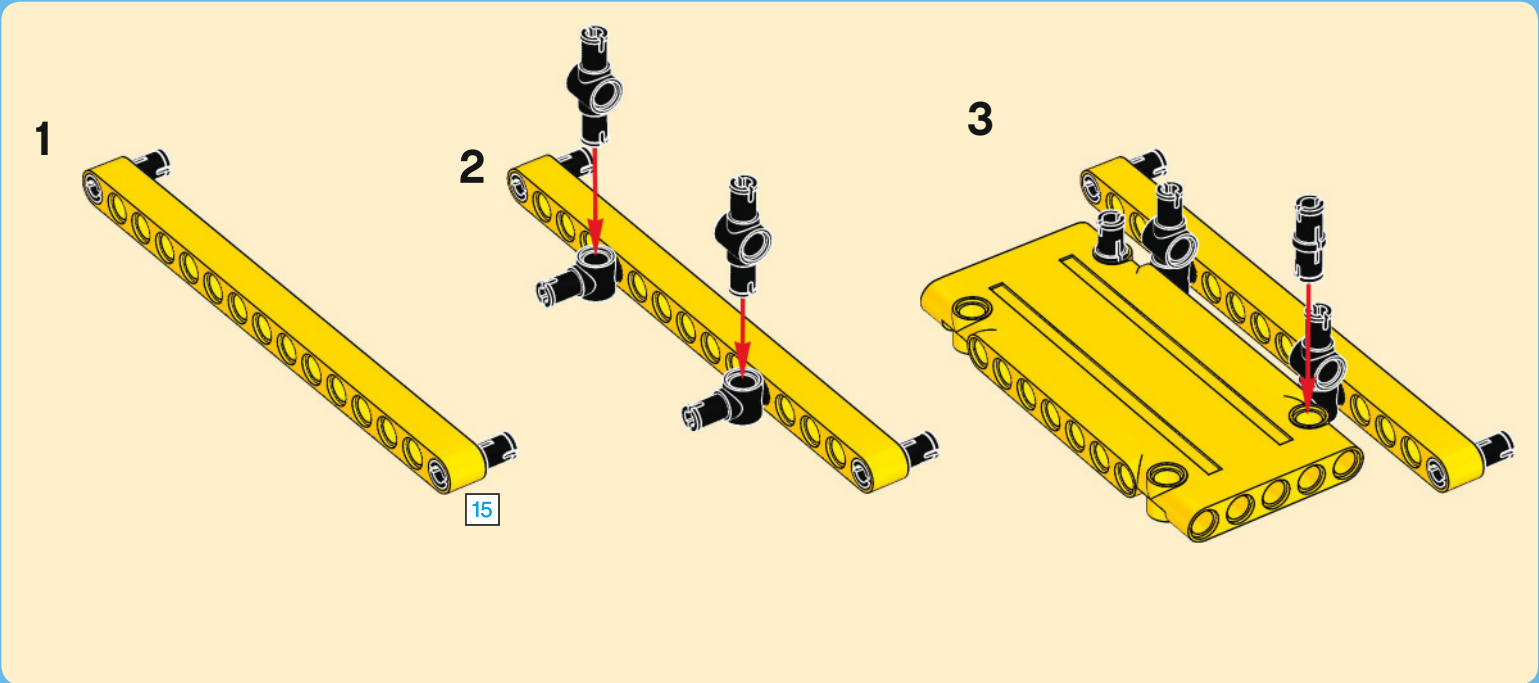

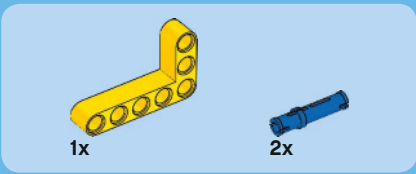

8

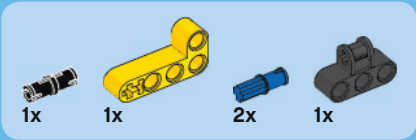
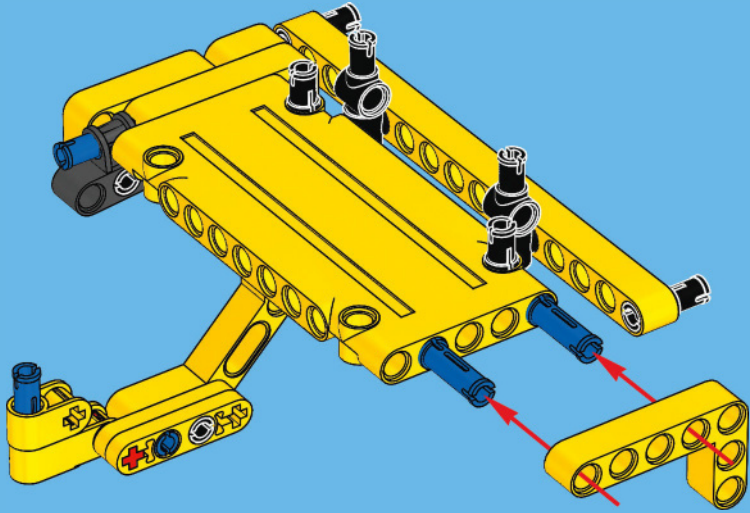

9

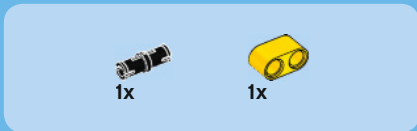
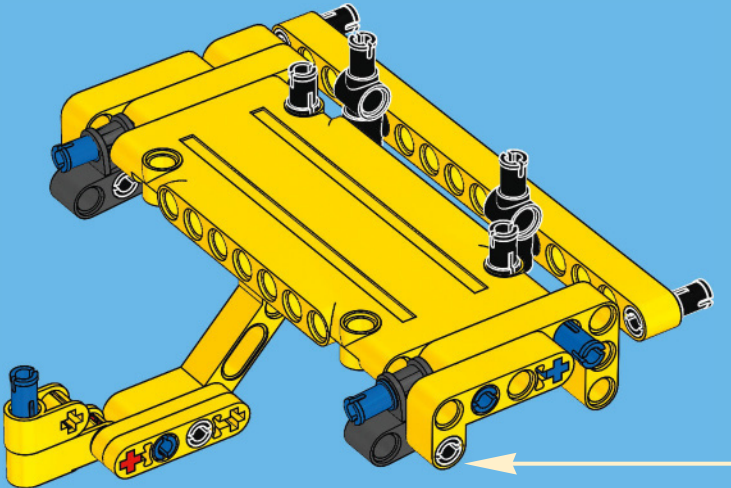
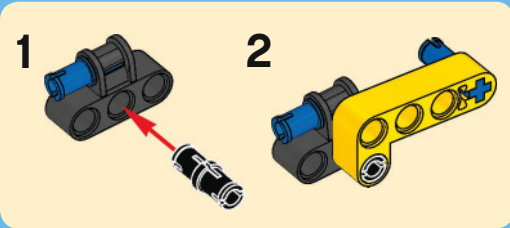

10

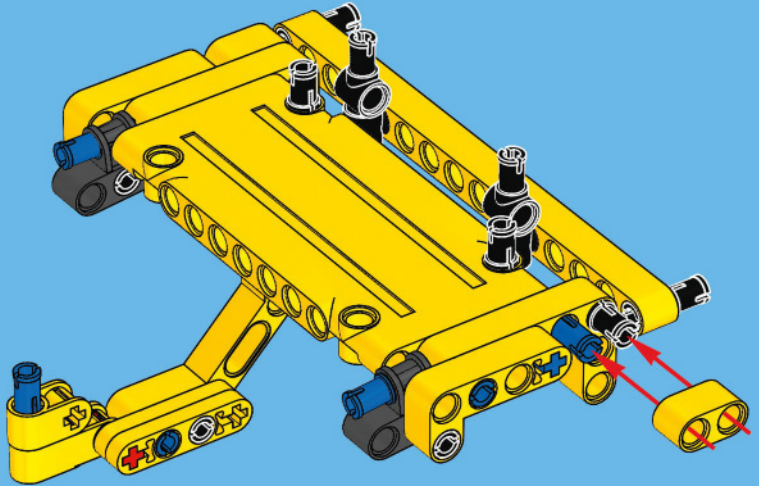



11

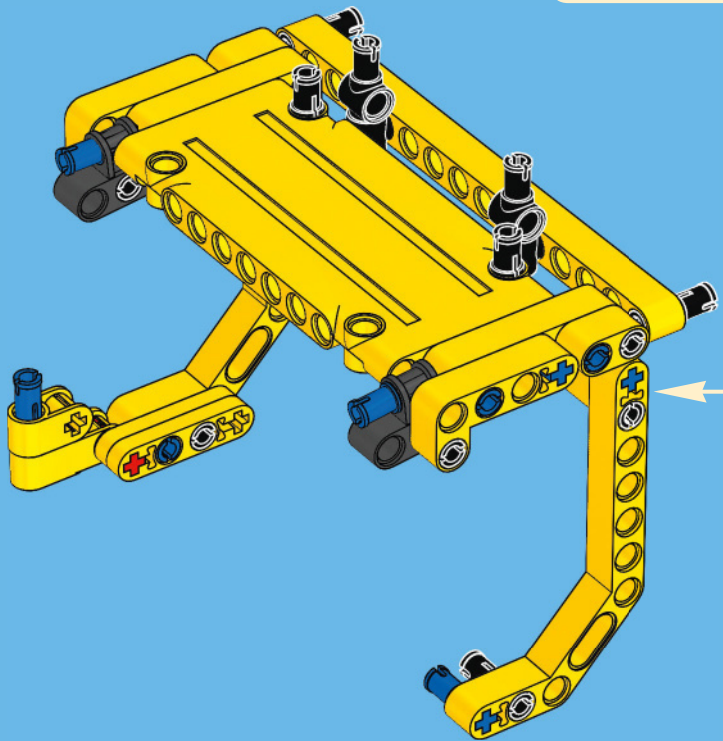
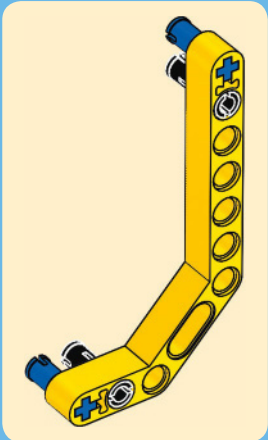
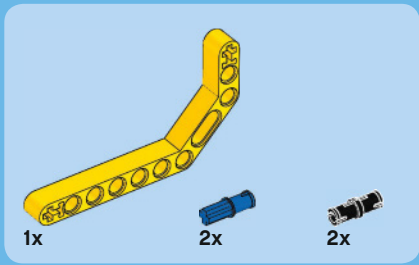

12

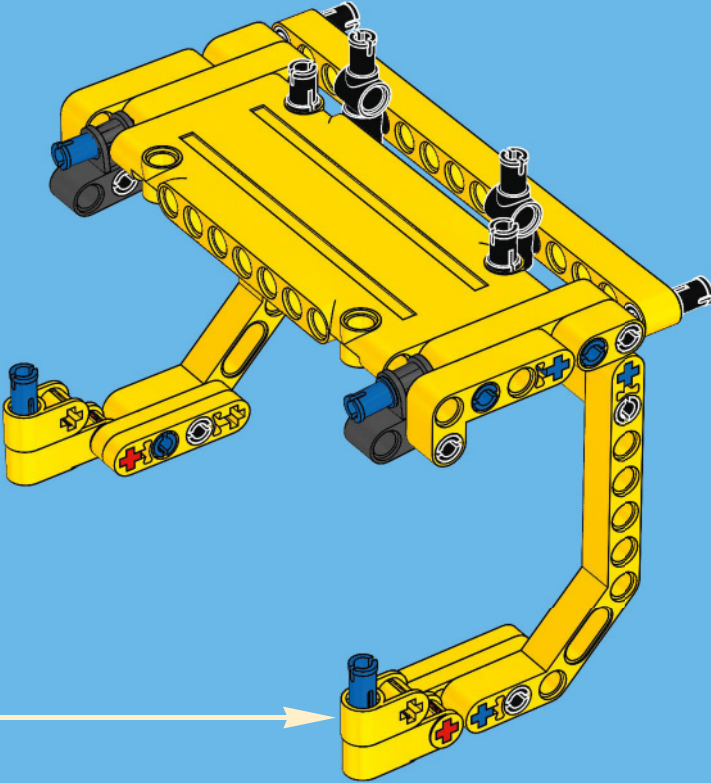
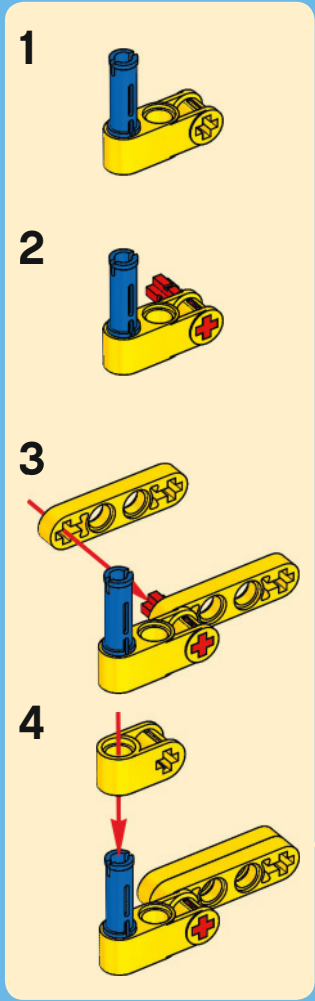
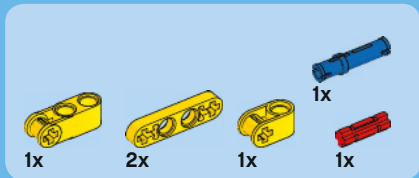

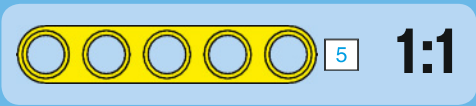
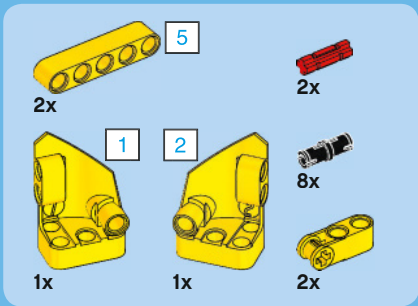

# 13

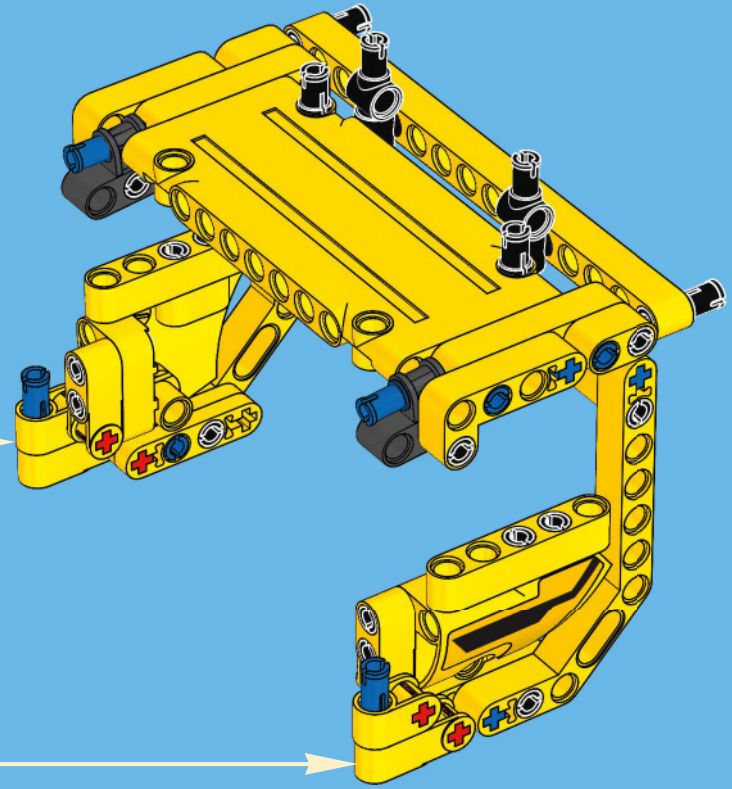
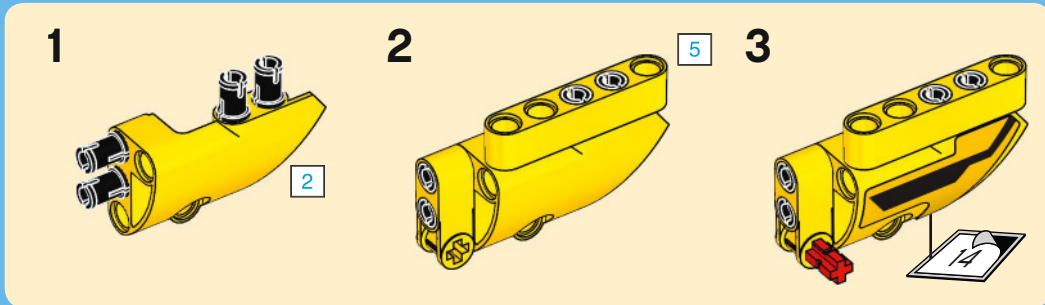
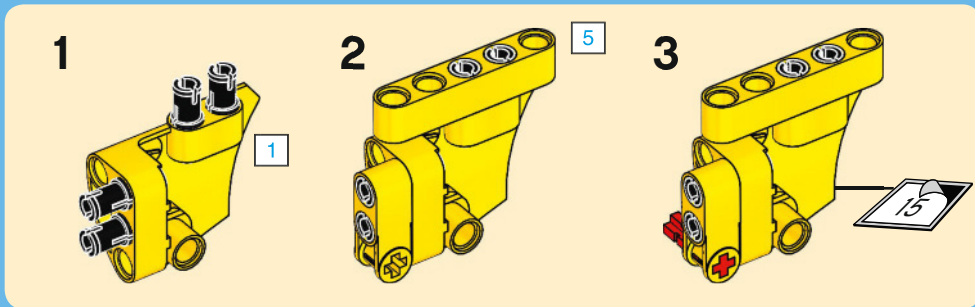



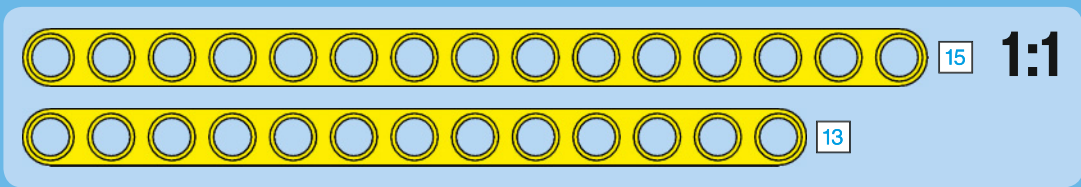
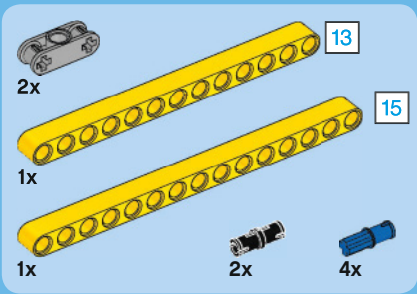

14

1

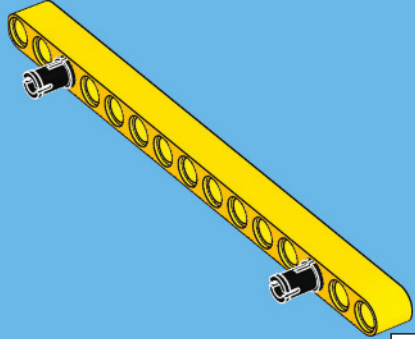

2

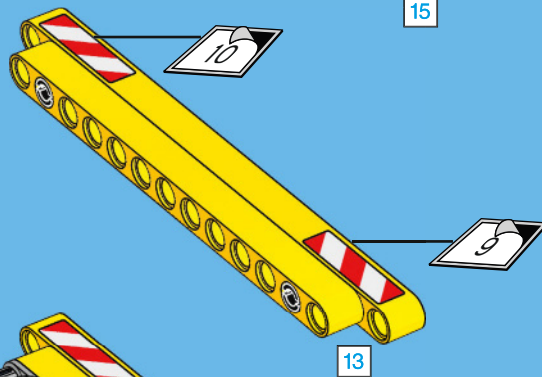

3

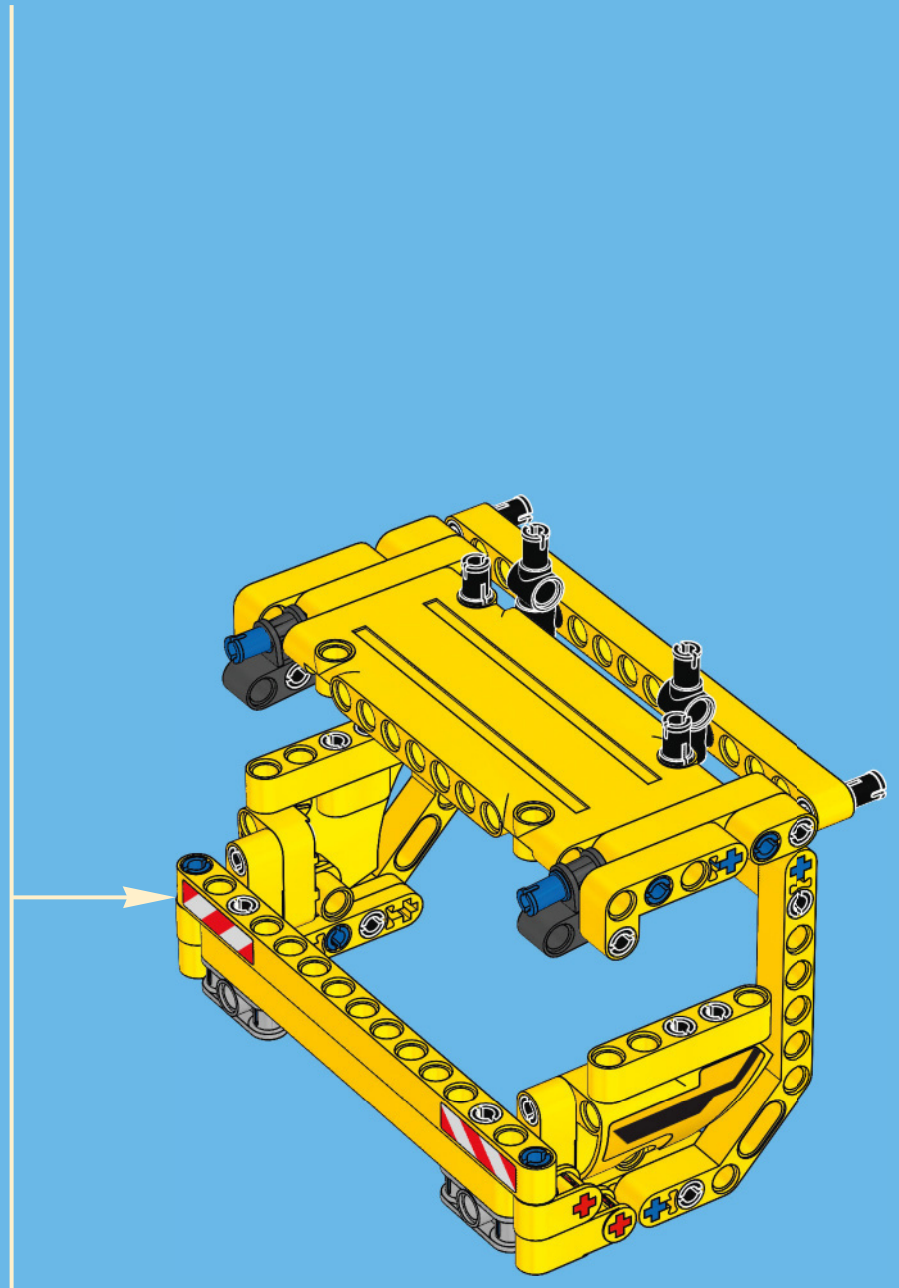
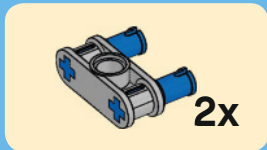
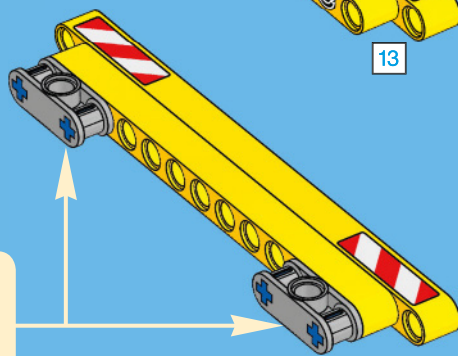

145

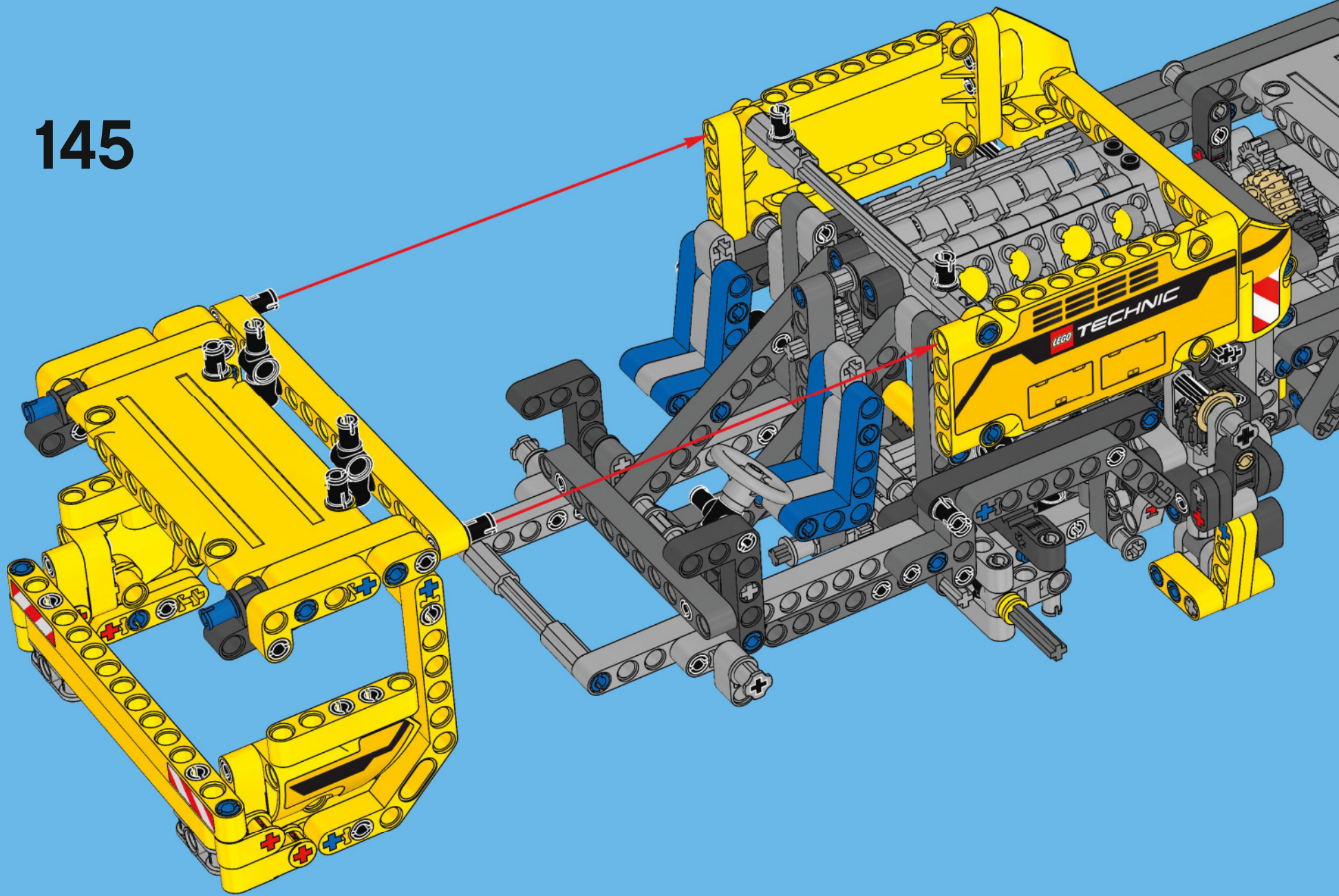





2x

# 146

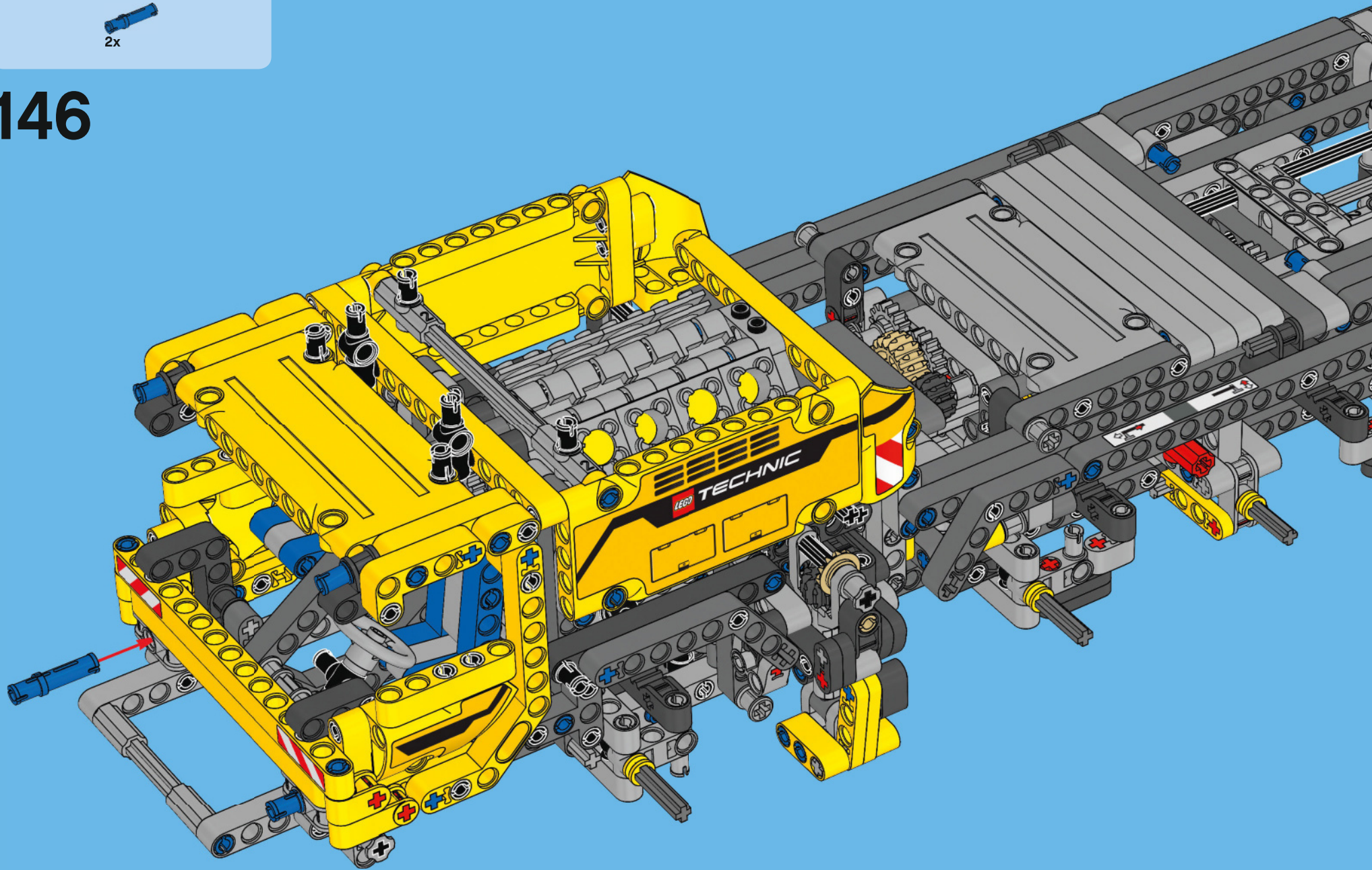



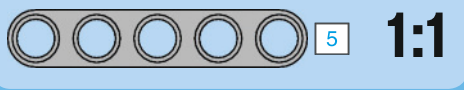
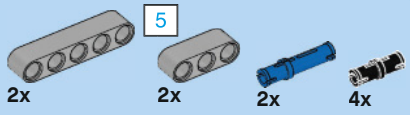

# 147

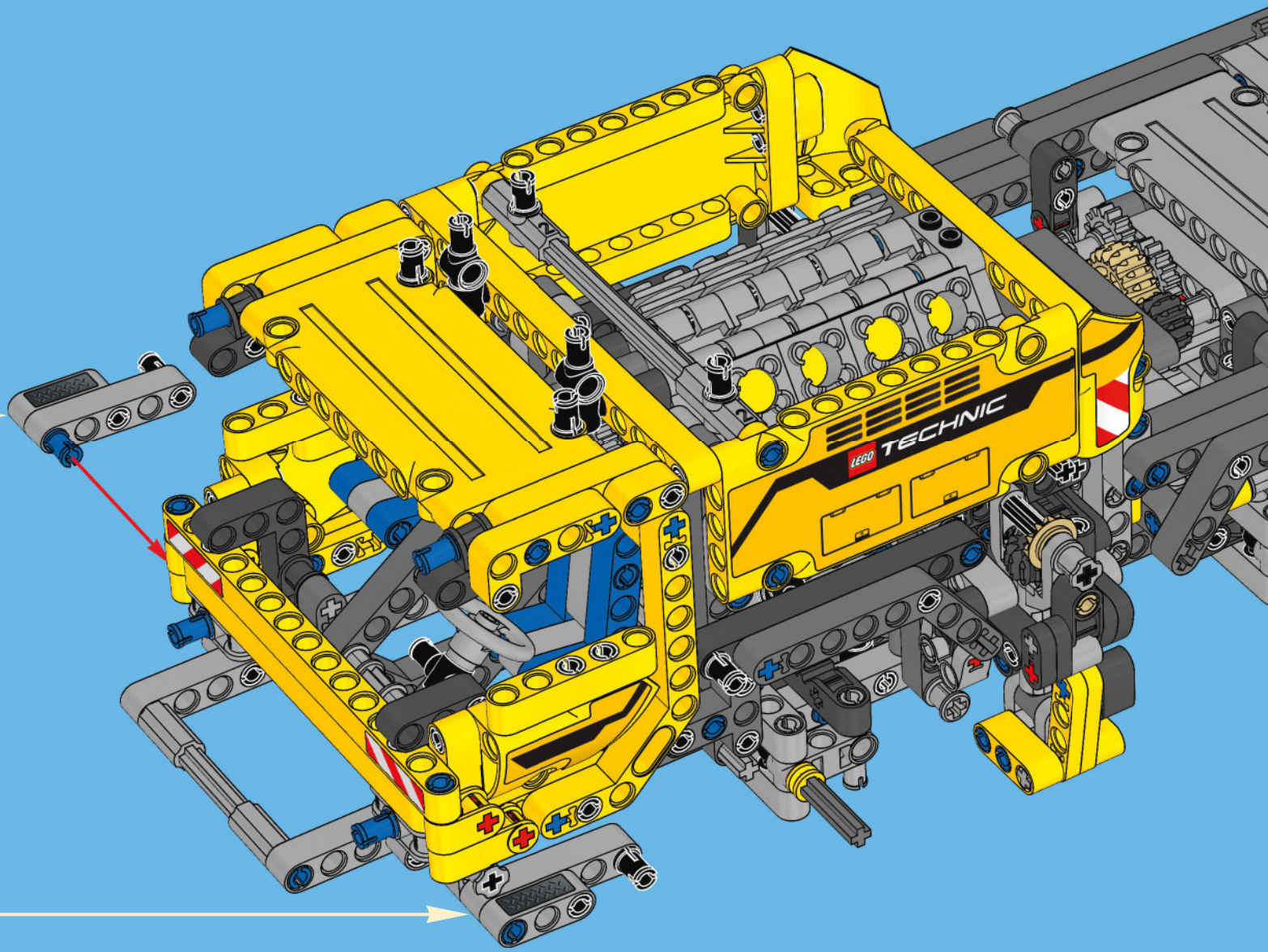
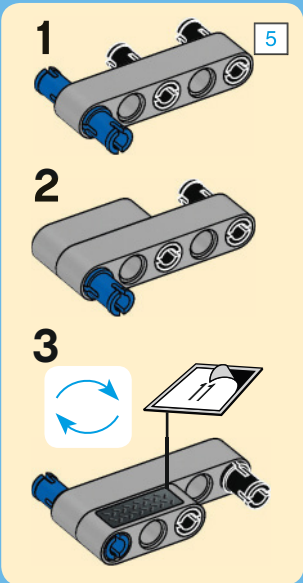
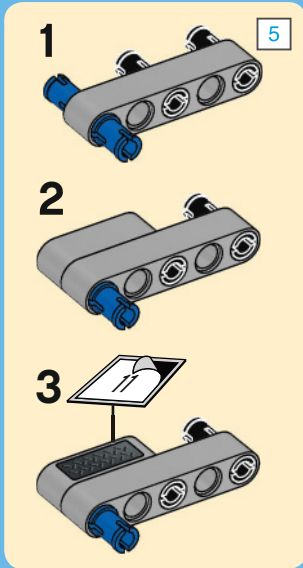



# 148

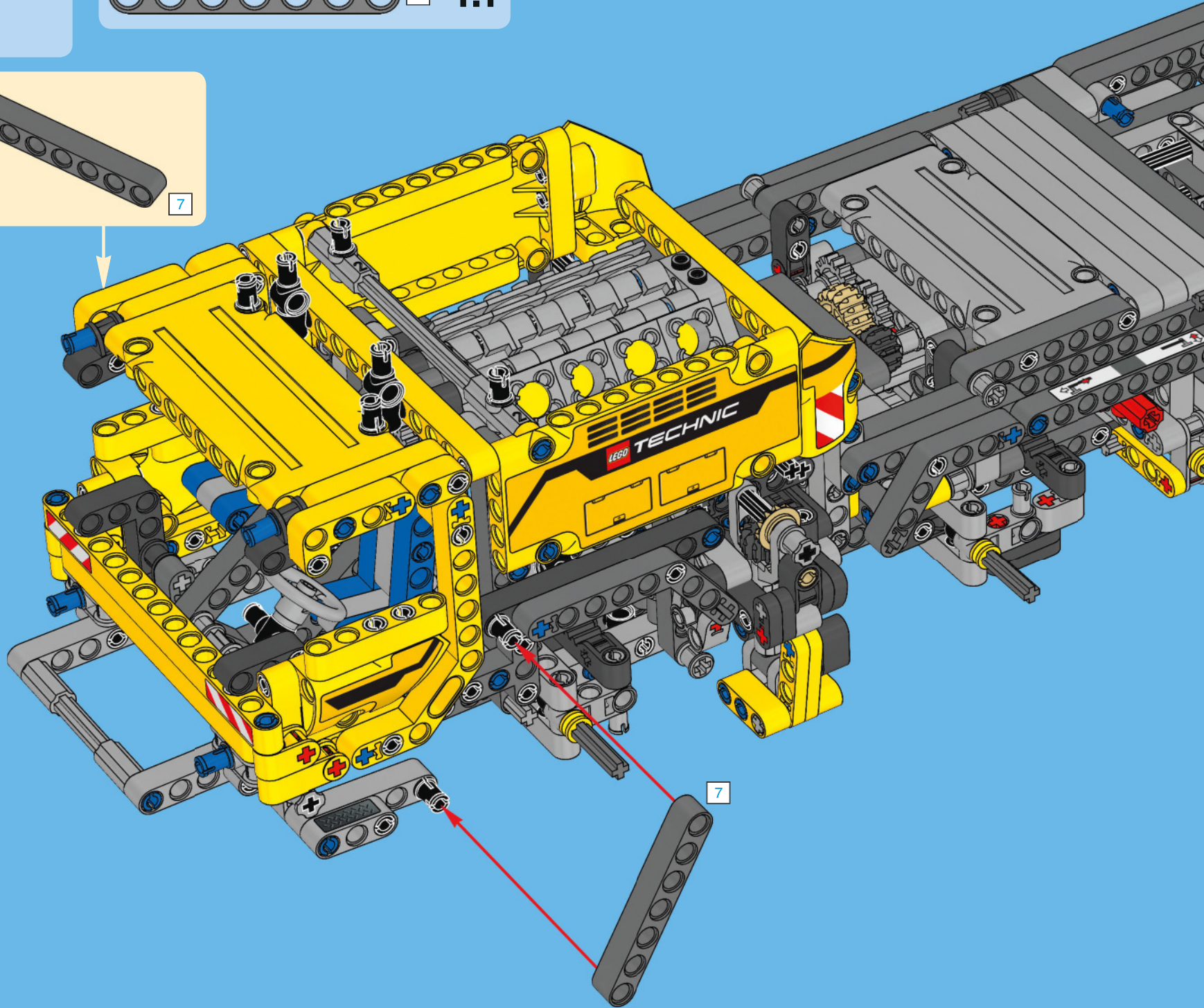
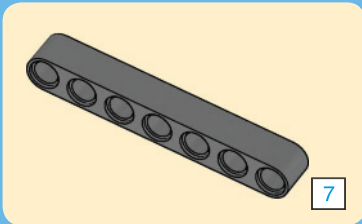
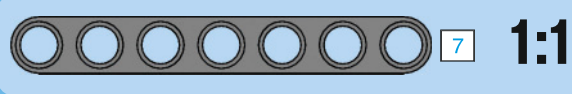
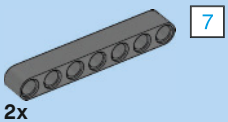



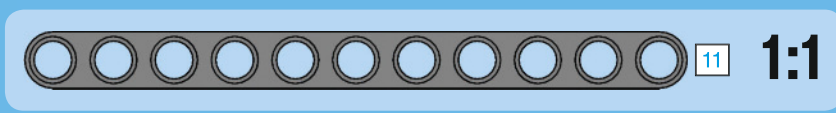
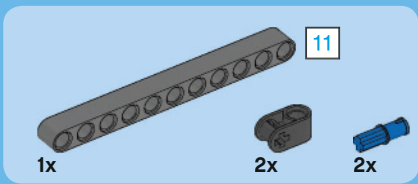

# 149

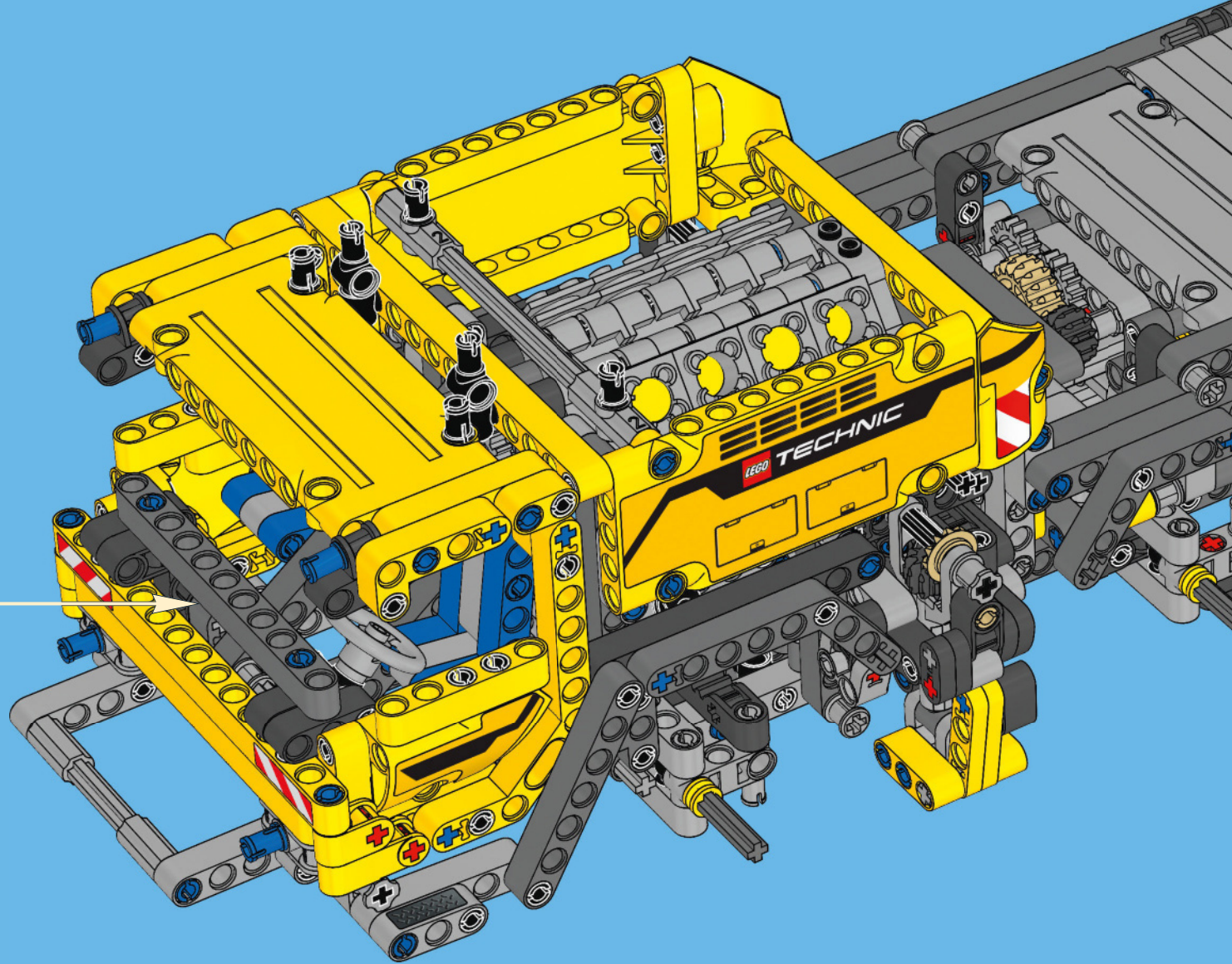
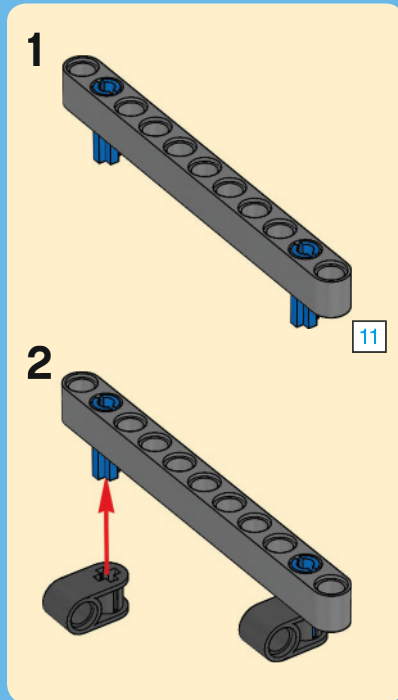



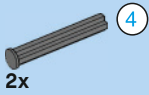

# 150

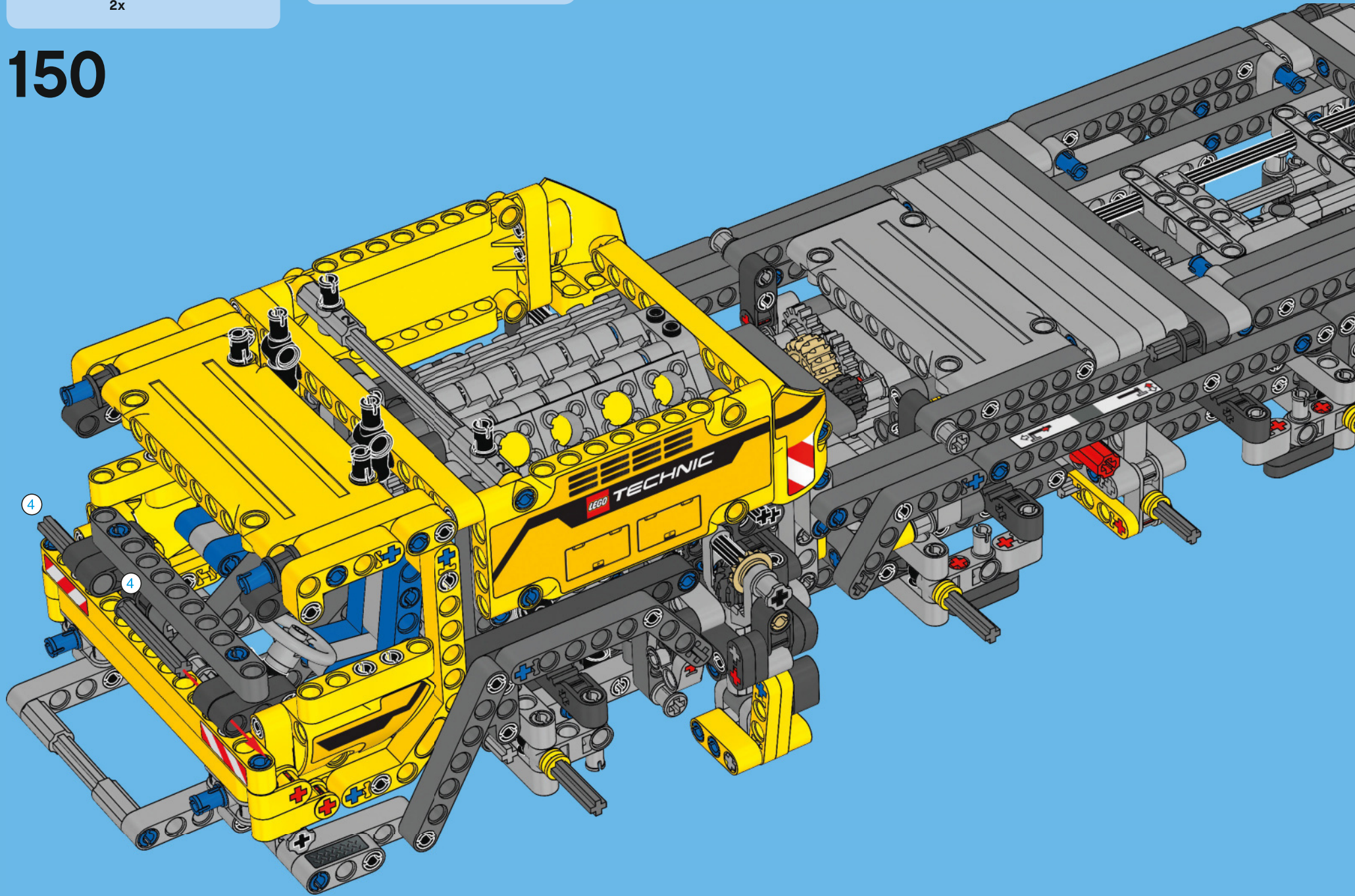



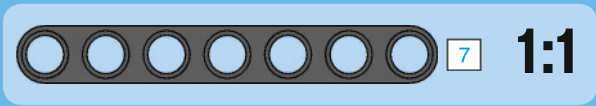
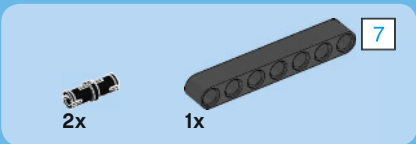

# 151

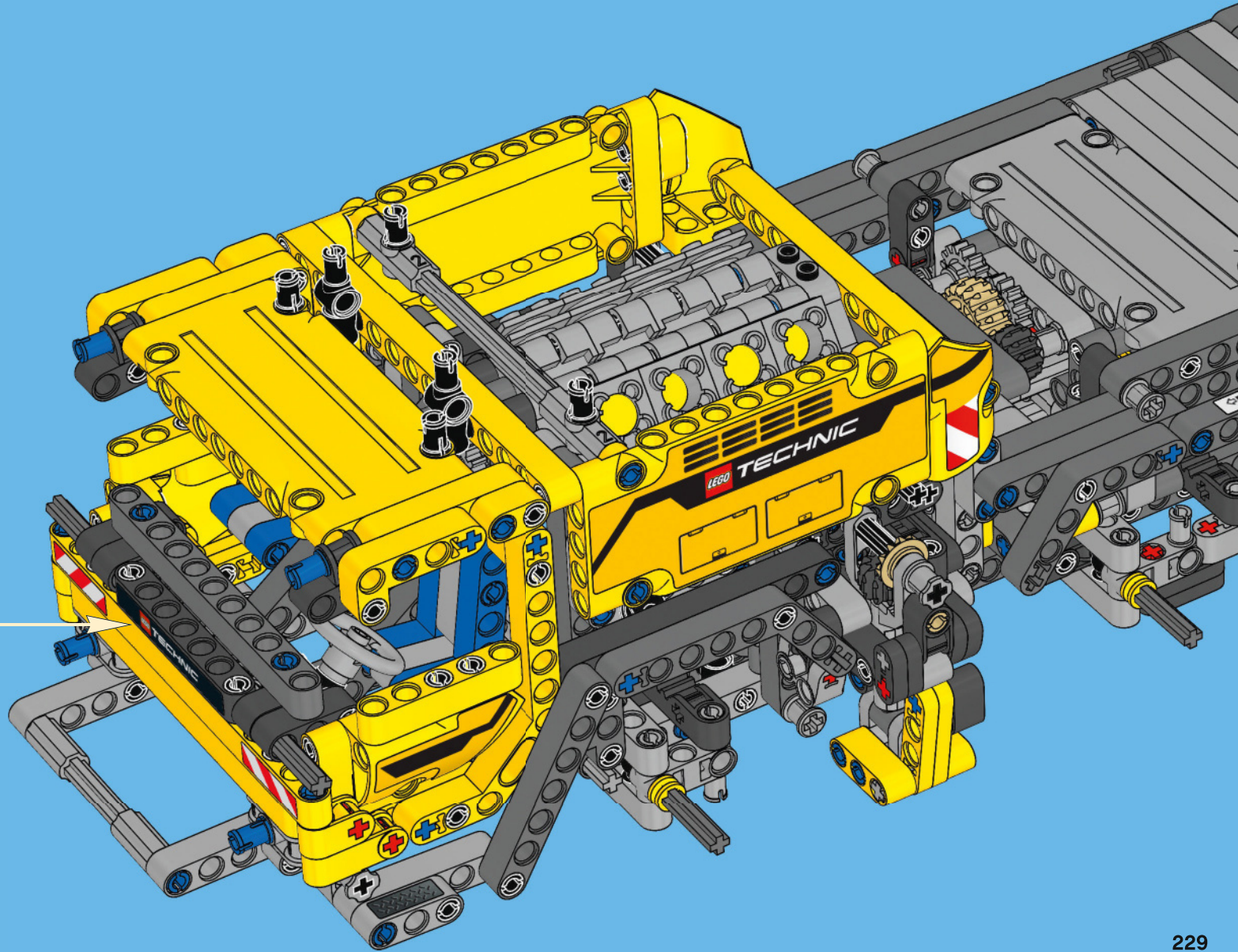
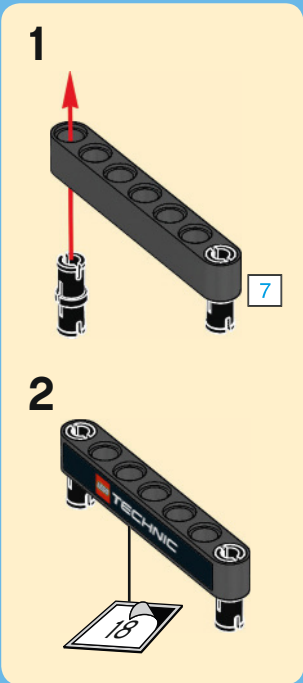



-  2x
-  2x
-  2x
-  4x

# 152

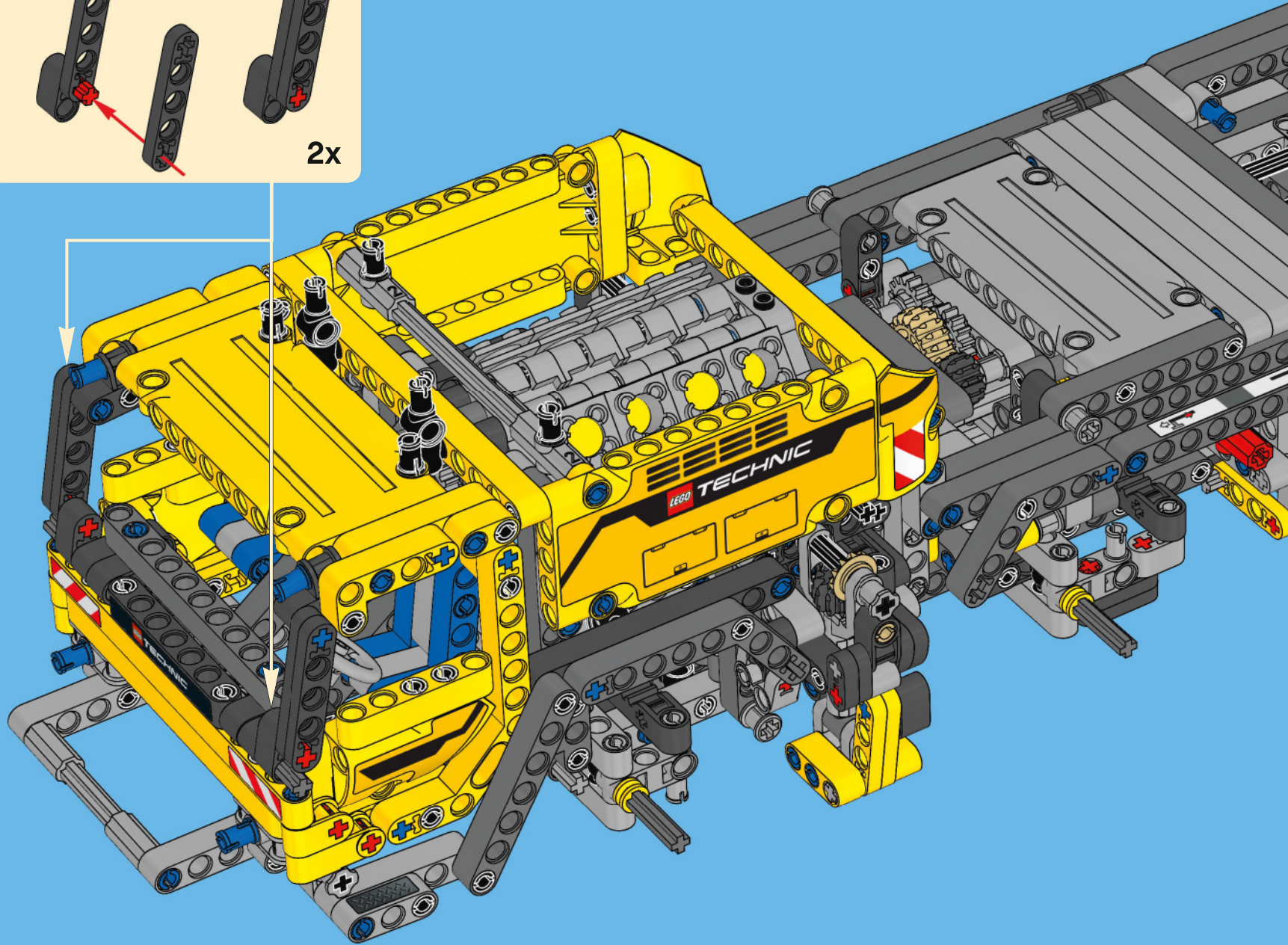
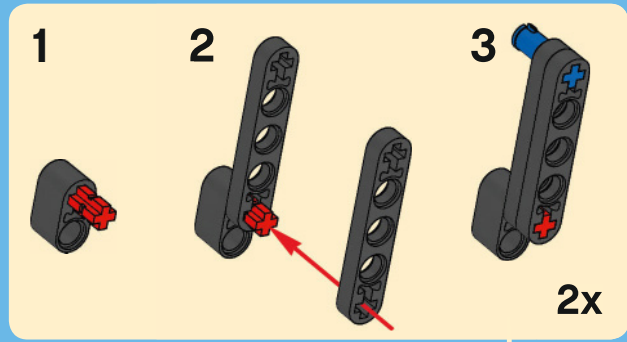



4x

# 153

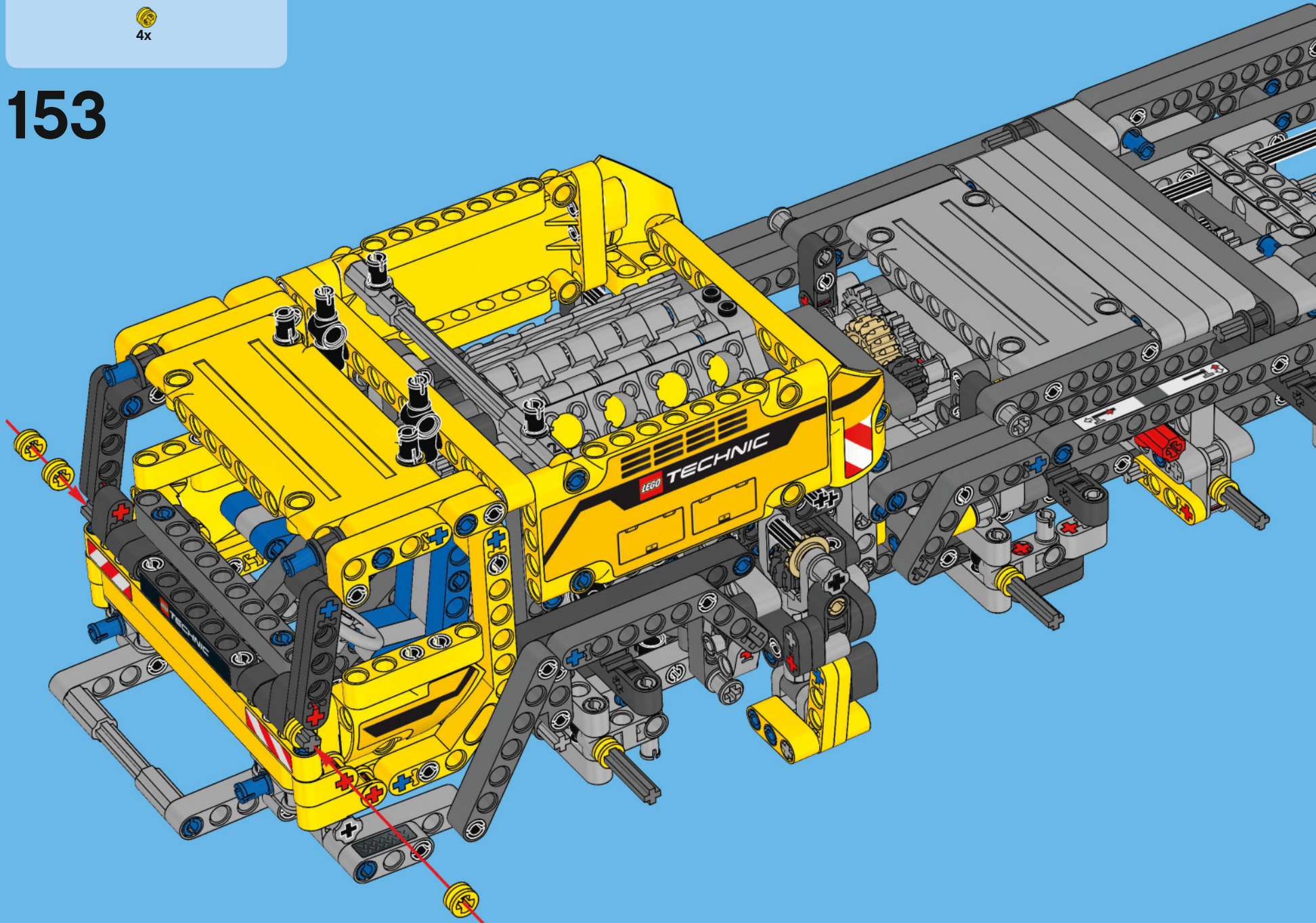



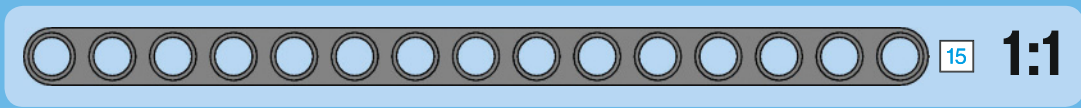
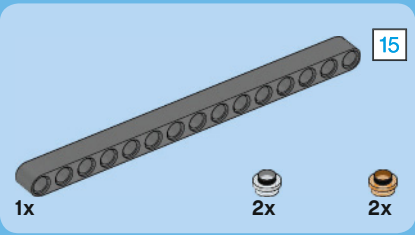

154

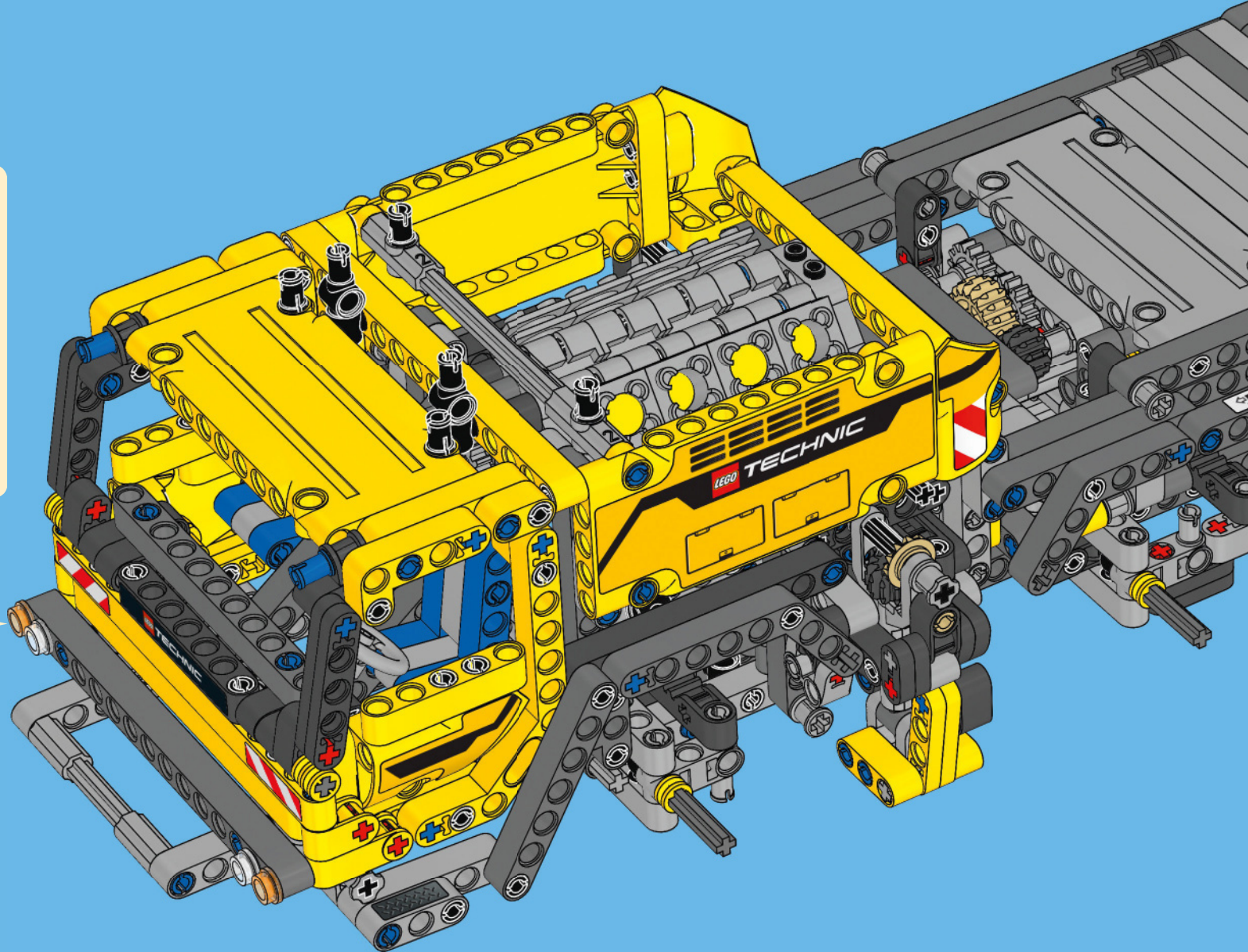
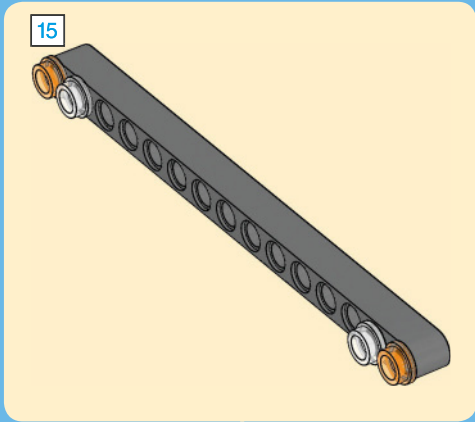



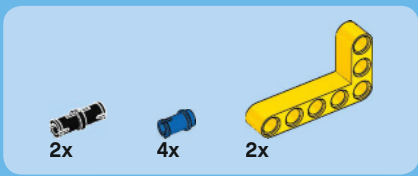

# 155

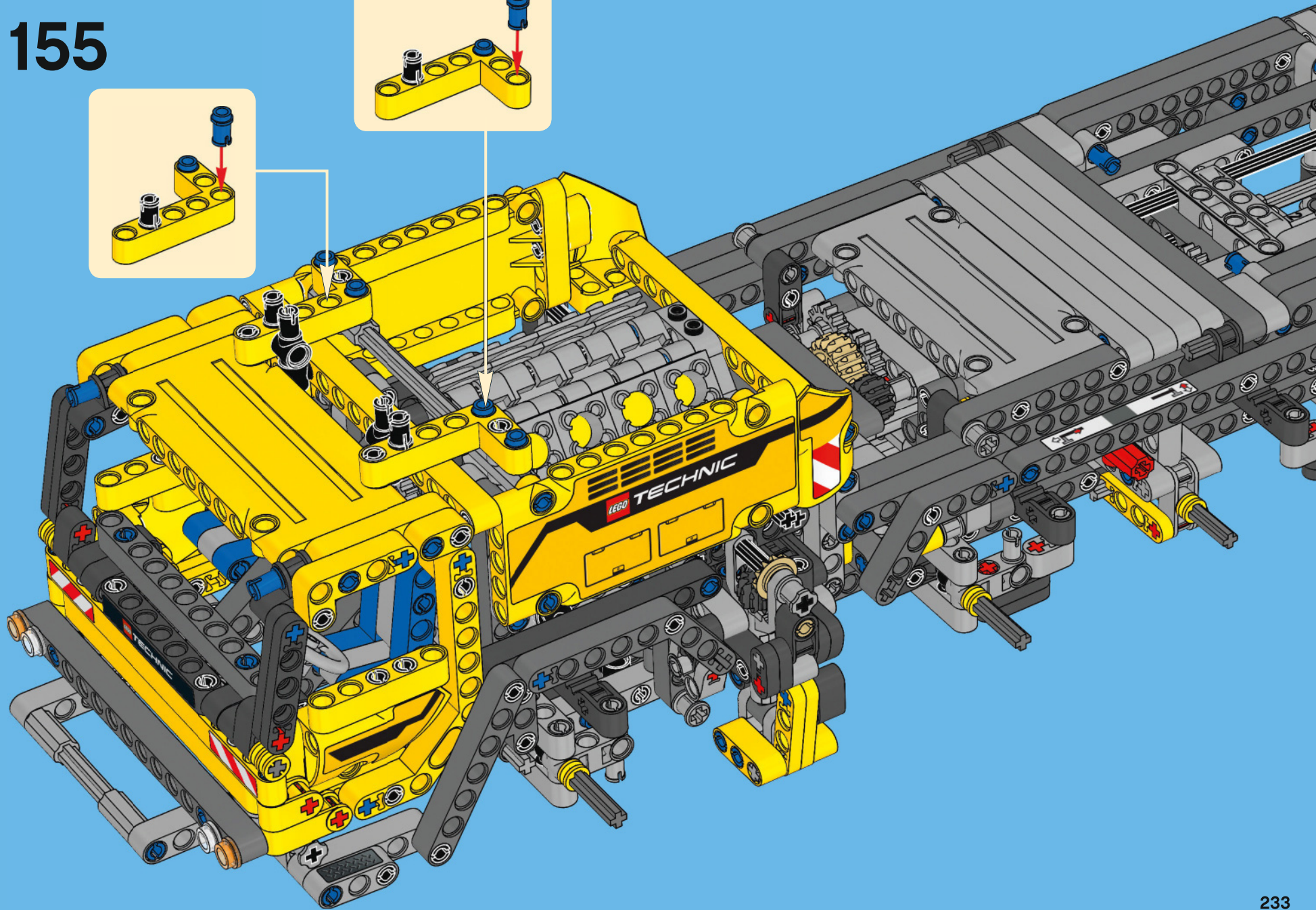
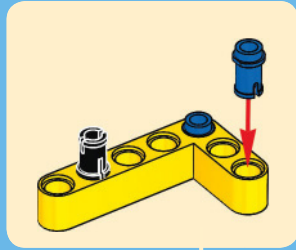
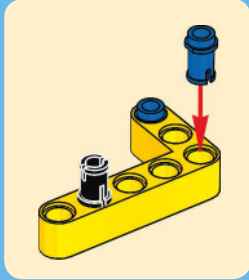



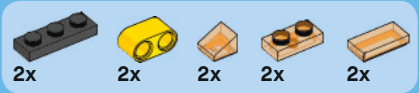

# 156

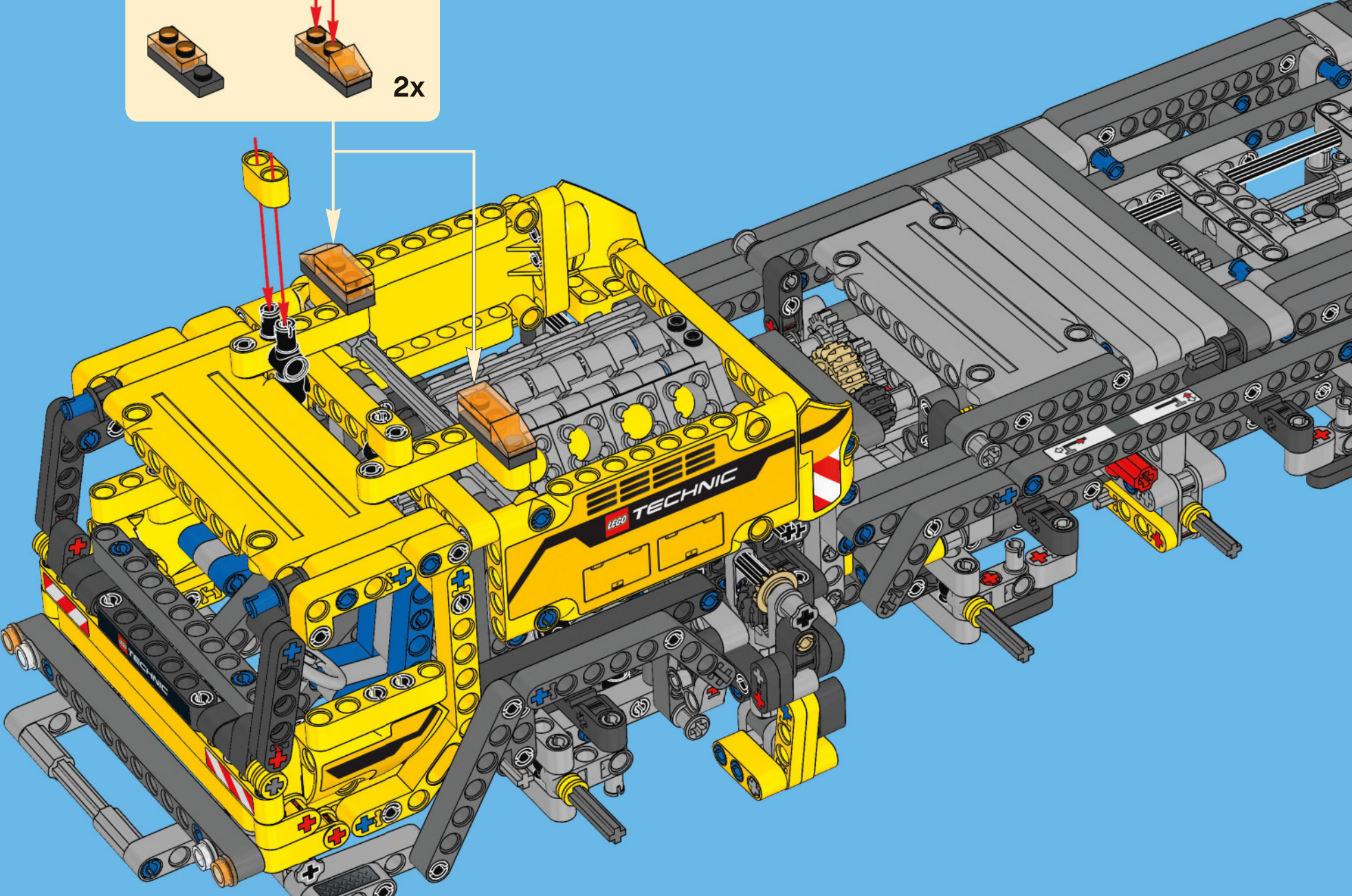
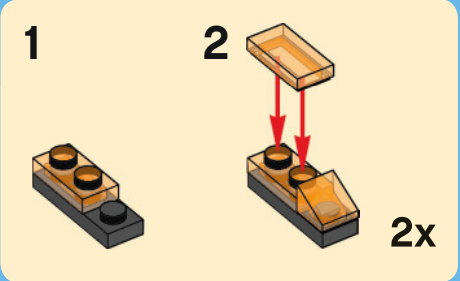



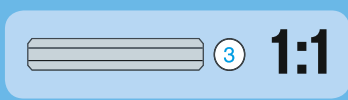
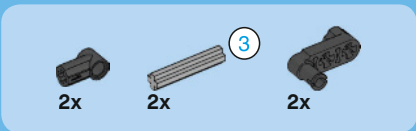

# 157

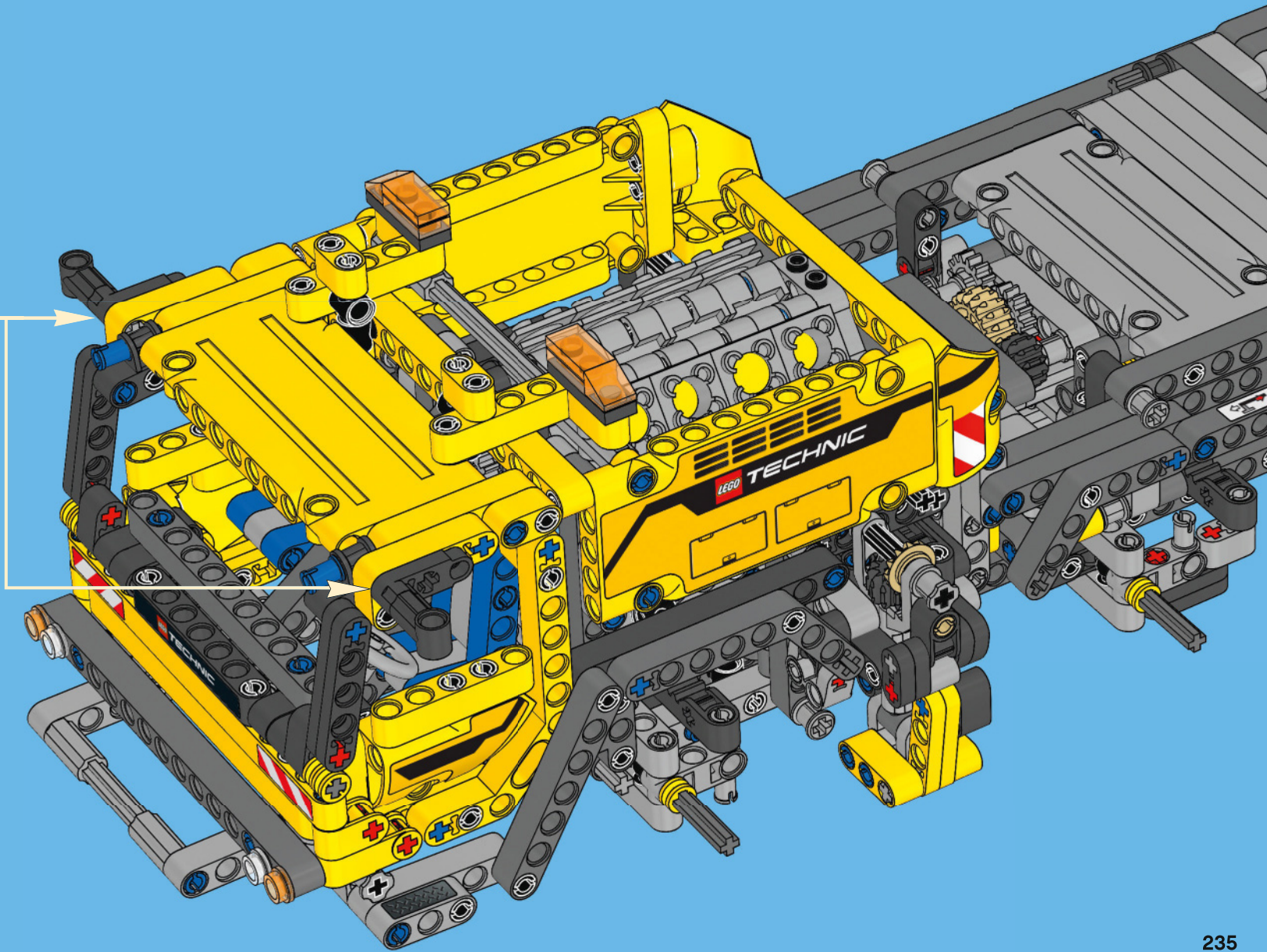
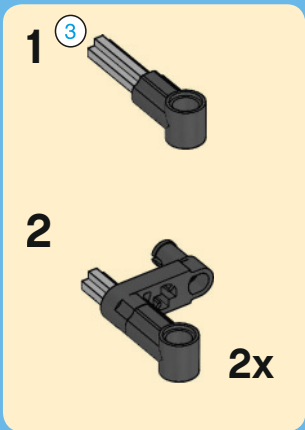



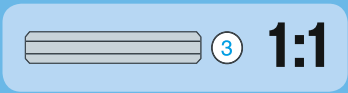
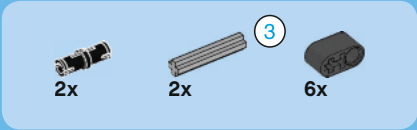

# 158

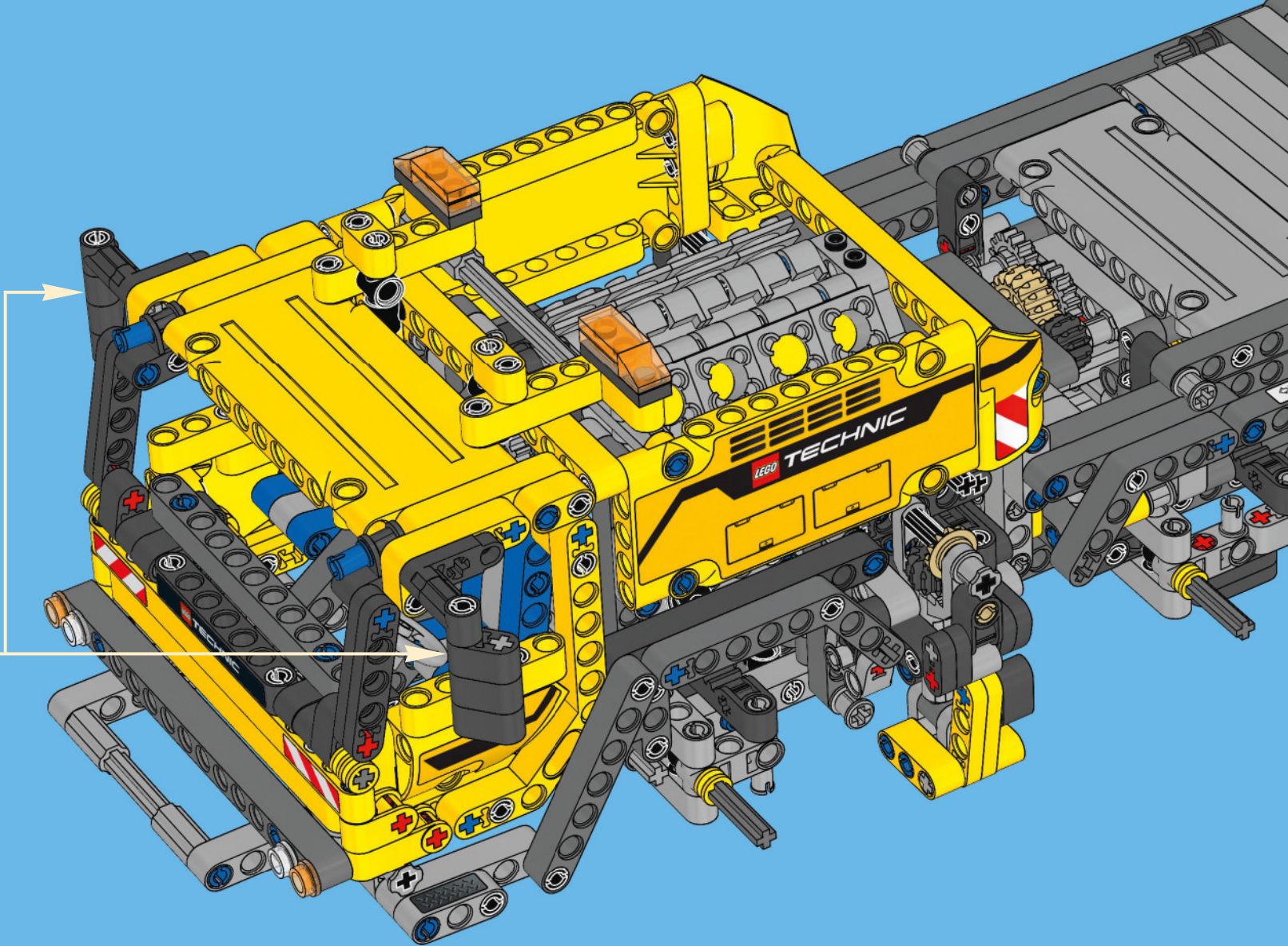
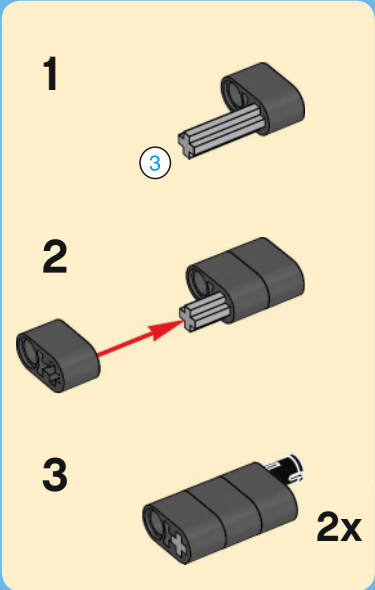



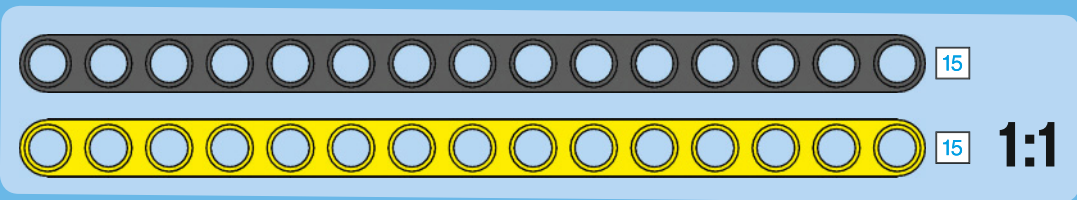
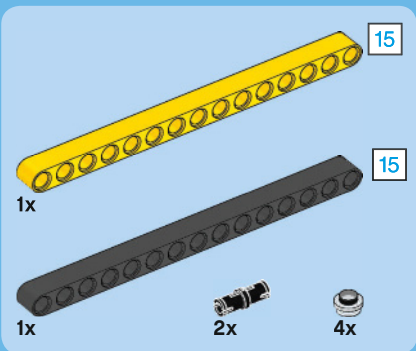

# 159

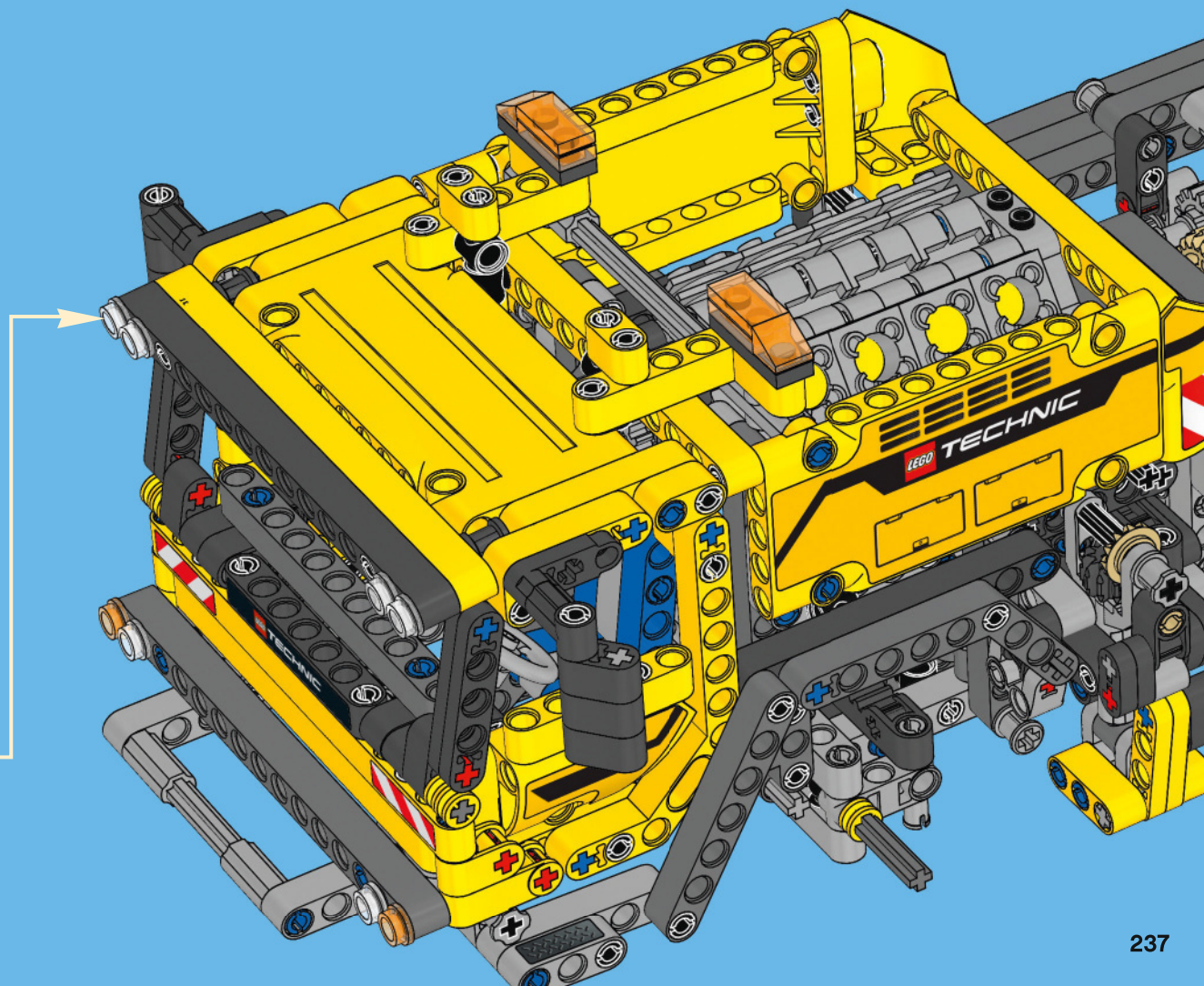
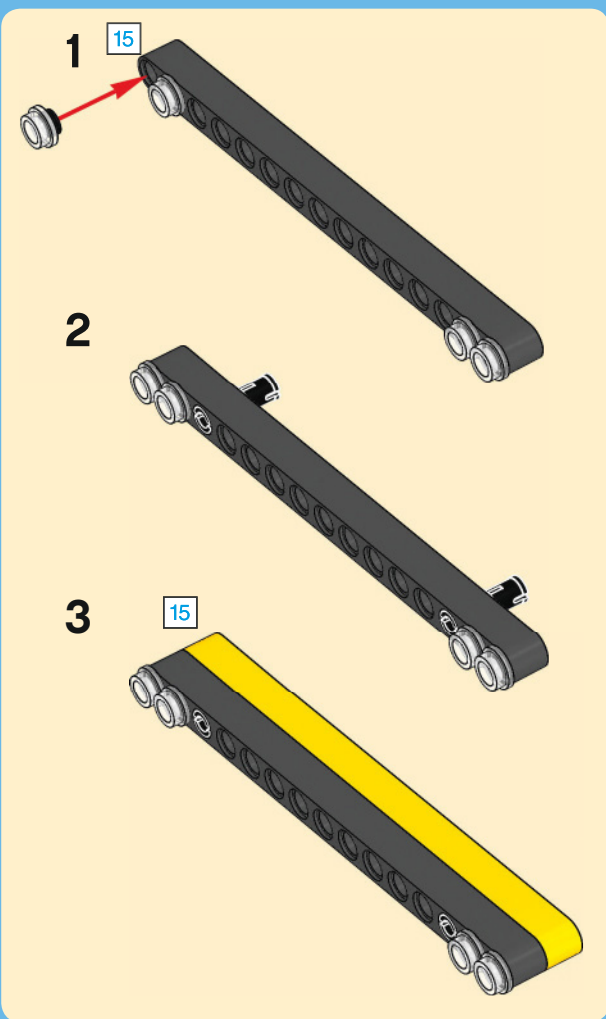





10x

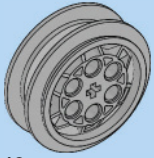

10x

# 160

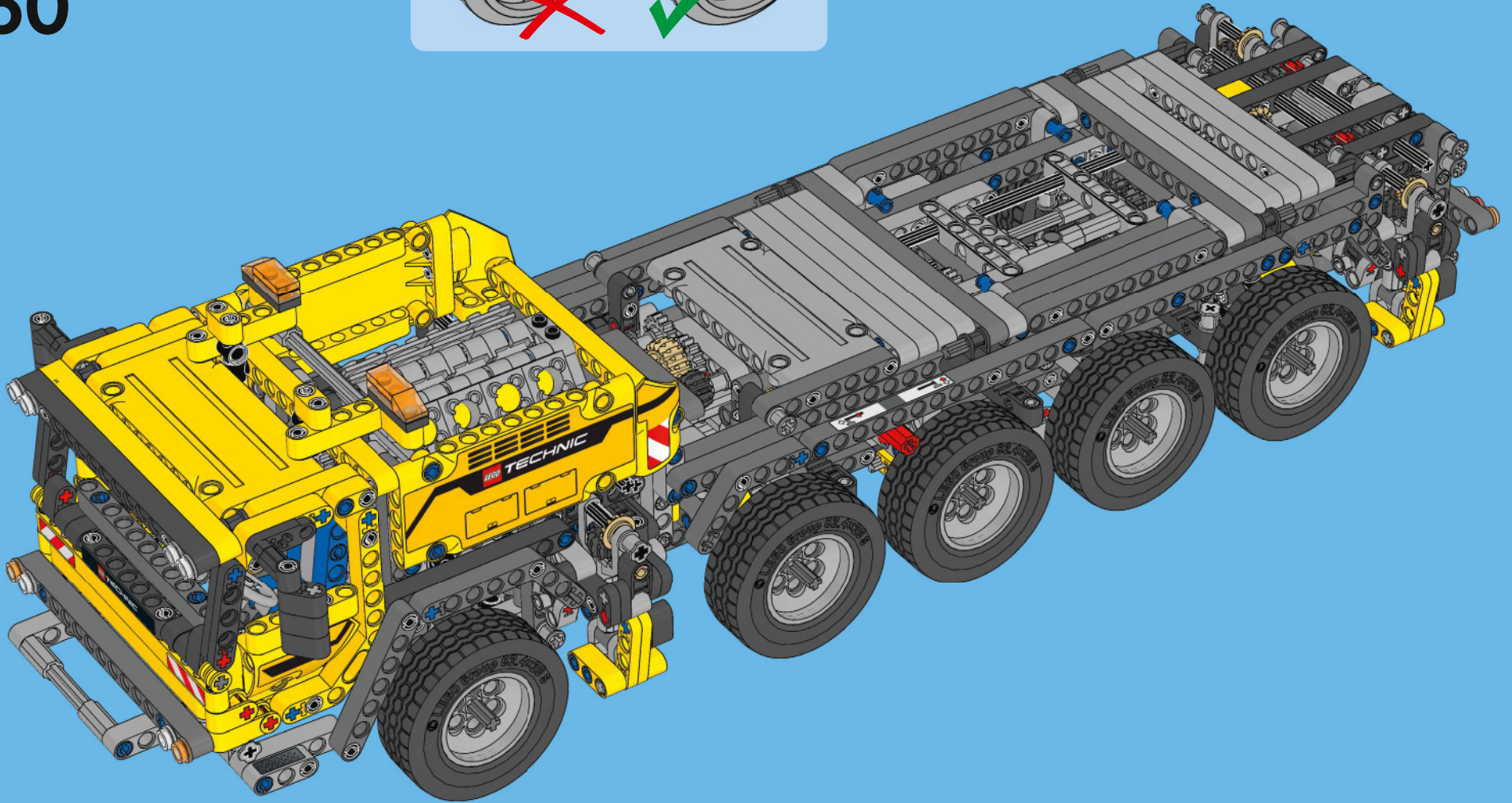
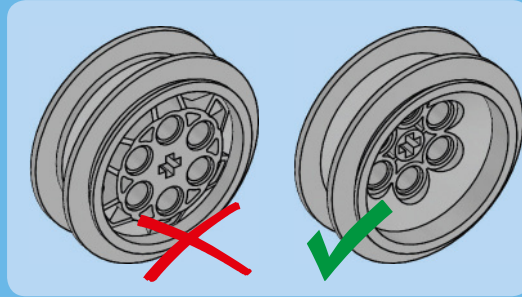





10x

# 161

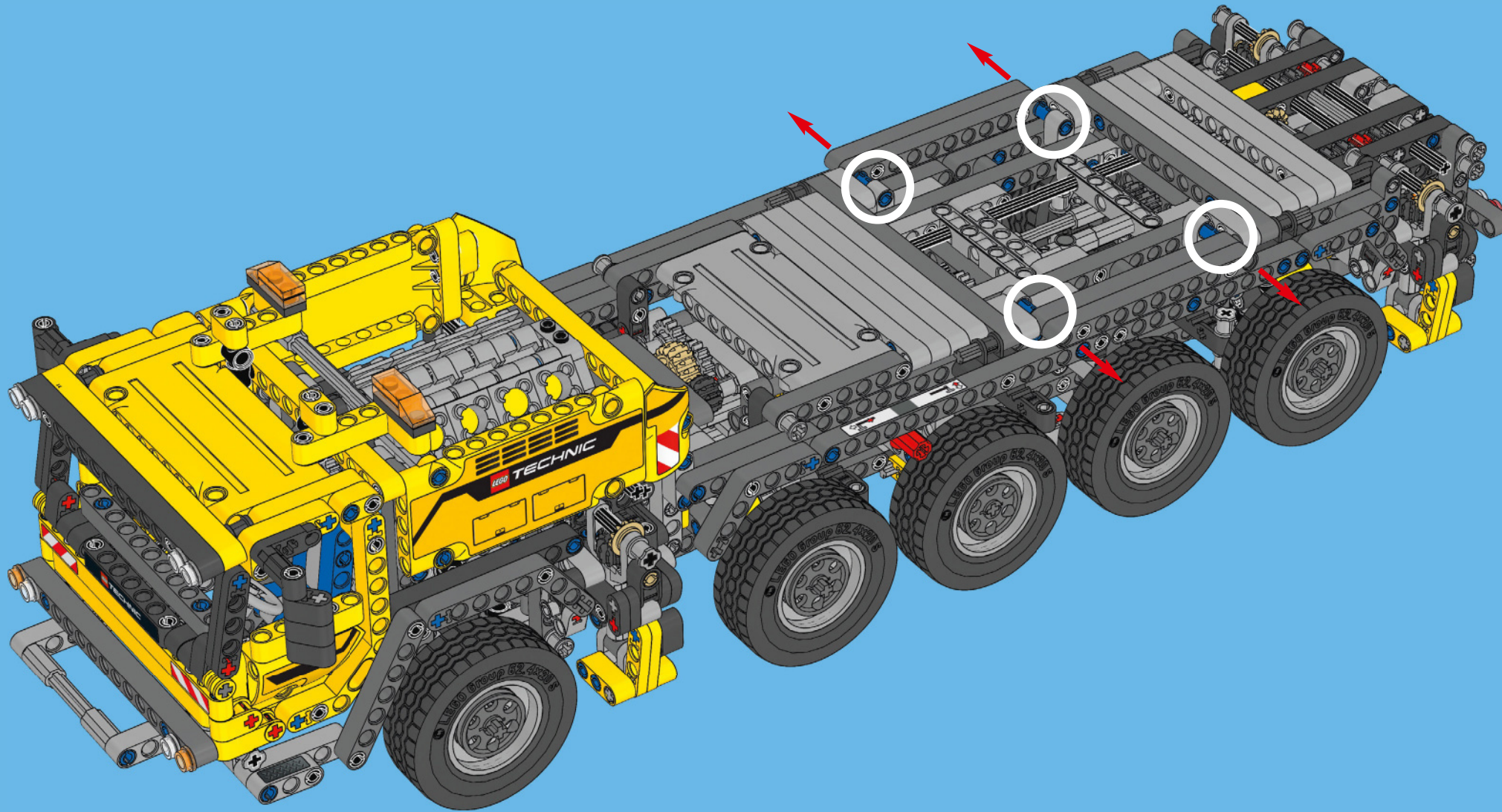



5x

2

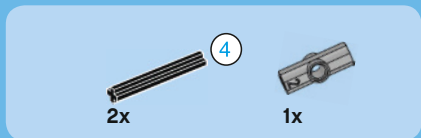
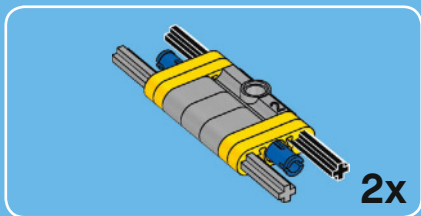
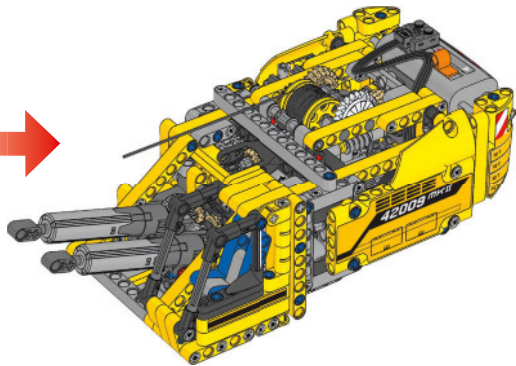

1

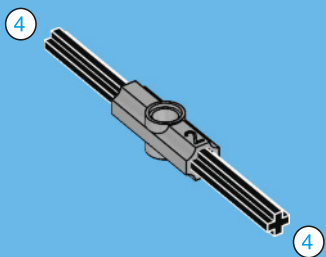

2x

2

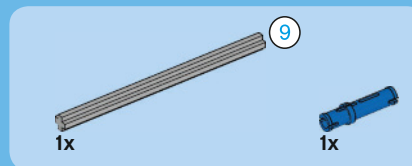
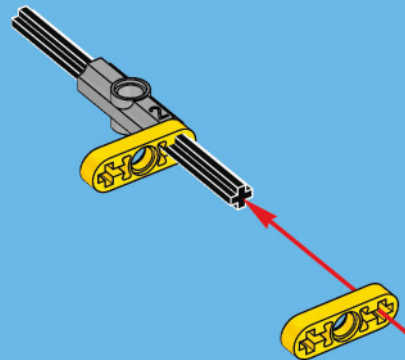

3

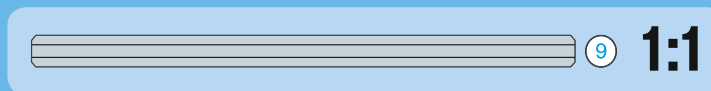
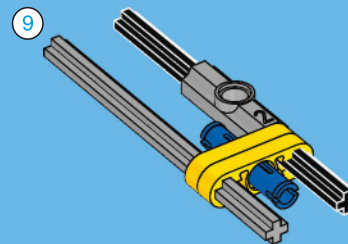



3x

4

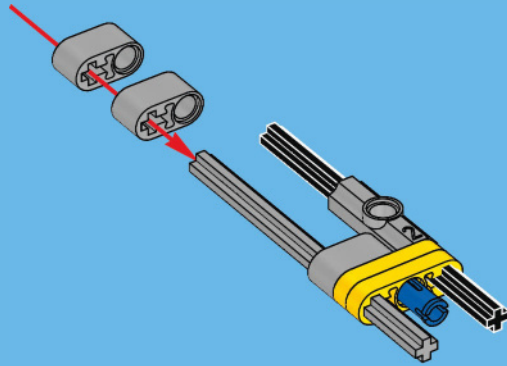

1x

6

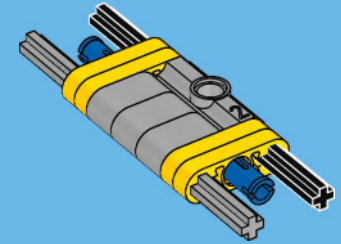

2x



2x

5

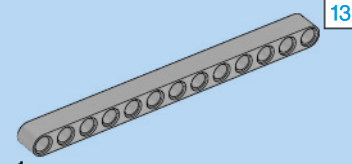
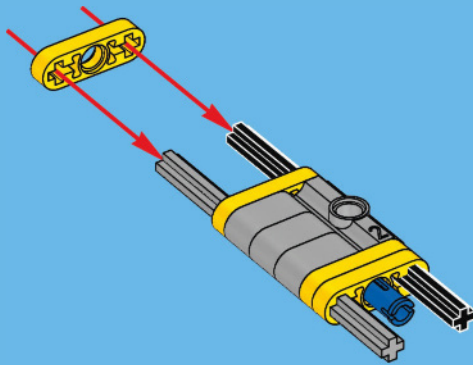

1x

13

7

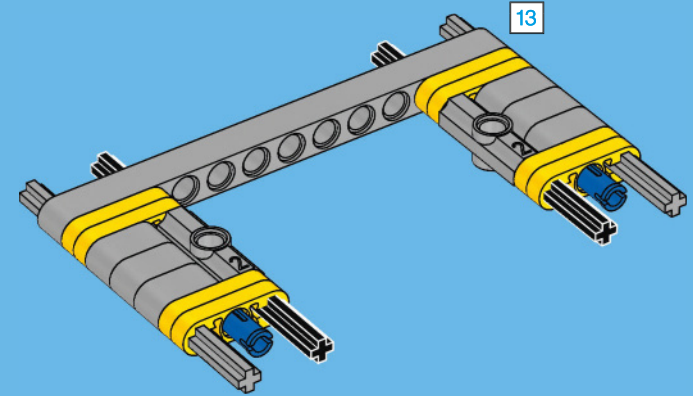

13



13

1:1





2x



2x

# 8

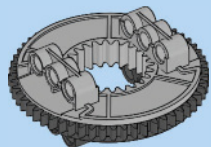
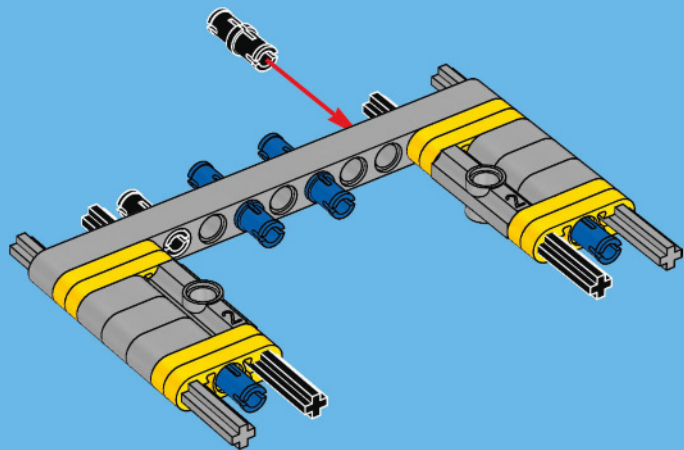

1x

# 9

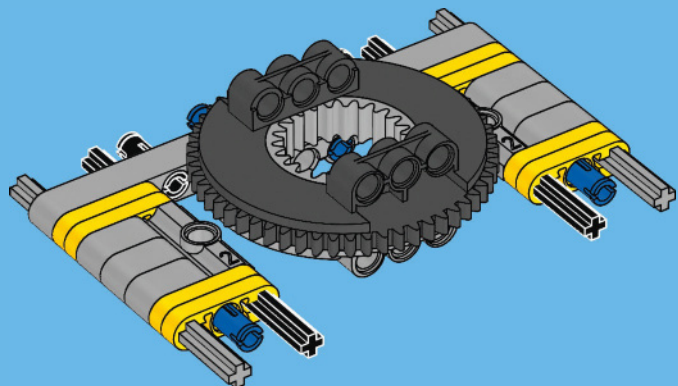

13

# 1:1

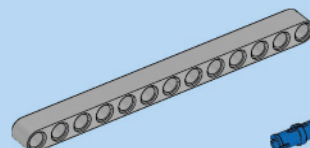

1x



2x

# 10

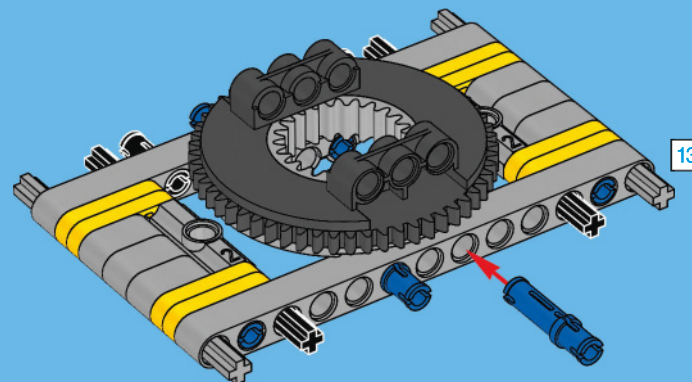

13



2x

# 11

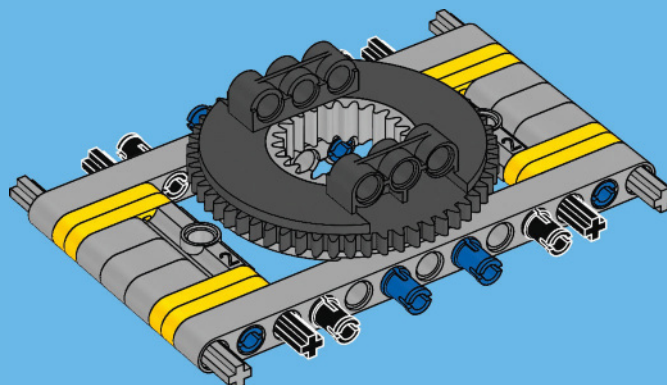

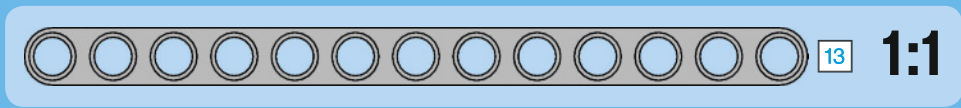
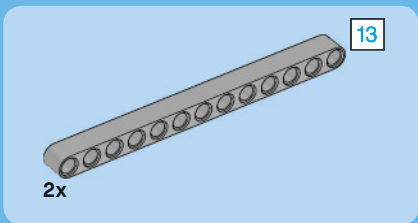

12

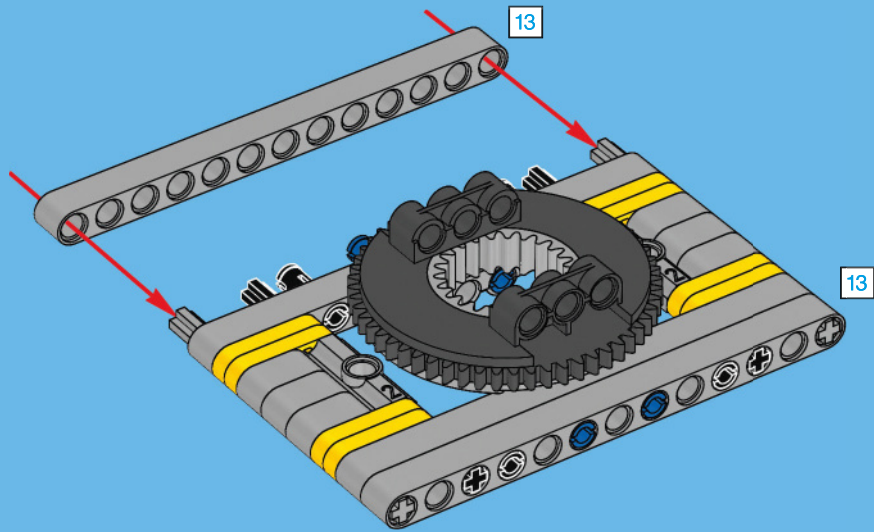

13

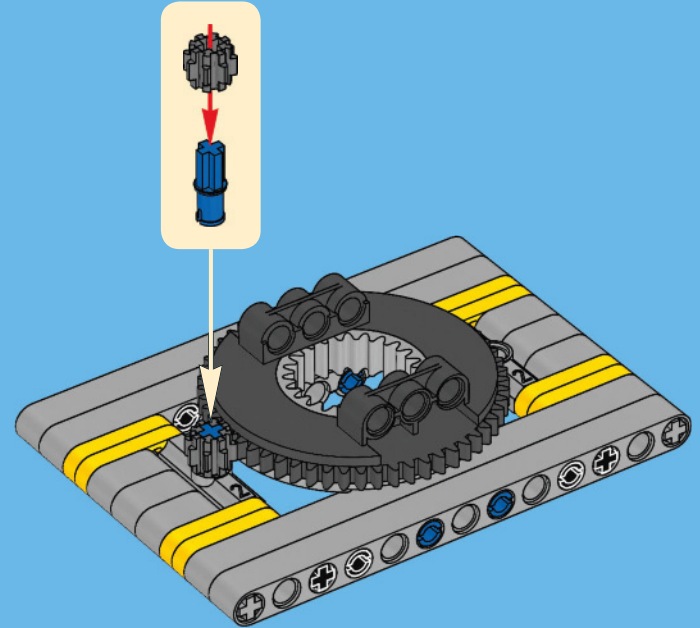

14

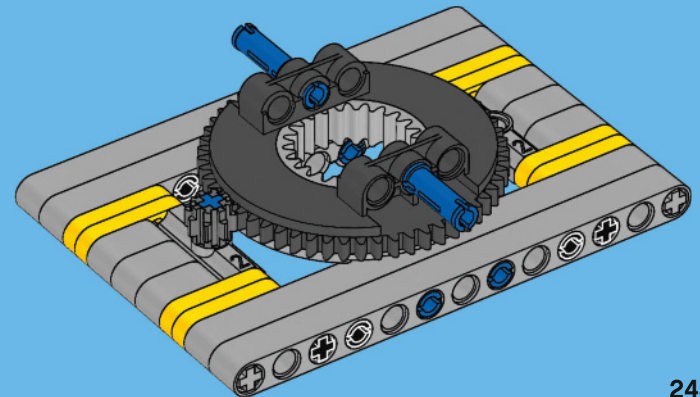



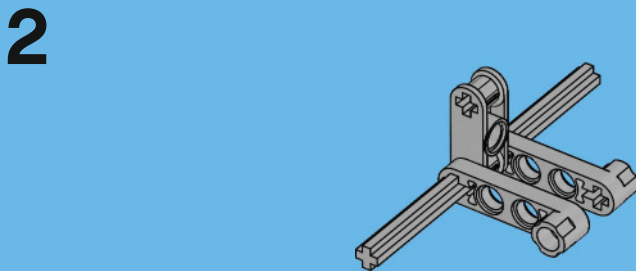
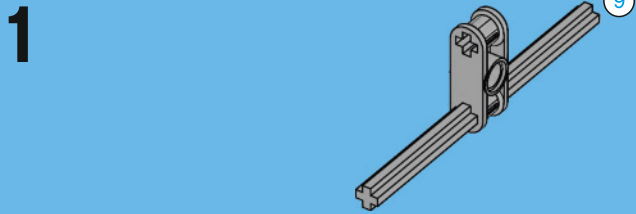
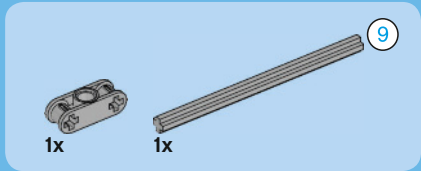
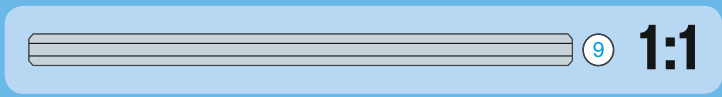
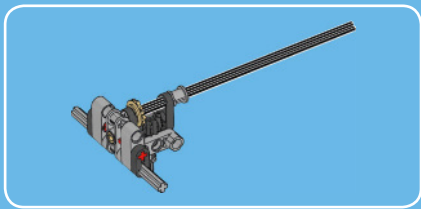

3

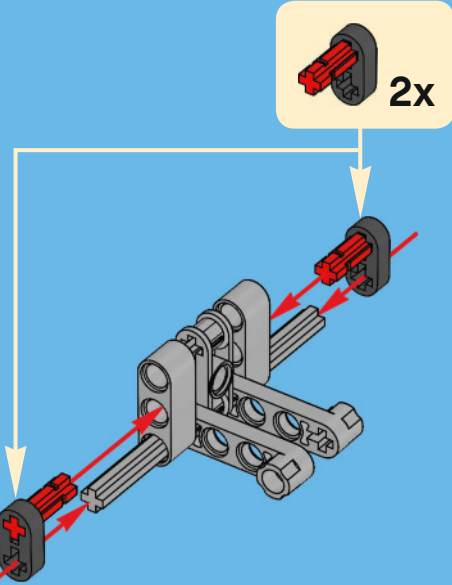

4

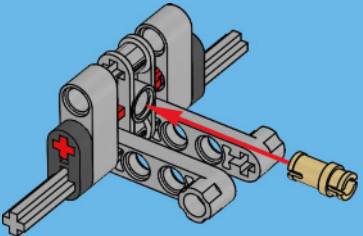

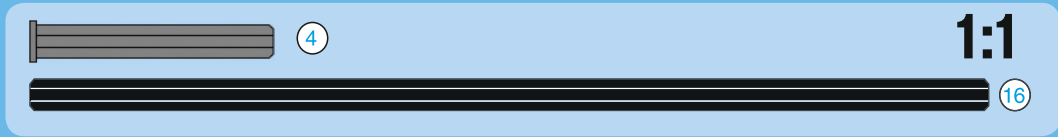
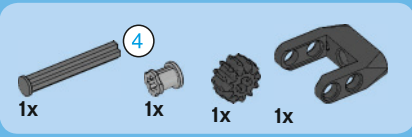

5

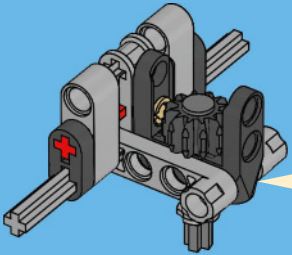
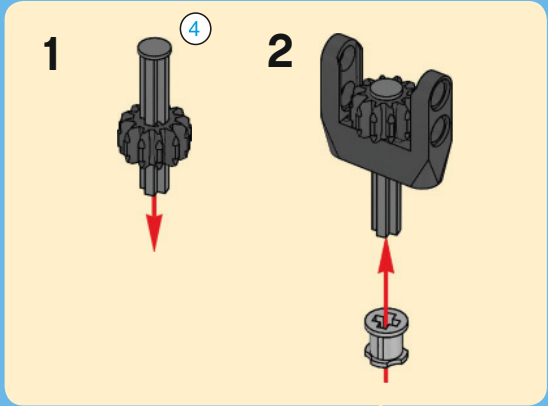

7

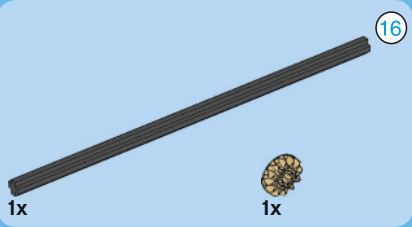
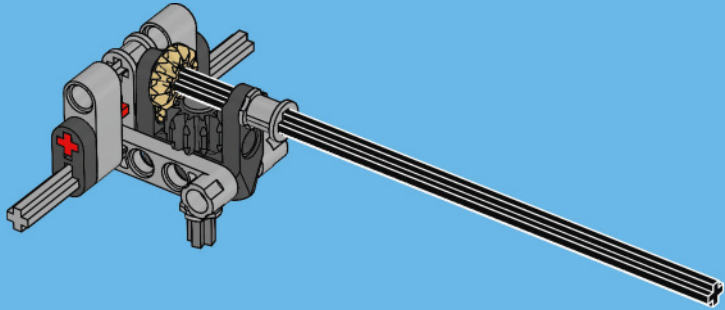

6

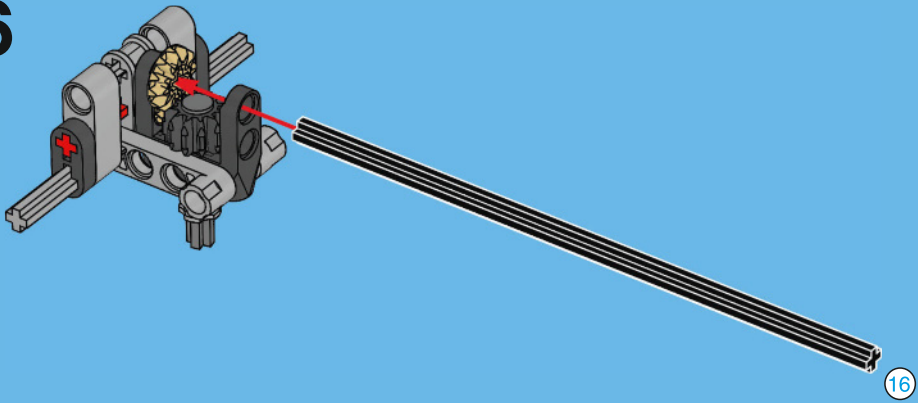

15

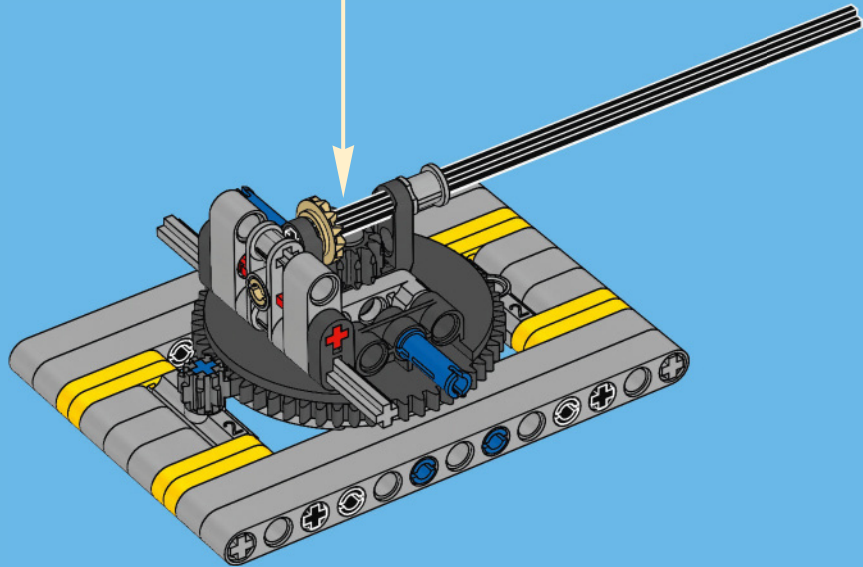



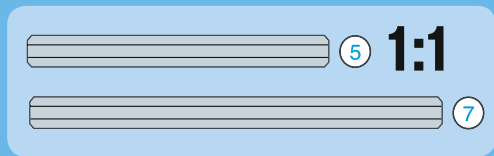
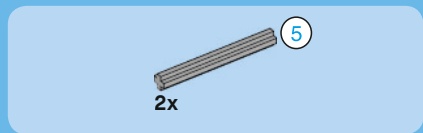

16

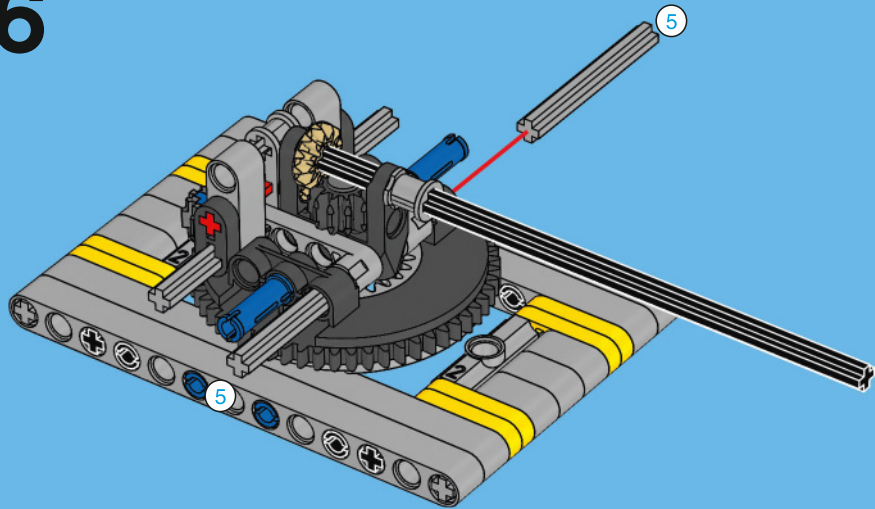

17

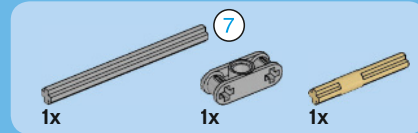
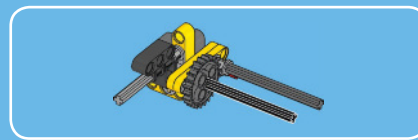
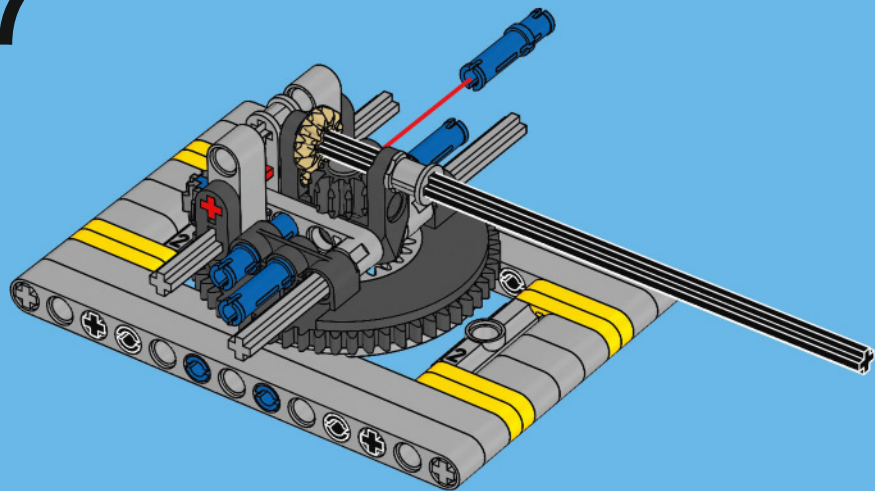

1

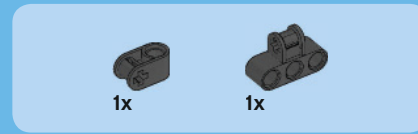
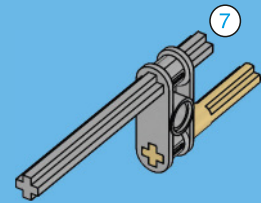

2

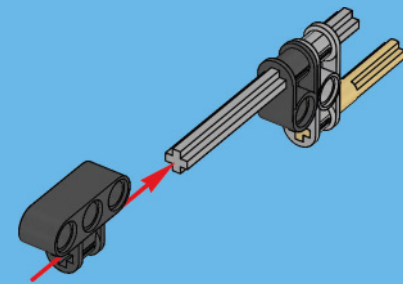

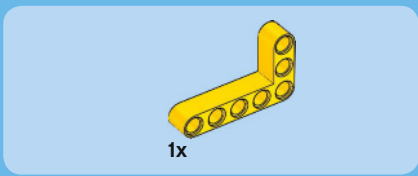

3

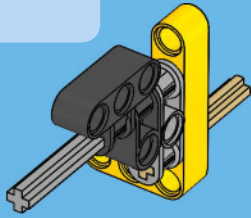

4

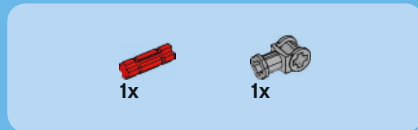
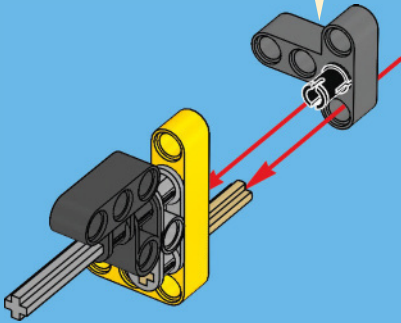
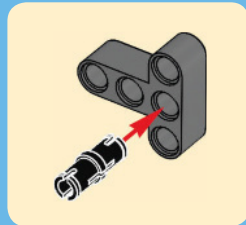

5

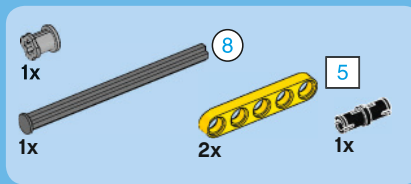
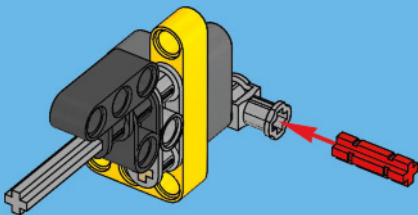

6

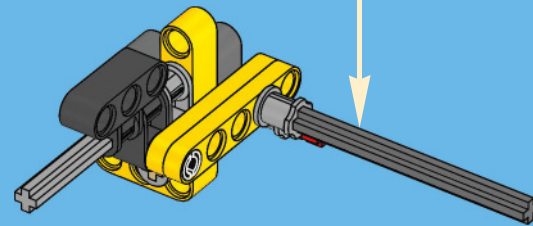
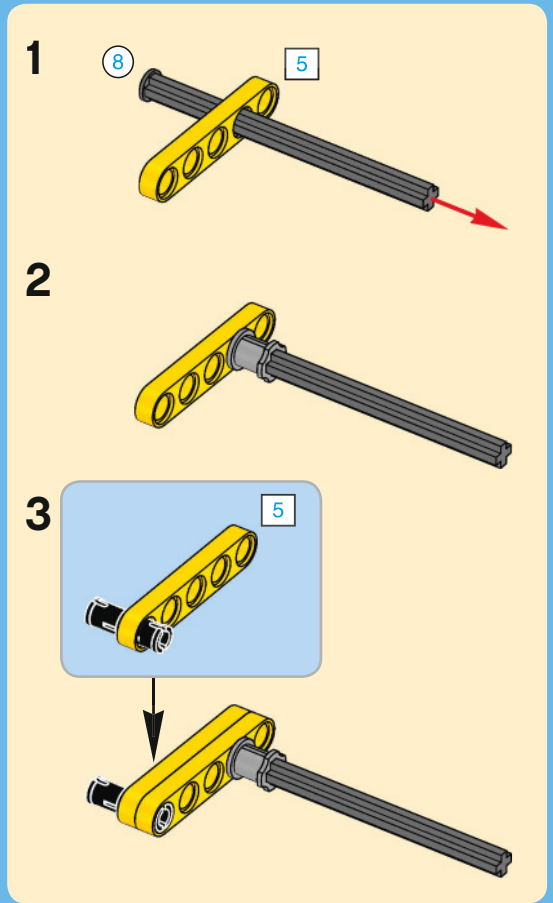
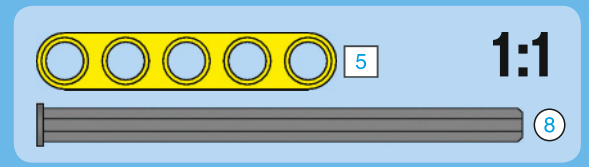



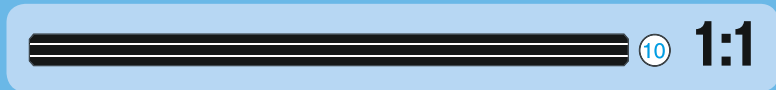
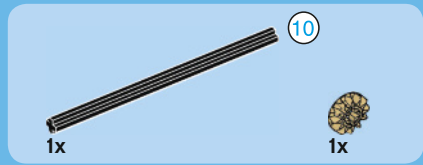

7

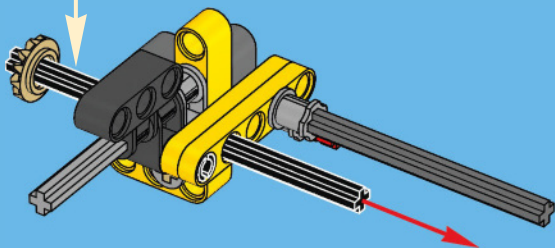
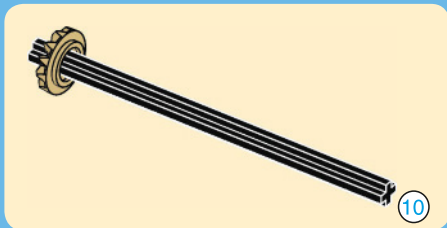

8

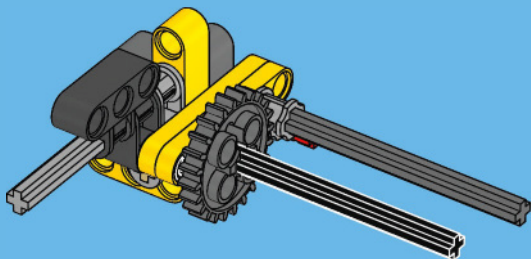

18

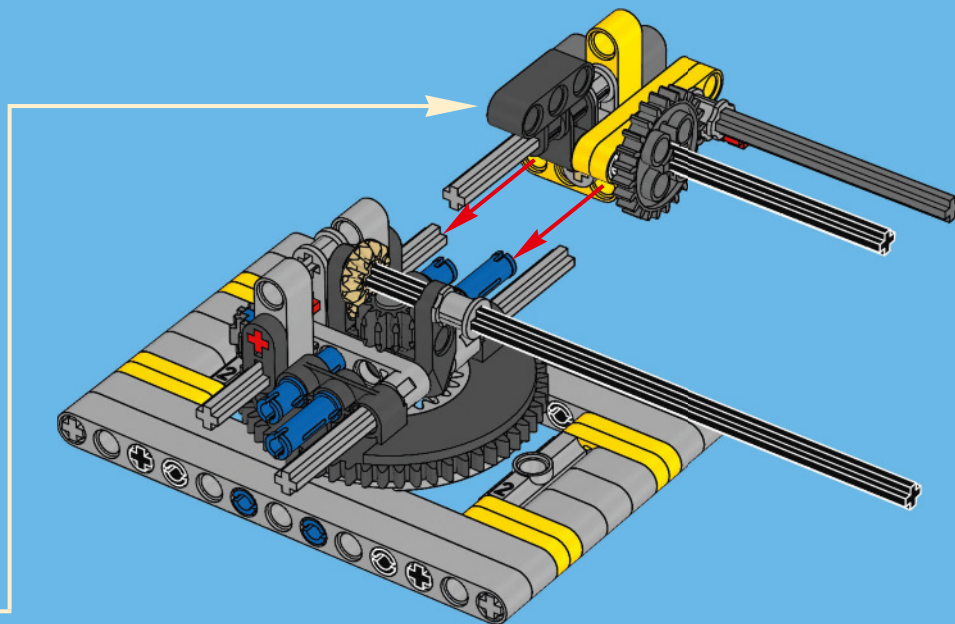



1x



1x

# 19

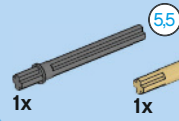
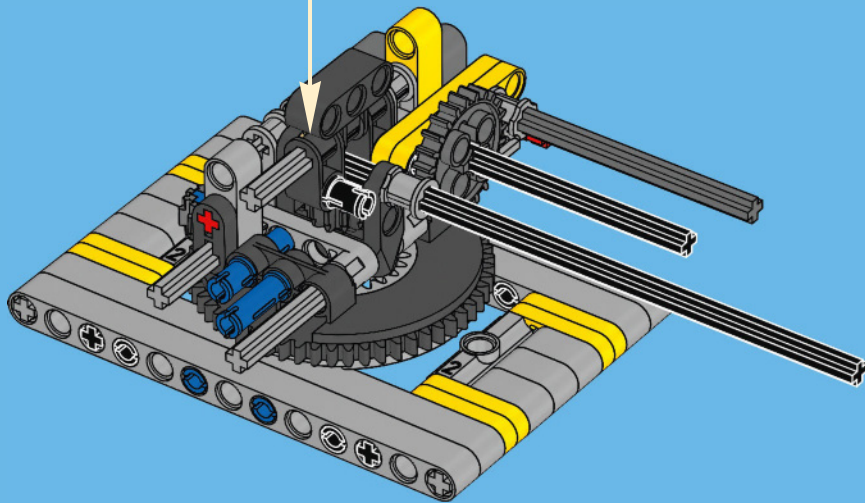
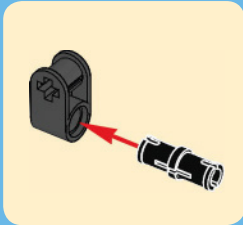

1x

1x



1x



1x

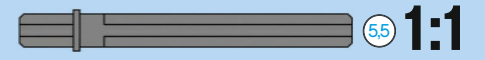

5.5

1:1

# 20

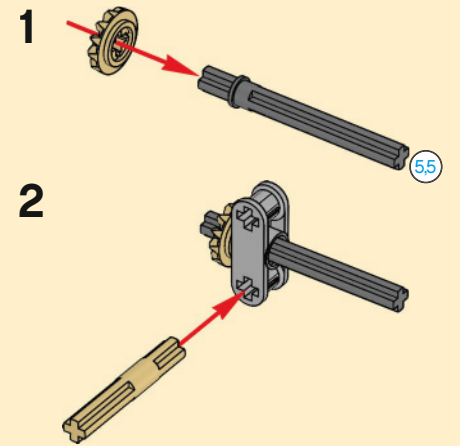

1

5.5

2

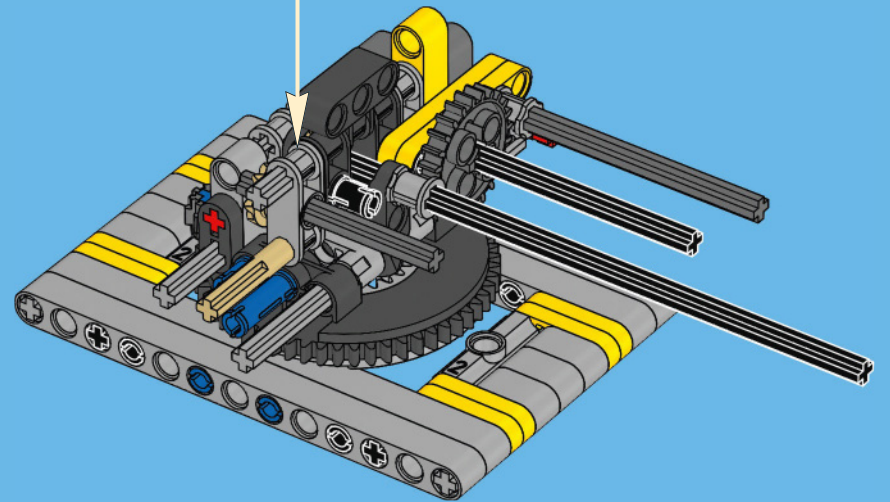



1x

1x

# 21

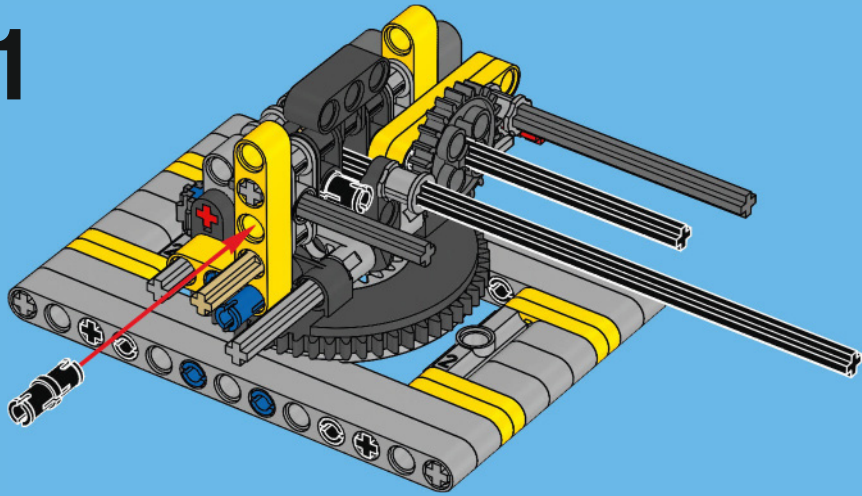

1x

1x

1x

# 22

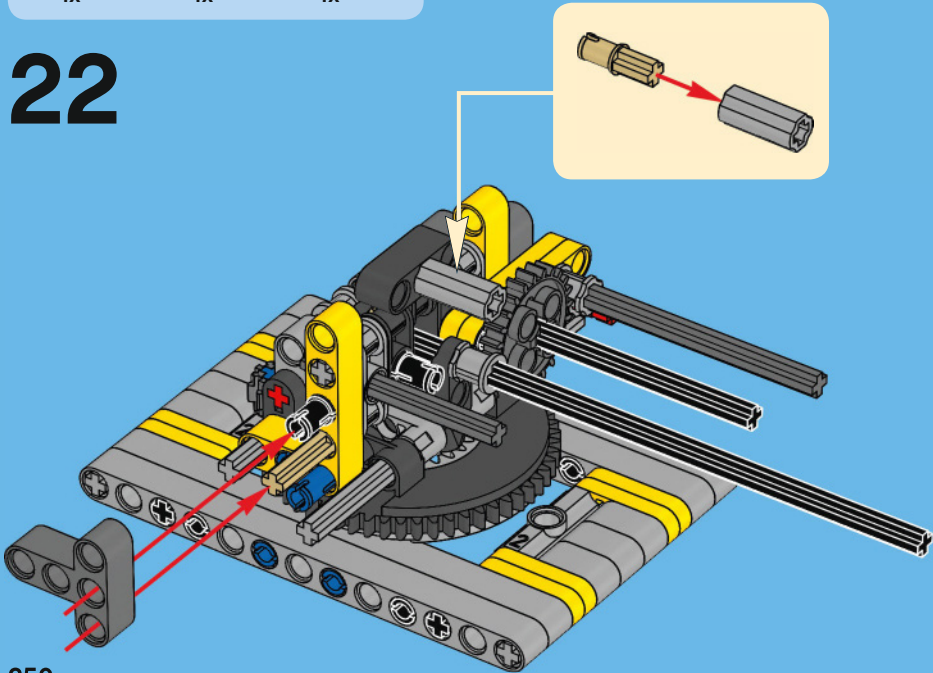

250

1x

1x

# 23

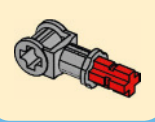
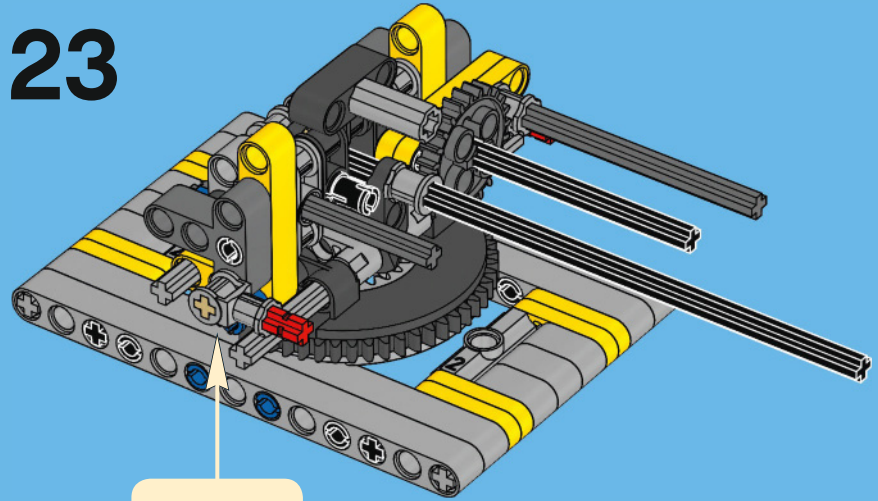

1x

5

1x

1x

5

1:1

# 24

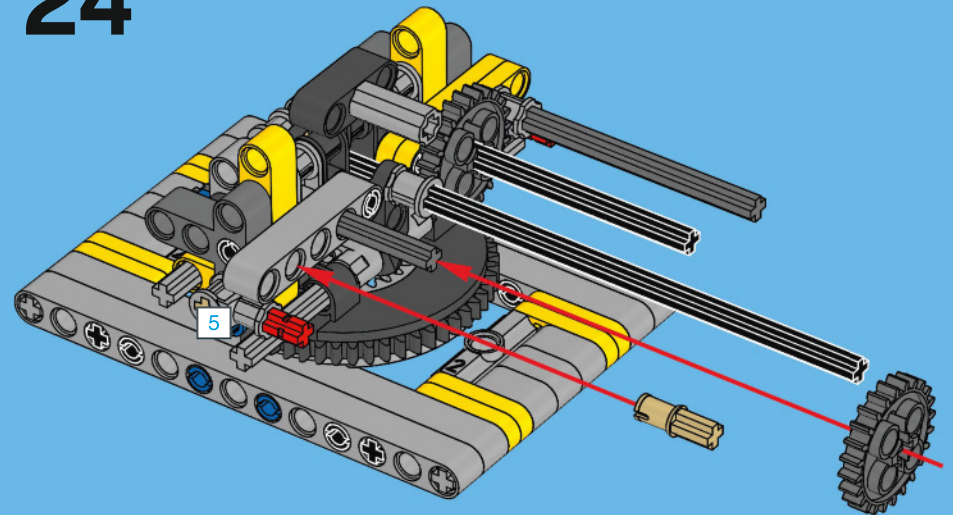

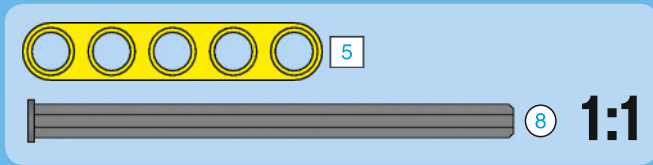
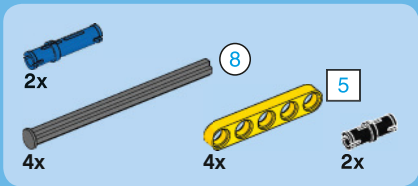

25

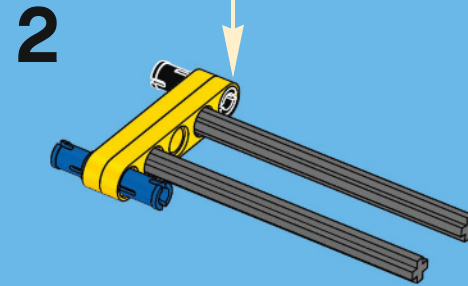
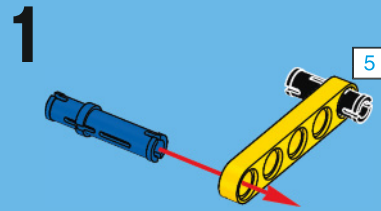
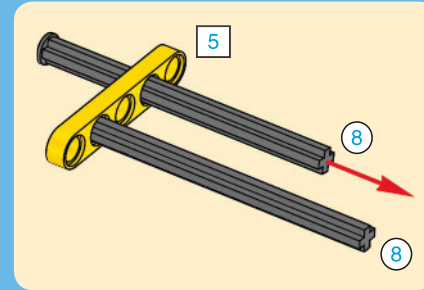

2x

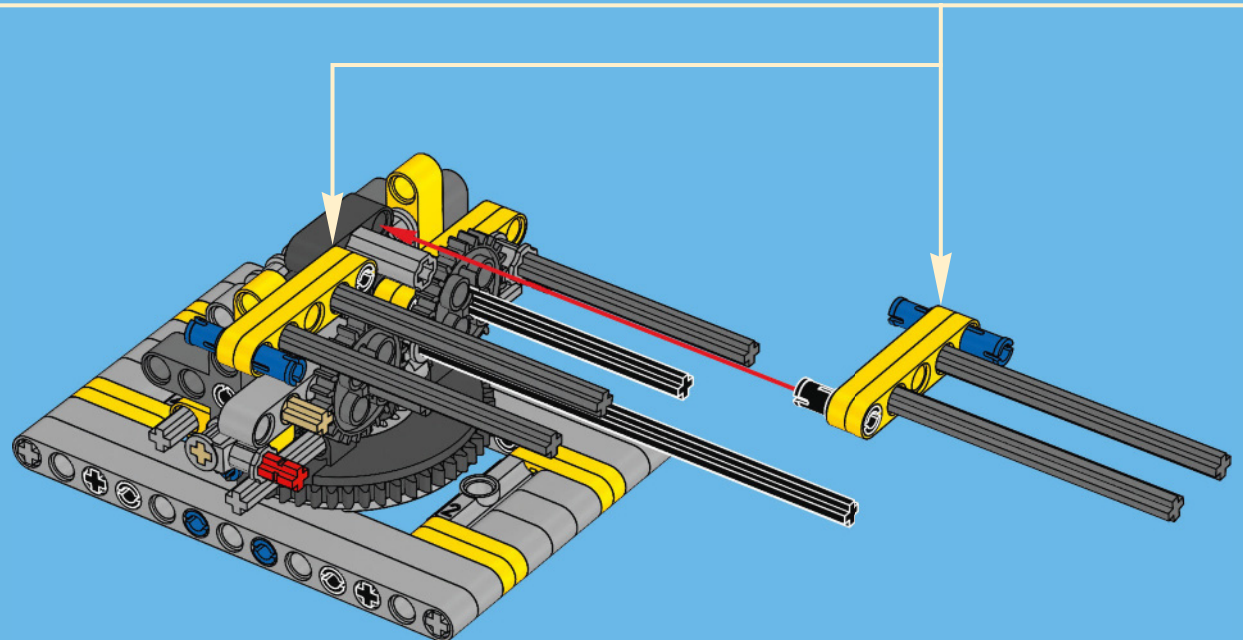



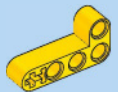

2x

# 26

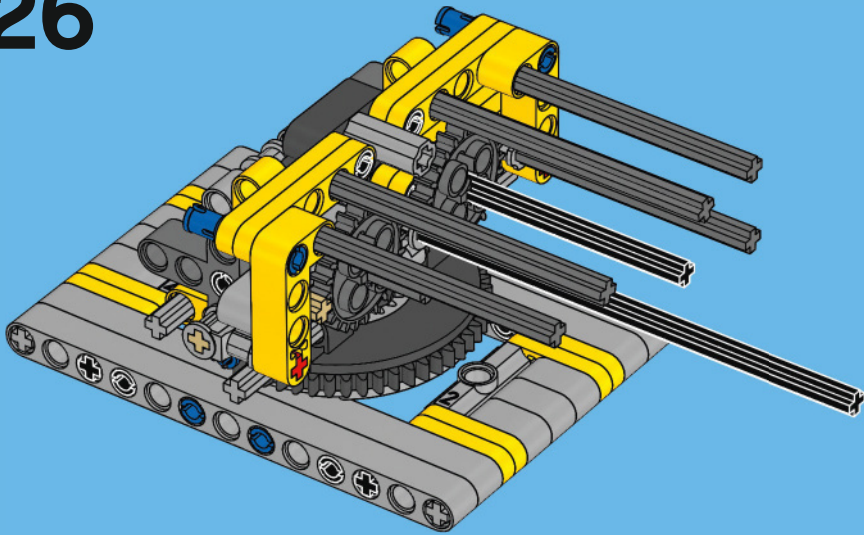

2x

# 27

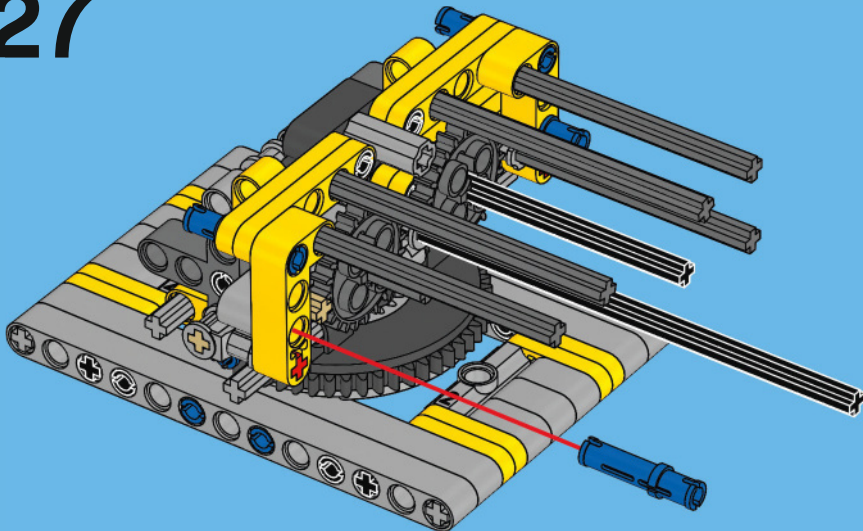

2x

# 28

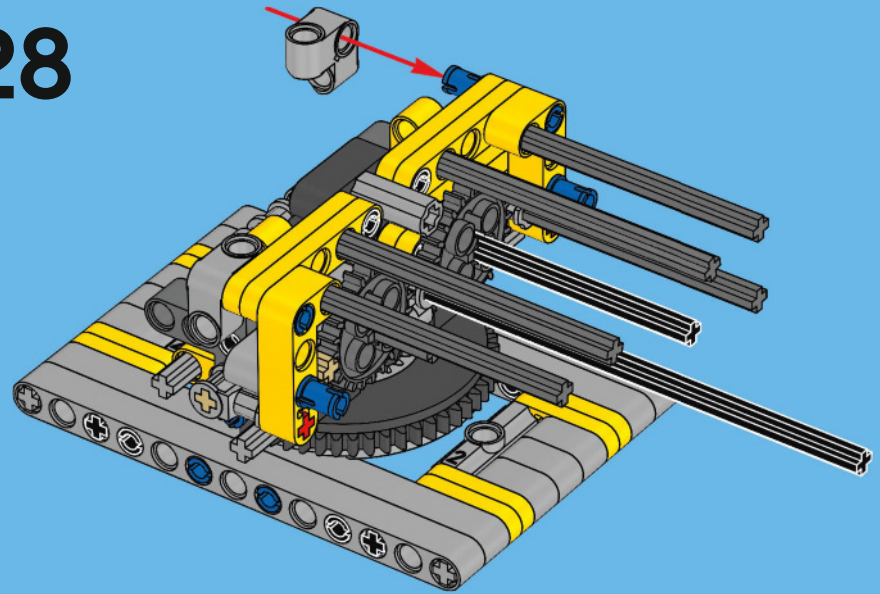

2x



2x

# 29

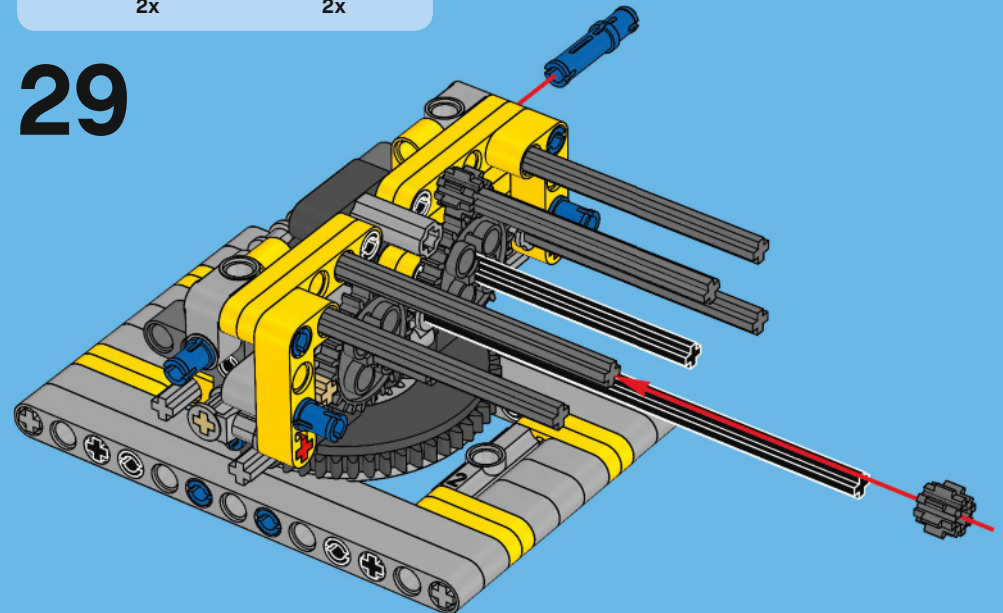

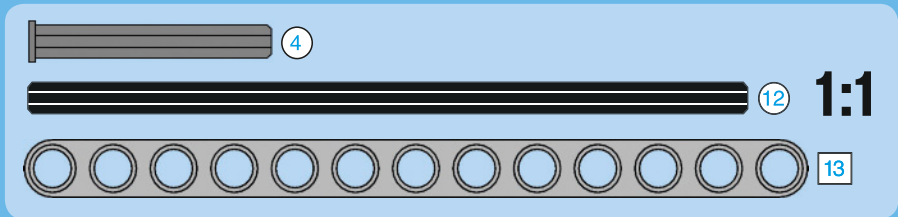
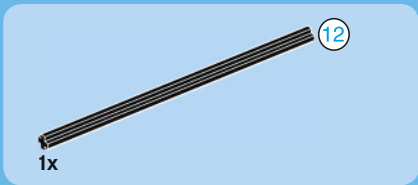

30

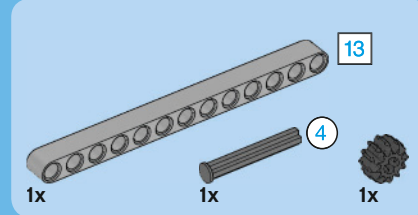
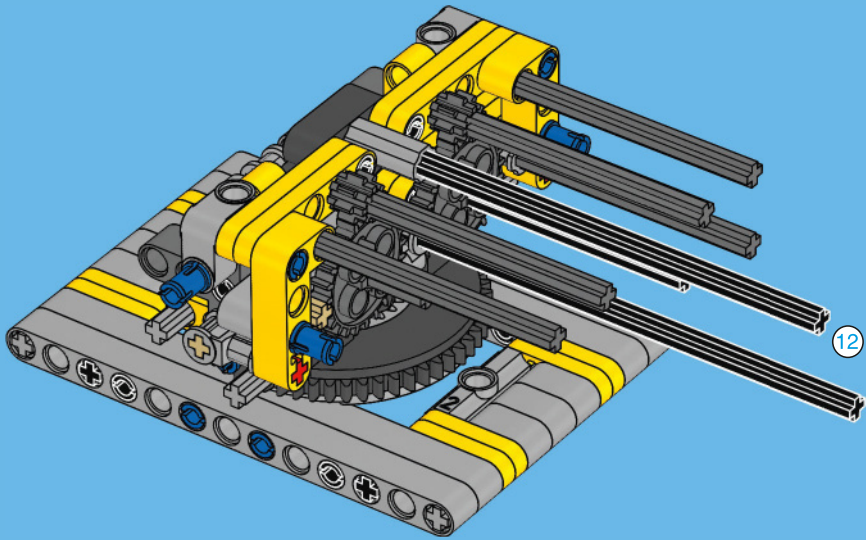

31

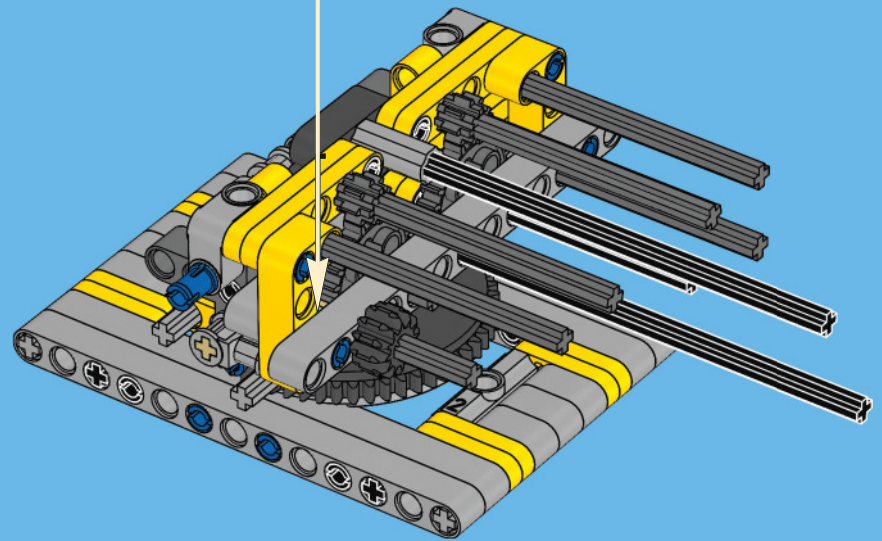
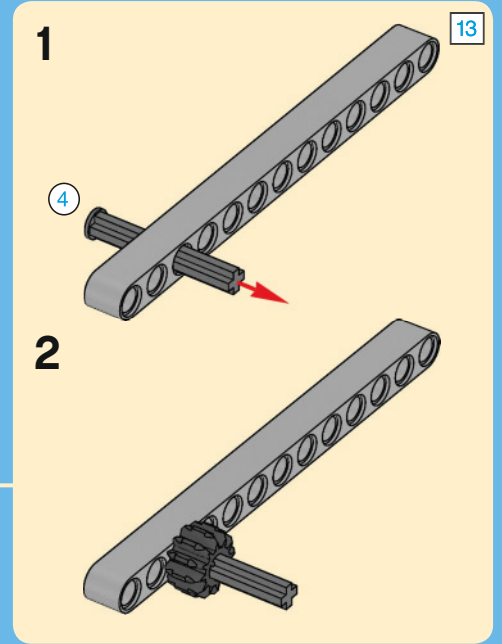





2x

# 32

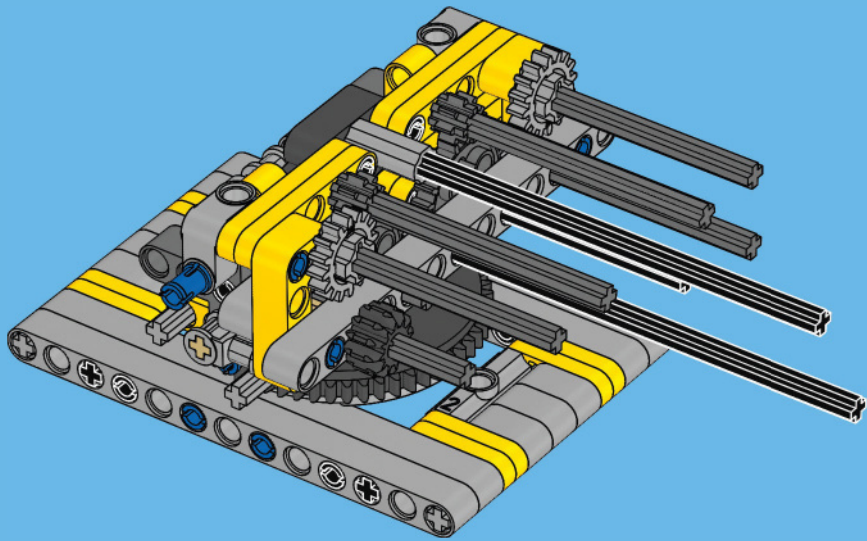

3x

# 33

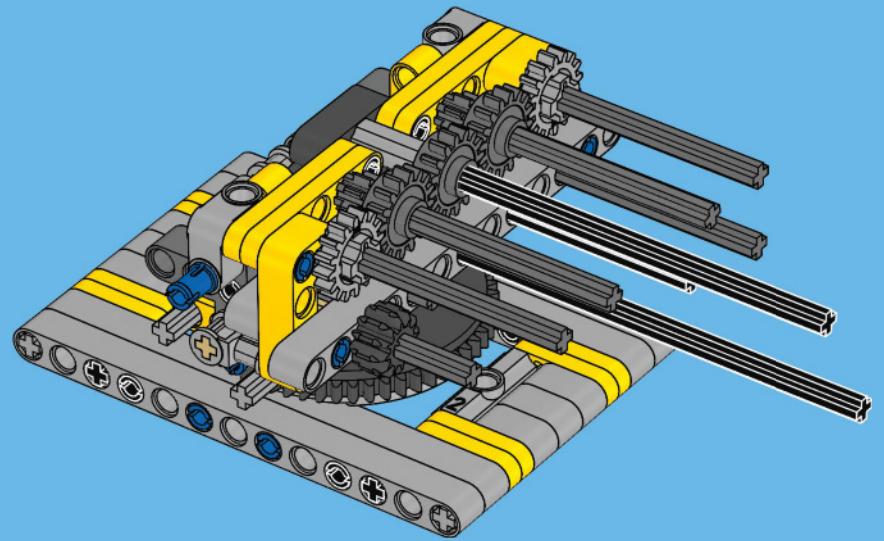

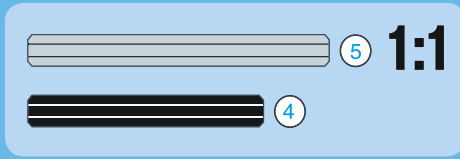
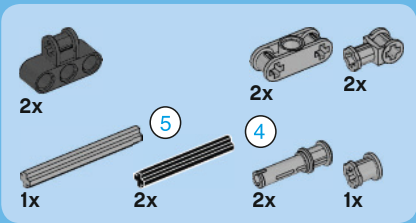

# 34

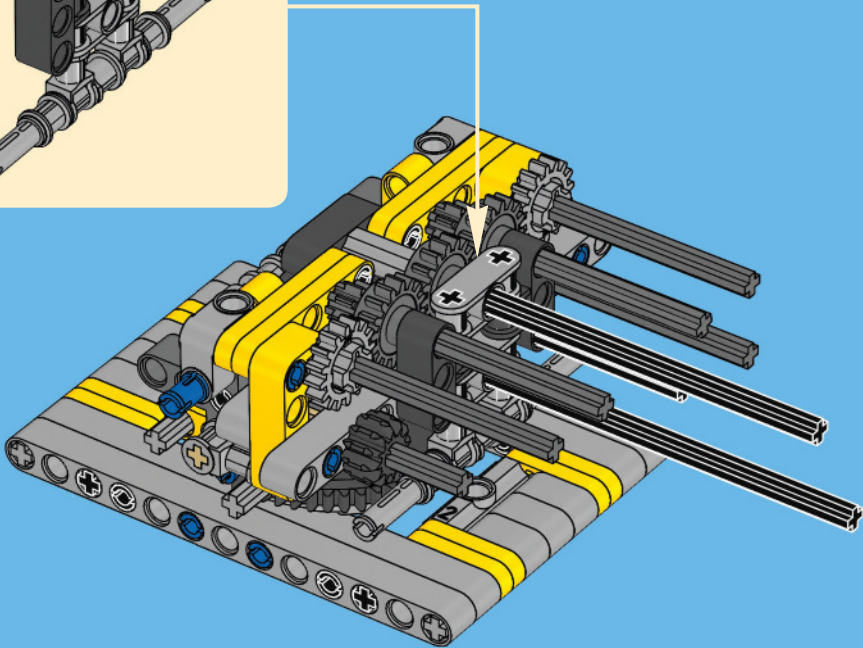
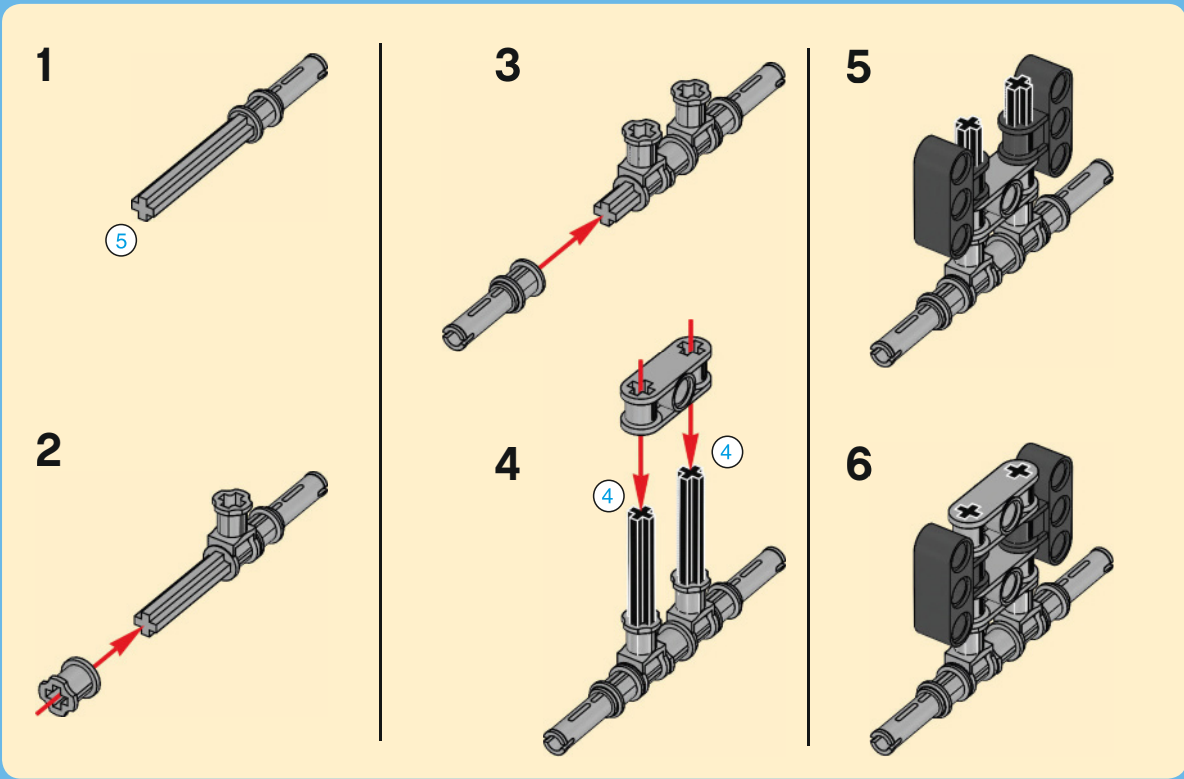



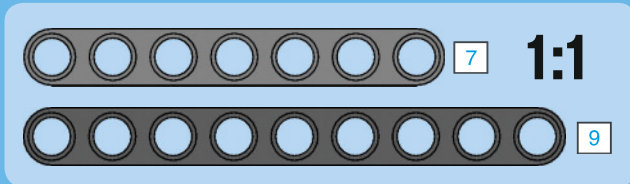
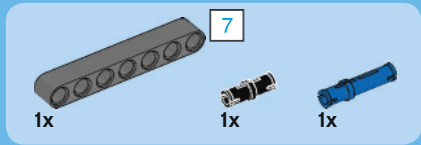

# 35

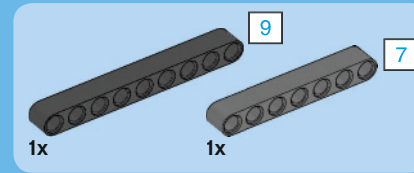
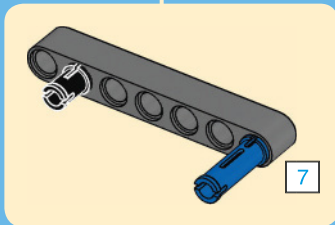
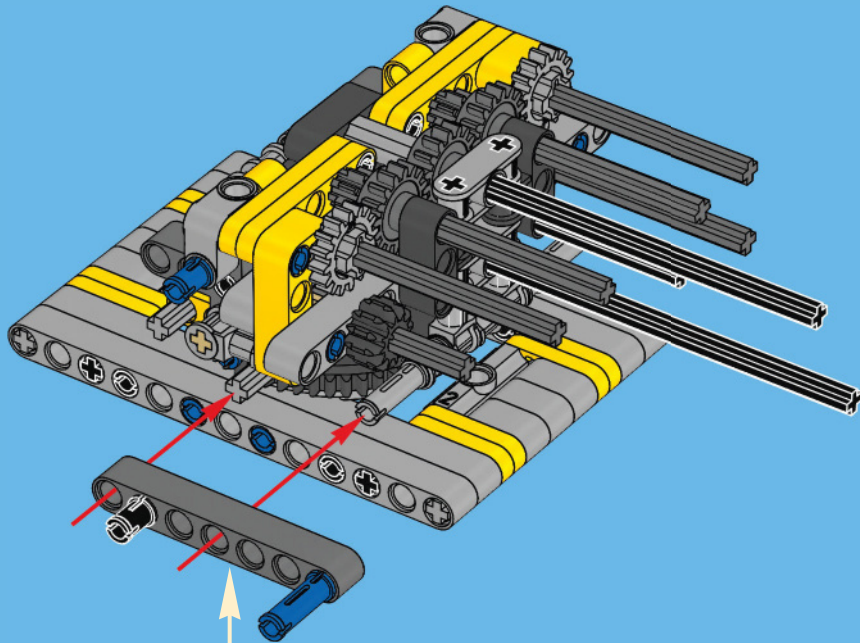

# 36

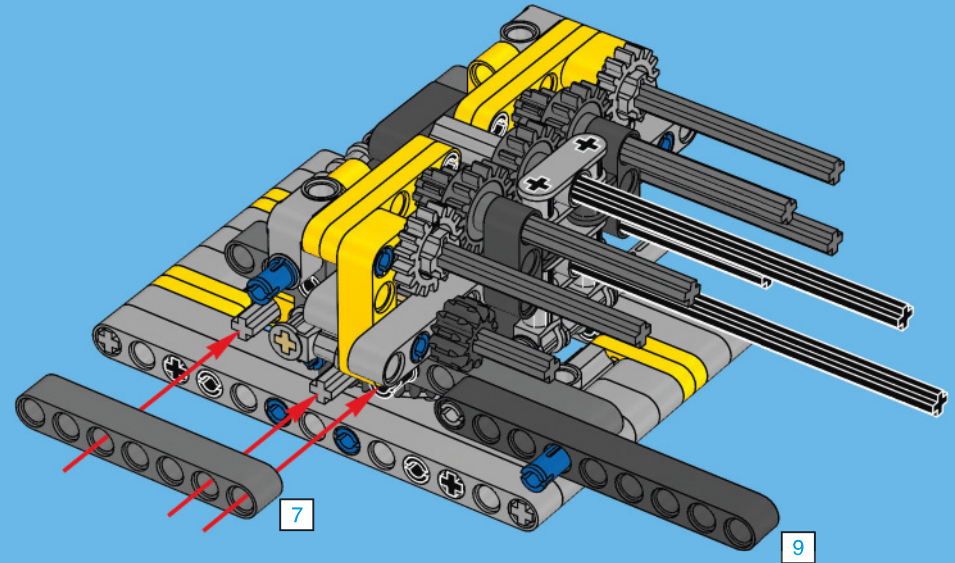

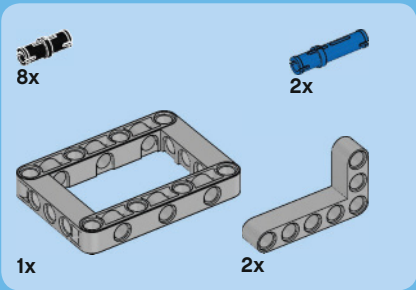

37

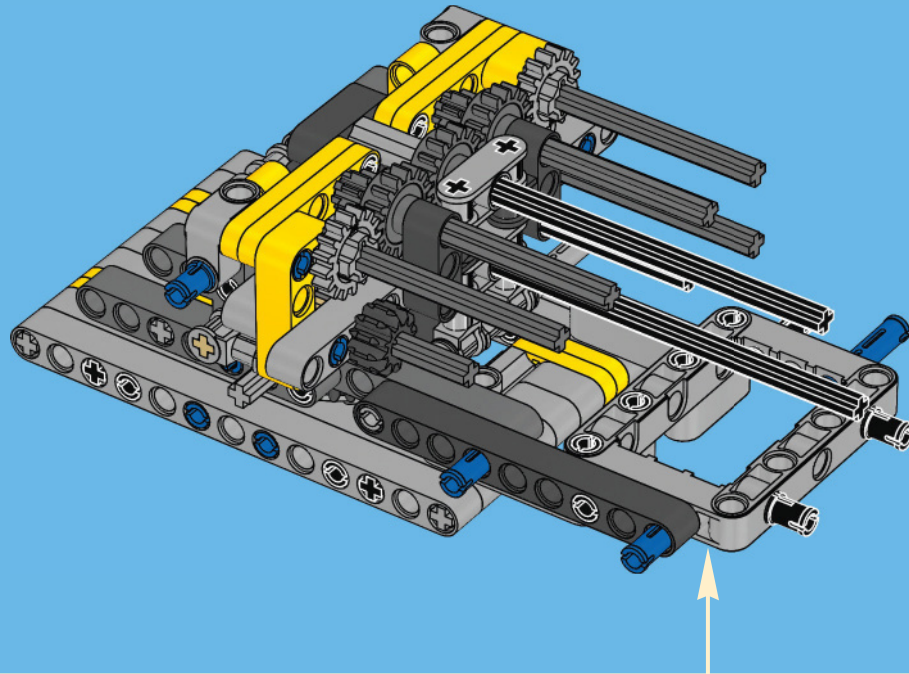

1

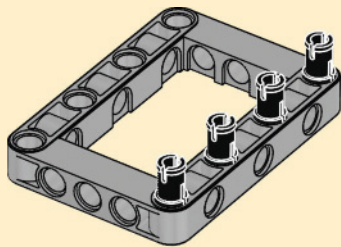

2

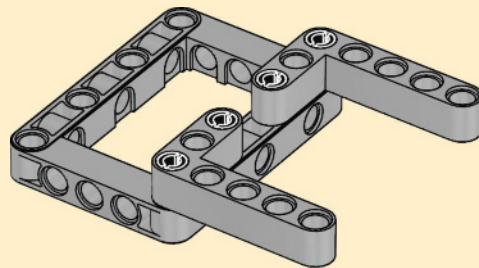

3

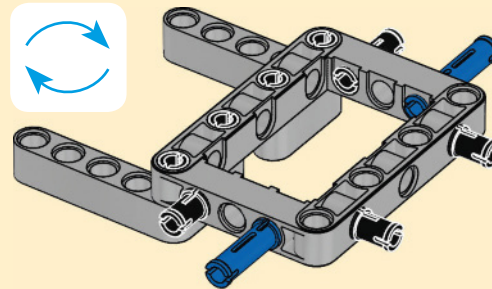



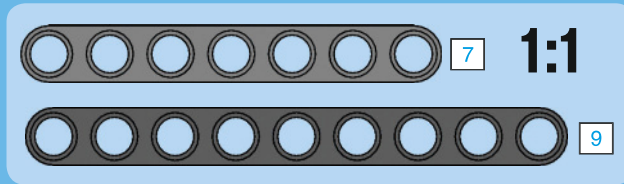
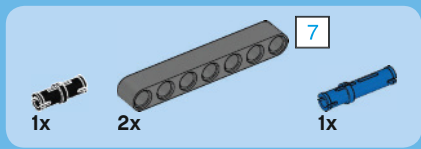

# 38

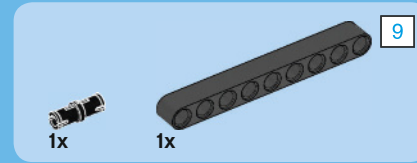
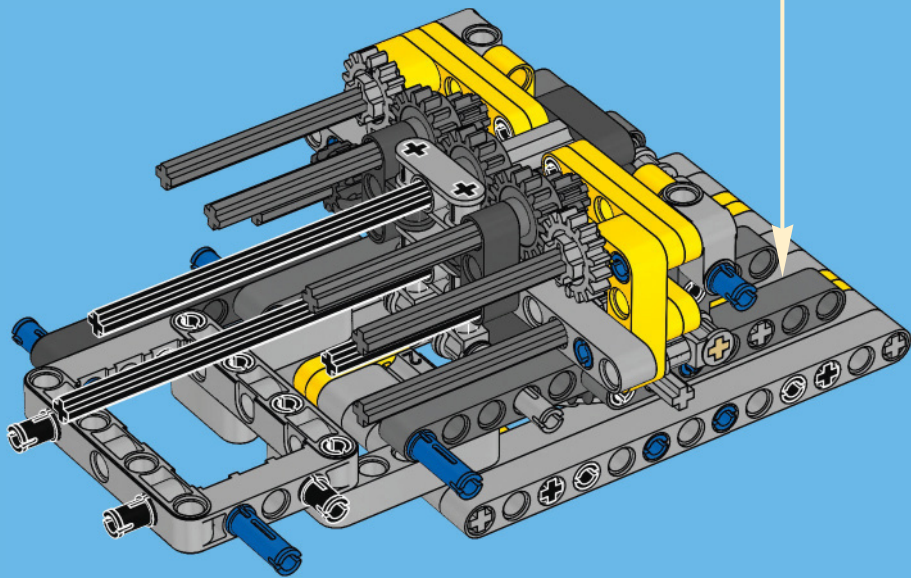
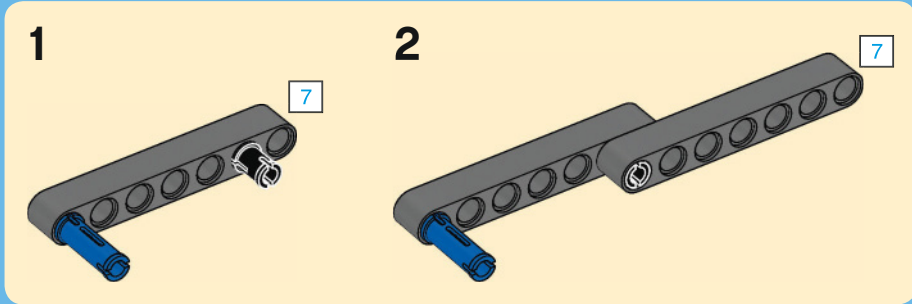

# 39

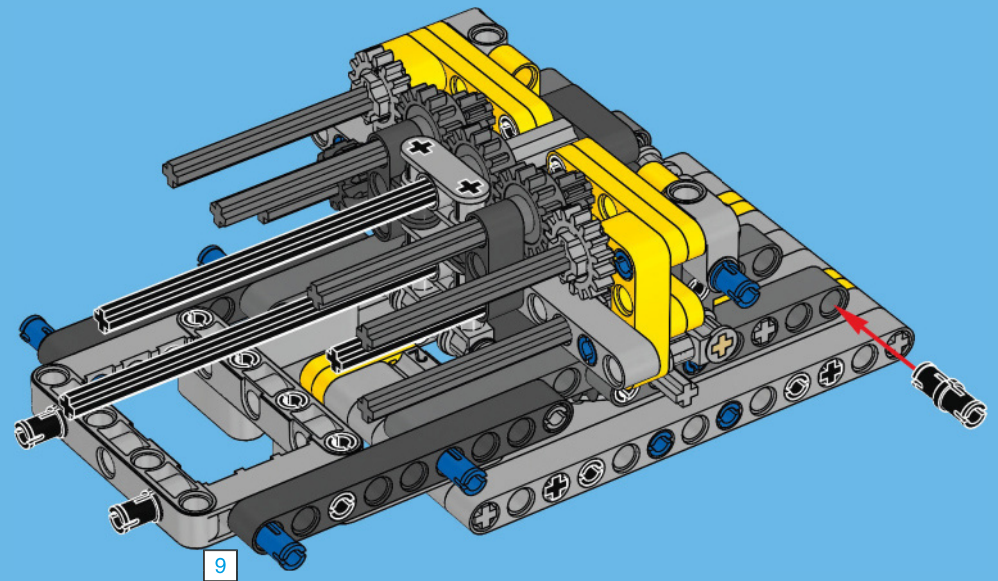



2x



1x

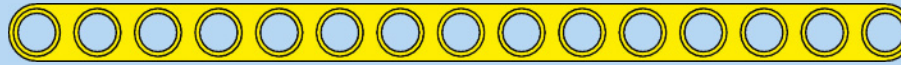

15

1:1

# 40

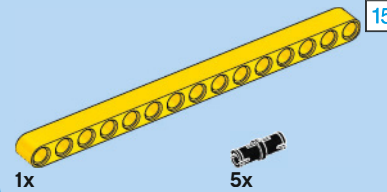
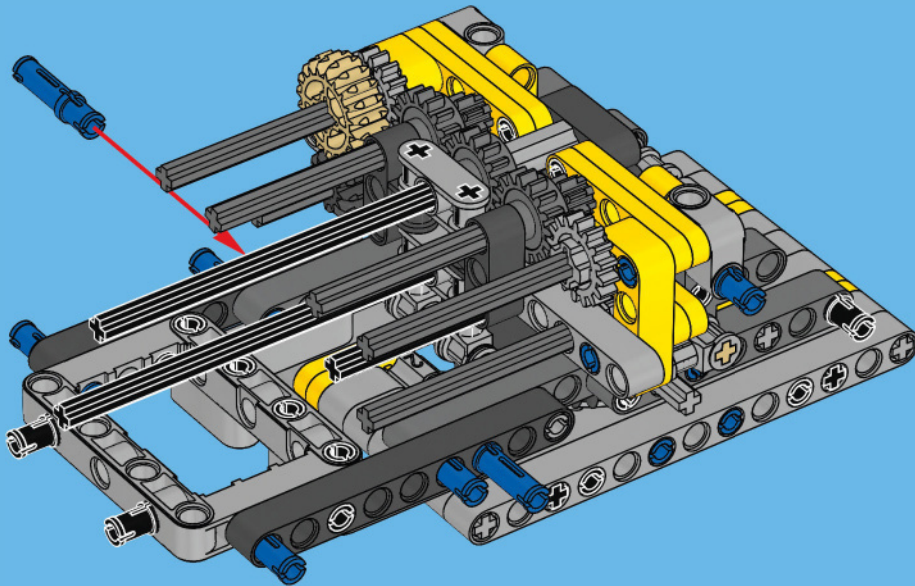

1x

5x

# 41

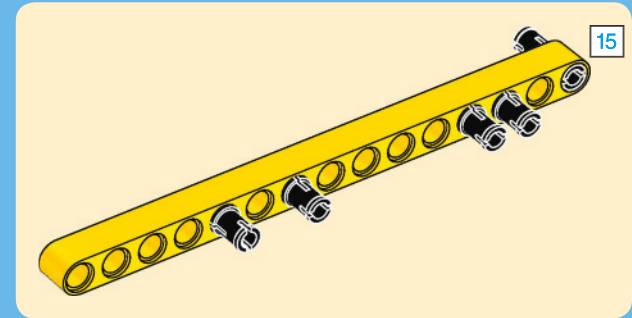

15

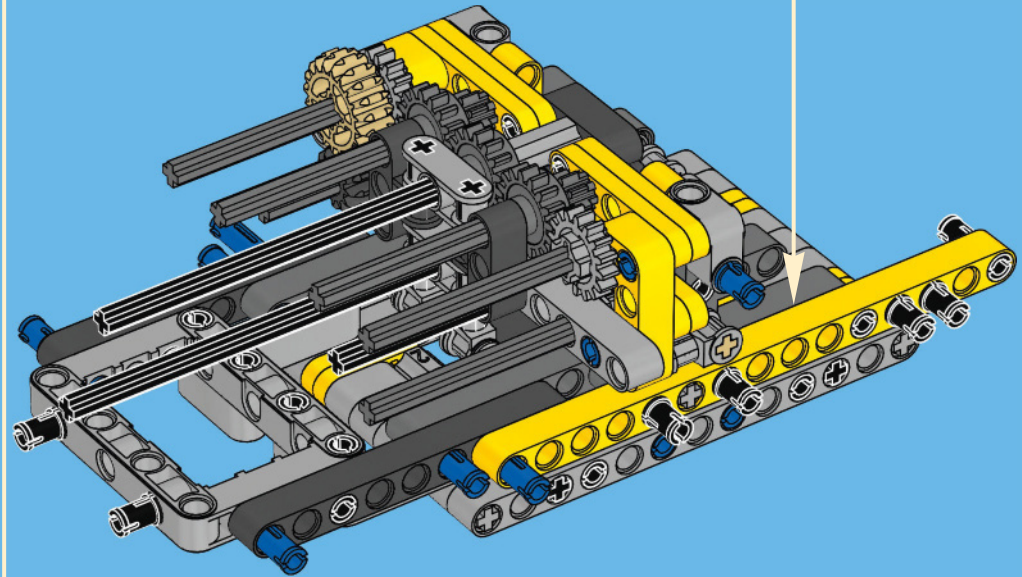



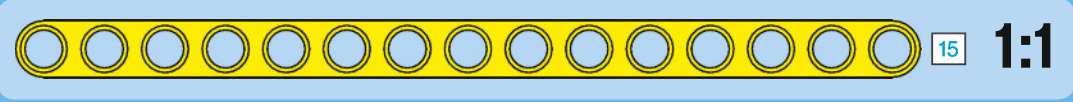
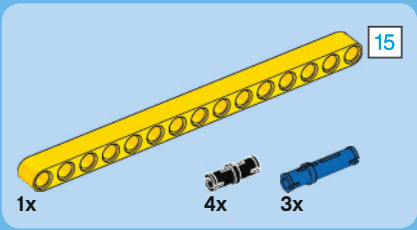

42

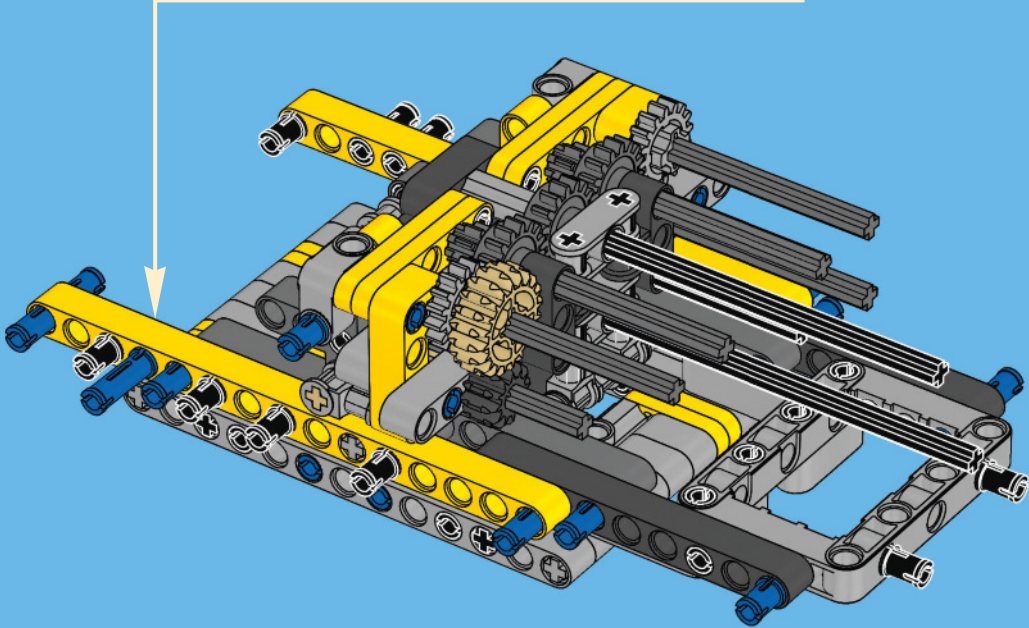
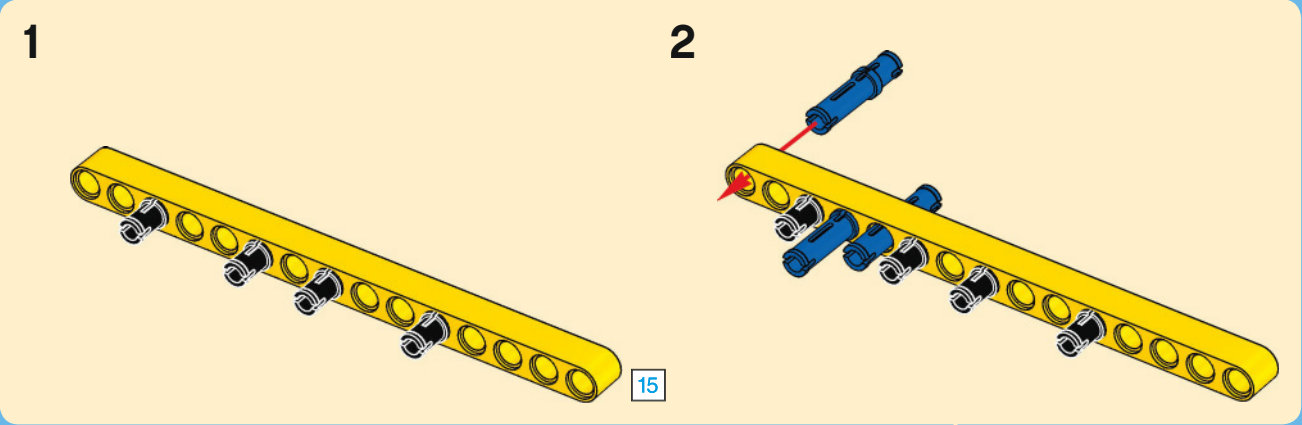



2x



2x

# 43

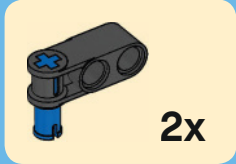

2x

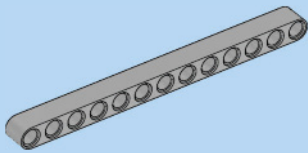
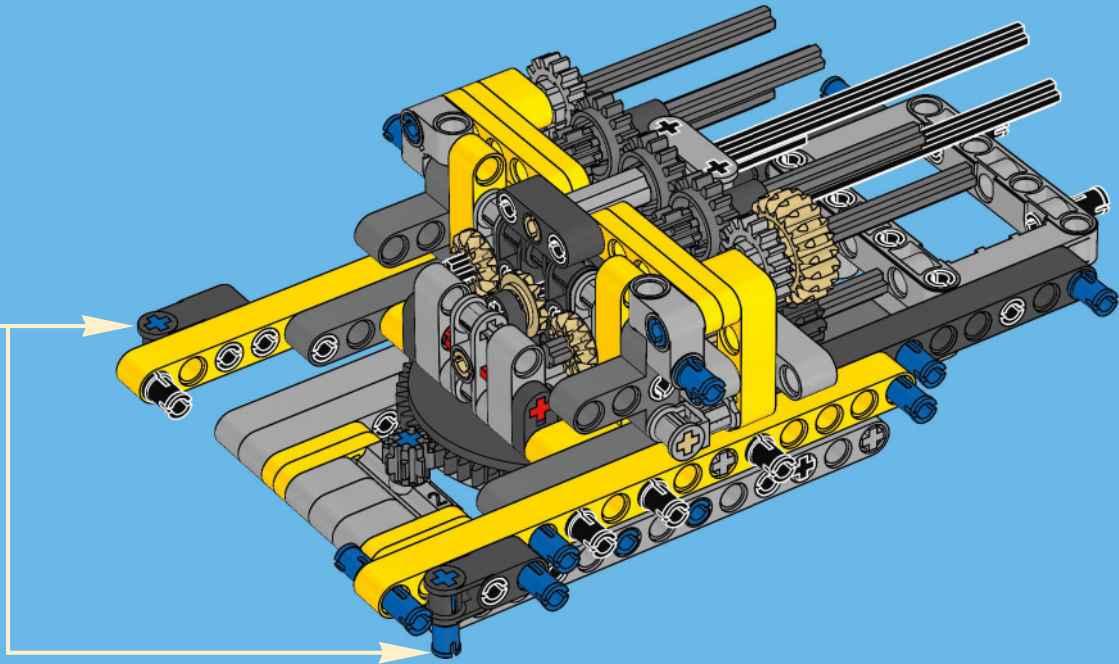

1x

13

# 44

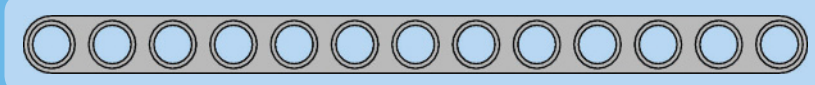
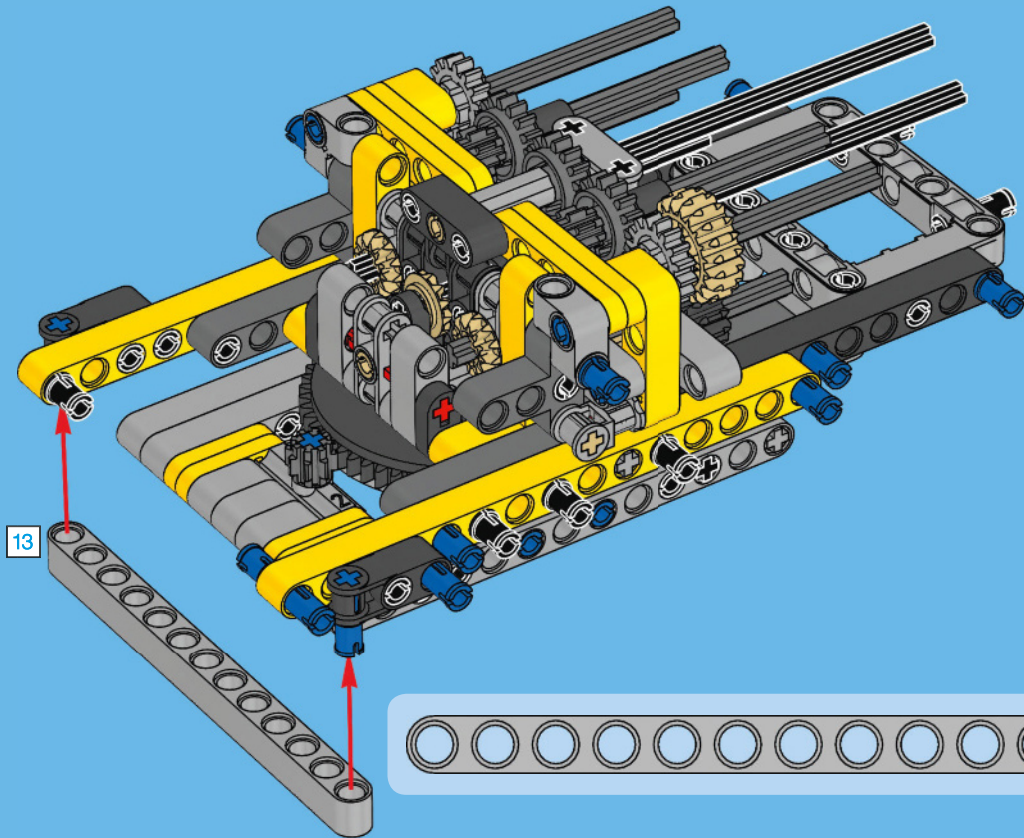

13

1:1



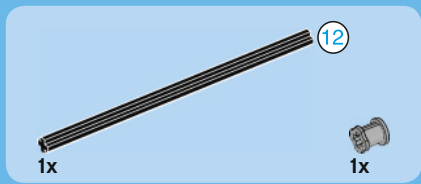

45

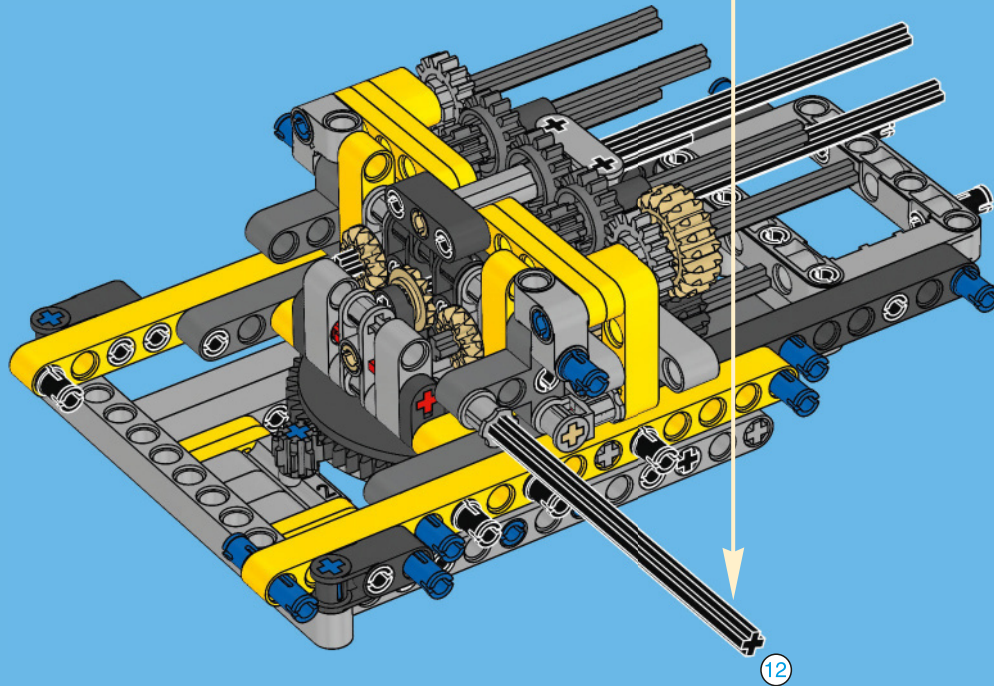

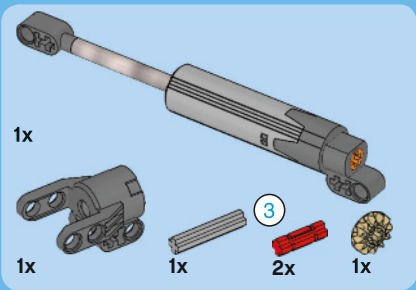

# 46

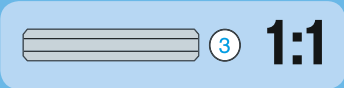
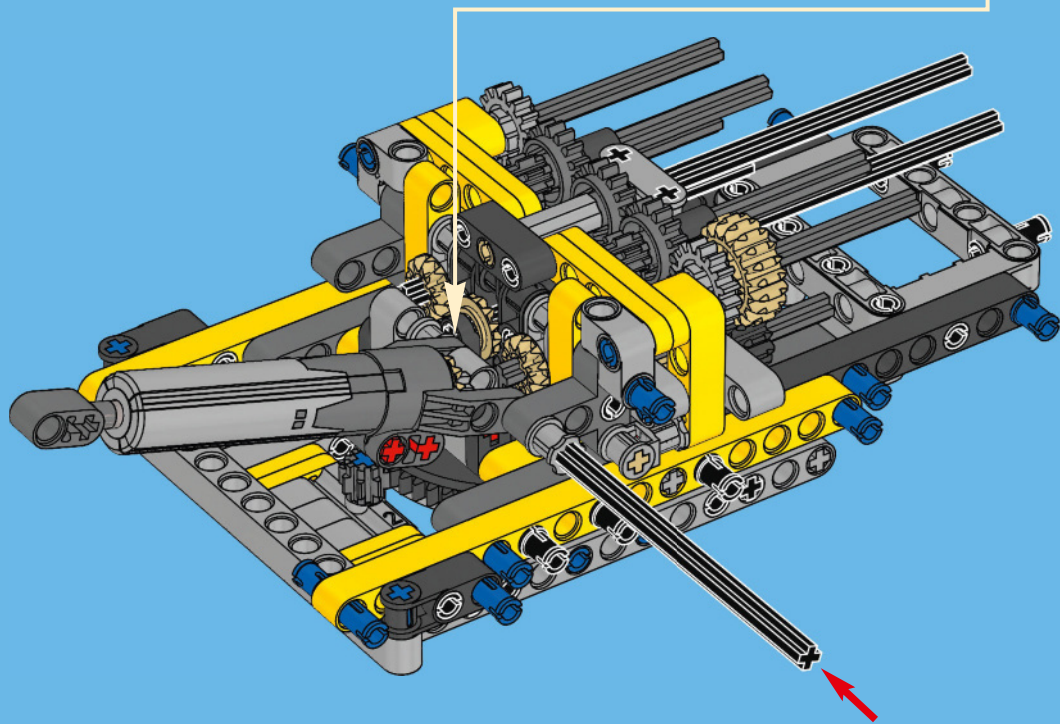
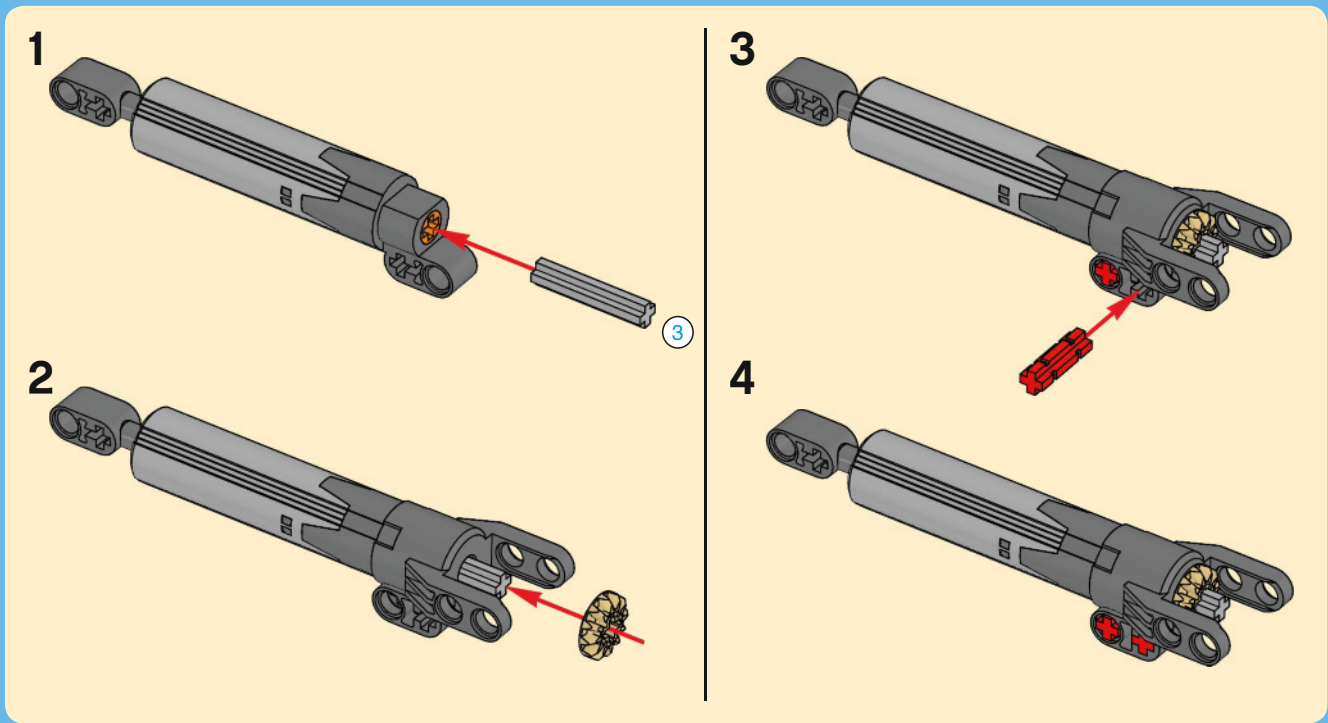





1x

# 47

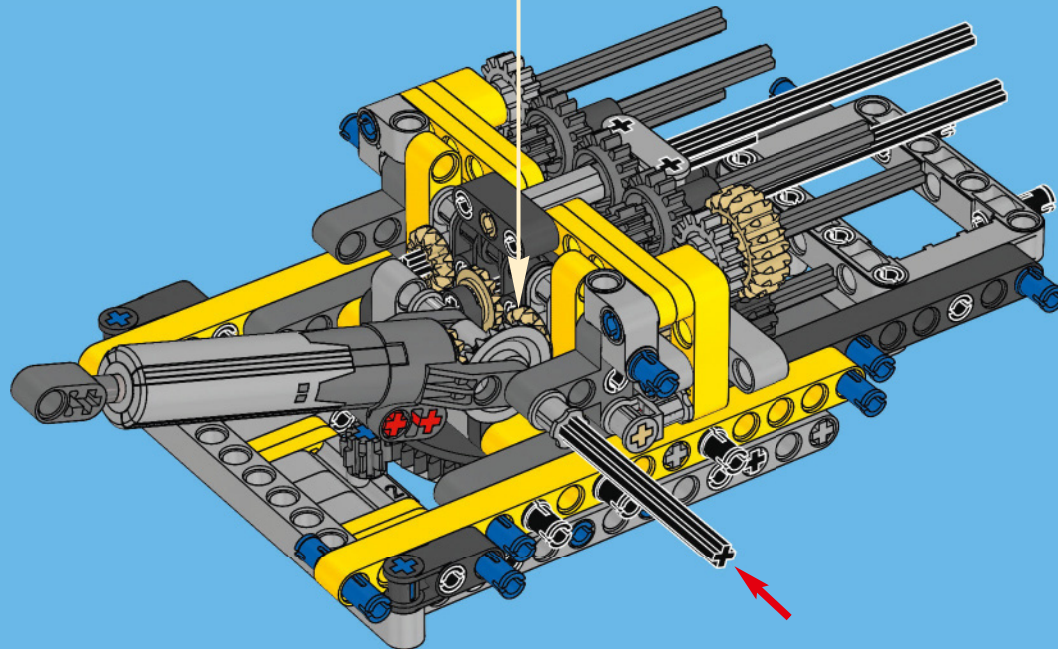
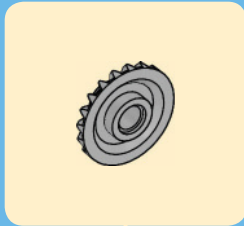

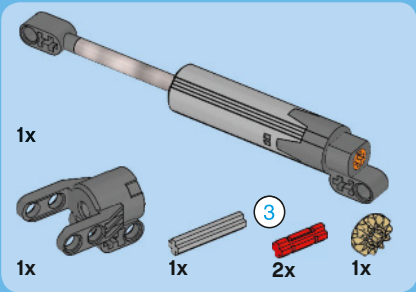

48

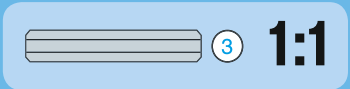
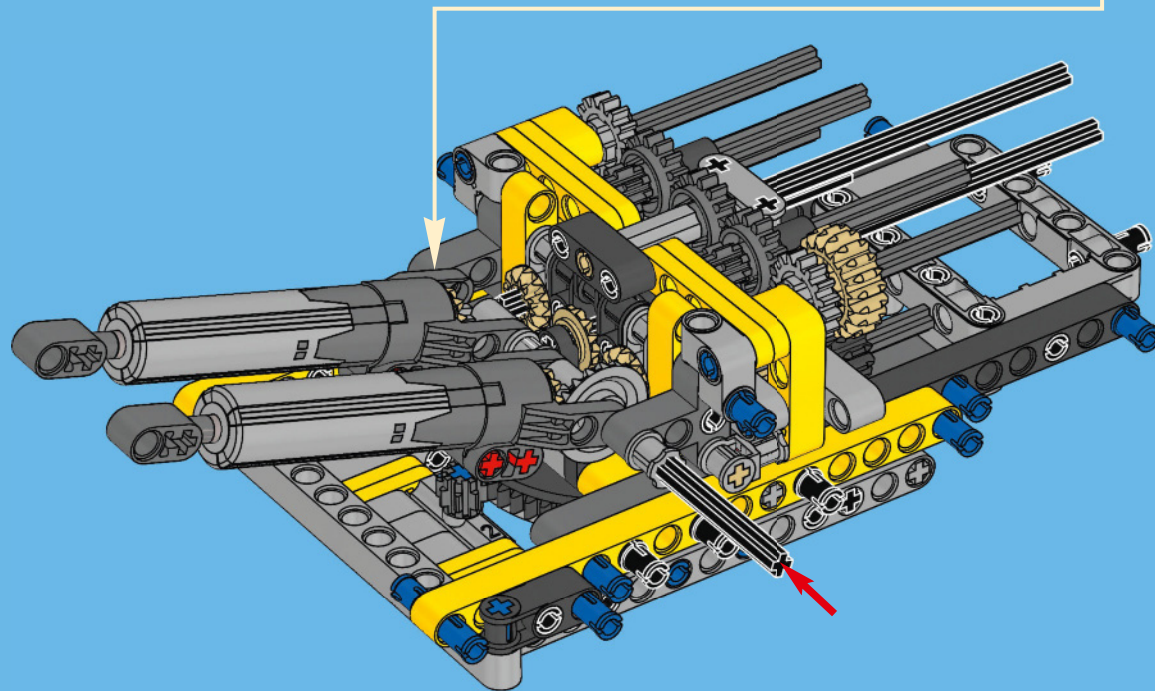
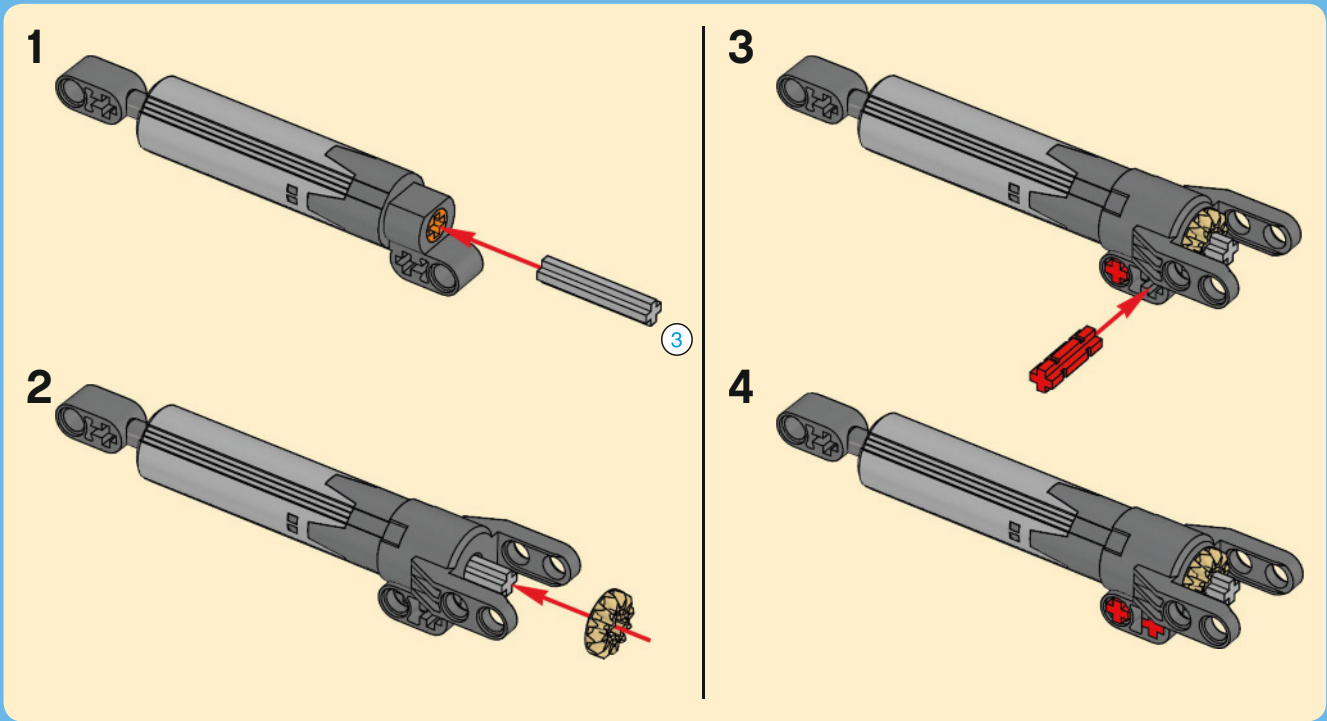





1x

# 49

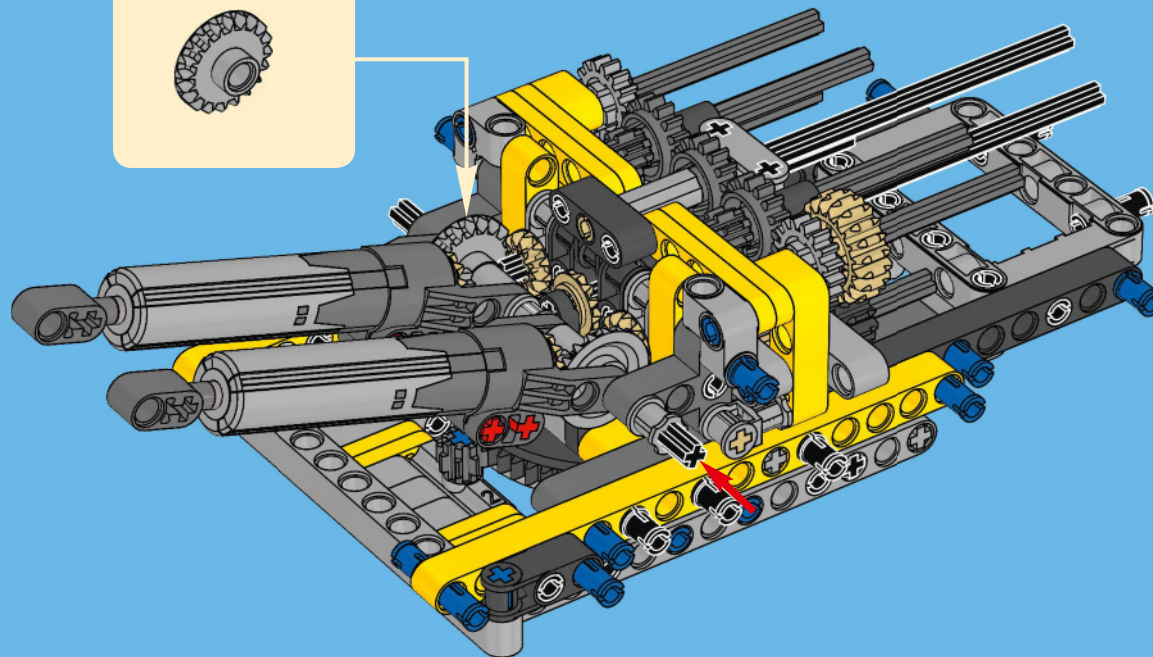
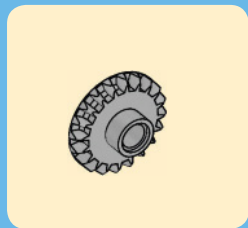

1x

# 50

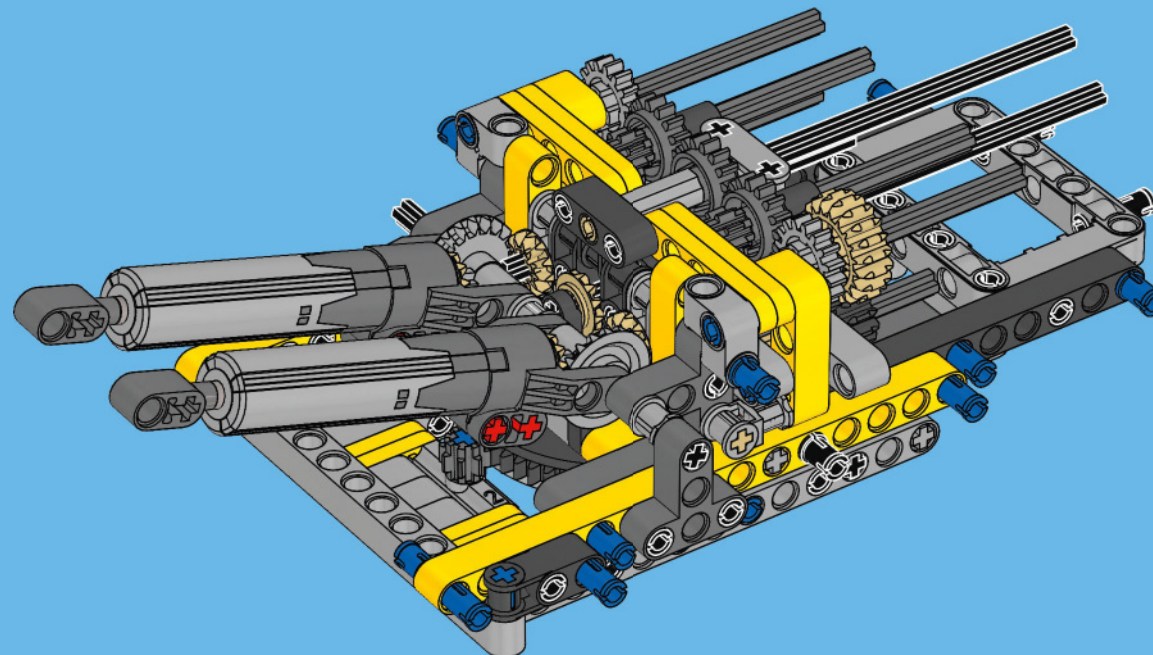



3x

# 51

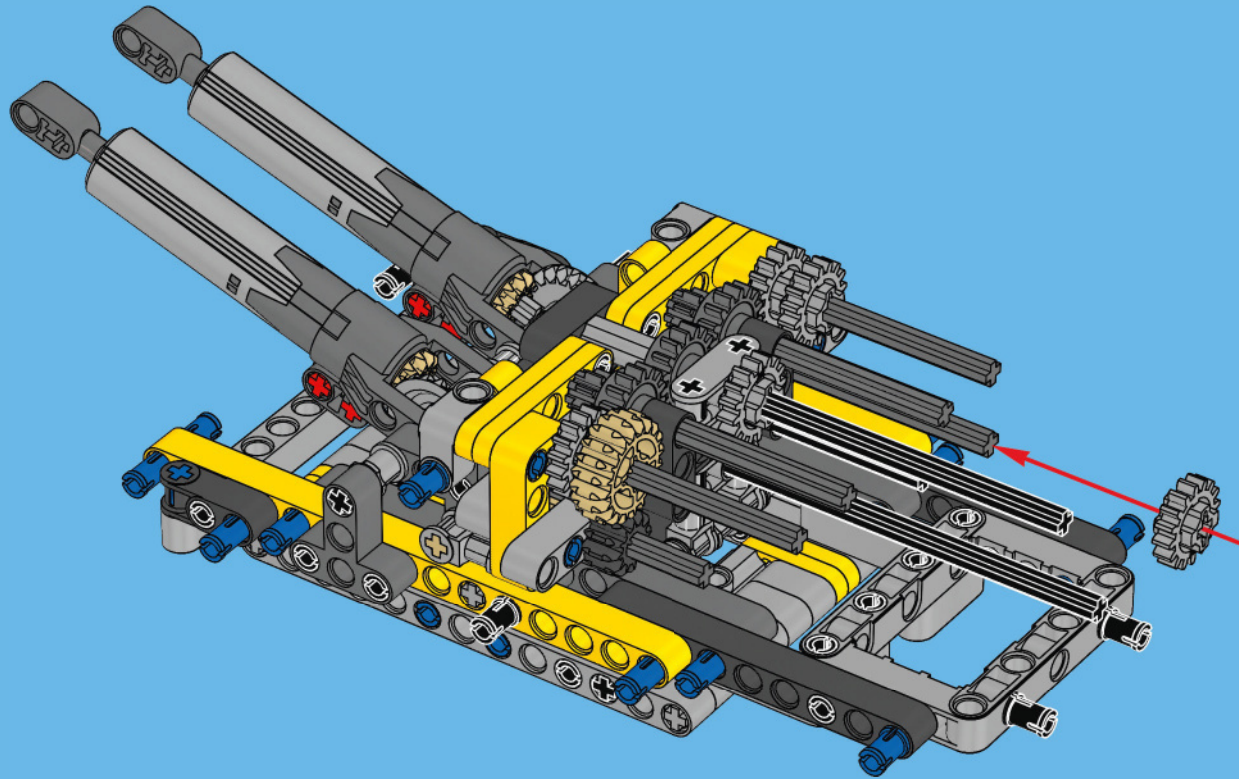





2x



2x



2x

# 52

1

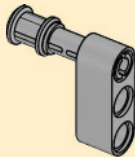

2

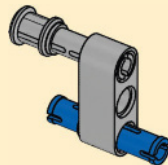

2x

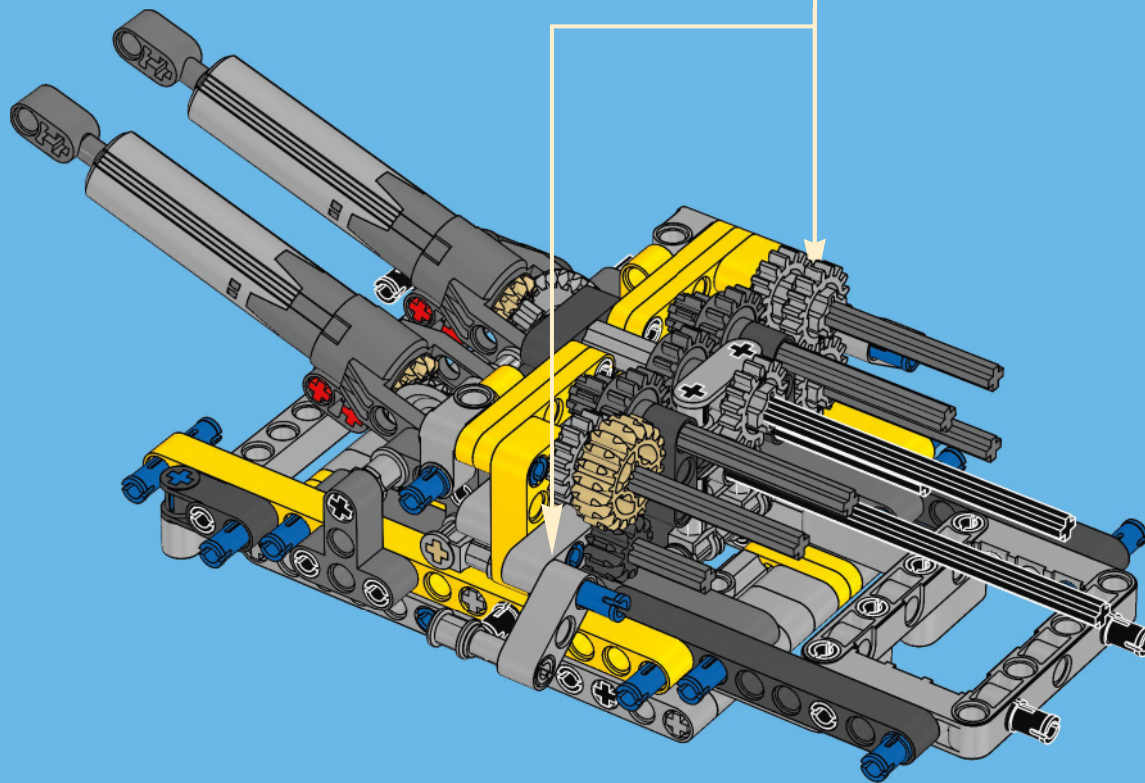

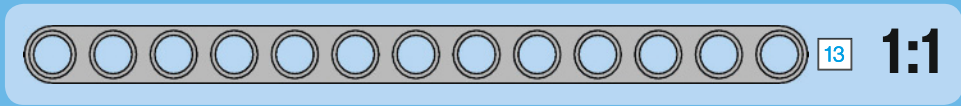
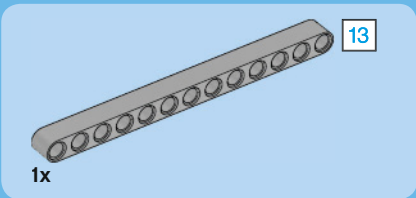

53

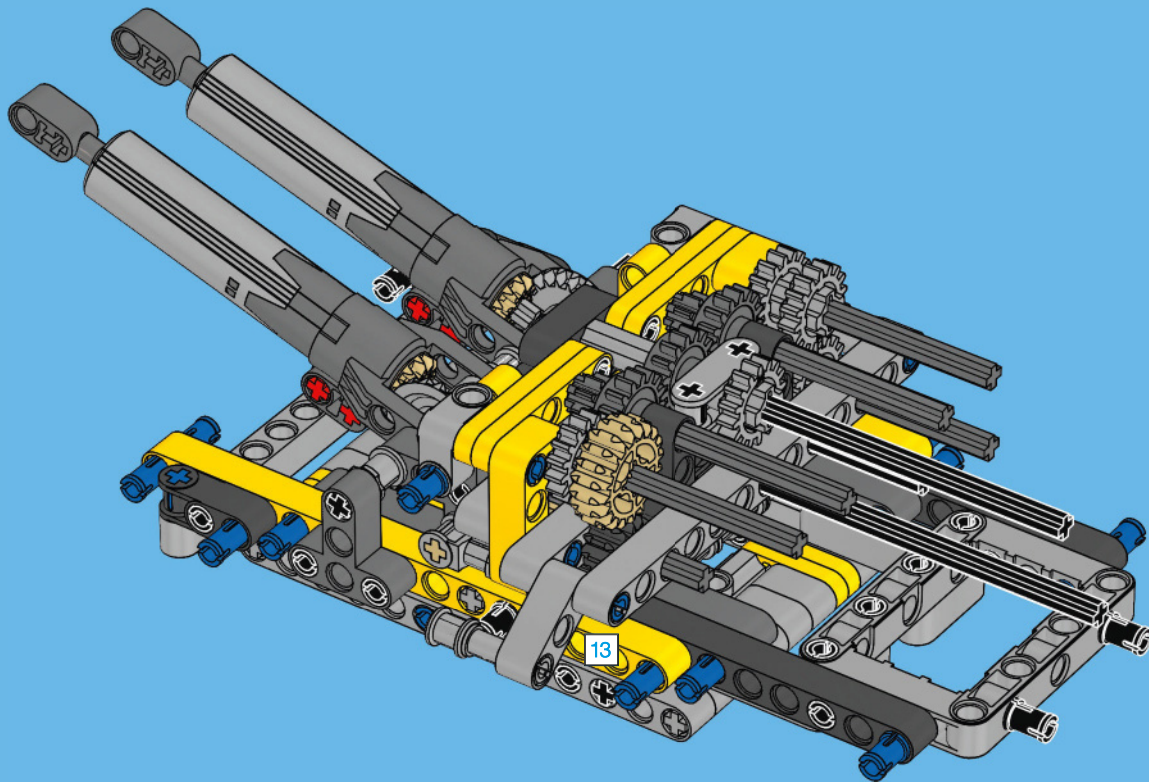



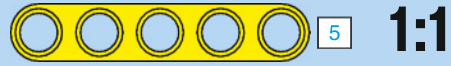
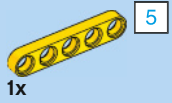

# 54

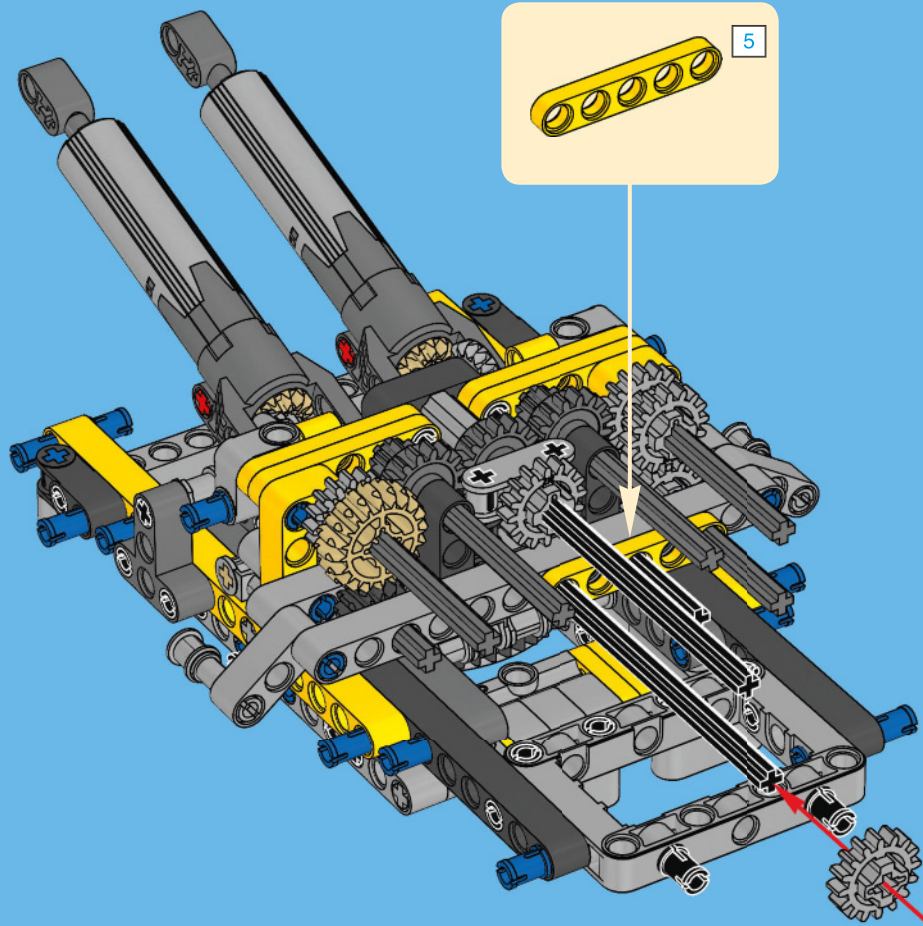

# 55

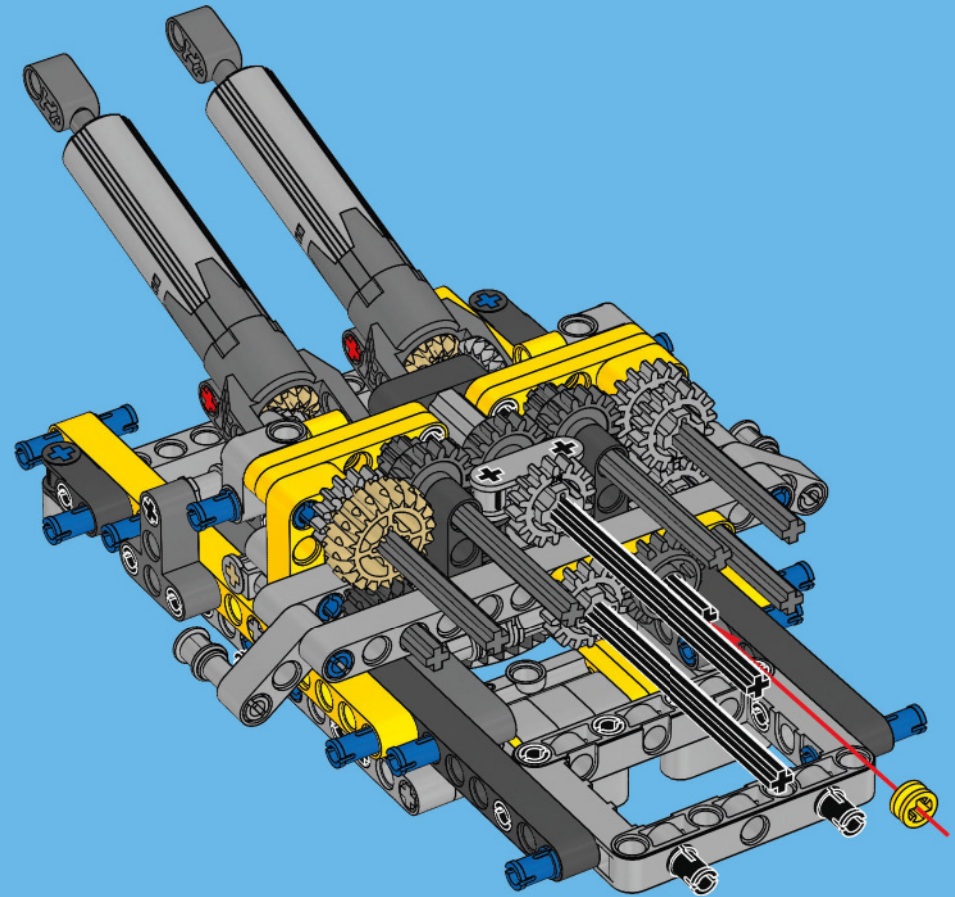

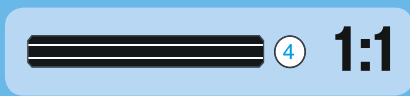
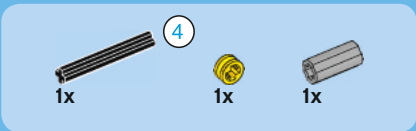

# 56

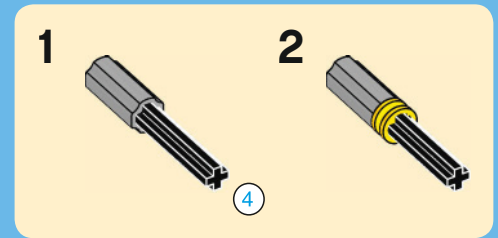
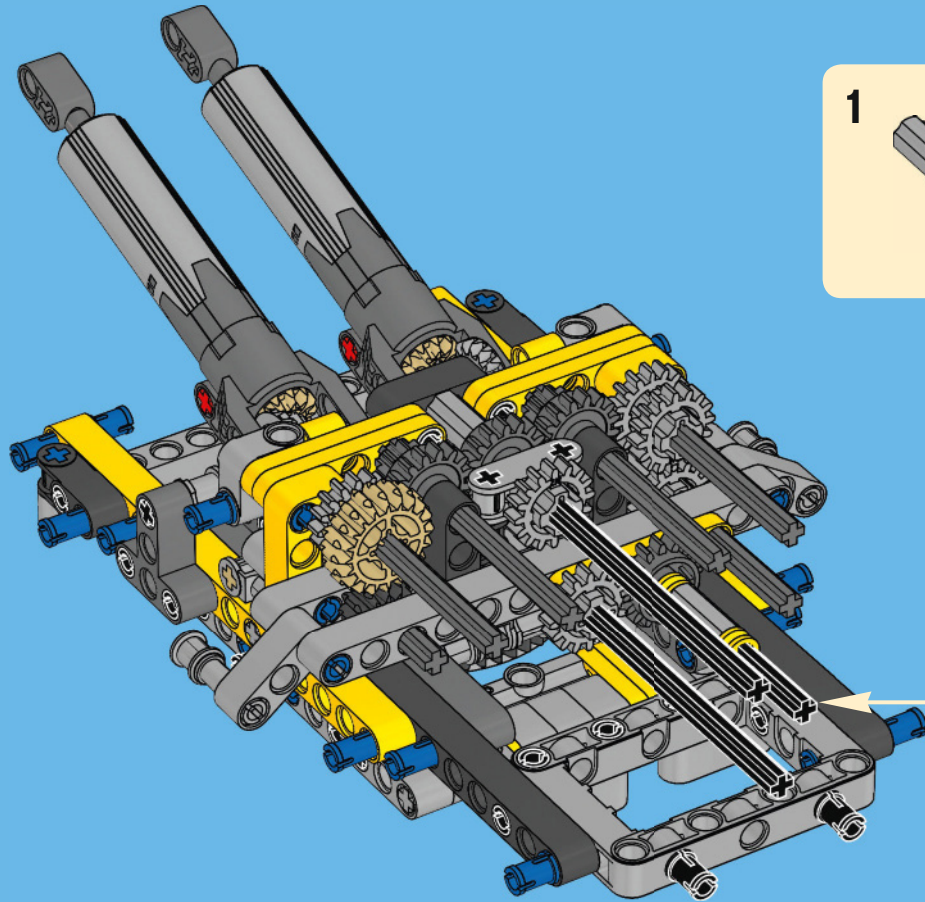



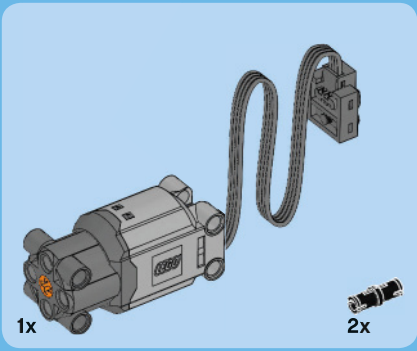

# 57

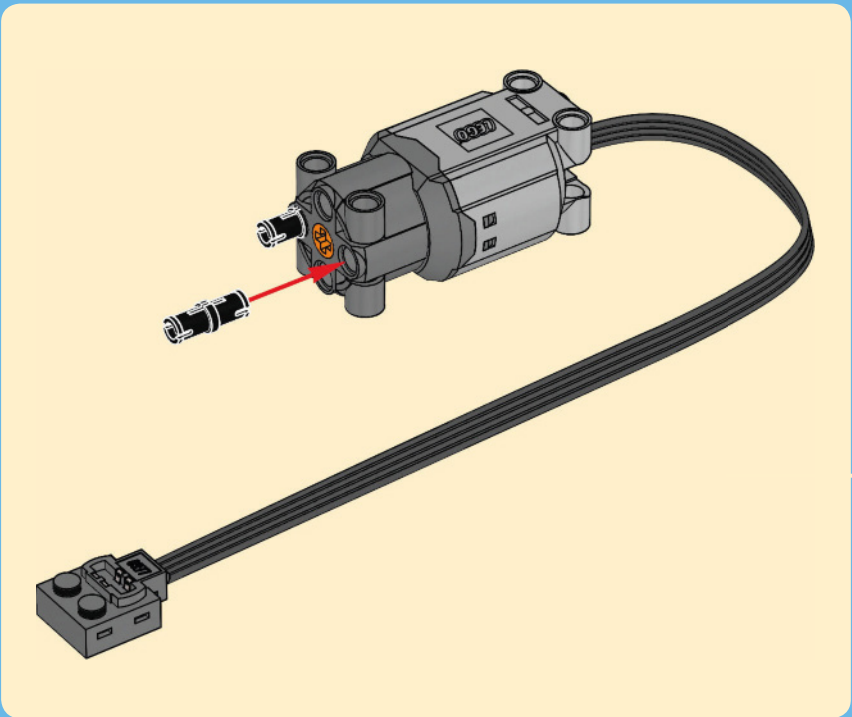
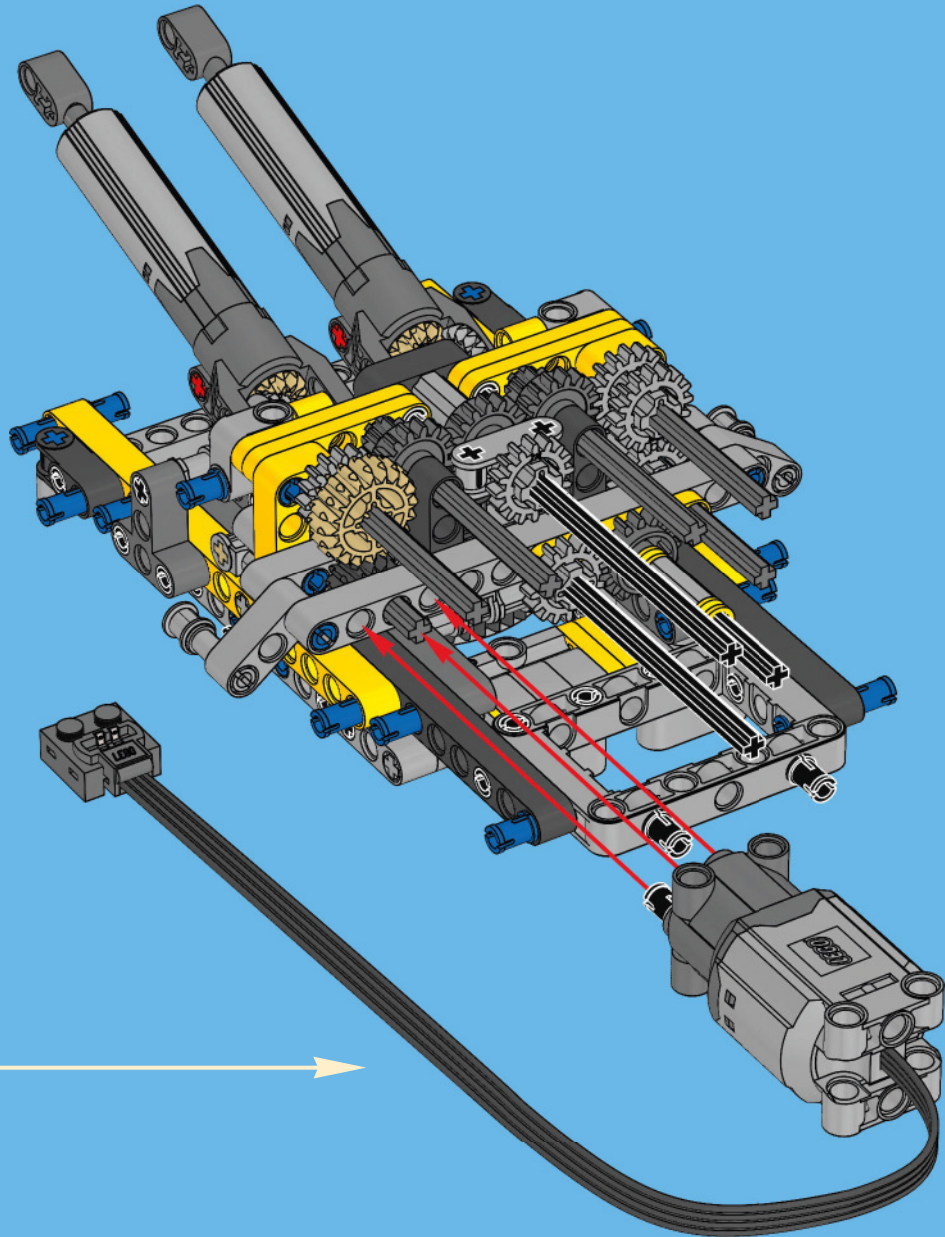



1x

# 58

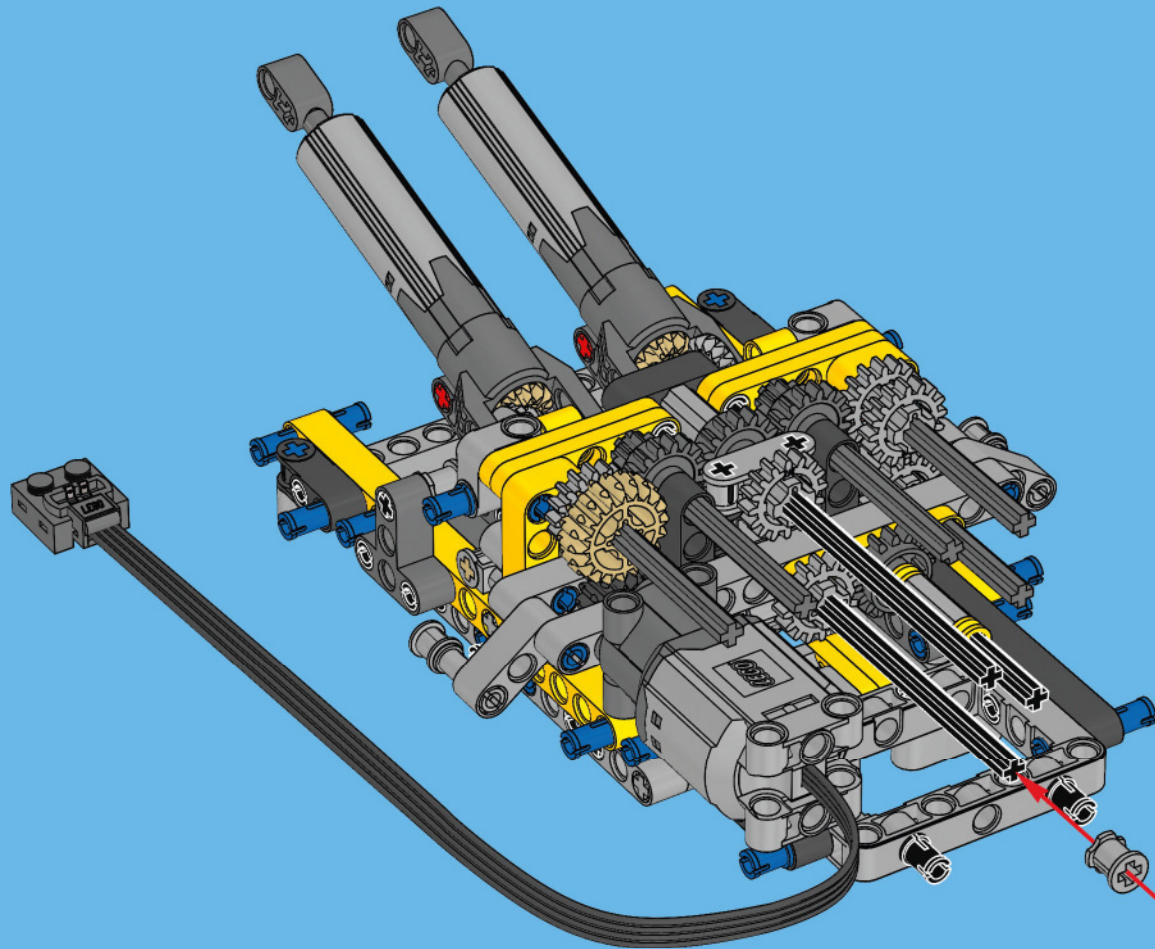



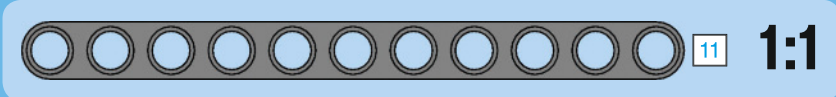
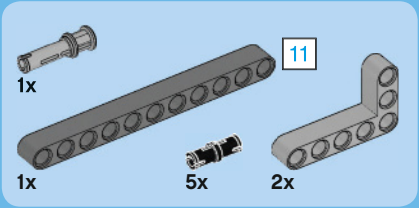

# 59

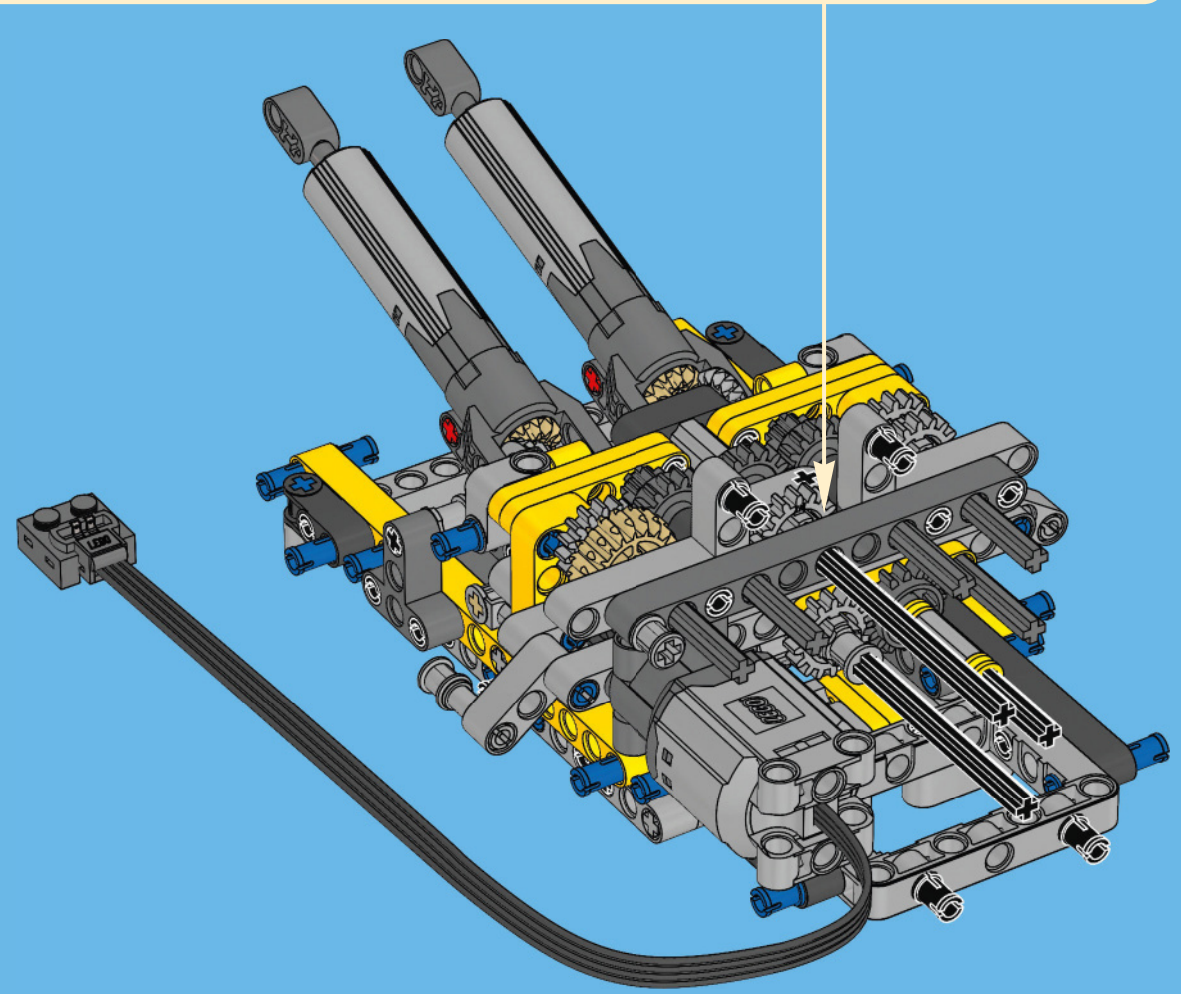
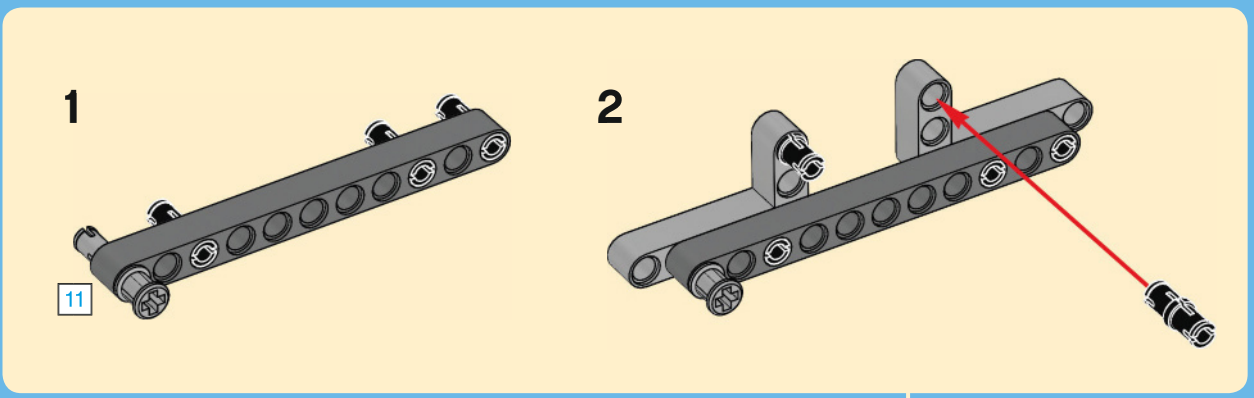

60

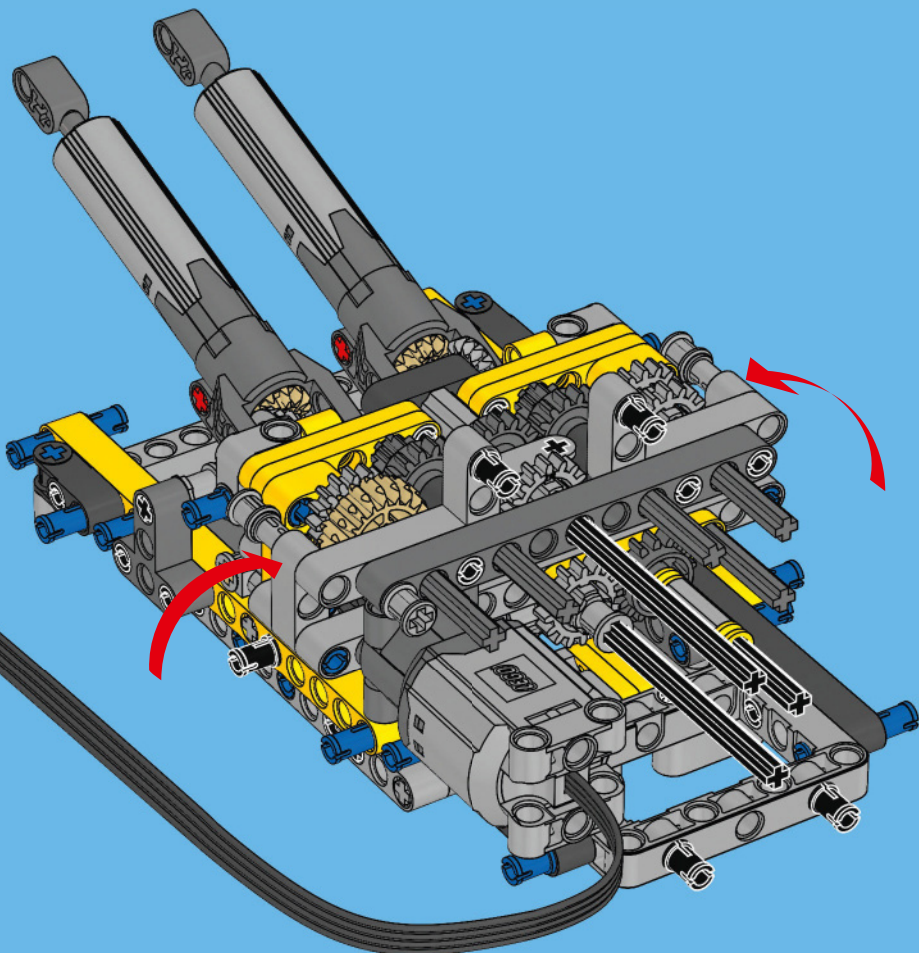

61

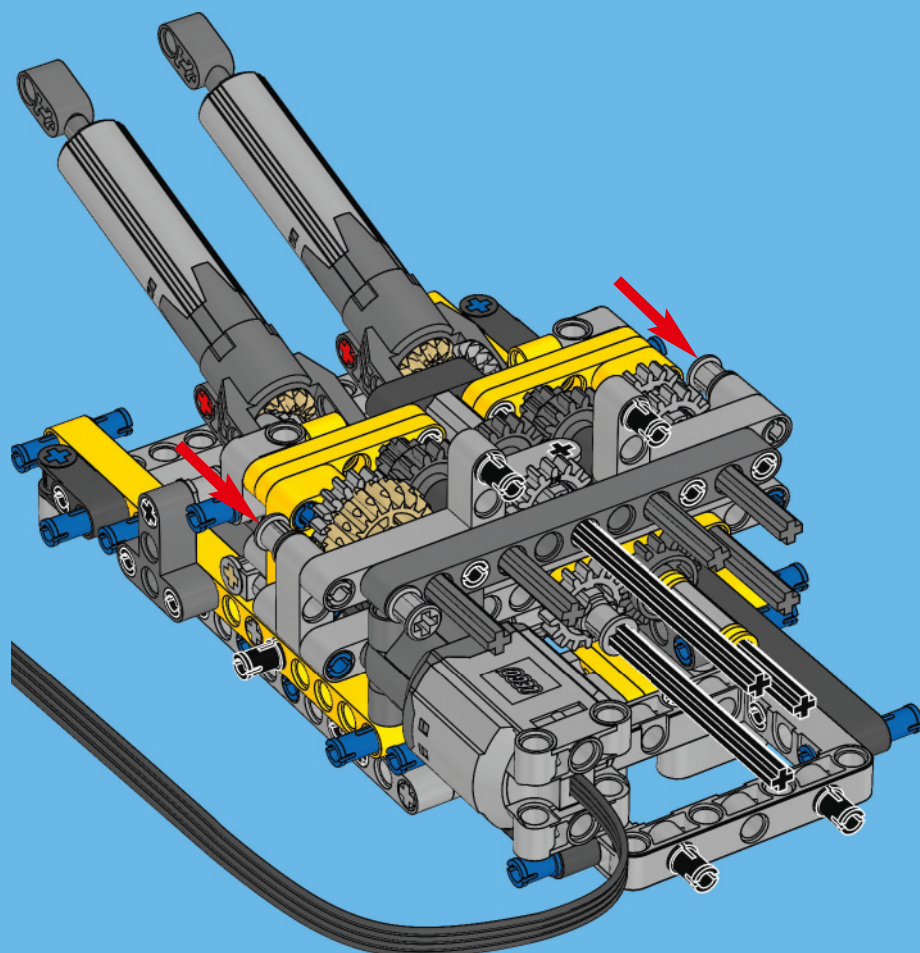



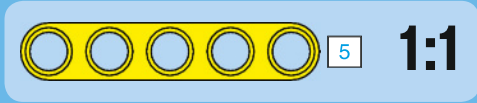

62

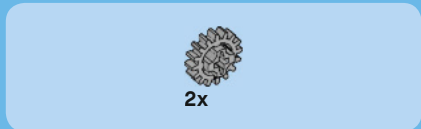
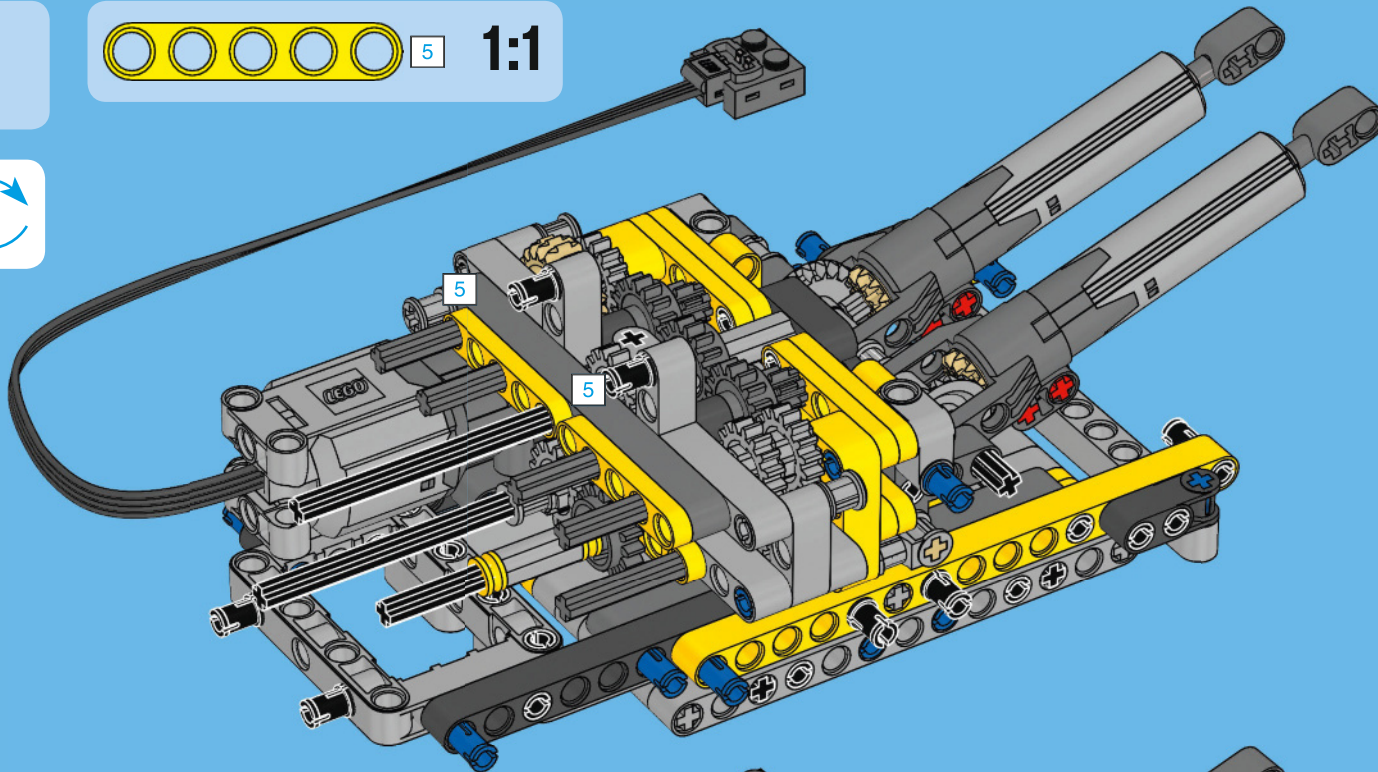

63

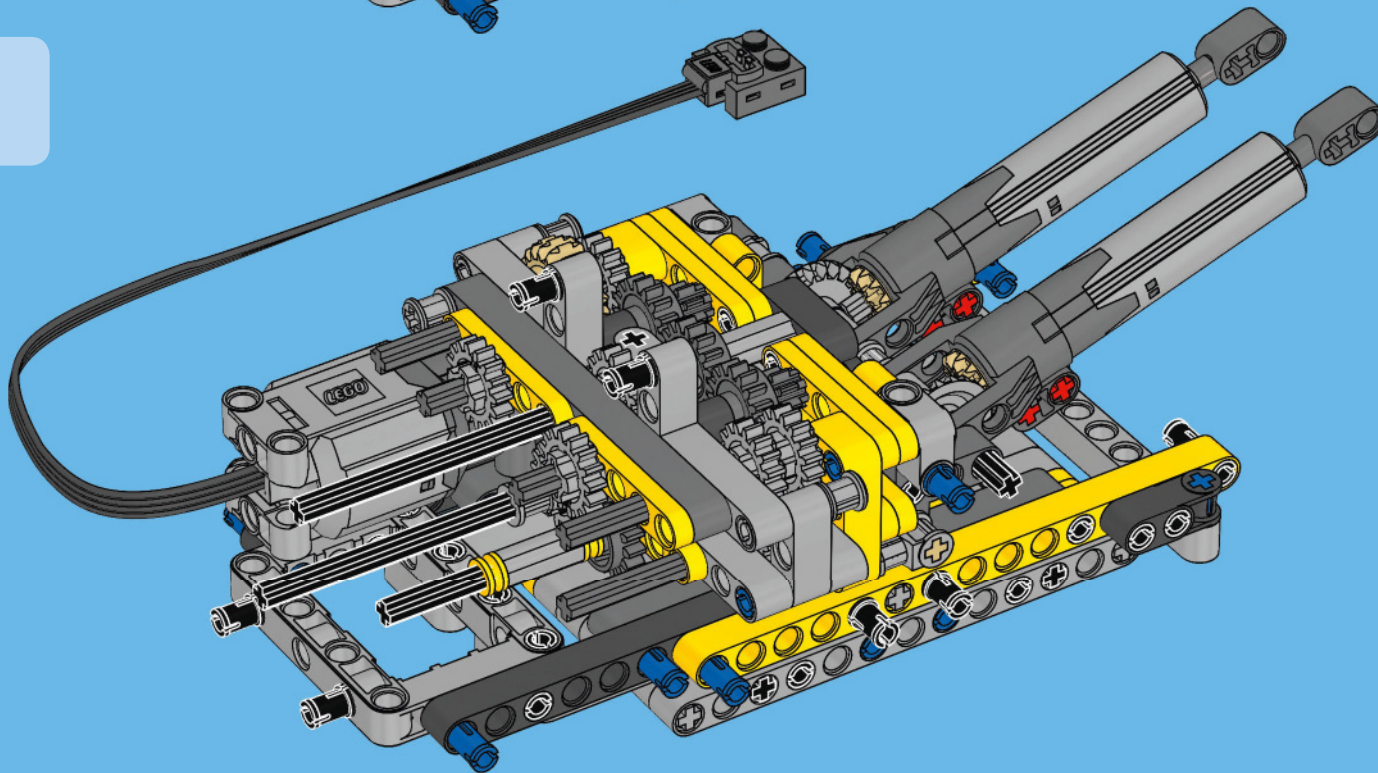



1x

# 64

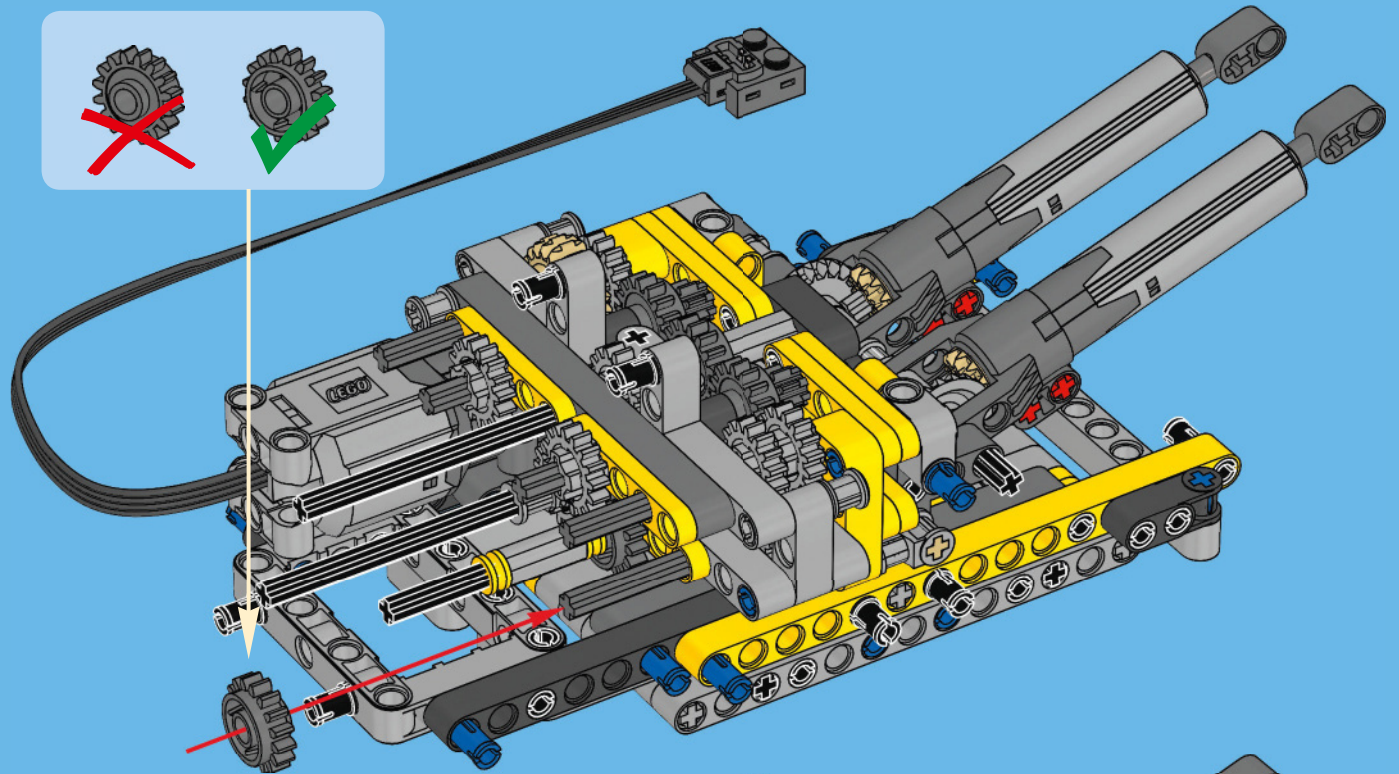
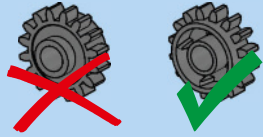

1x



1x

# 65

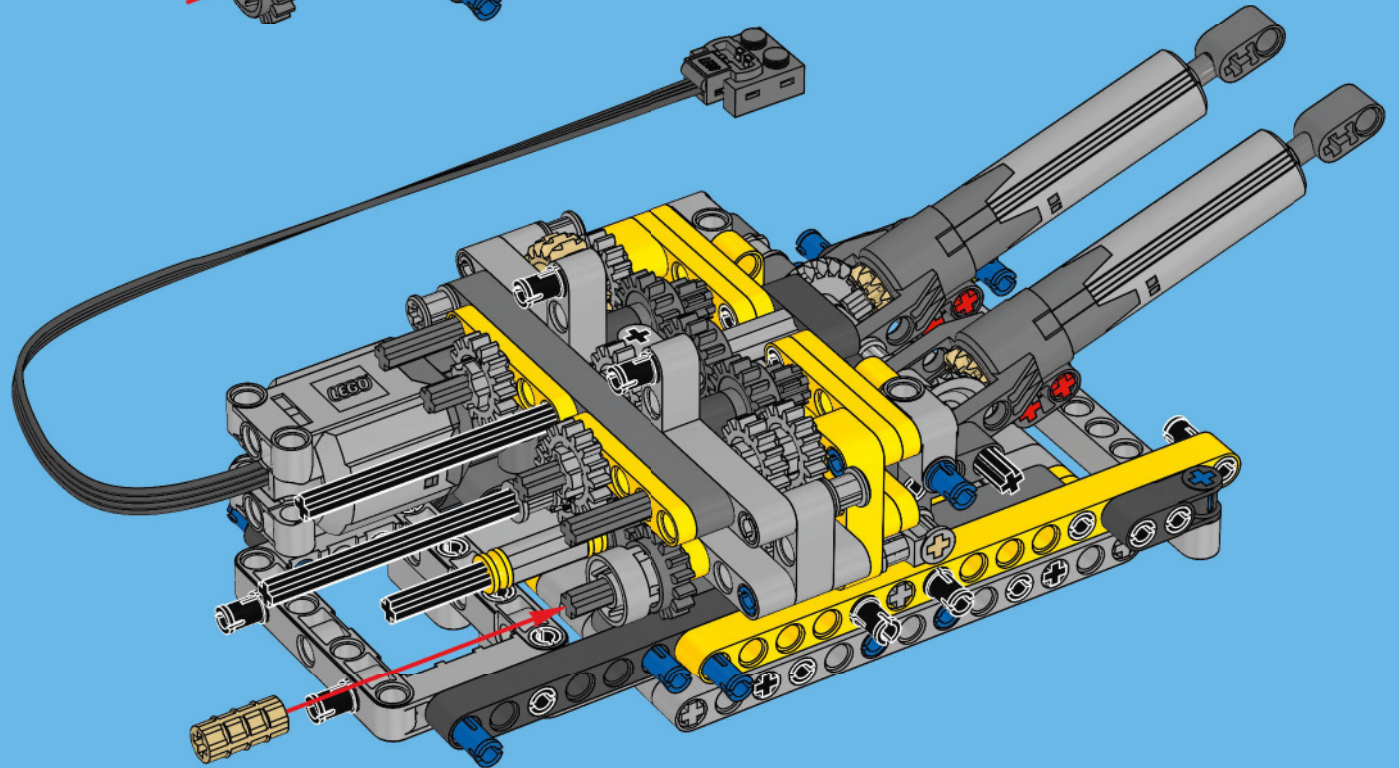



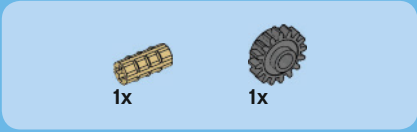

66

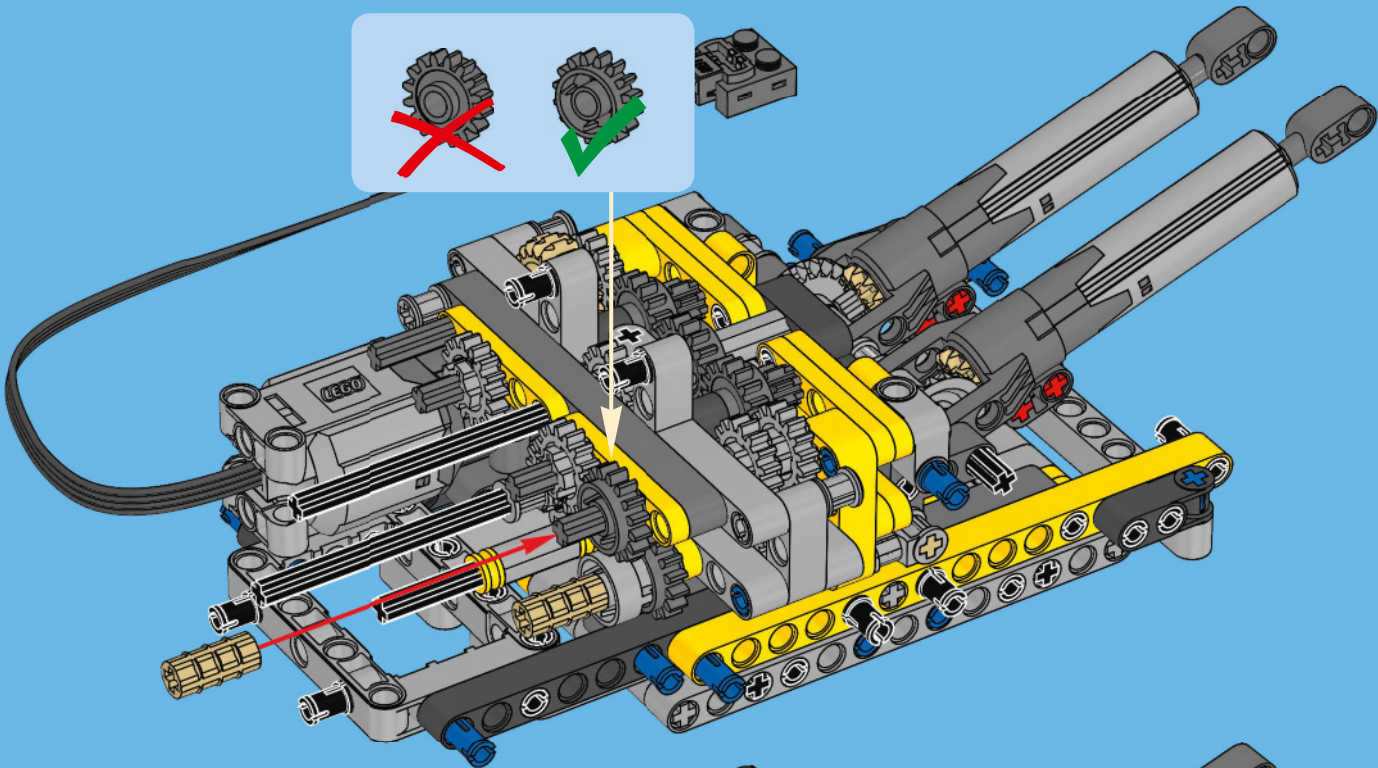
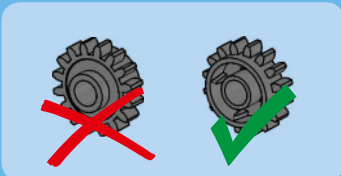

67

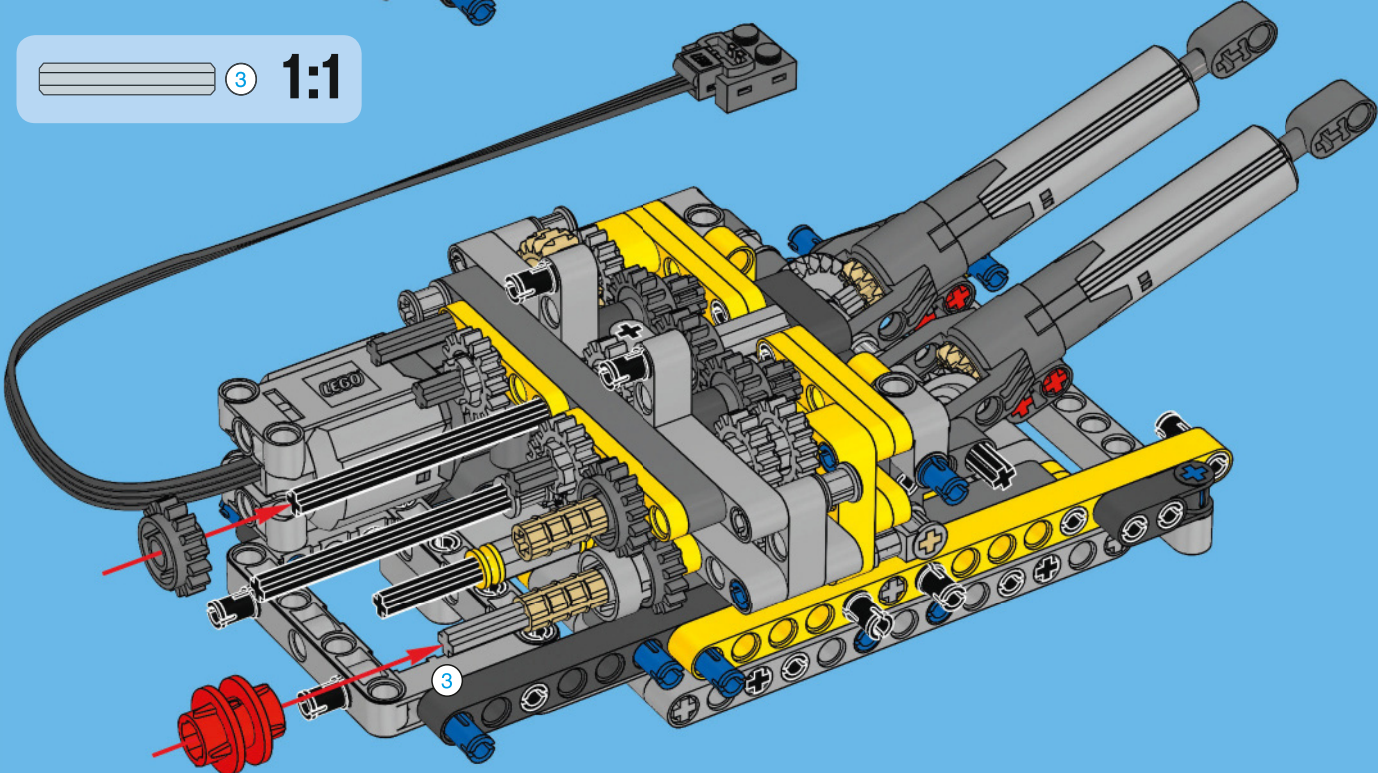
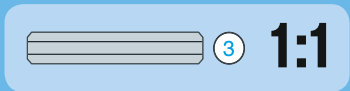



2x

# 68

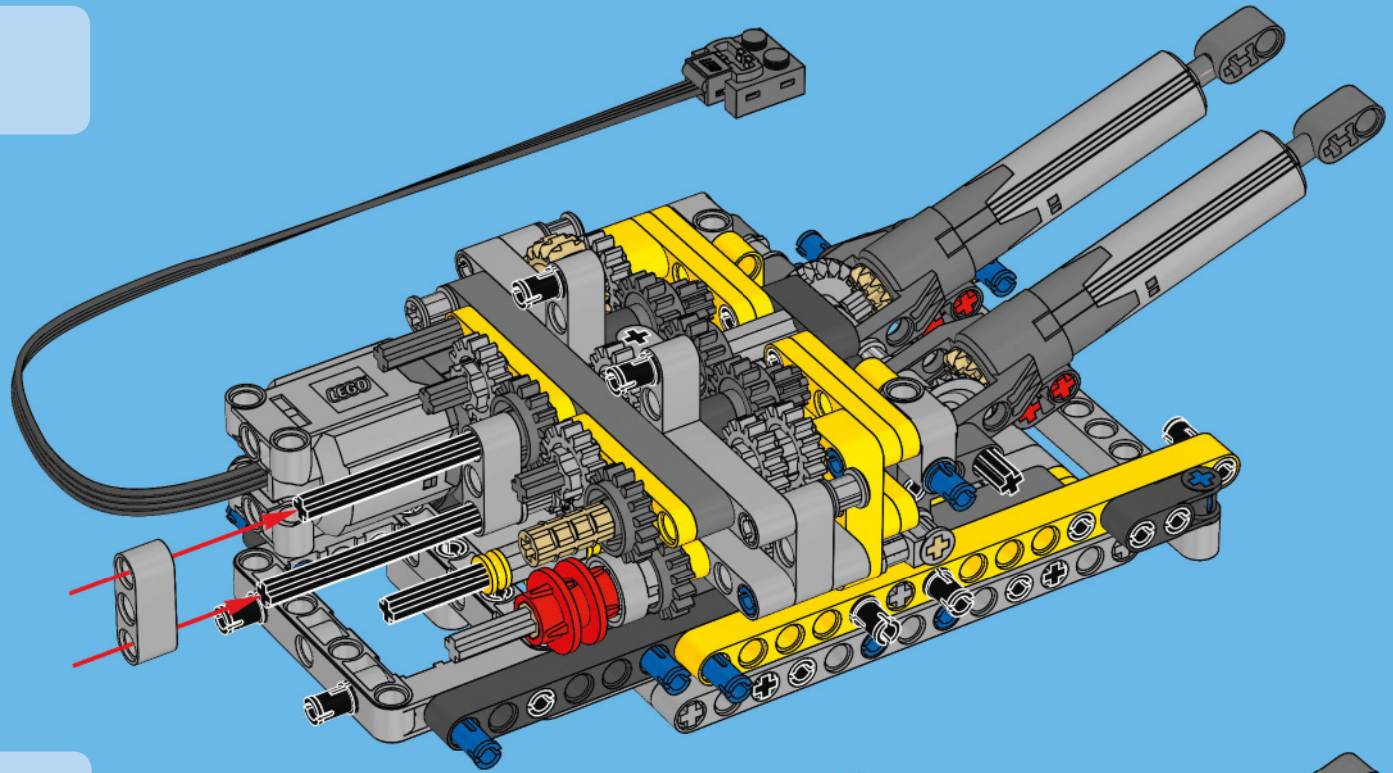

3x

# 69

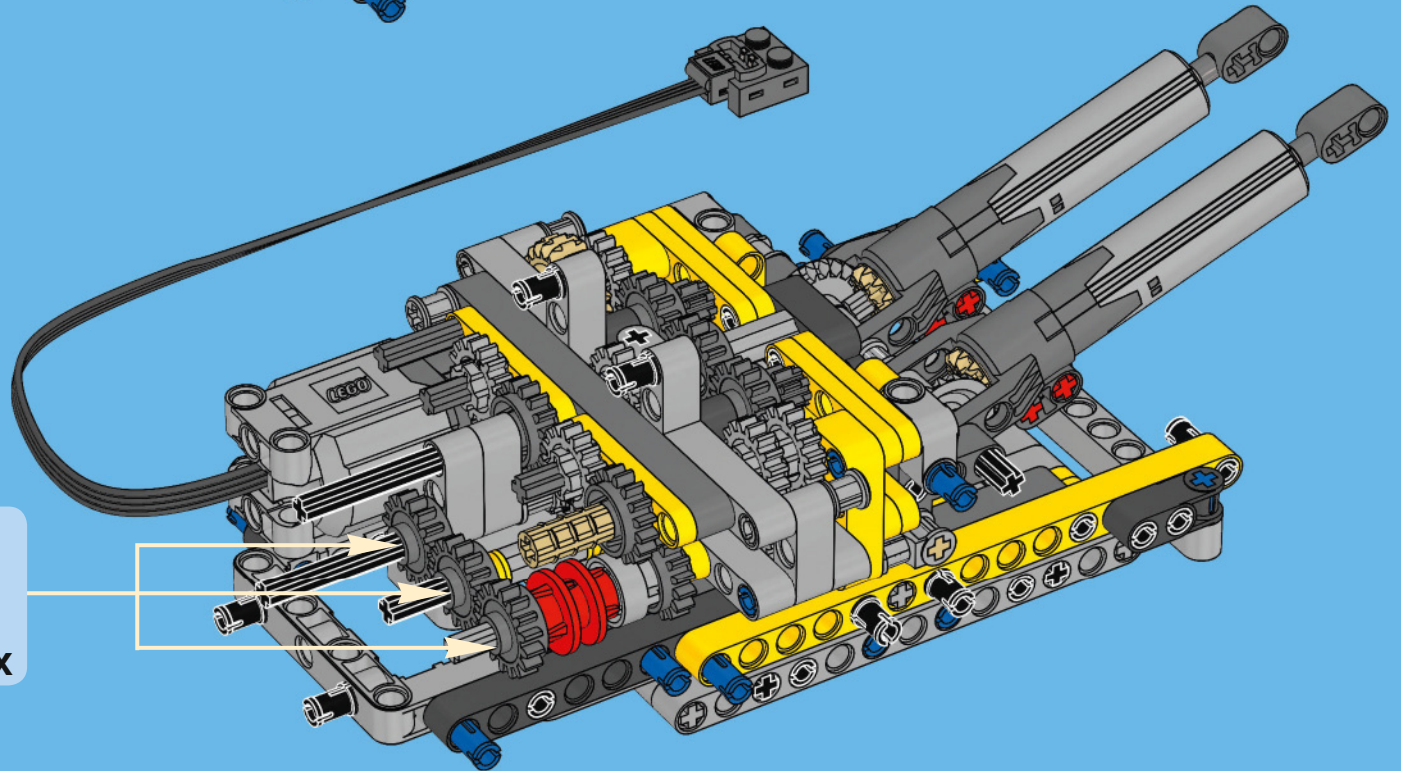

3x



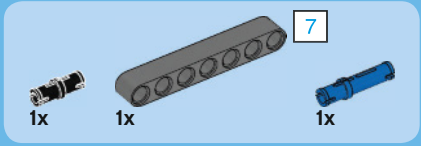
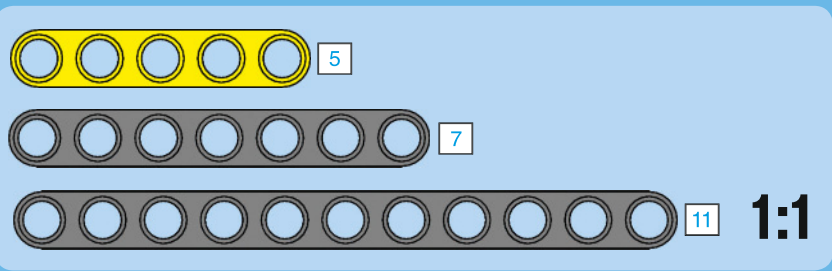
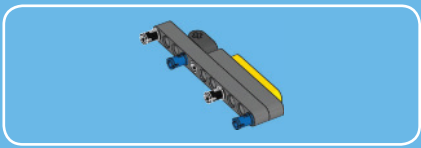

1

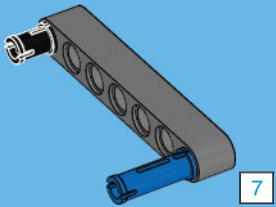

3

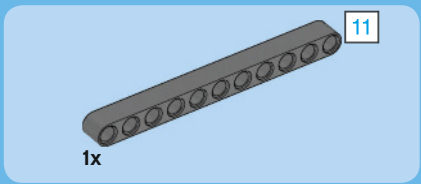
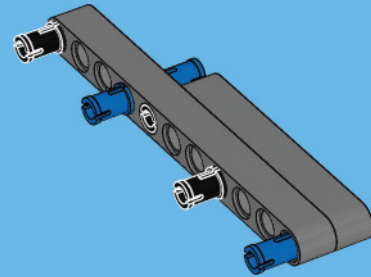

2

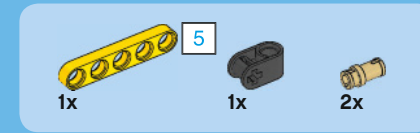
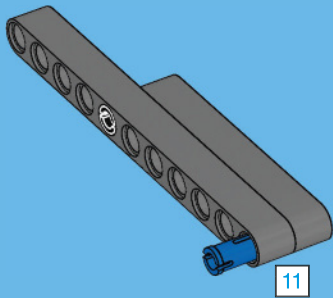

4

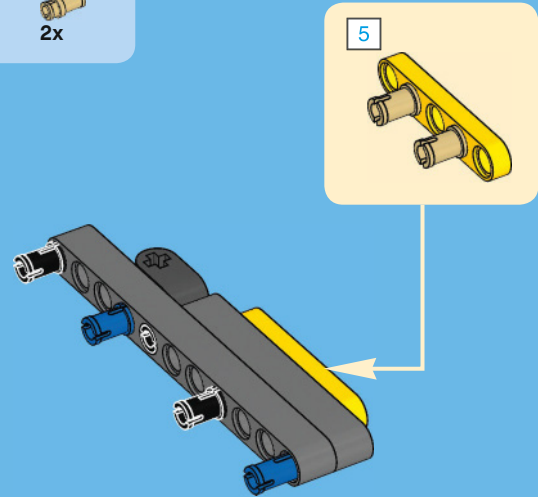

70

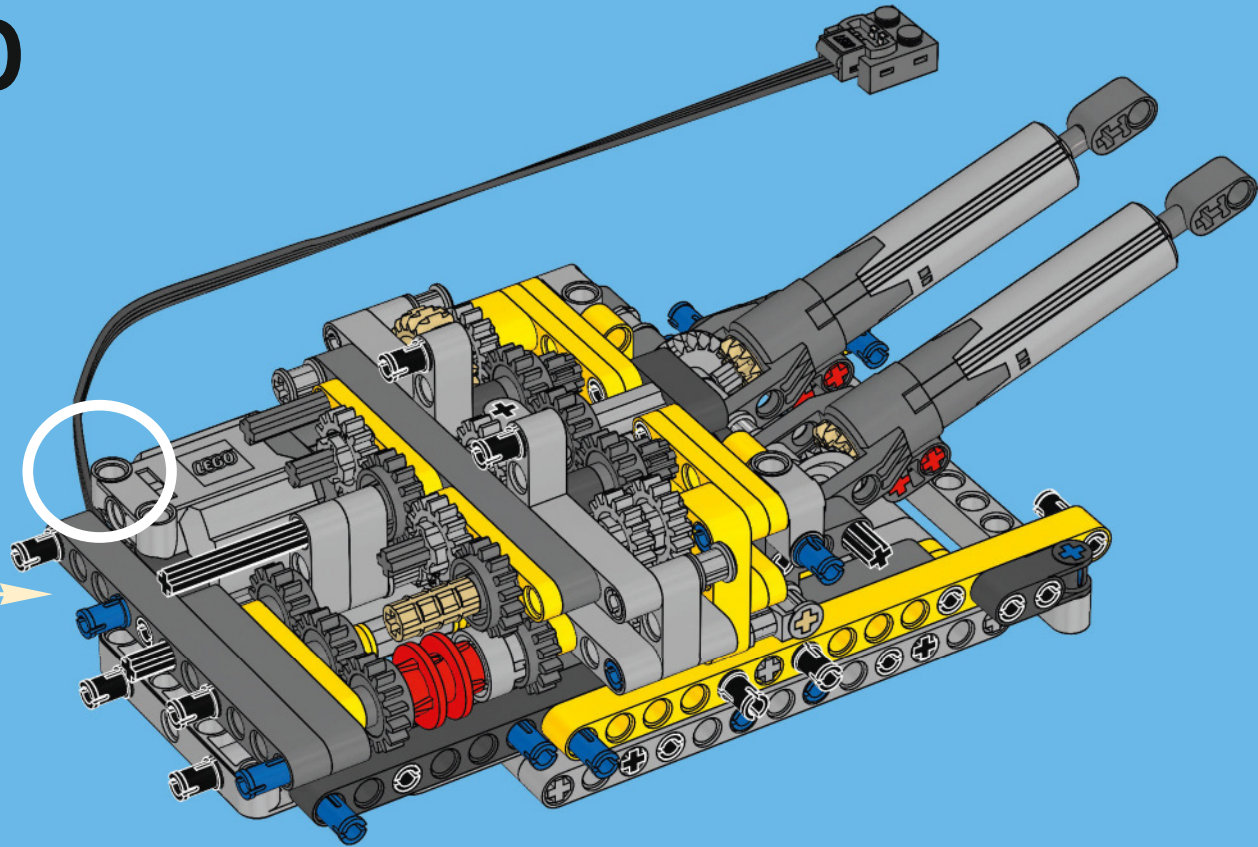





1x

# 71

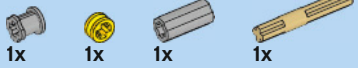
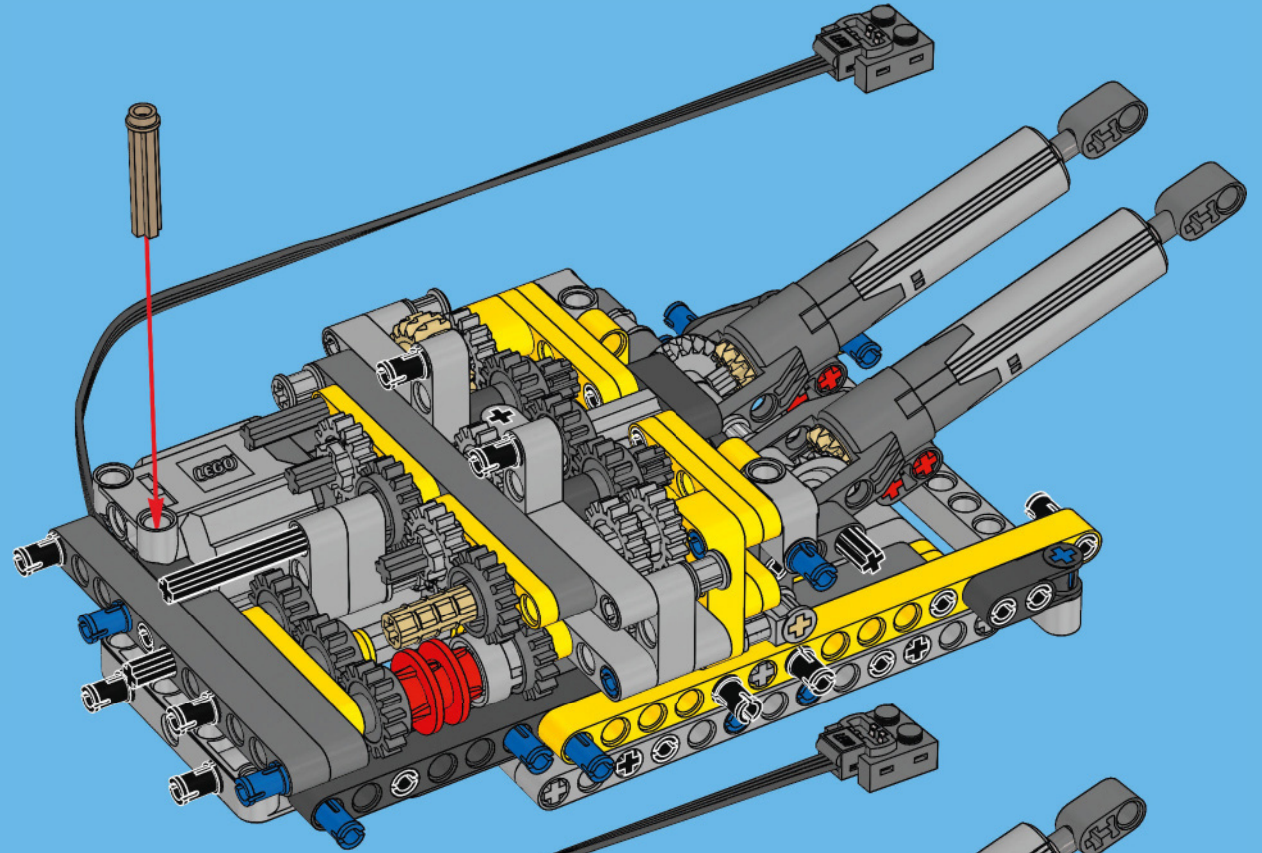

1x

1x

1x

1x

# 72

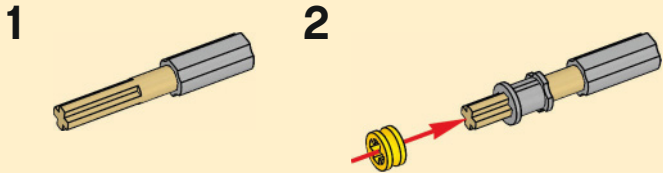

1

2

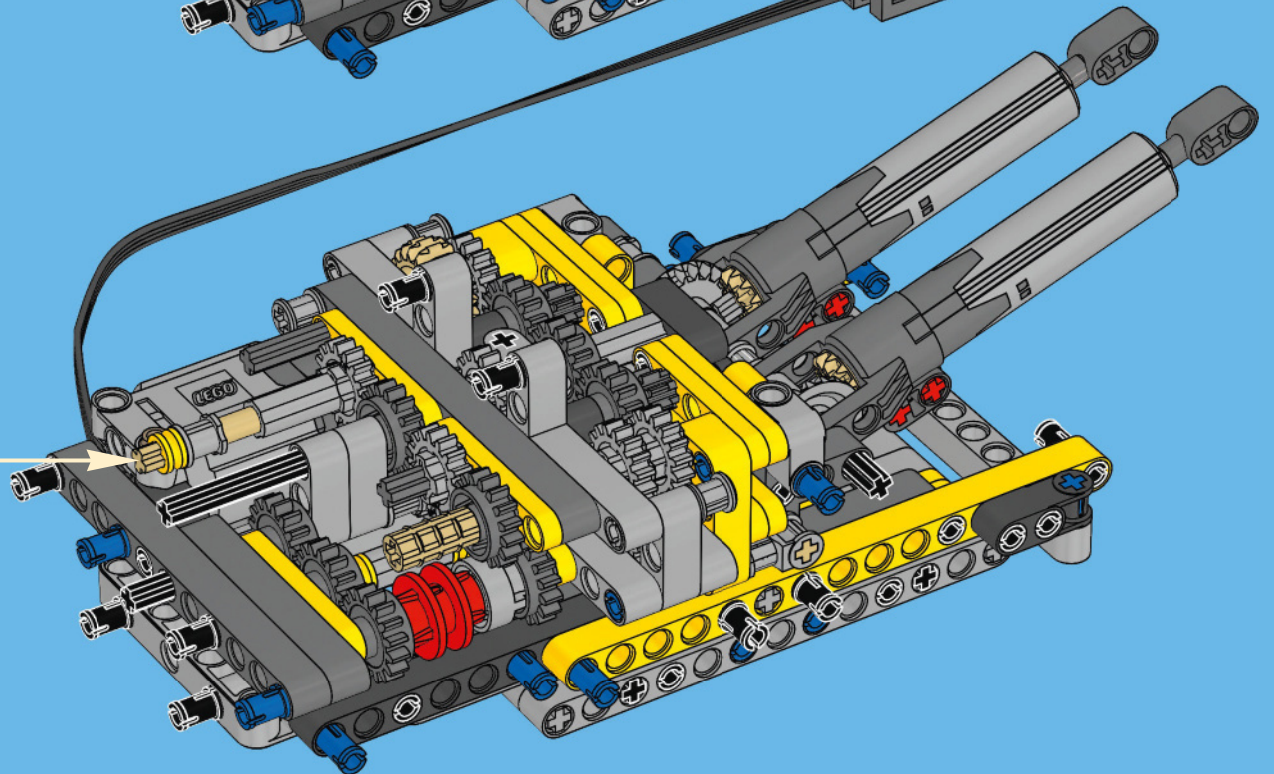

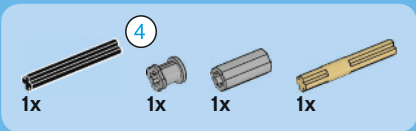

# 73

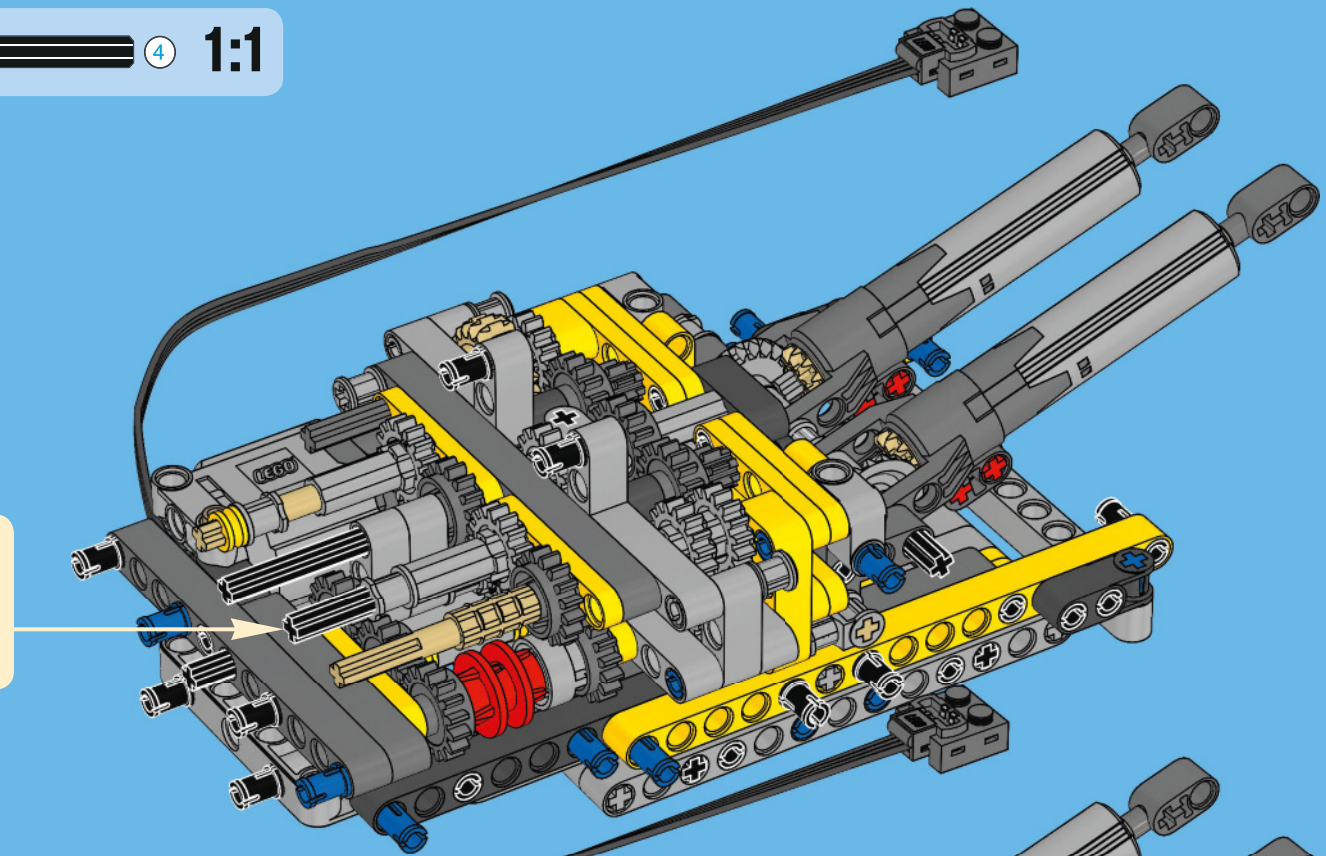
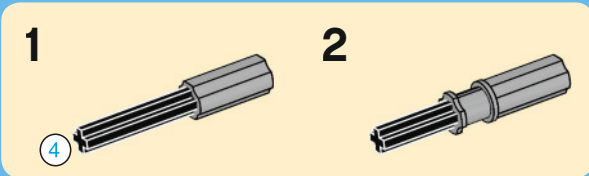

# 74

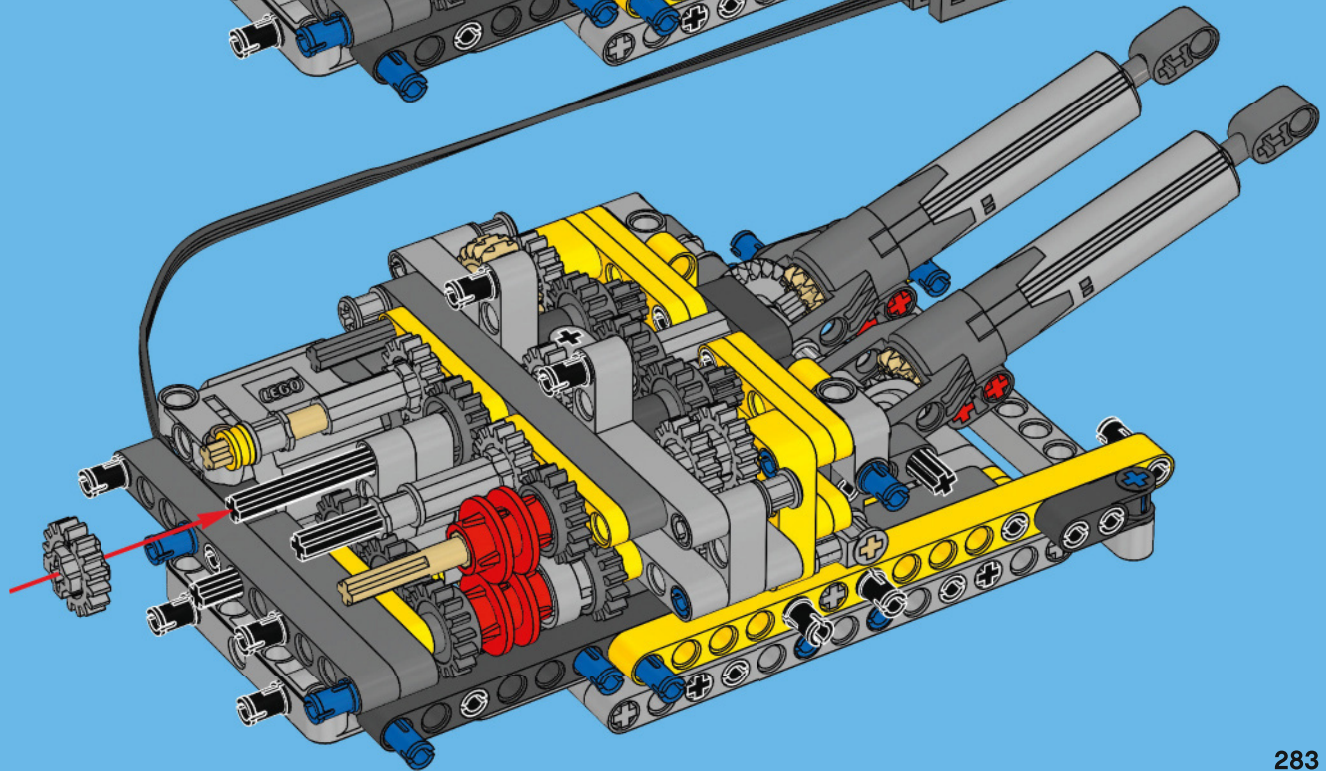





1x

# 75

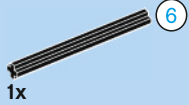
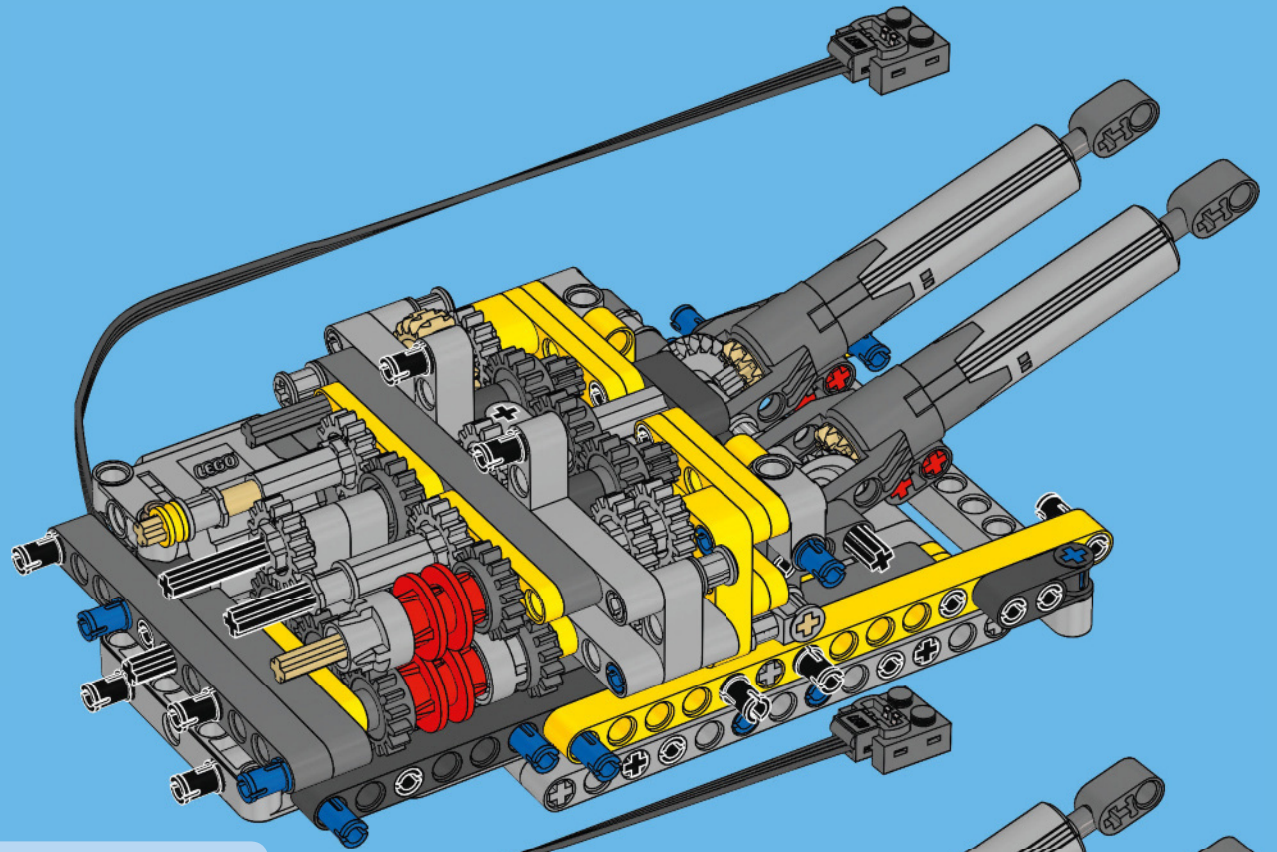

1x



1x



6

1:1

# 76

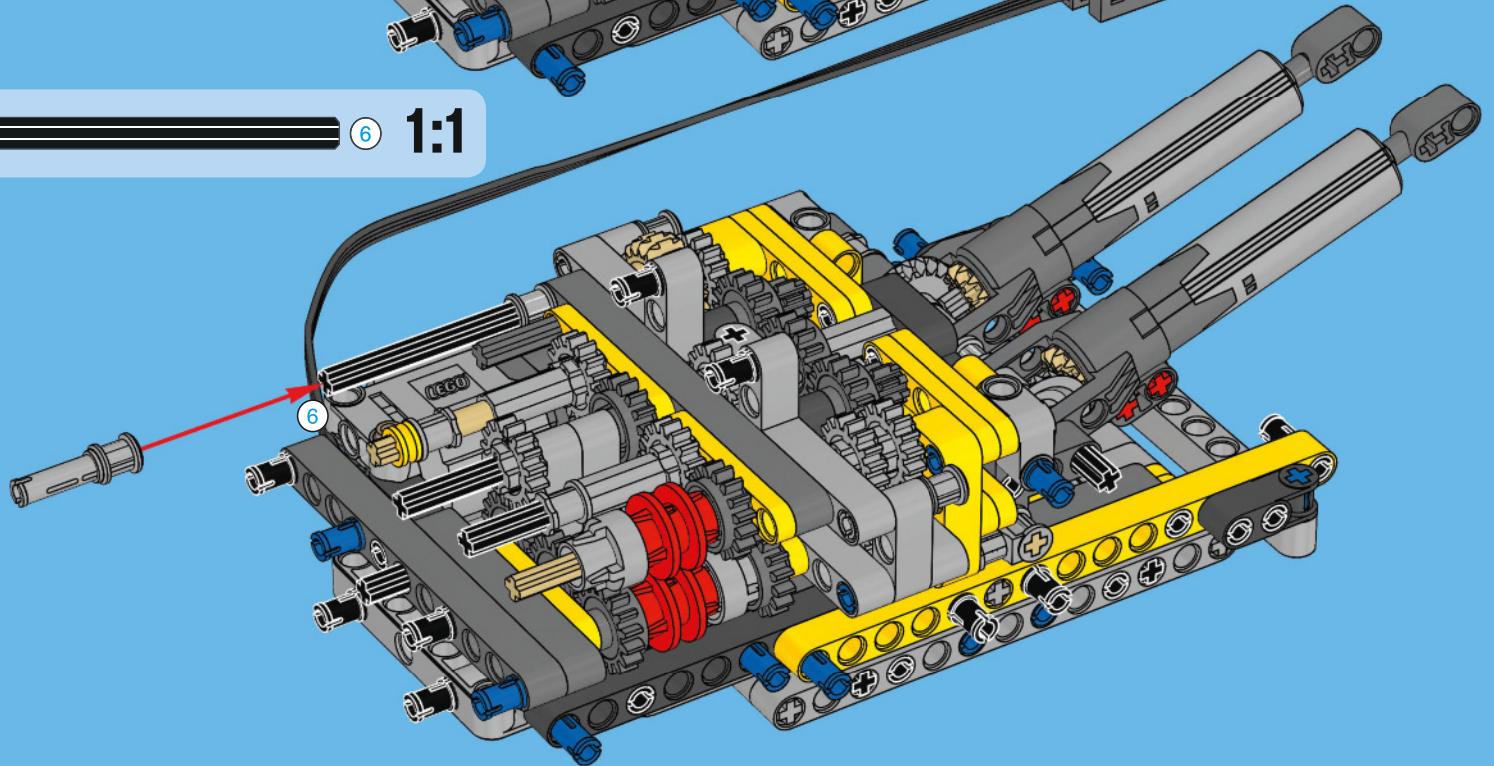

6



3x

# 77



3x

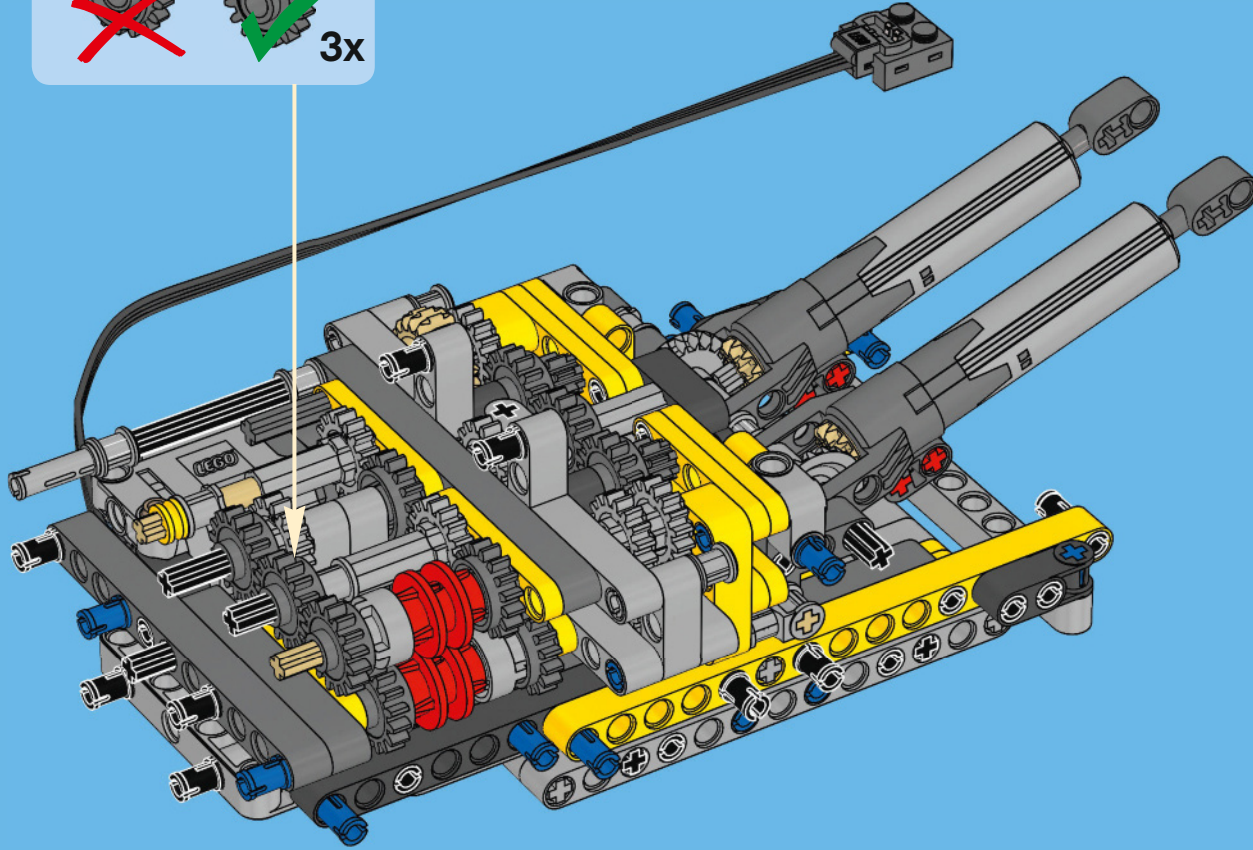



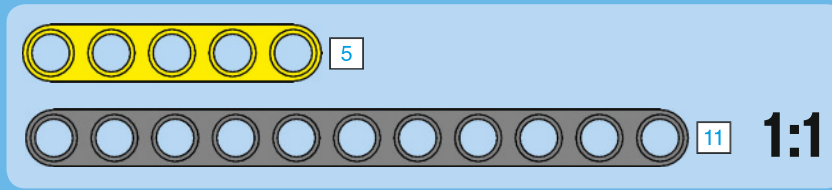
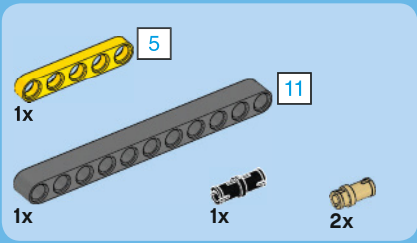

78

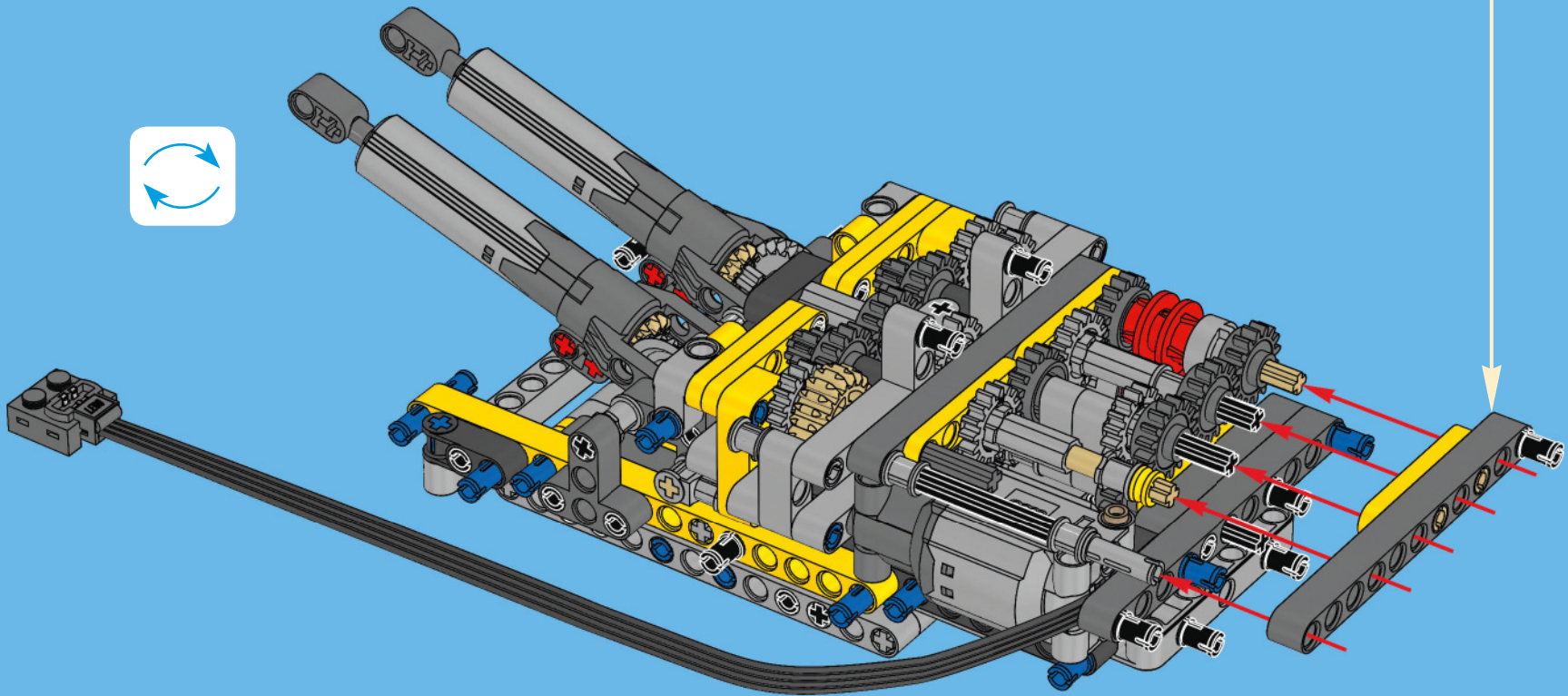
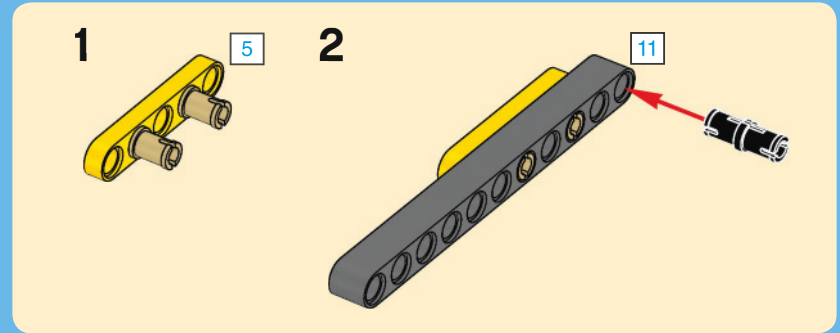

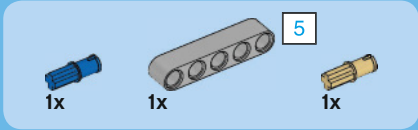
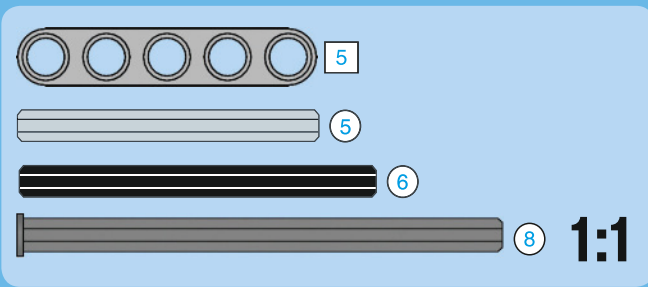
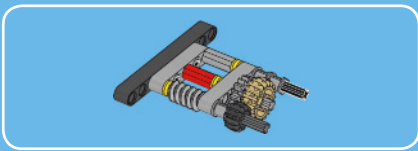

1

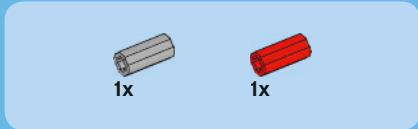
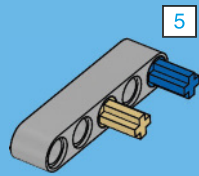

2

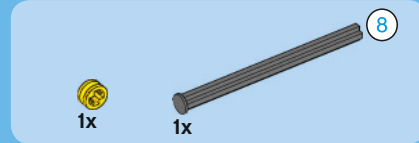
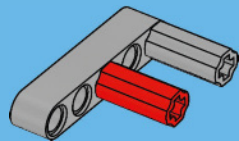

3

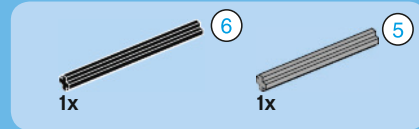
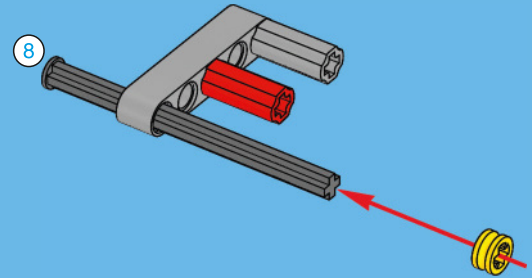

4

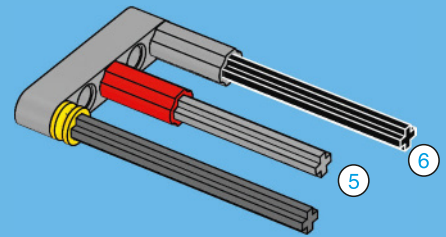





1x



2x

# 5

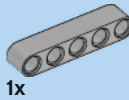
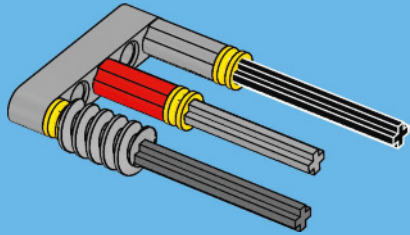

1x

5



5

1:1

# 6

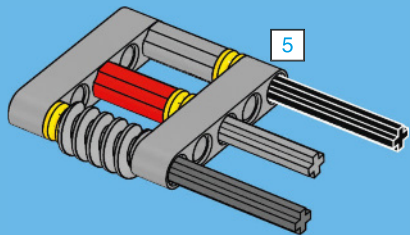

5



2x



1x

# 7

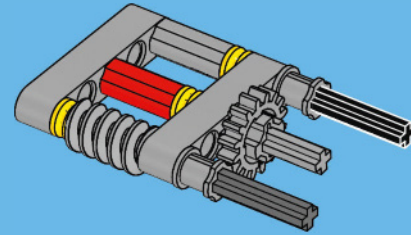

1x



1x



1x

# 8

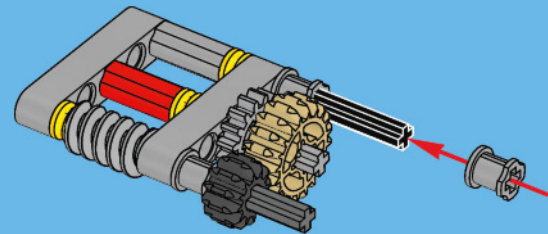



2x

9

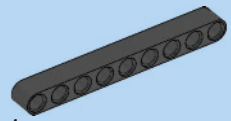
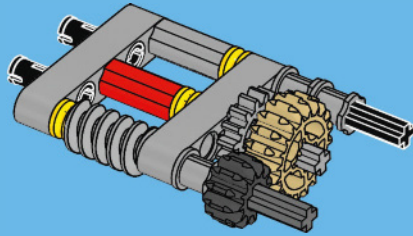

1x

9

10



9

1:1

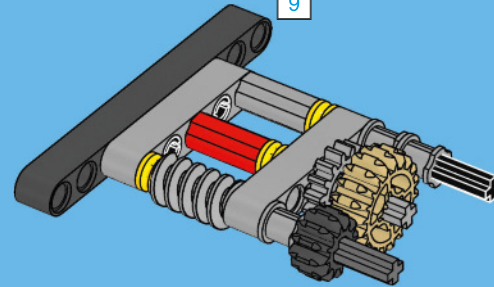

9

79

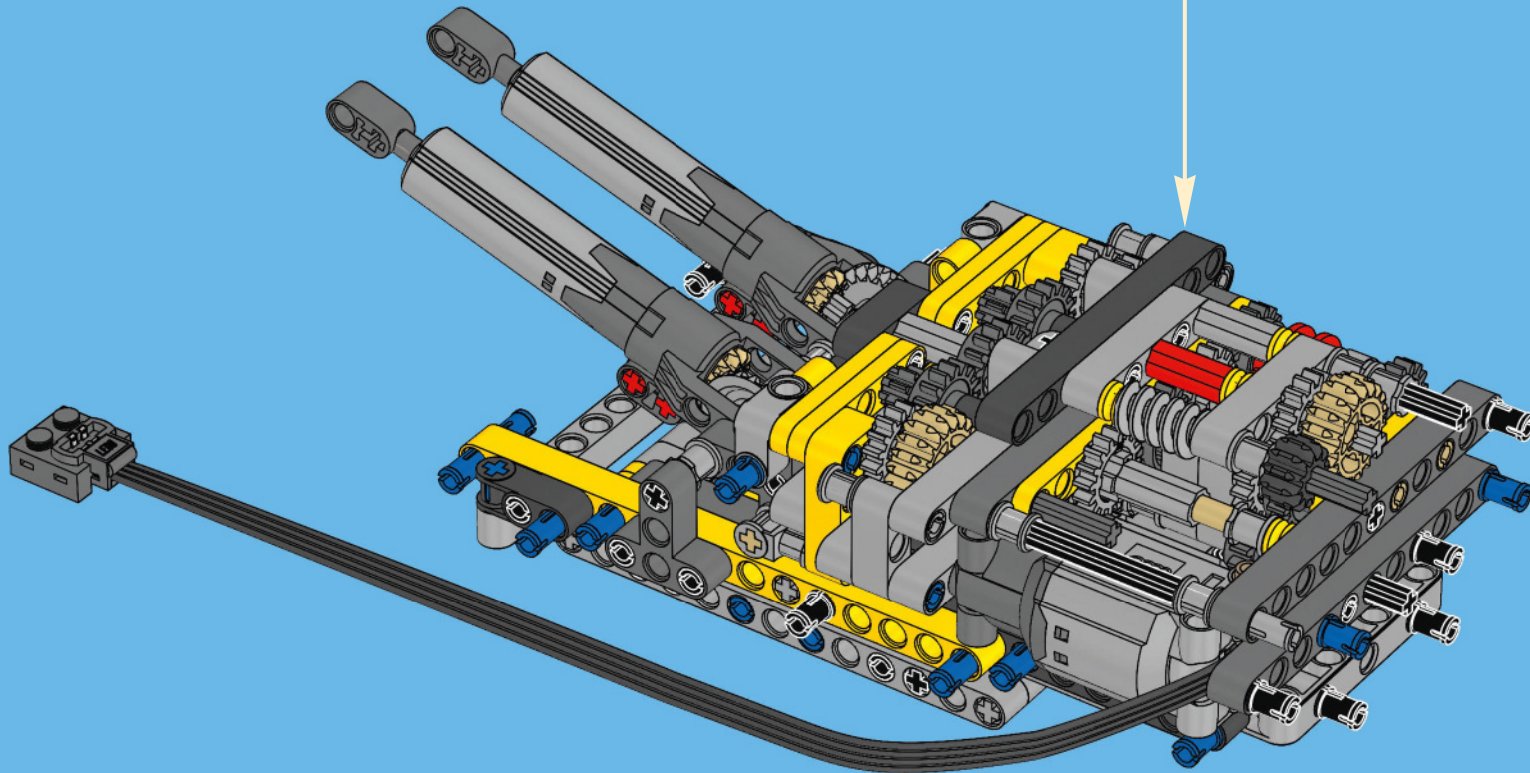



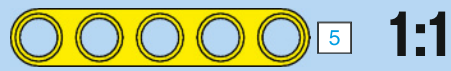
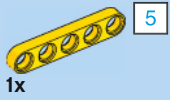

80

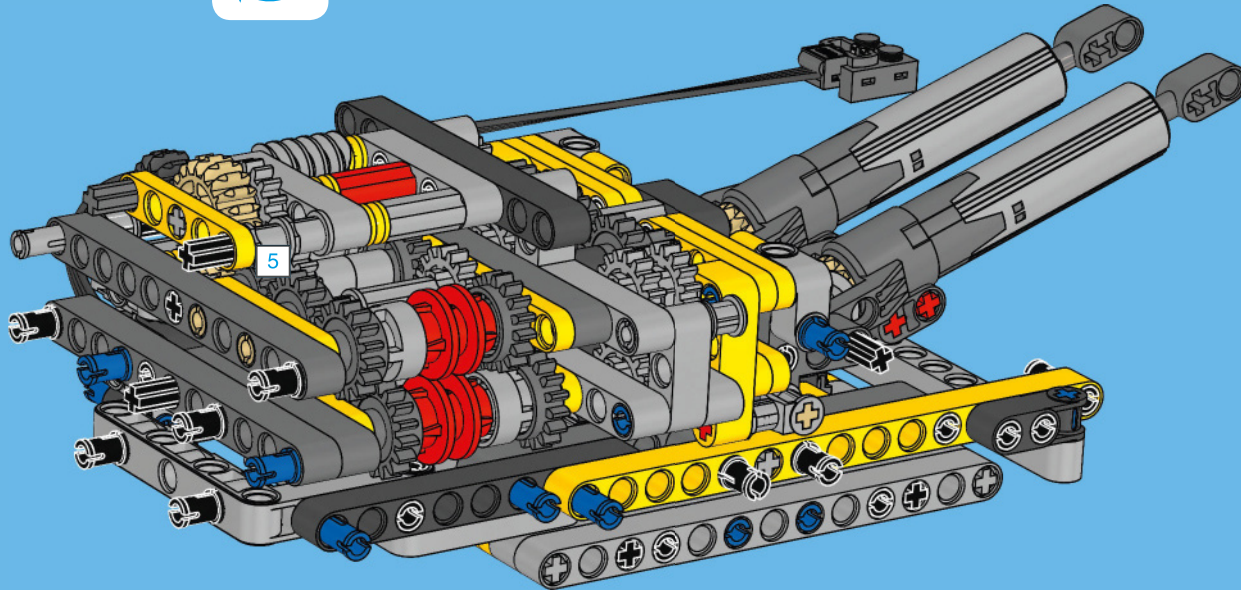

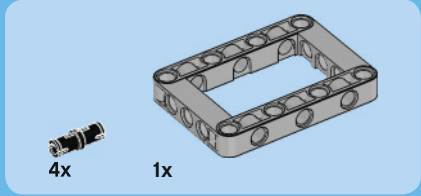
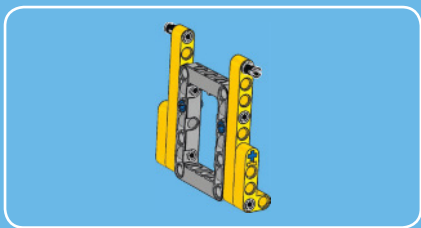

1

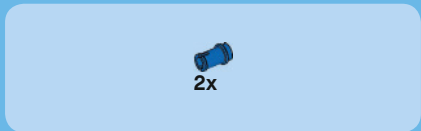
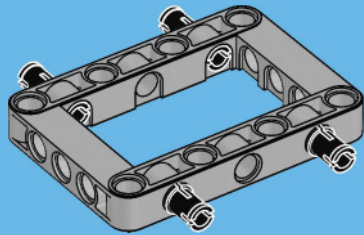

2

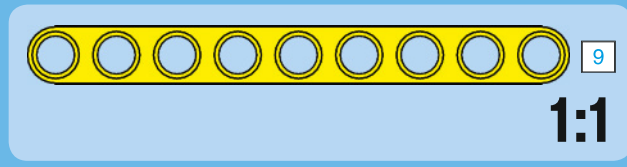
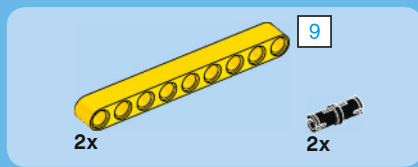
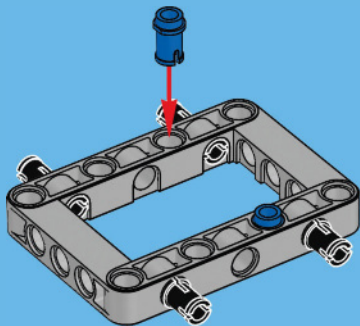

3

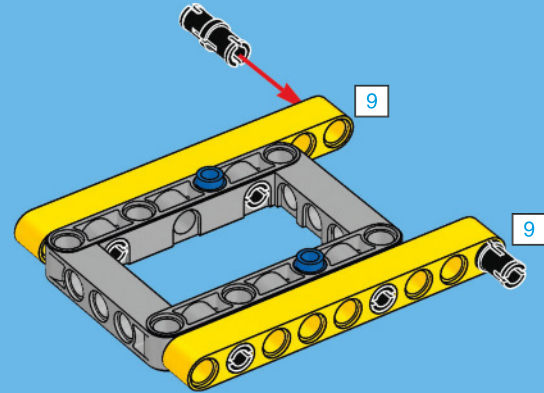

4

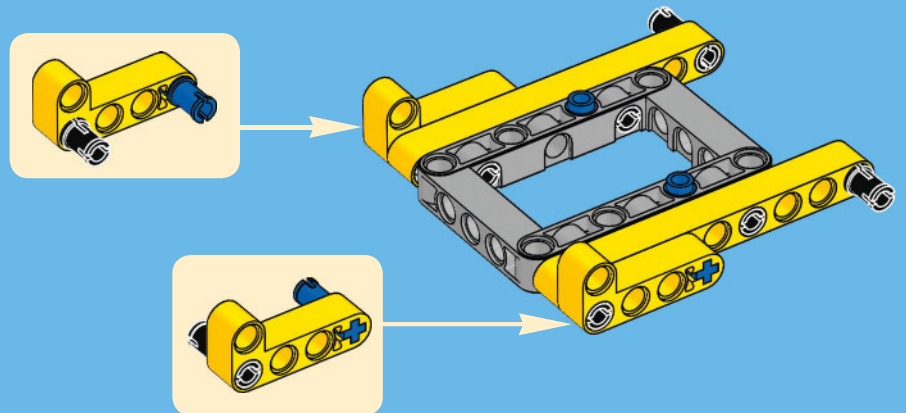



5

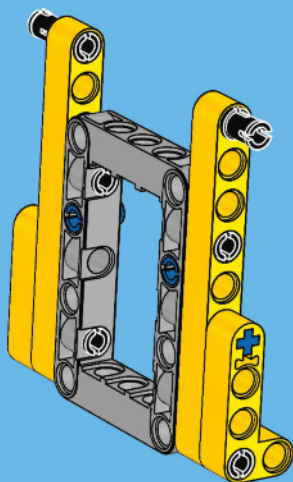

81

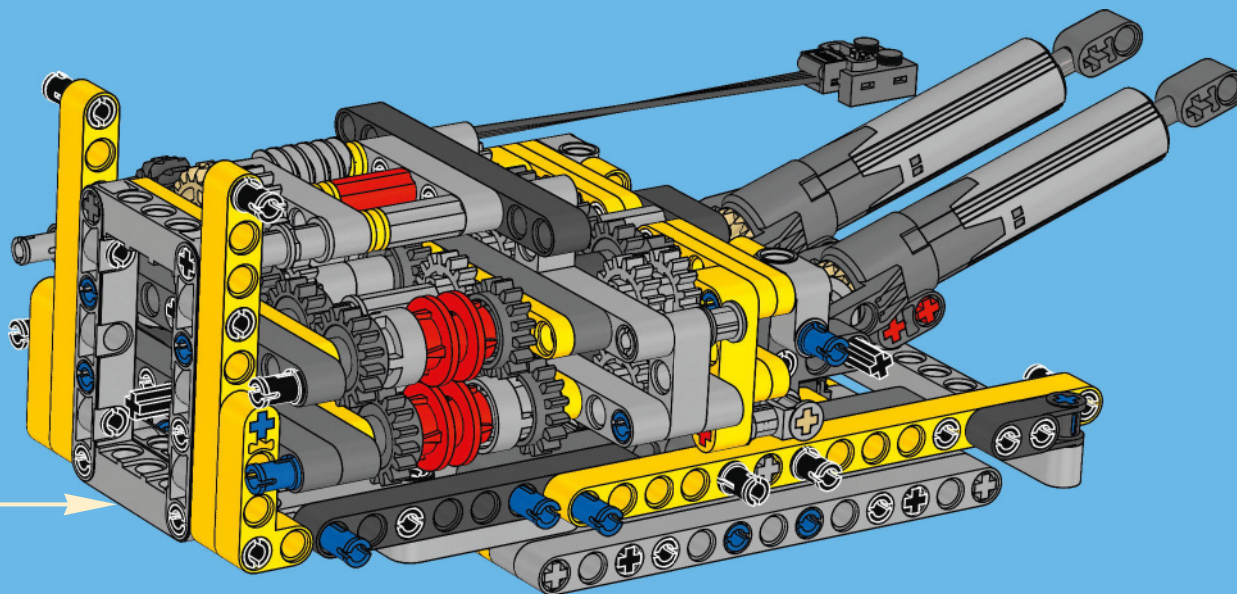

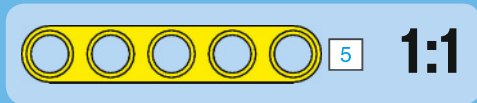

# 82

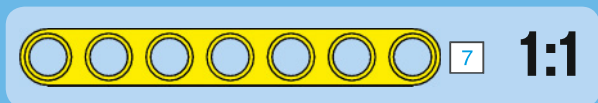
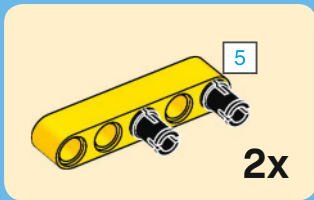
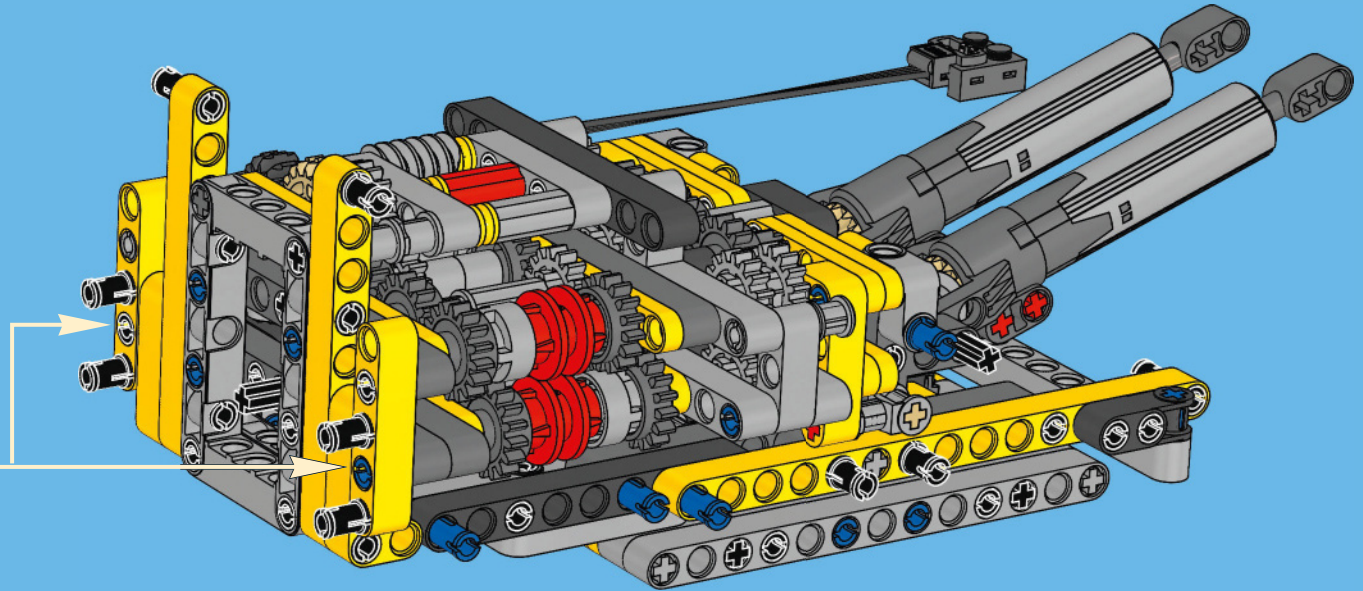

# 83

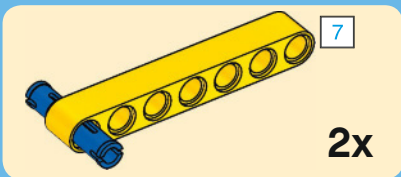
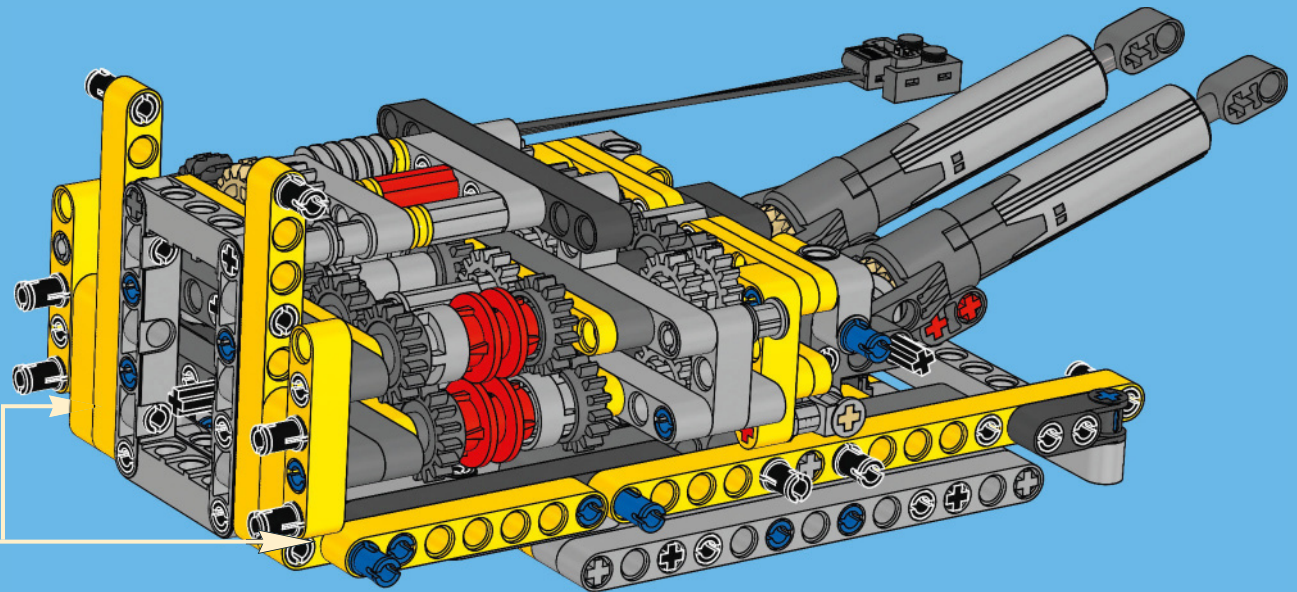



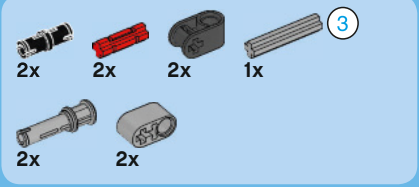

84

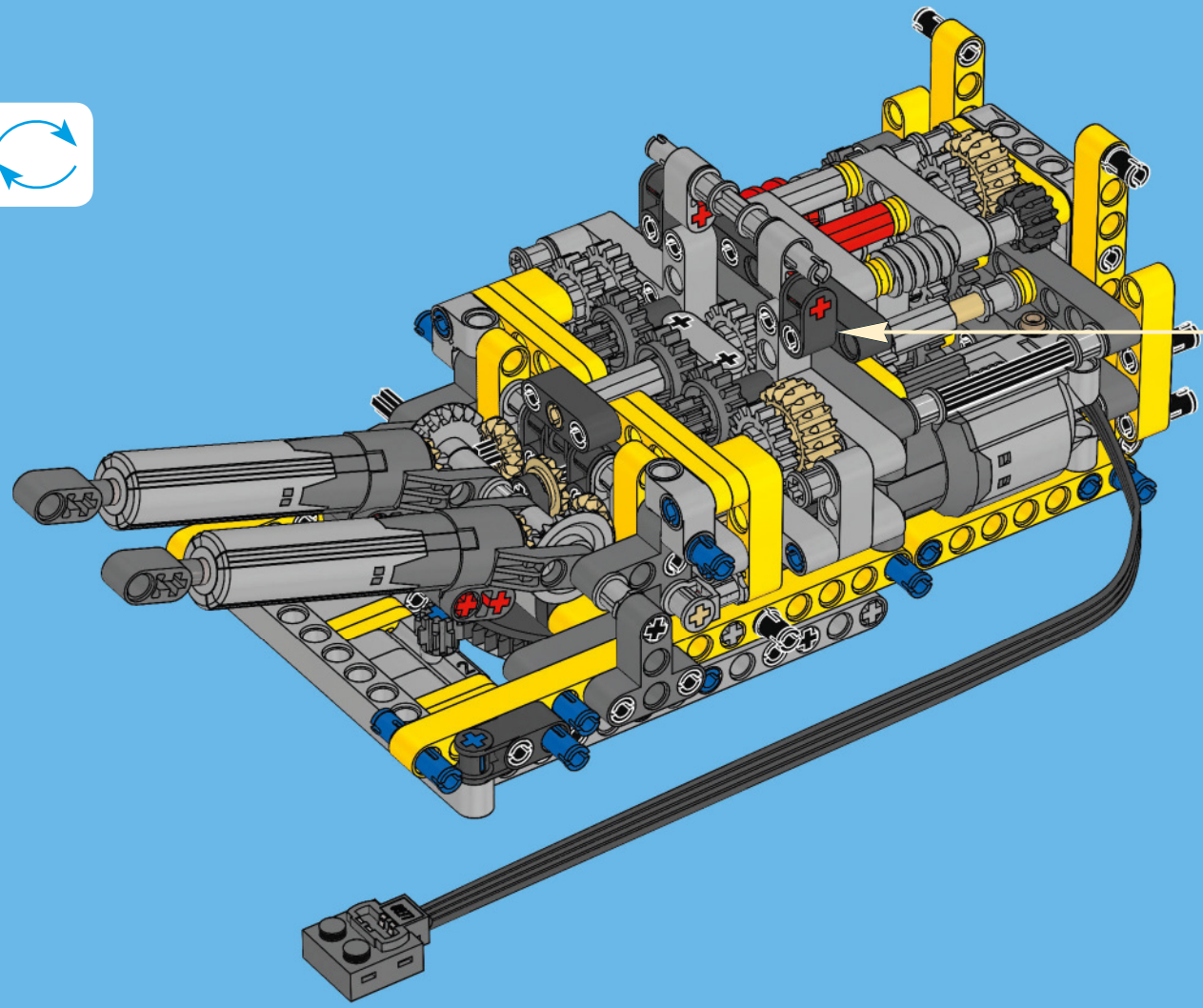
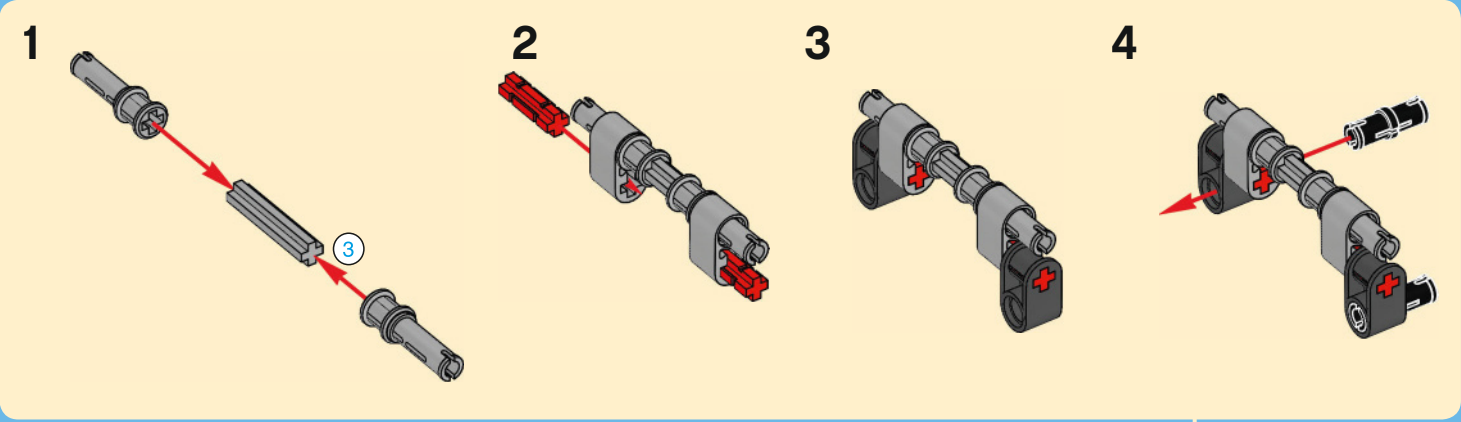

2x

2x

# 85

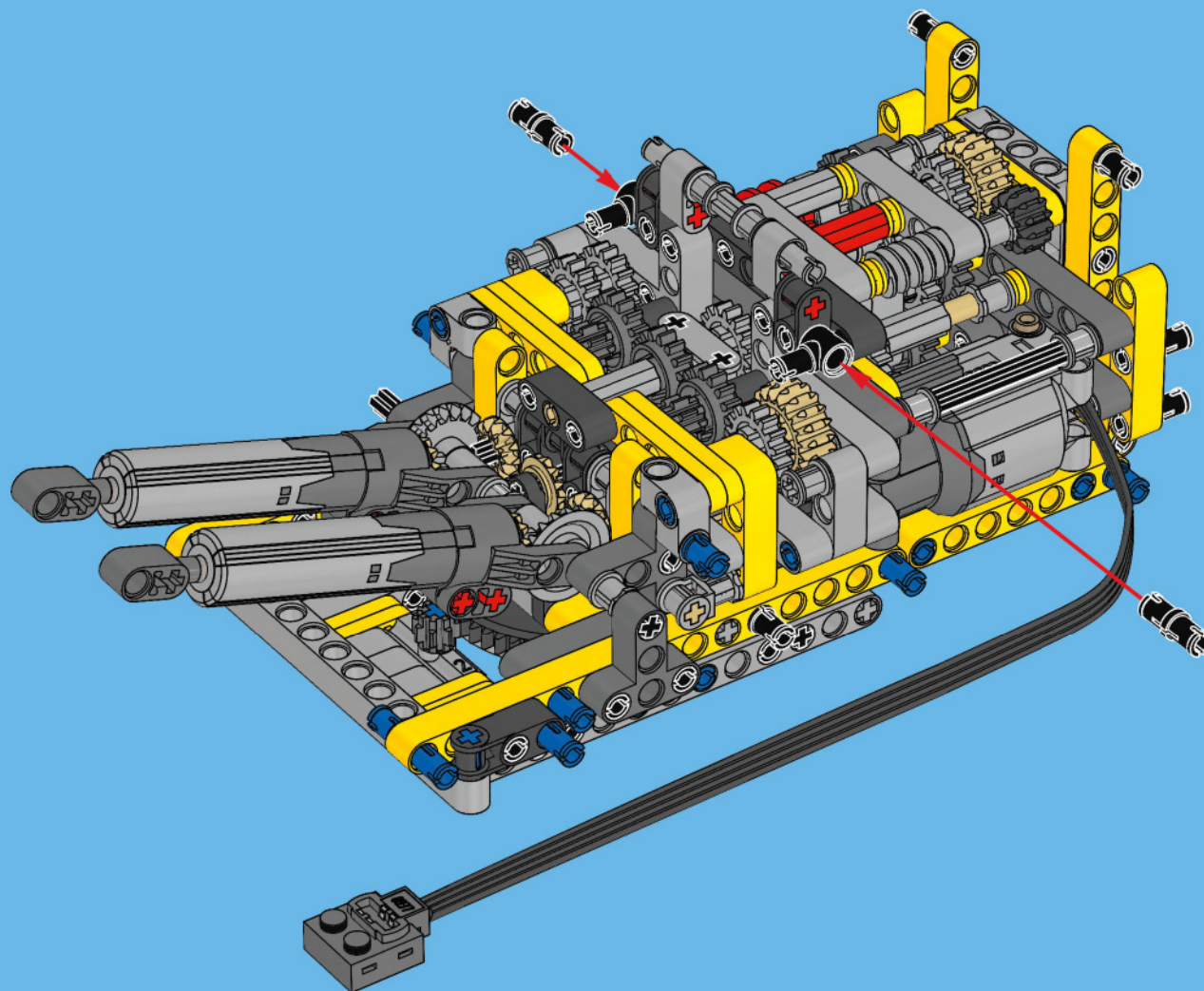



# 86

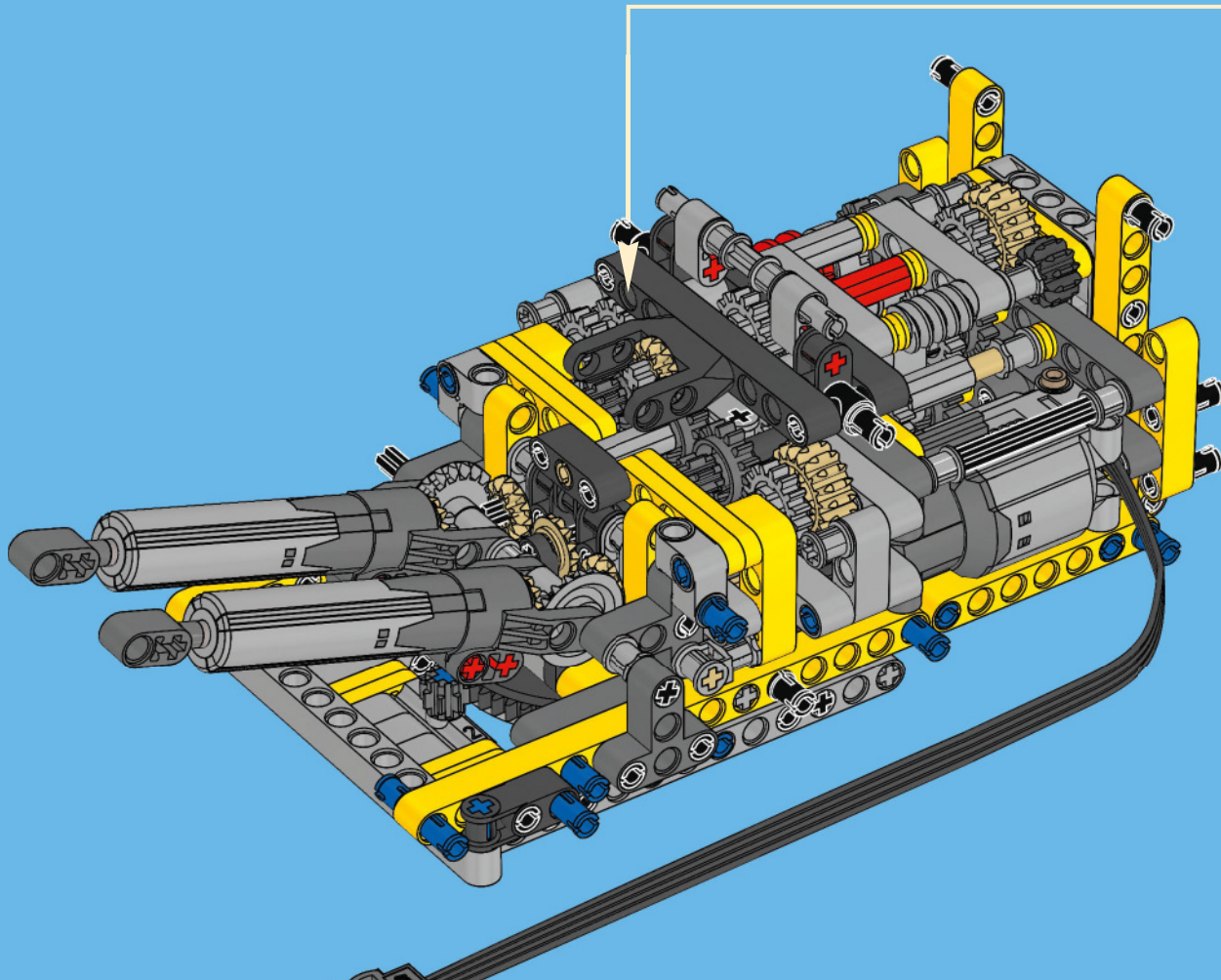
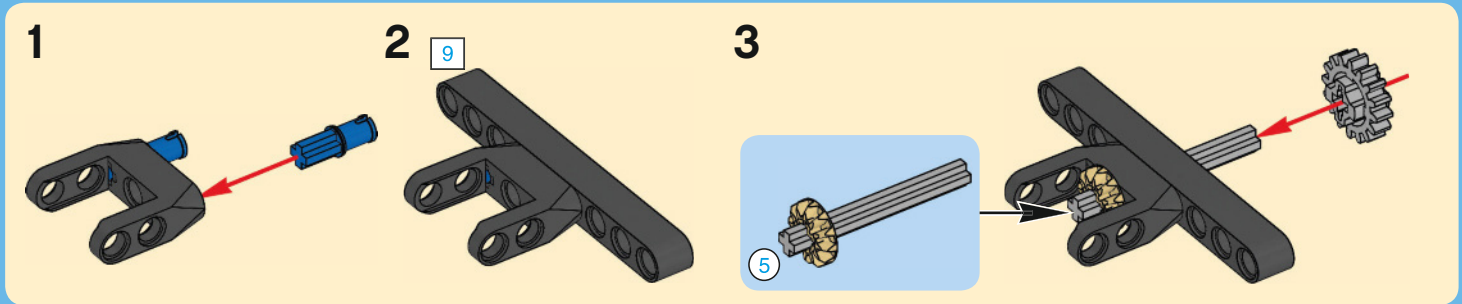
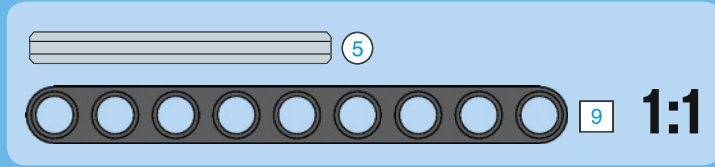
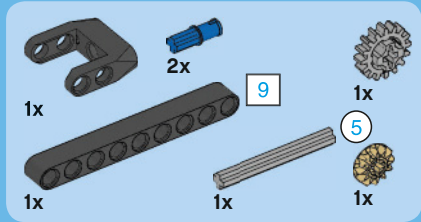

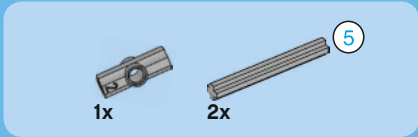
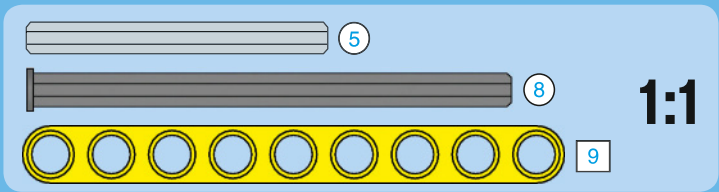
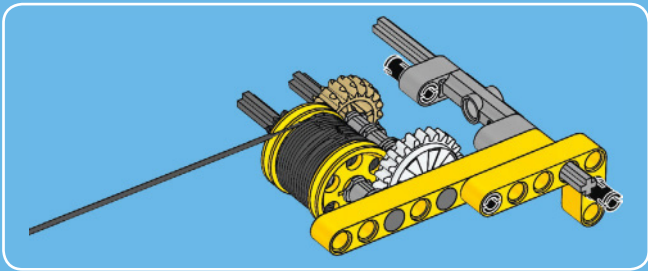

1

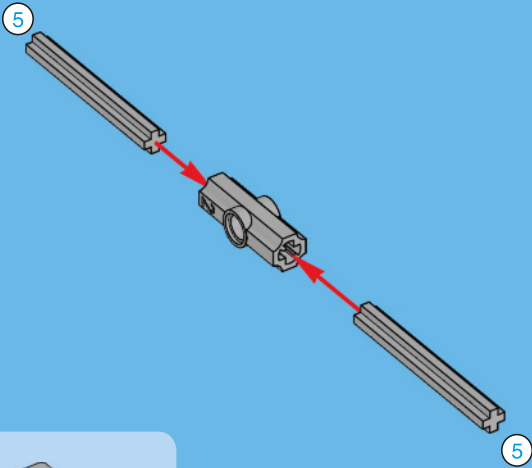

2

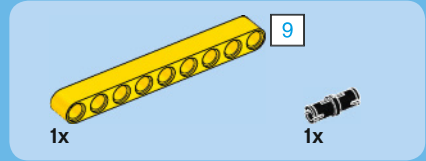
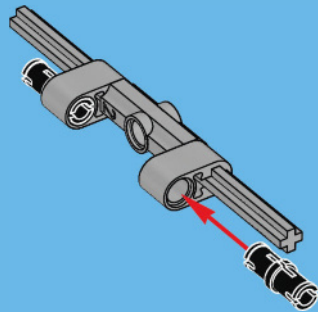

3

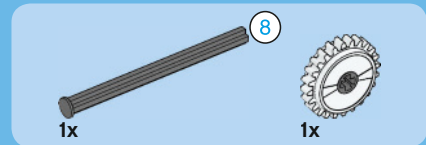
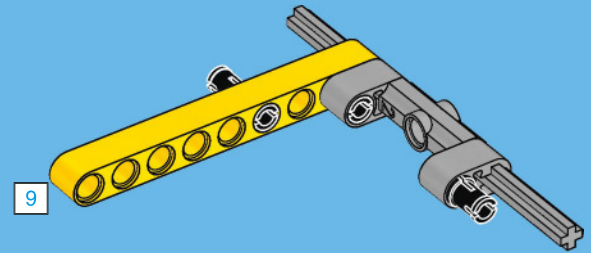

4

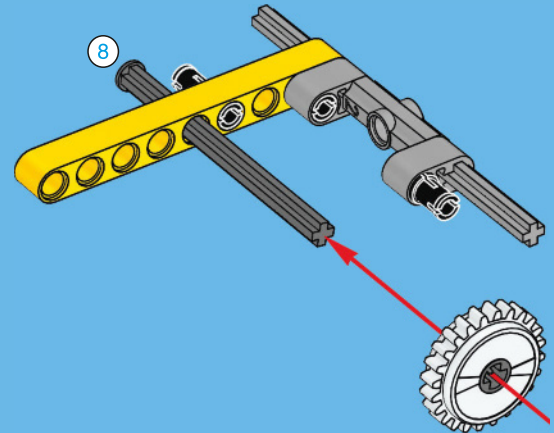



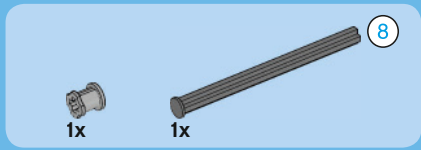

5

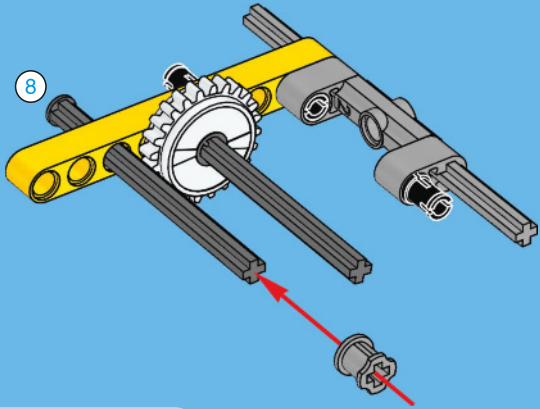

6

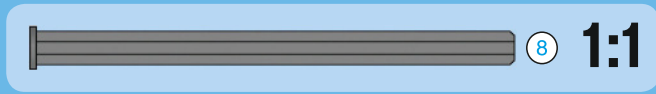
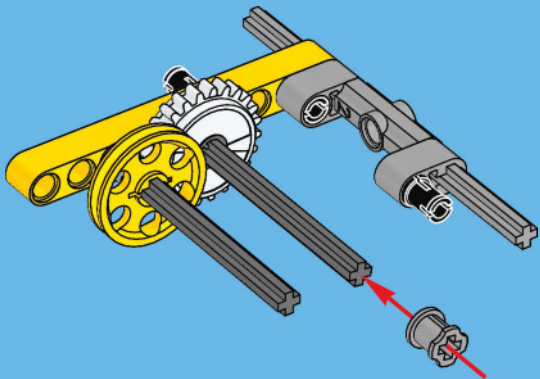

7

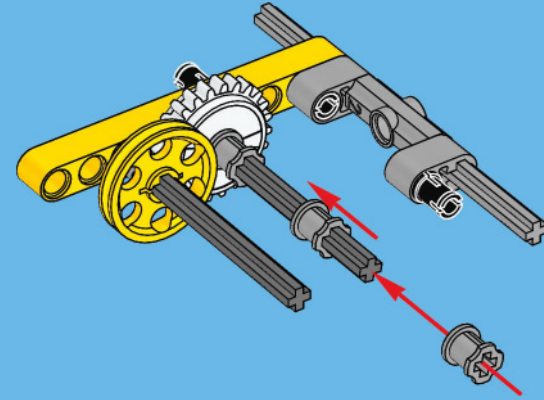
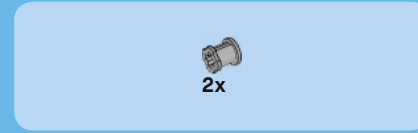

8

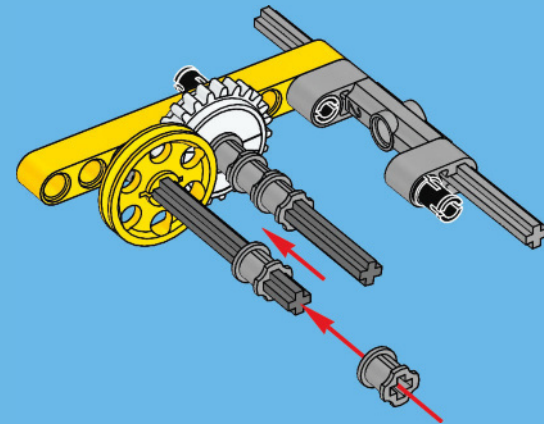



1x



1x

# 9

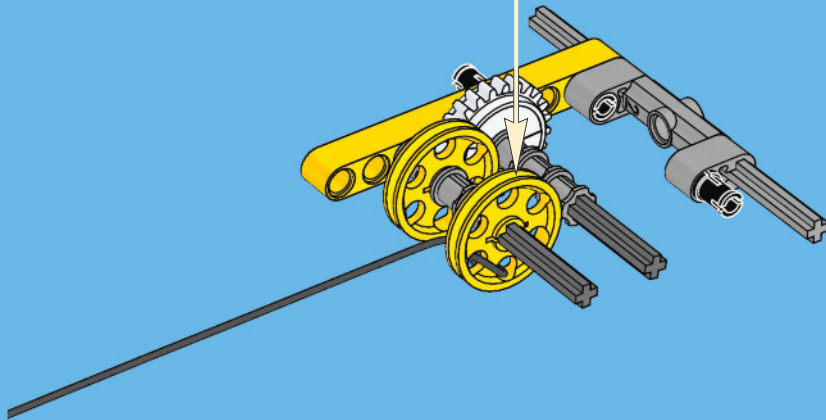
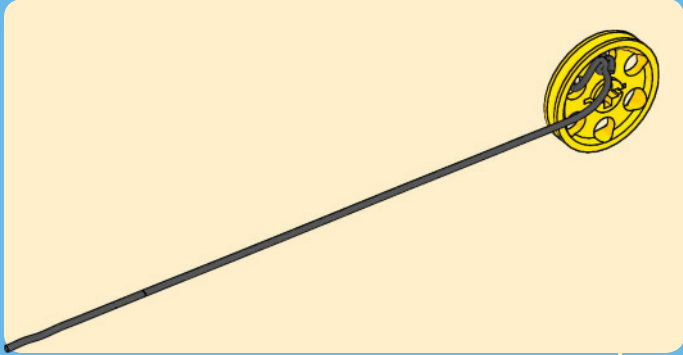

1x



1x

# 10

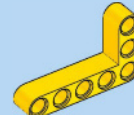
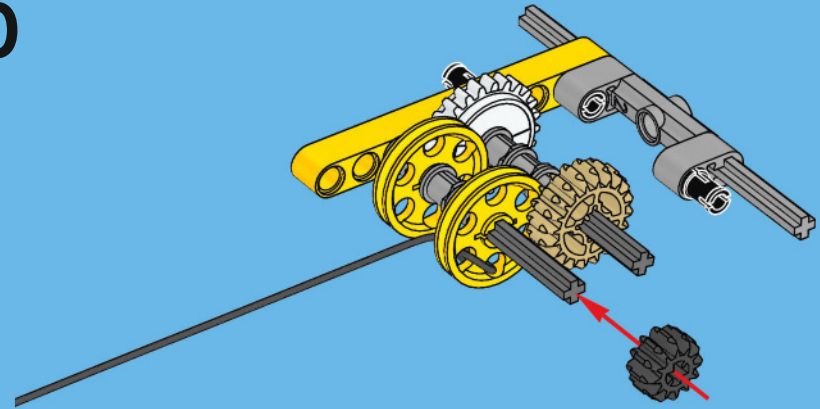

1x



1x

# 11

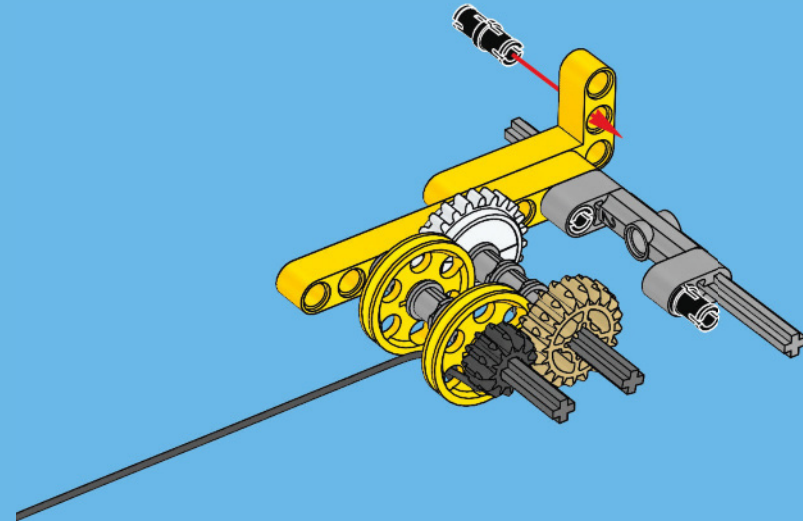



12

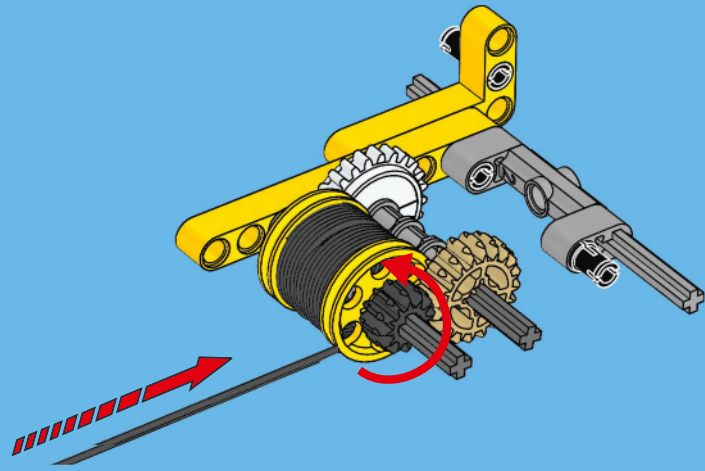

13

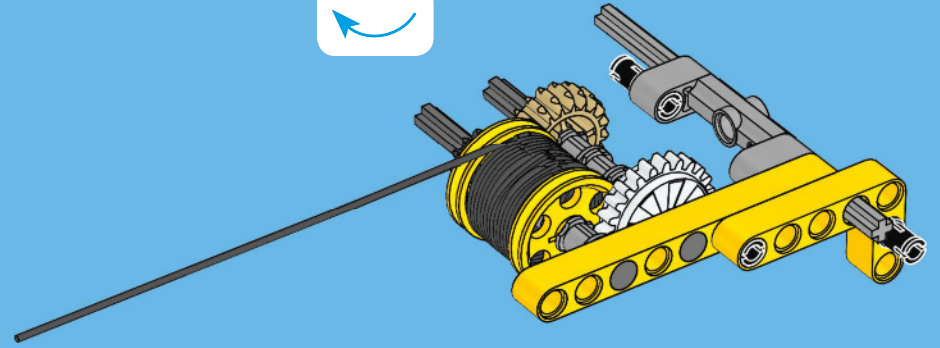

87

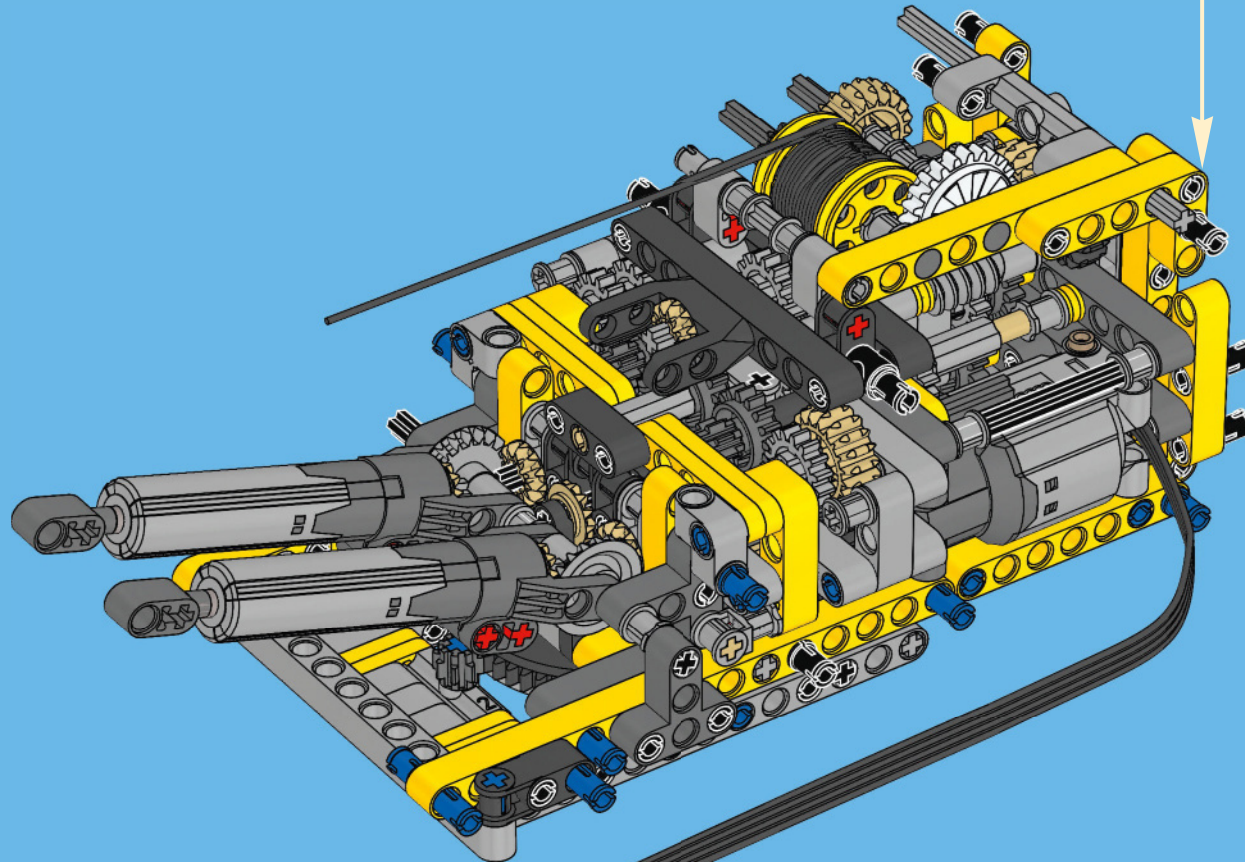

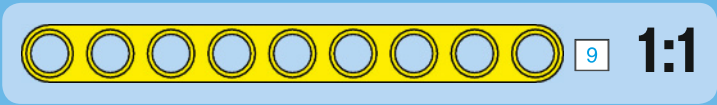
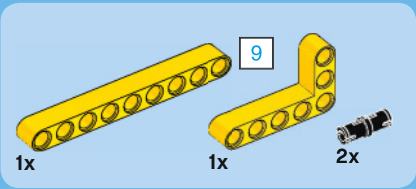

88

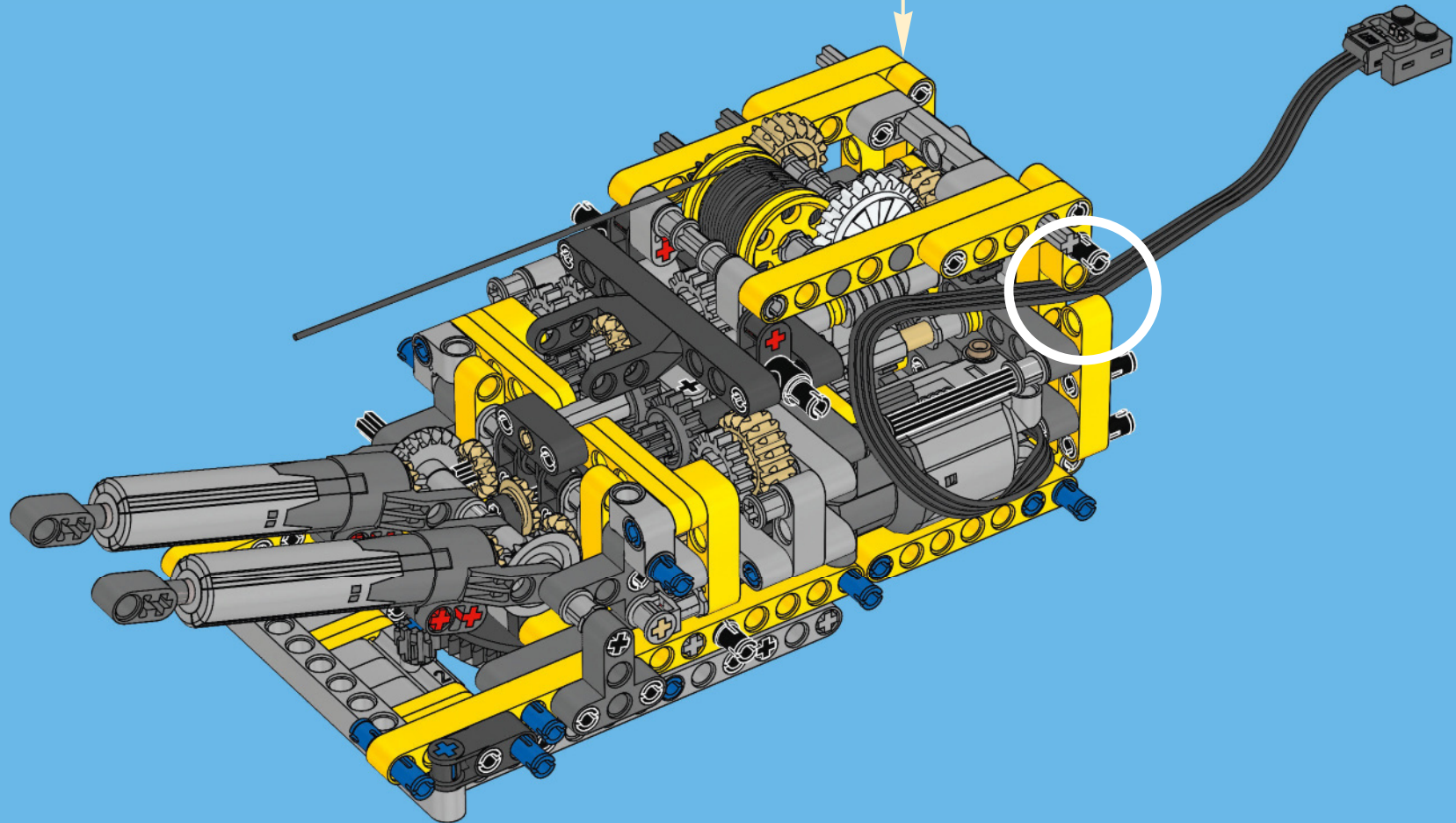
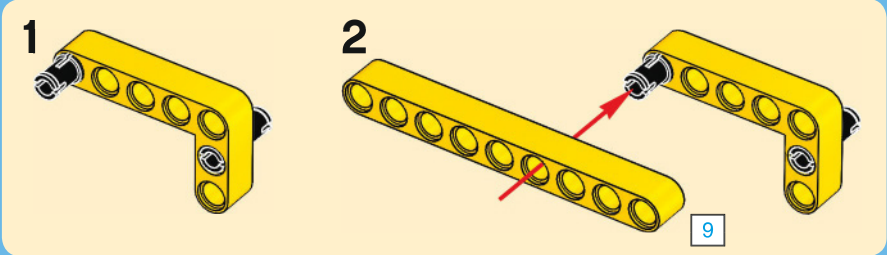



2x

89

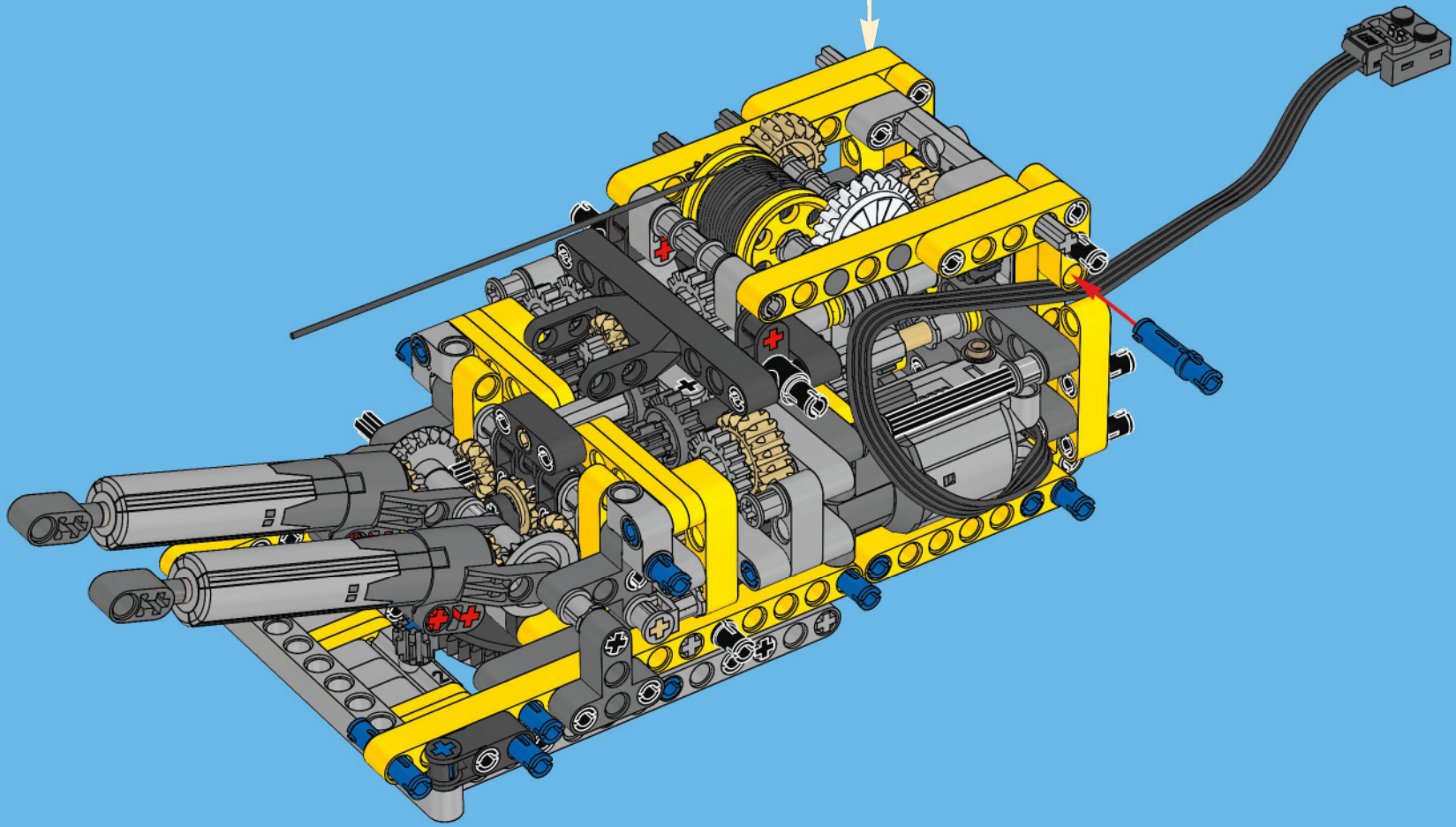

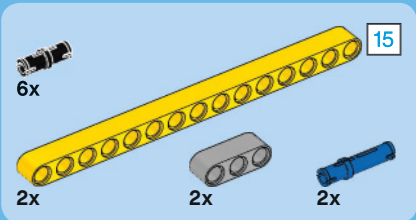

# 90

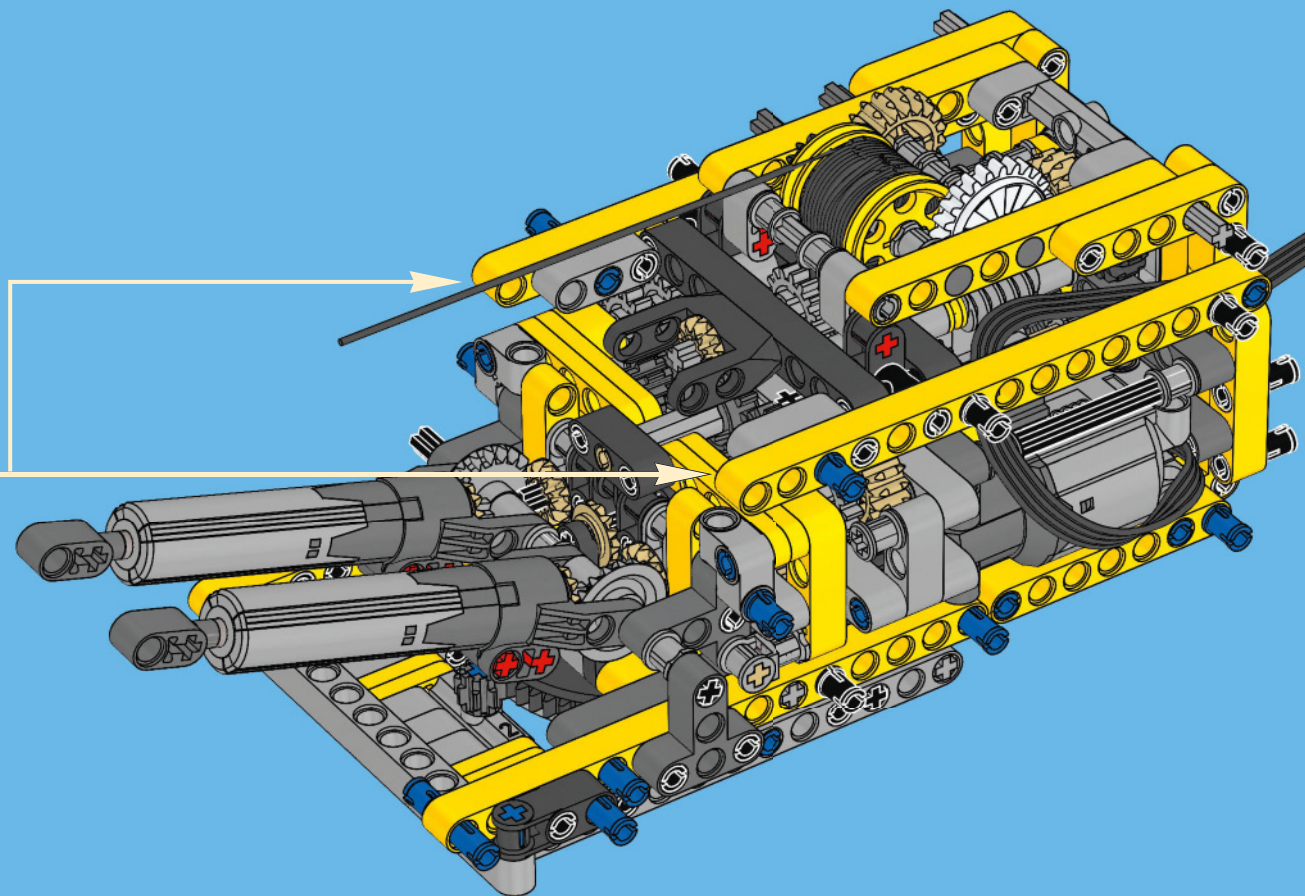
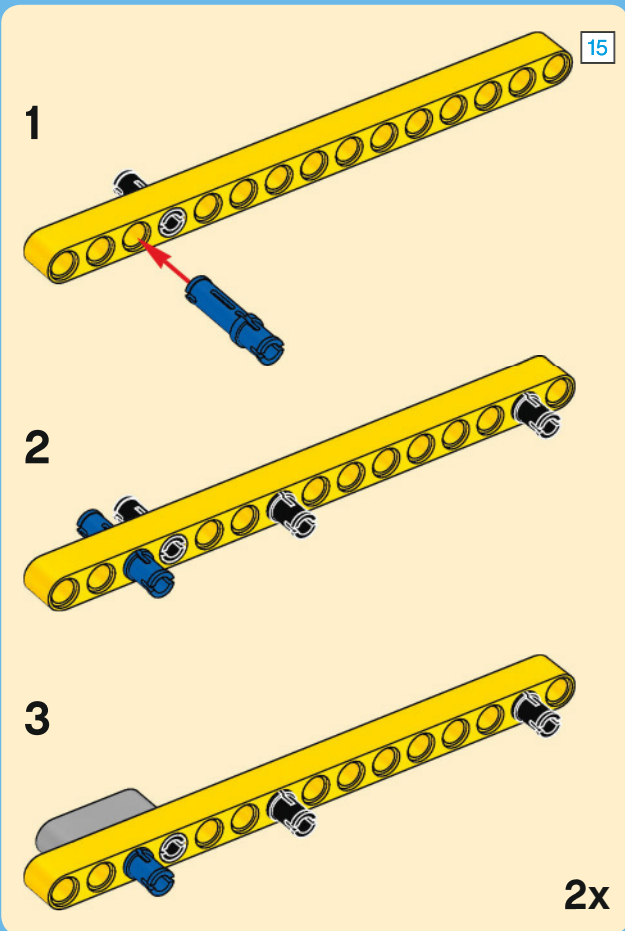



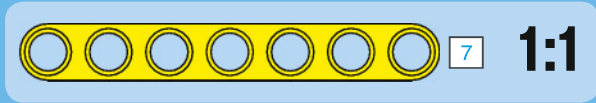
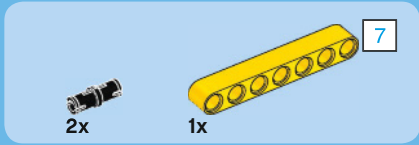

91

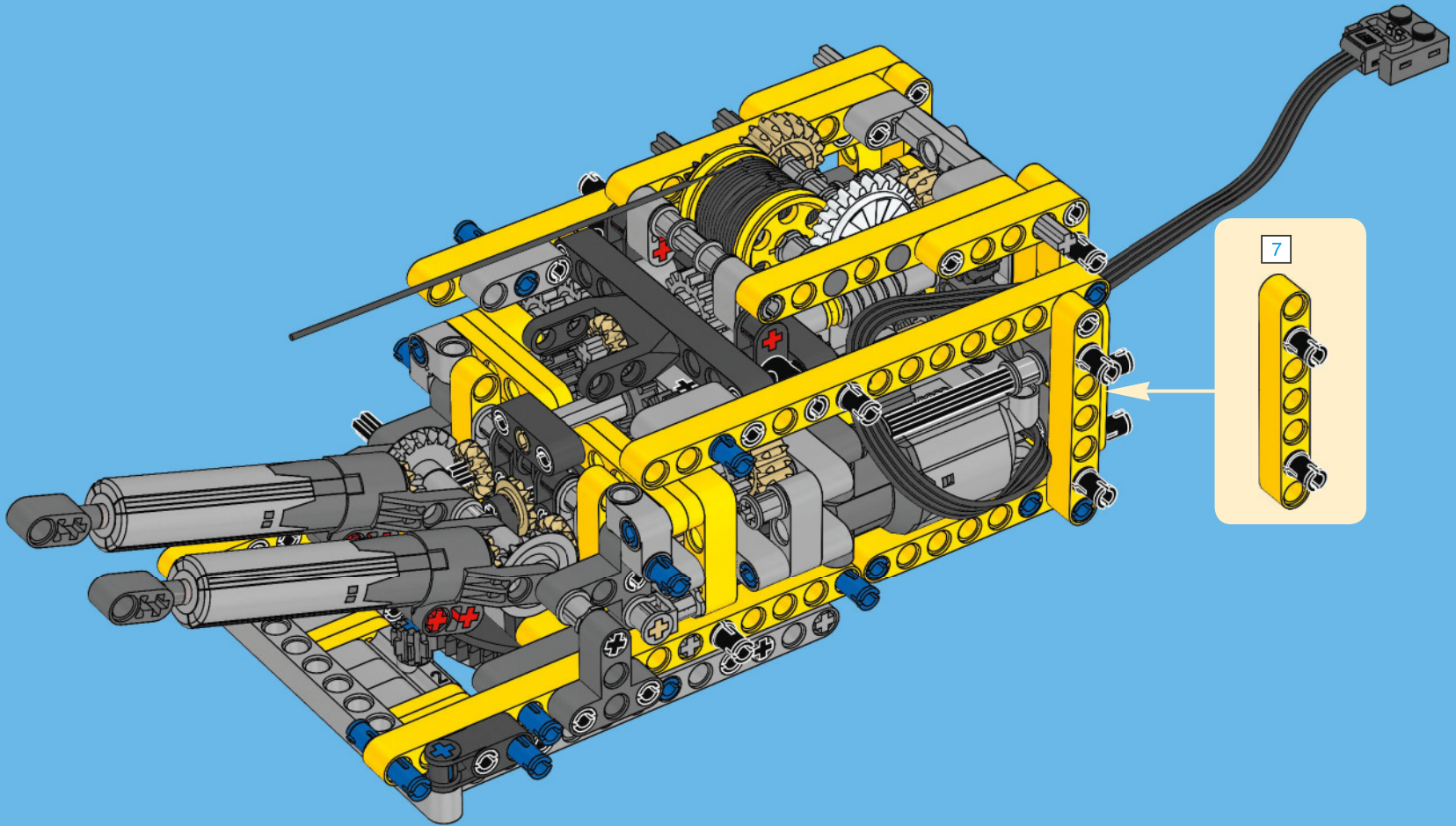

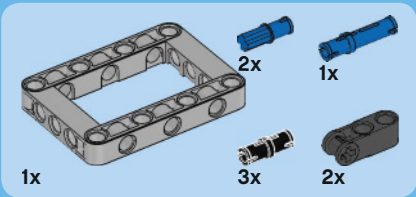

92

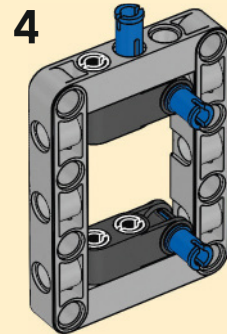
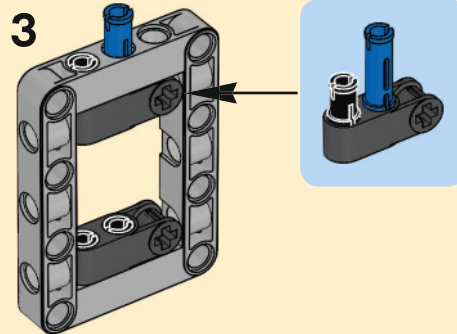
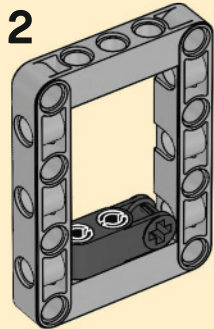
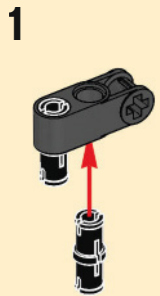
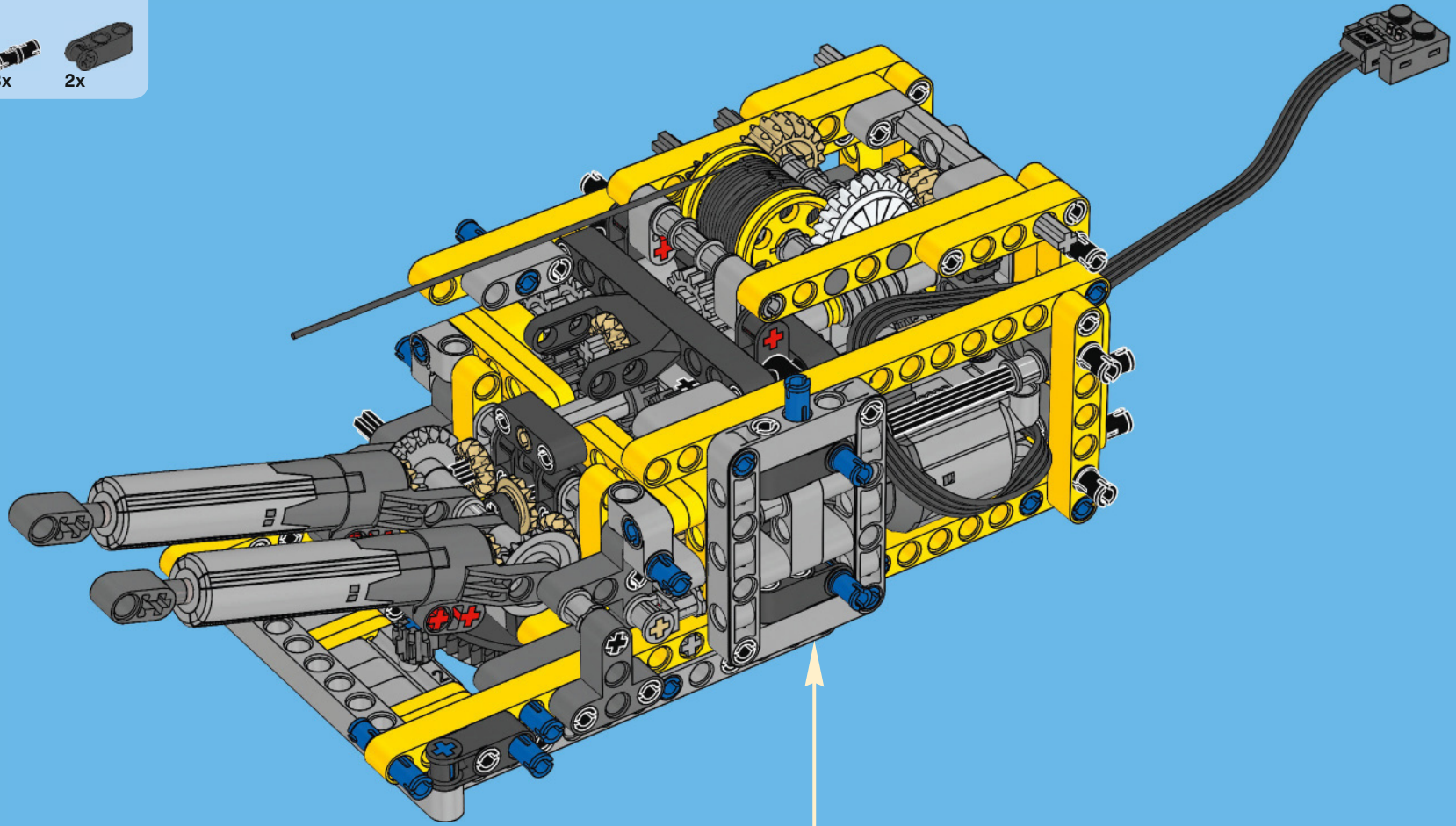



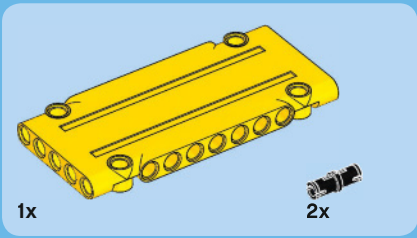

93

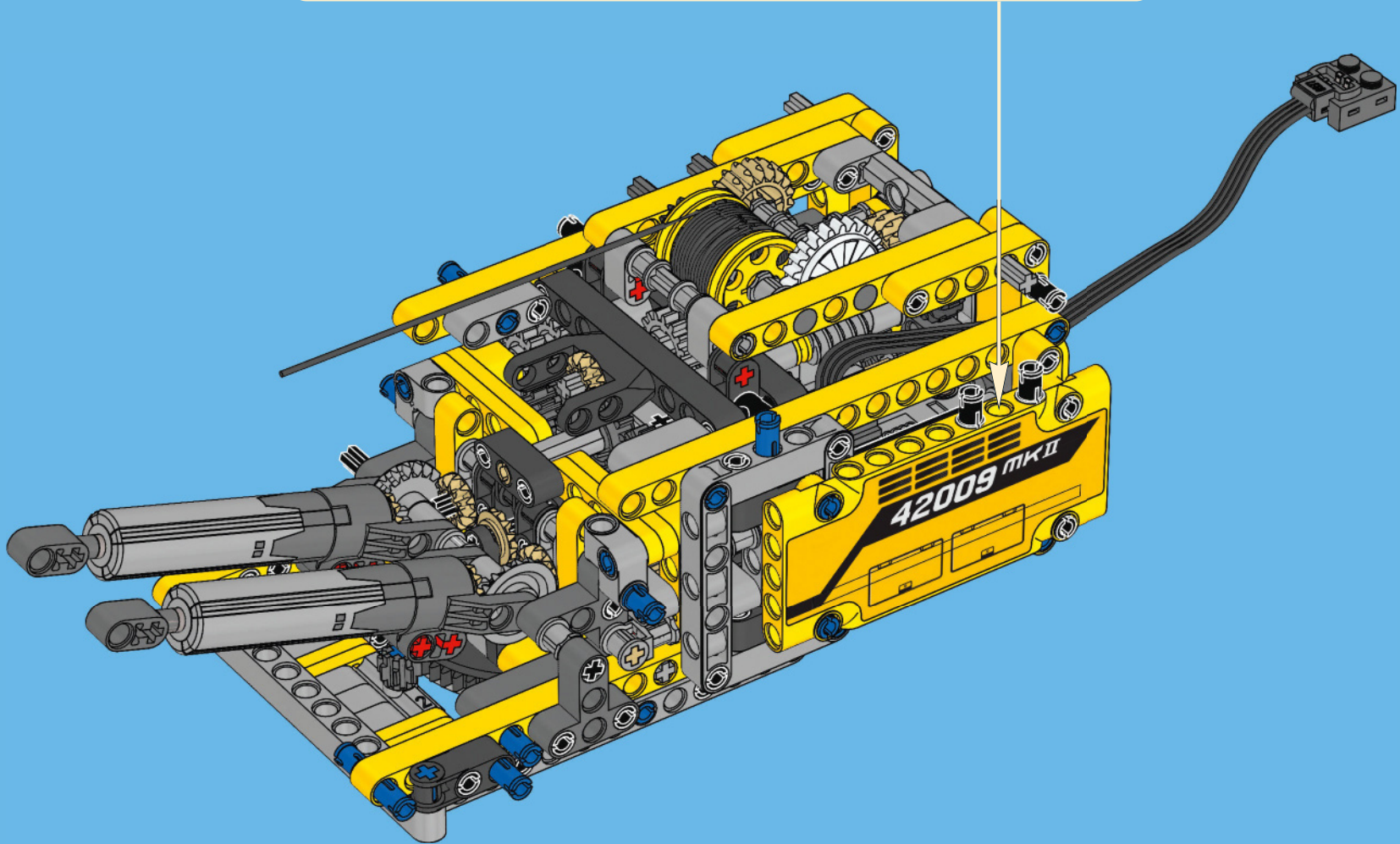
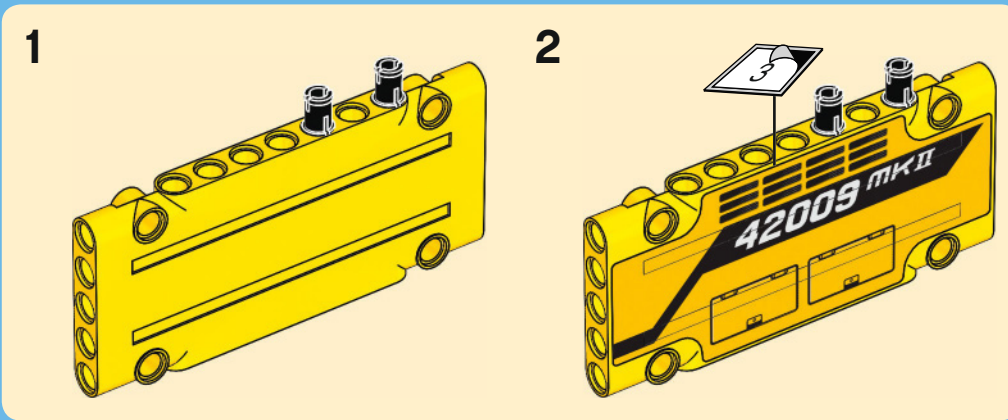



2x



2x

# 94

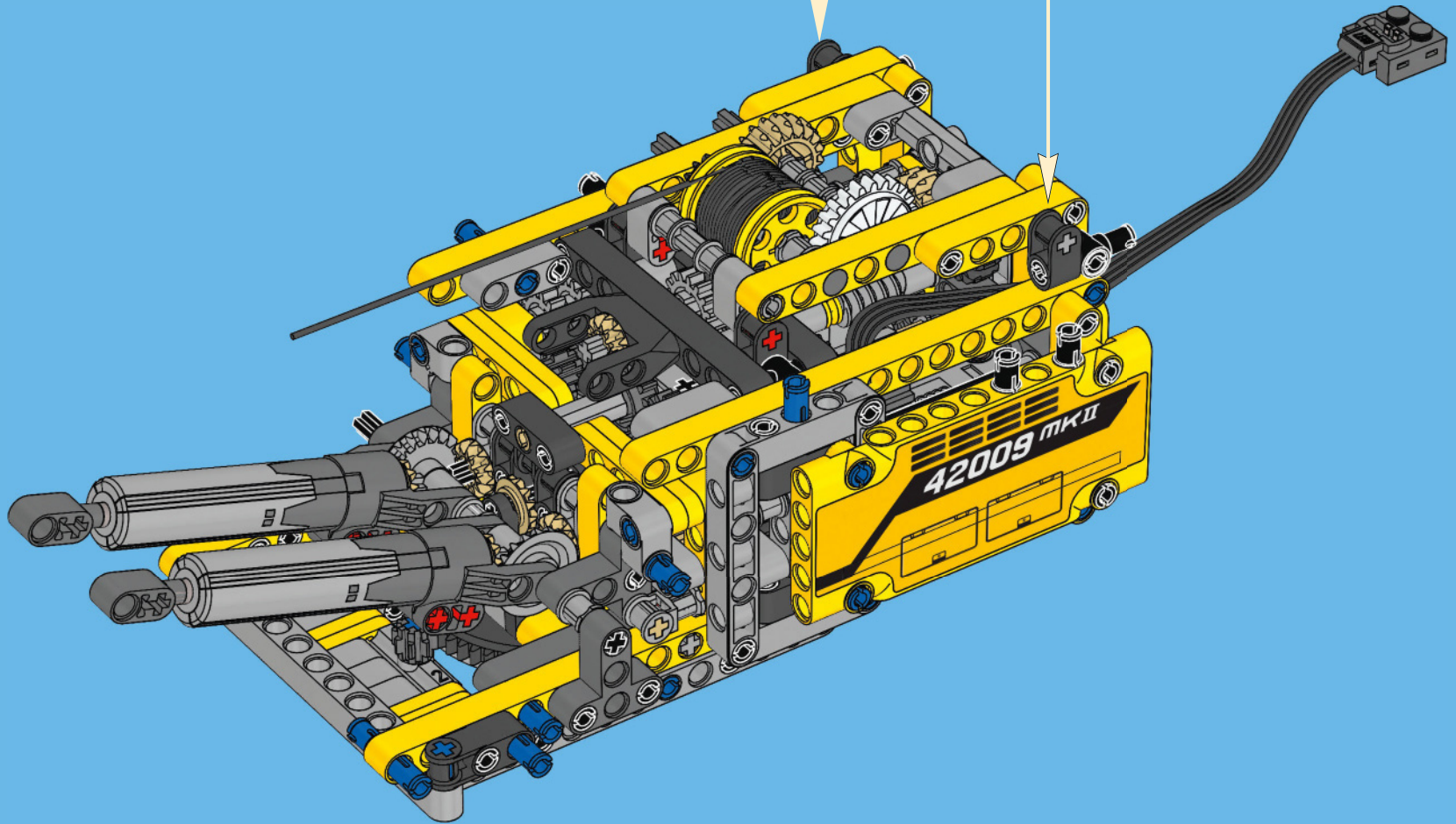
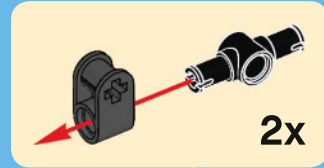



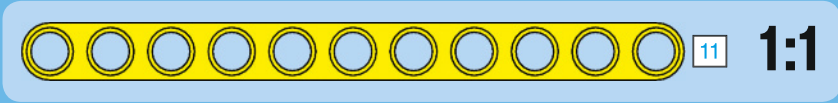
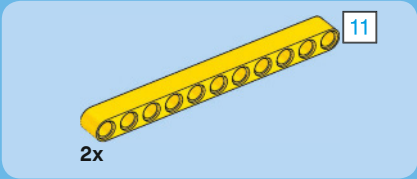

95

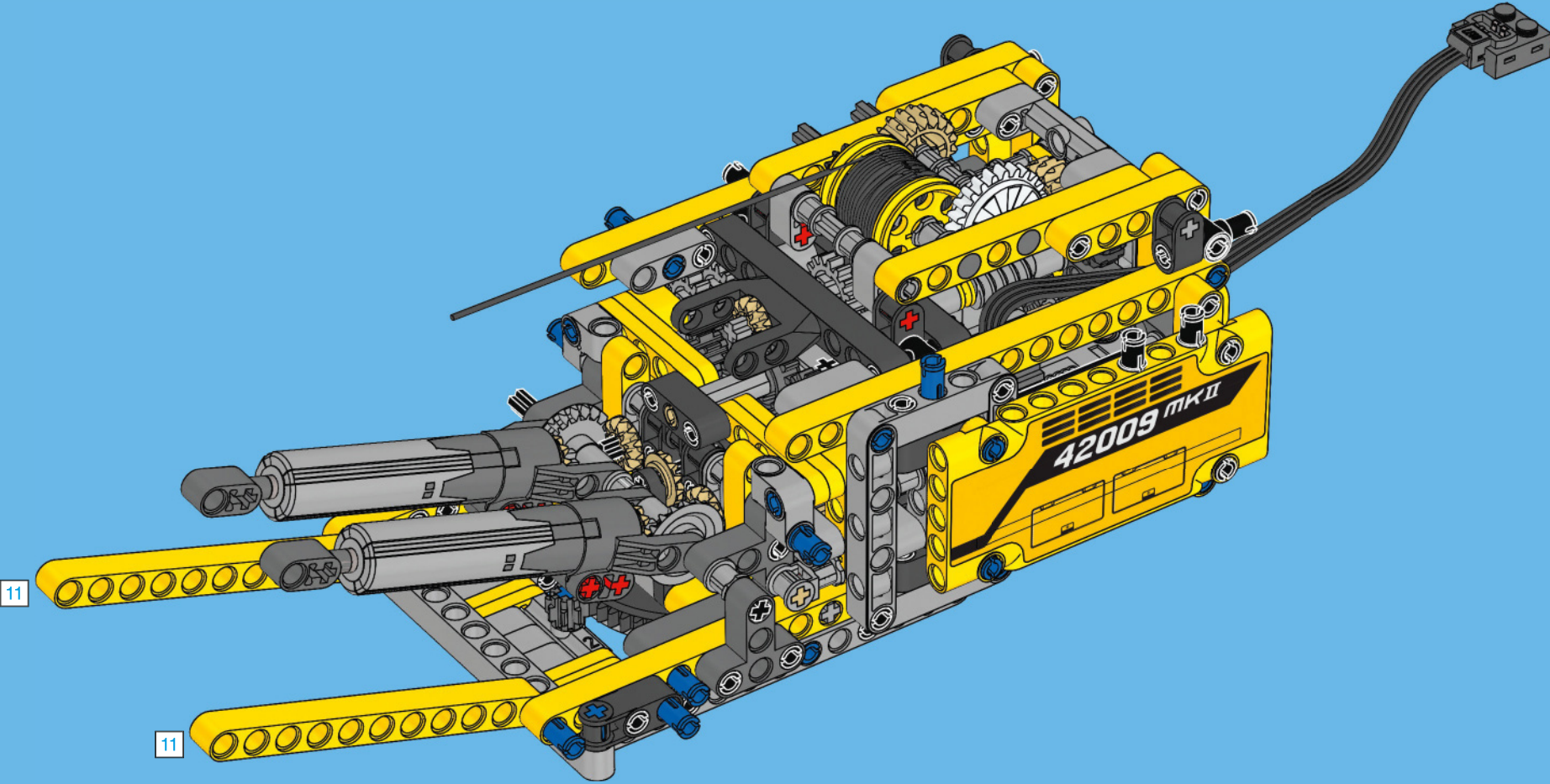

96

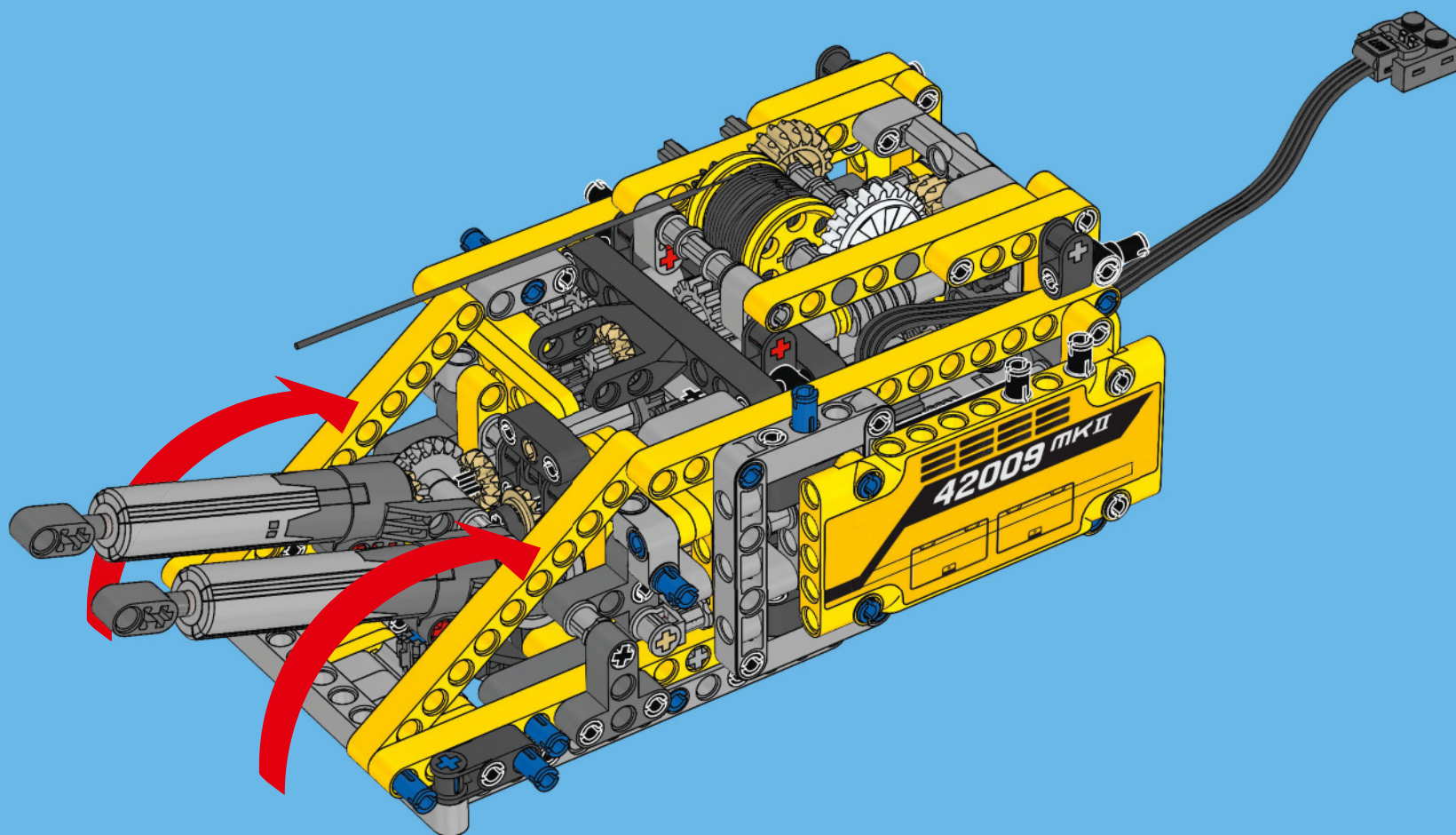





2x

97

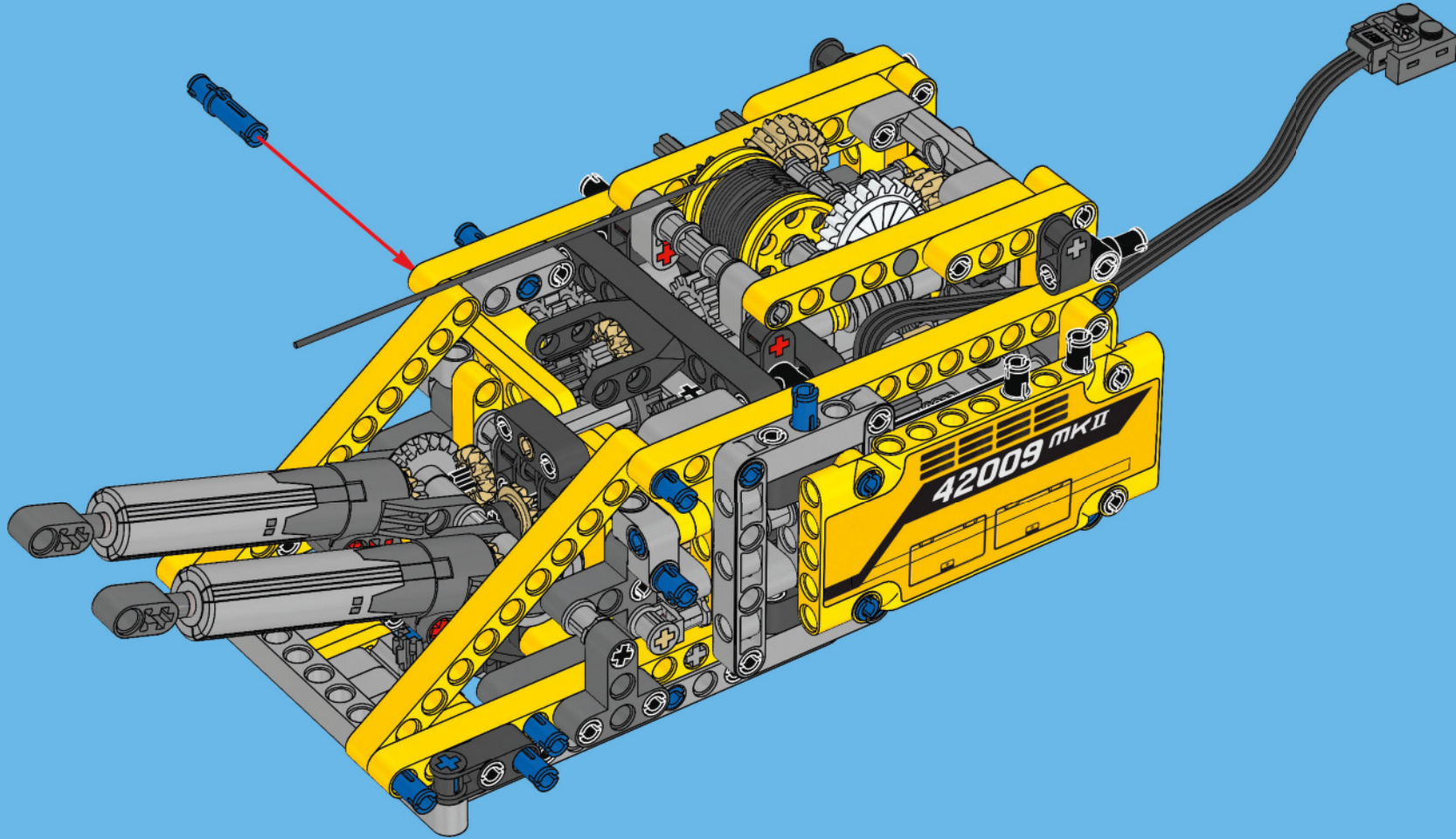

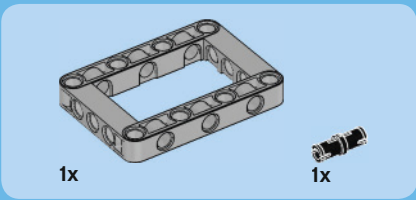

98

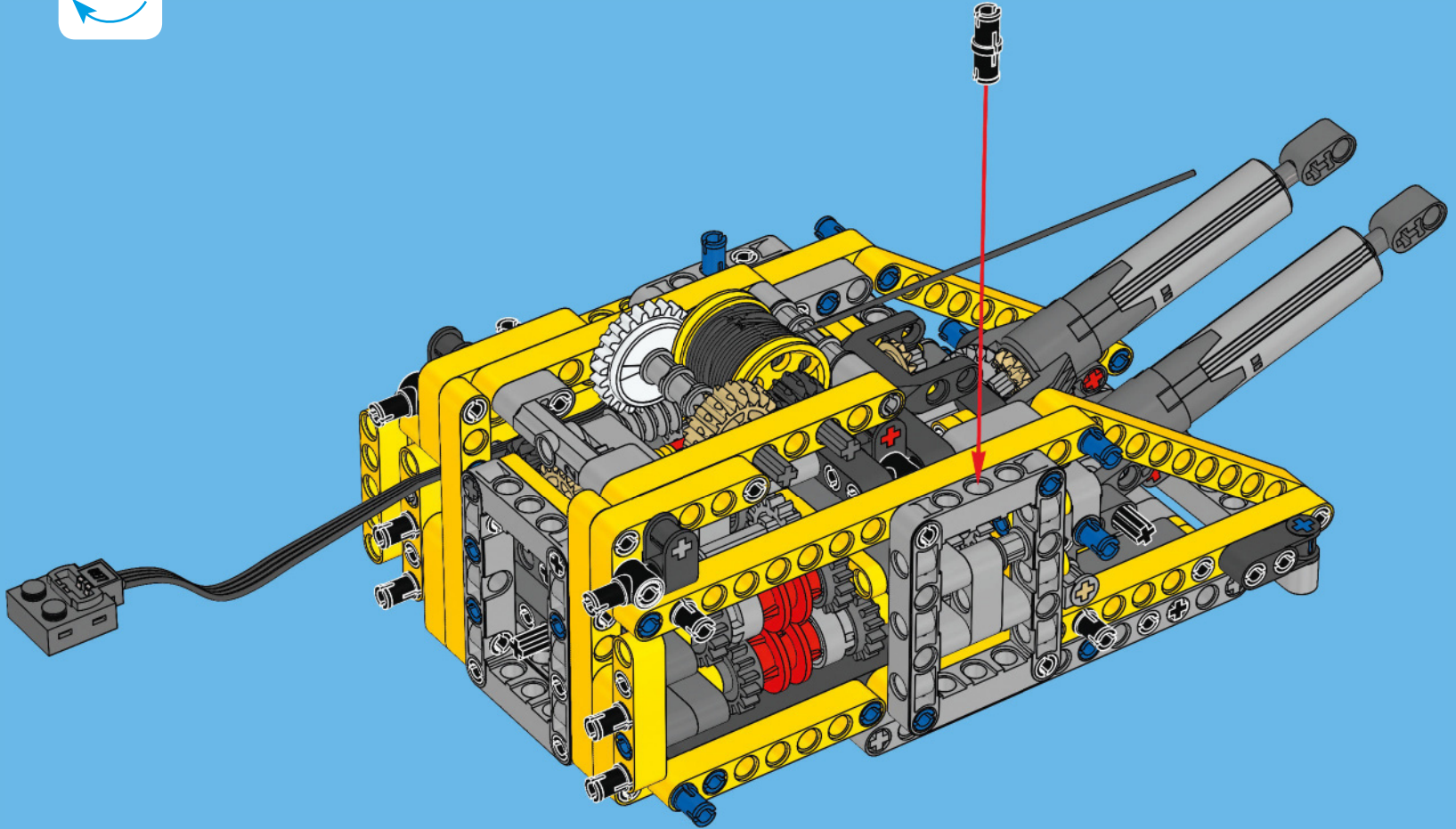



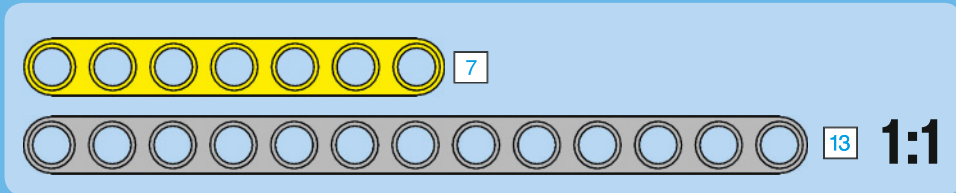
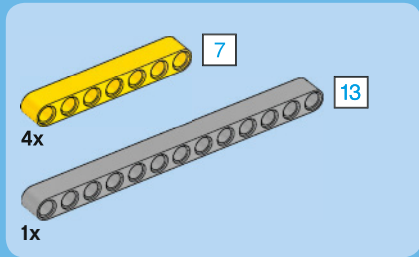

99

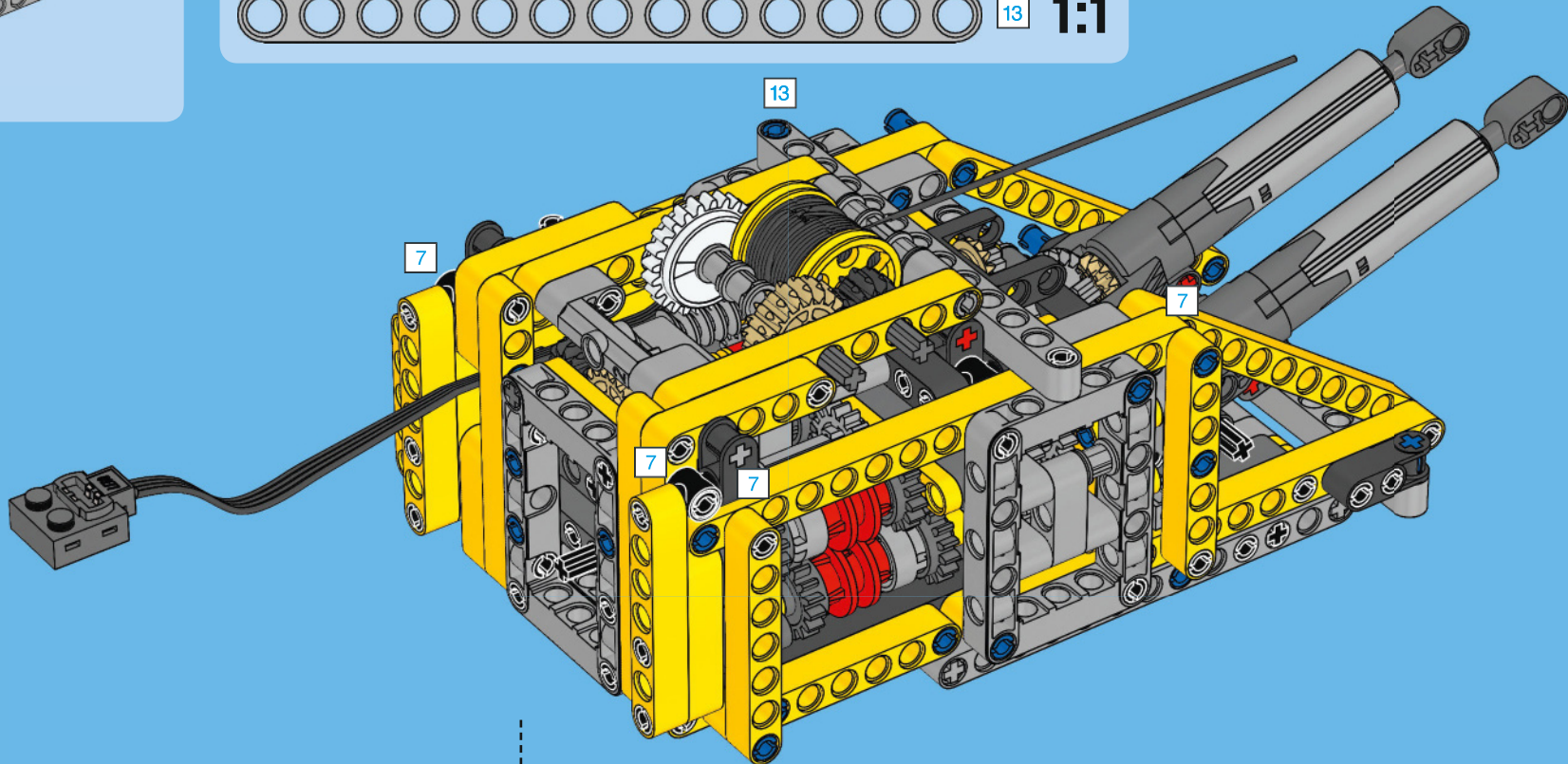

100

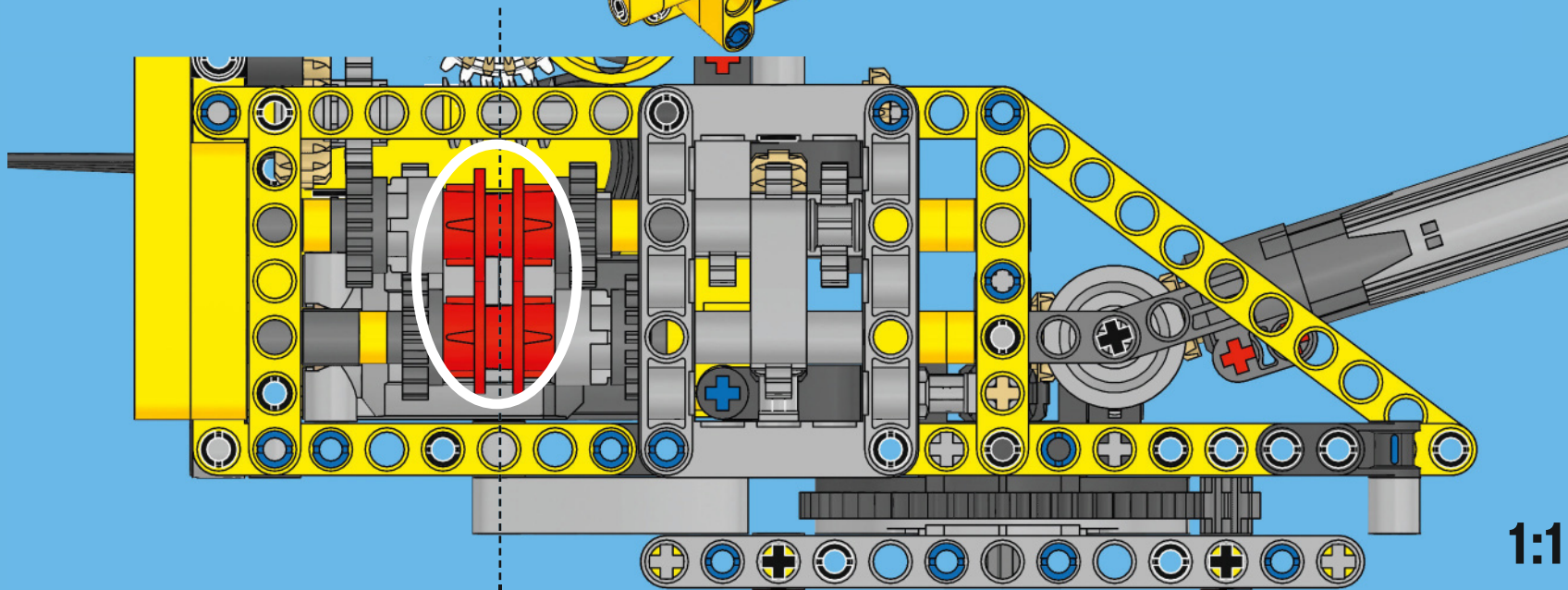

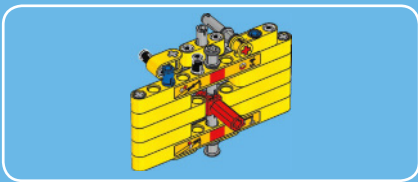

5

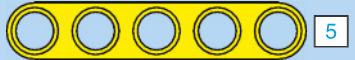

5



11

1:1

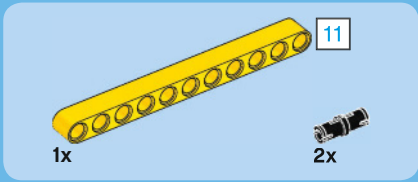

1x

2x

1

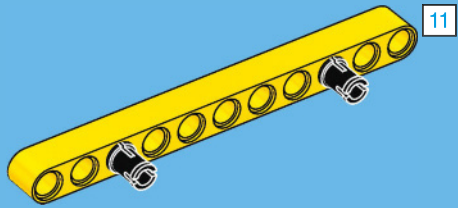

11

3



1x

2x

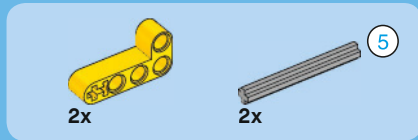
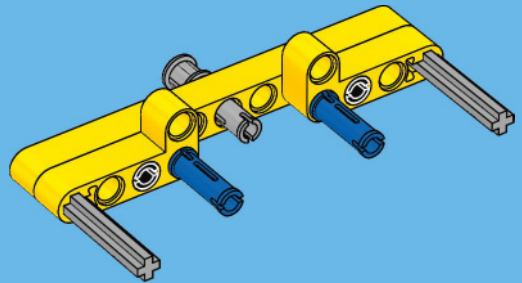

2x

2x

5

2

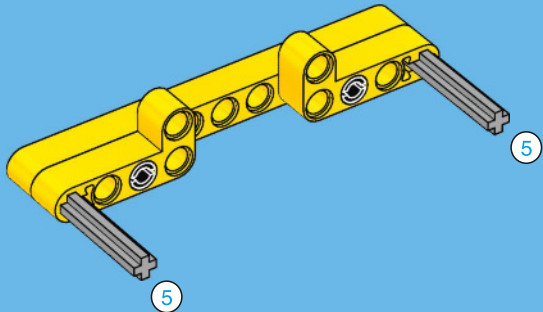

5

5

4



2x

5

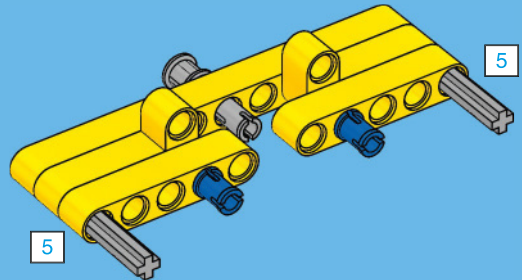

5

5



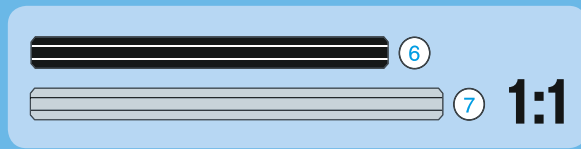
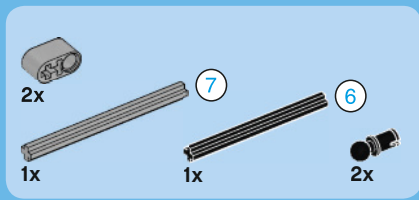

5

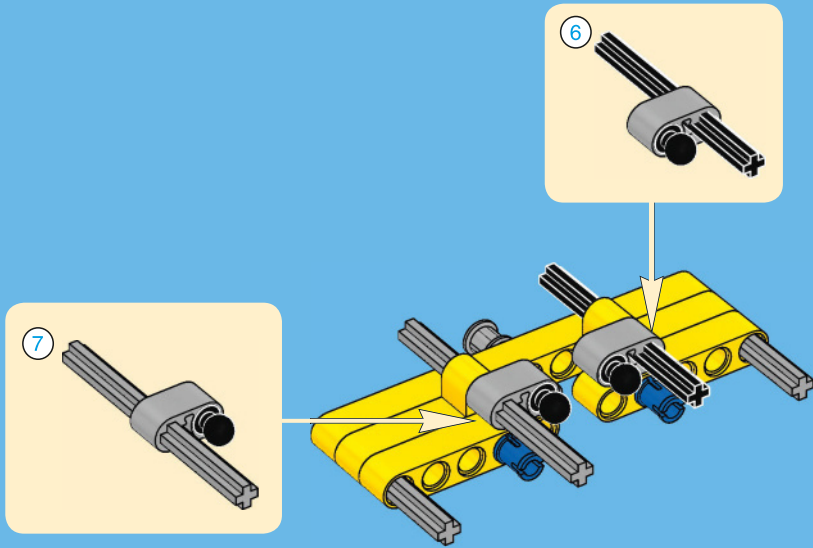

6

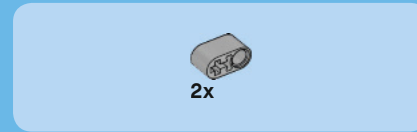
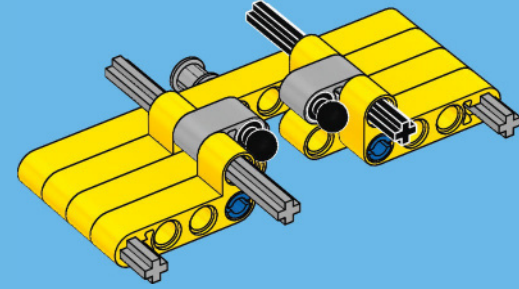

7

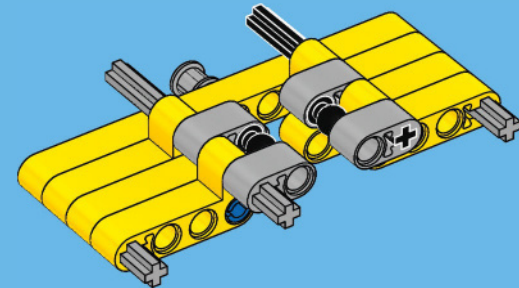

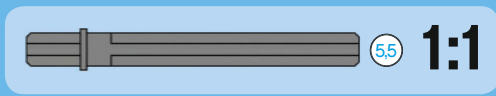
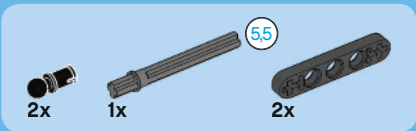

8

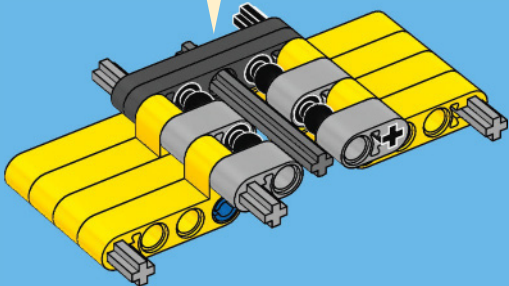
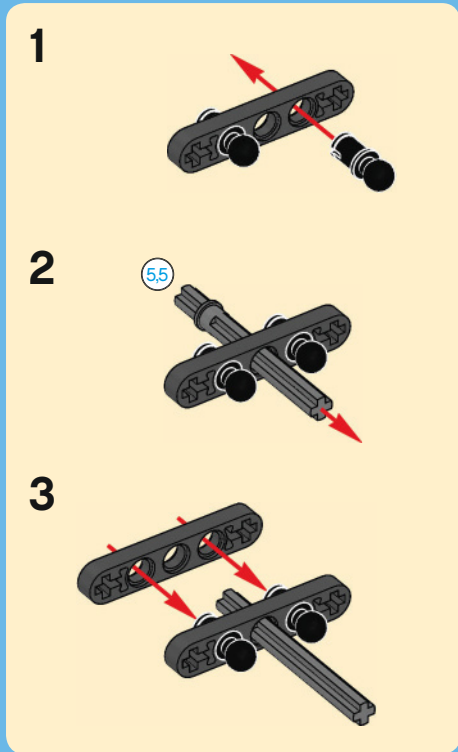

9

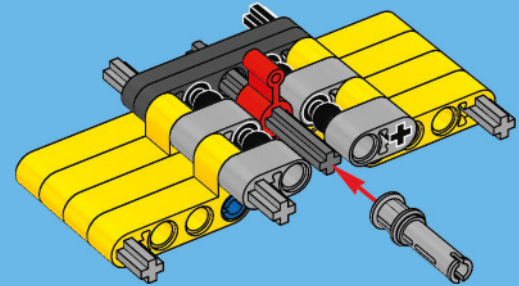

10

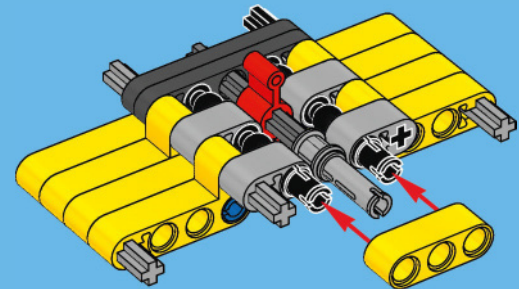





3x

# 11

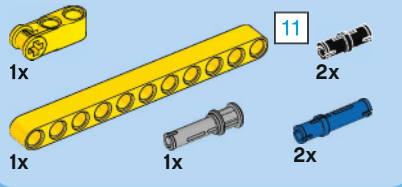
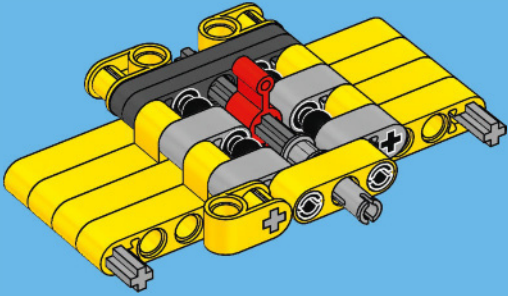

# 12

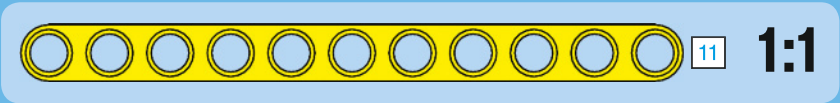
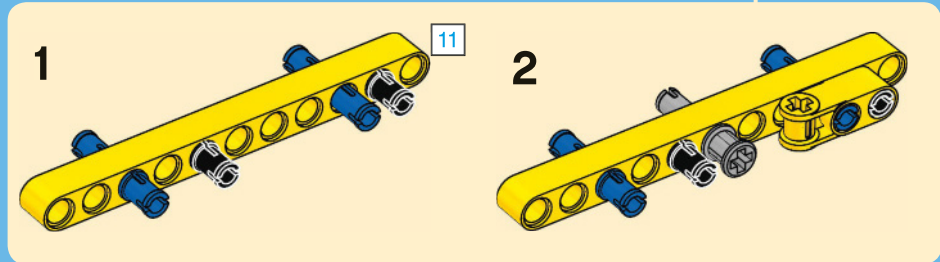
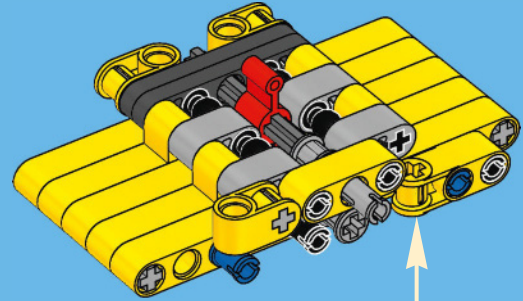



13

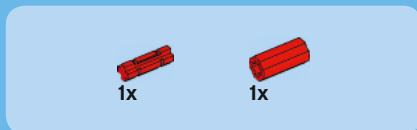
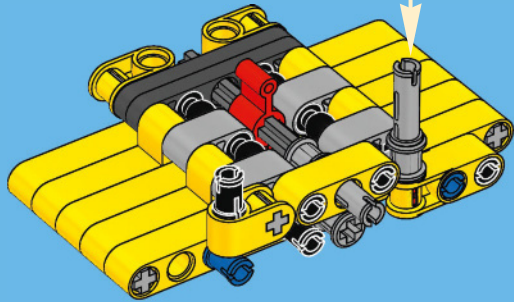
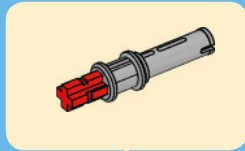

15

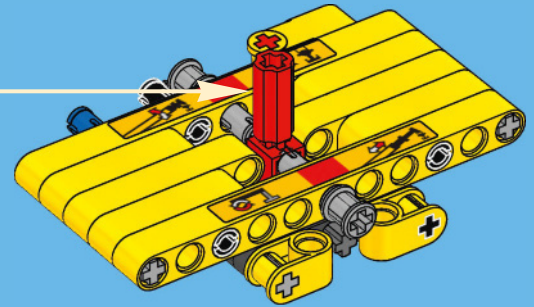
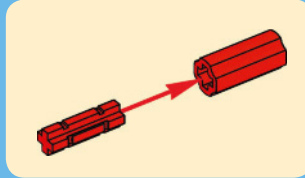

14

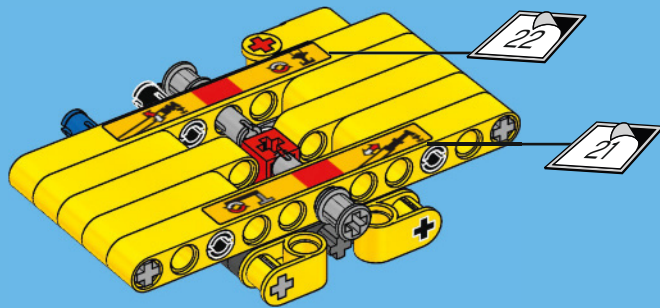

16

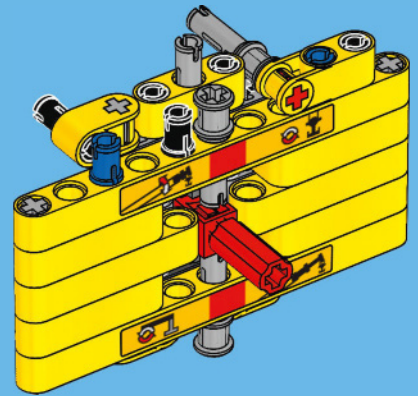



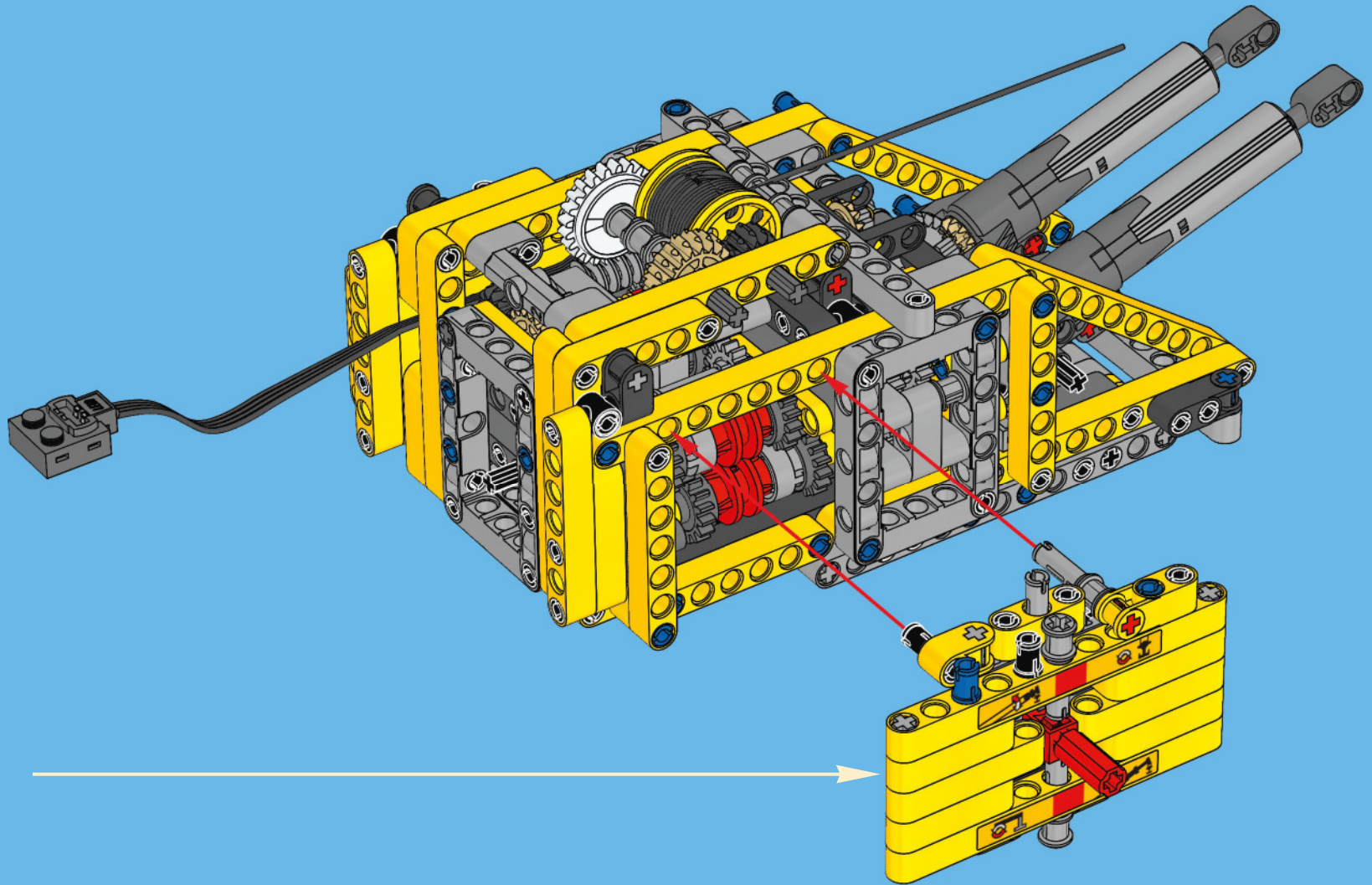

102

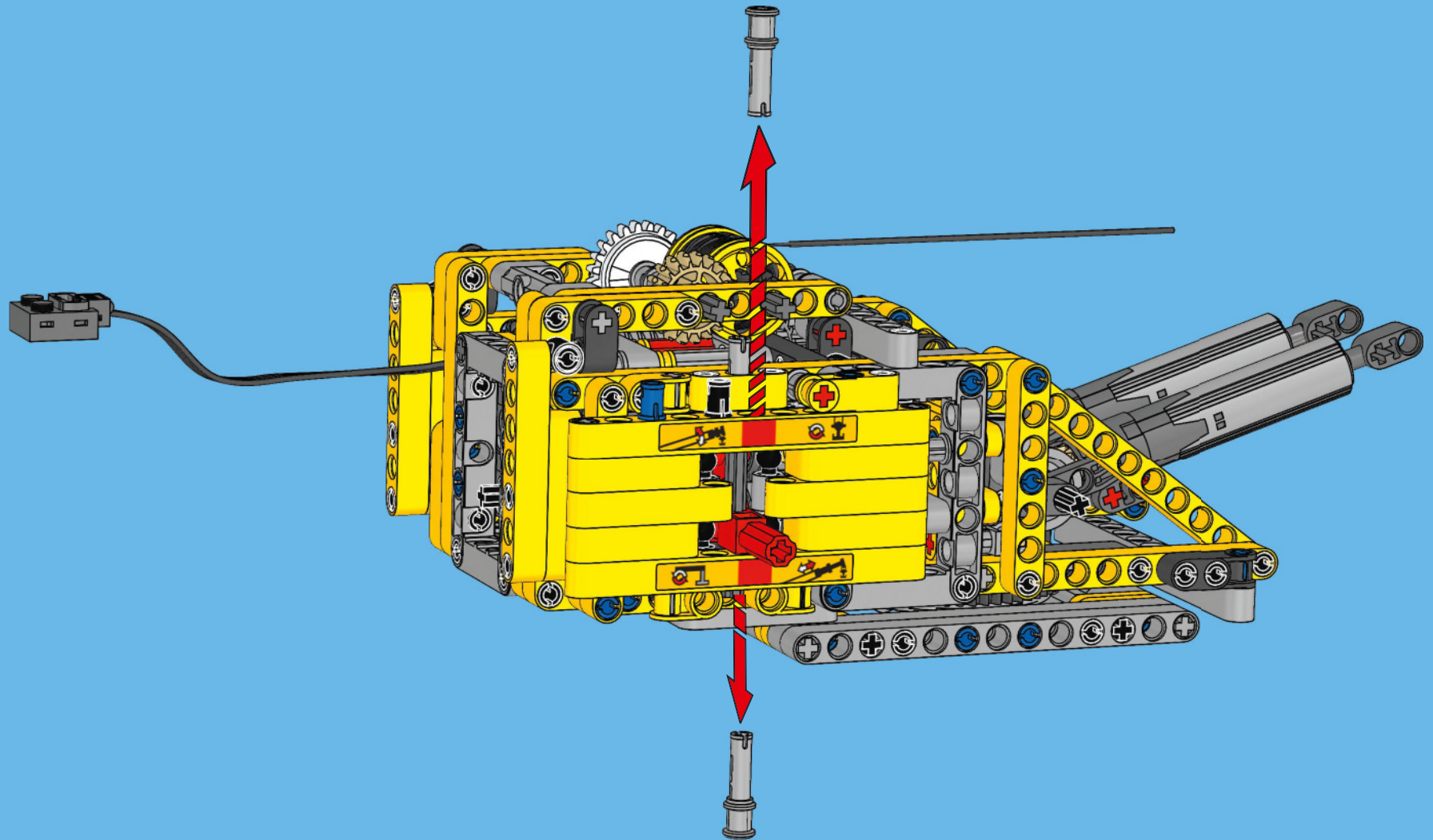





2x

# 103

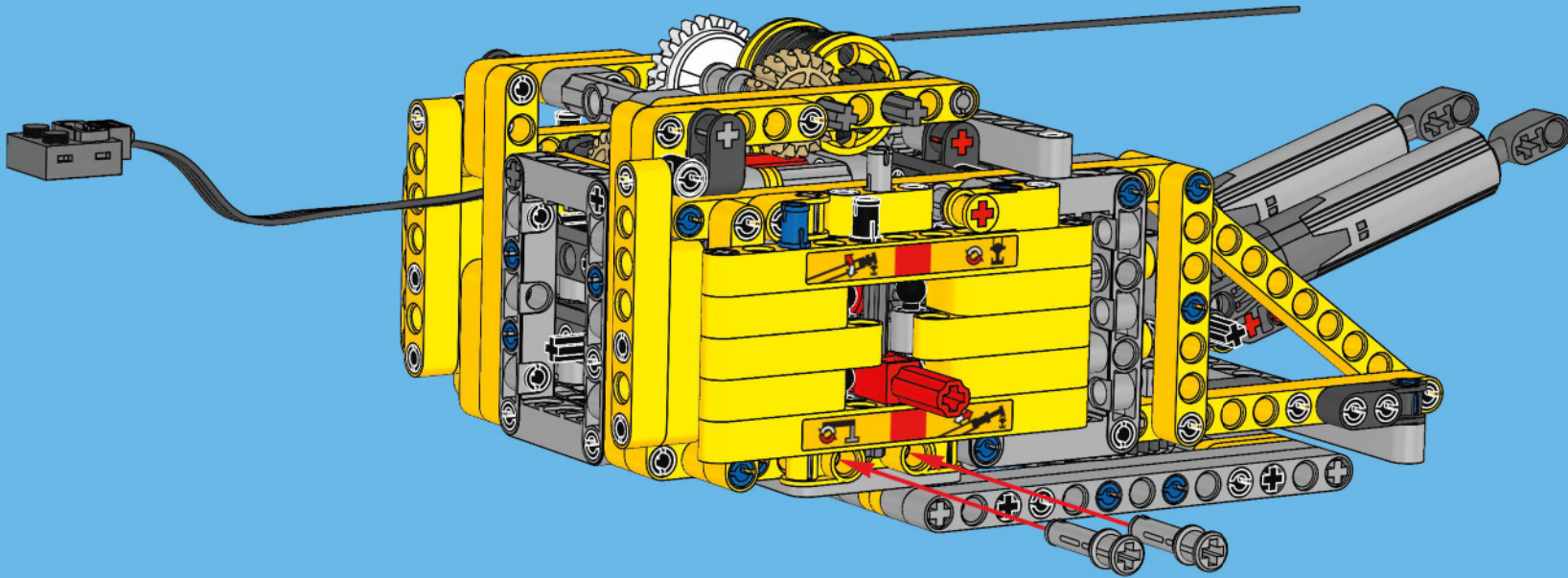

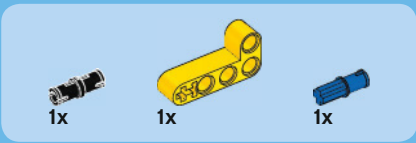

104

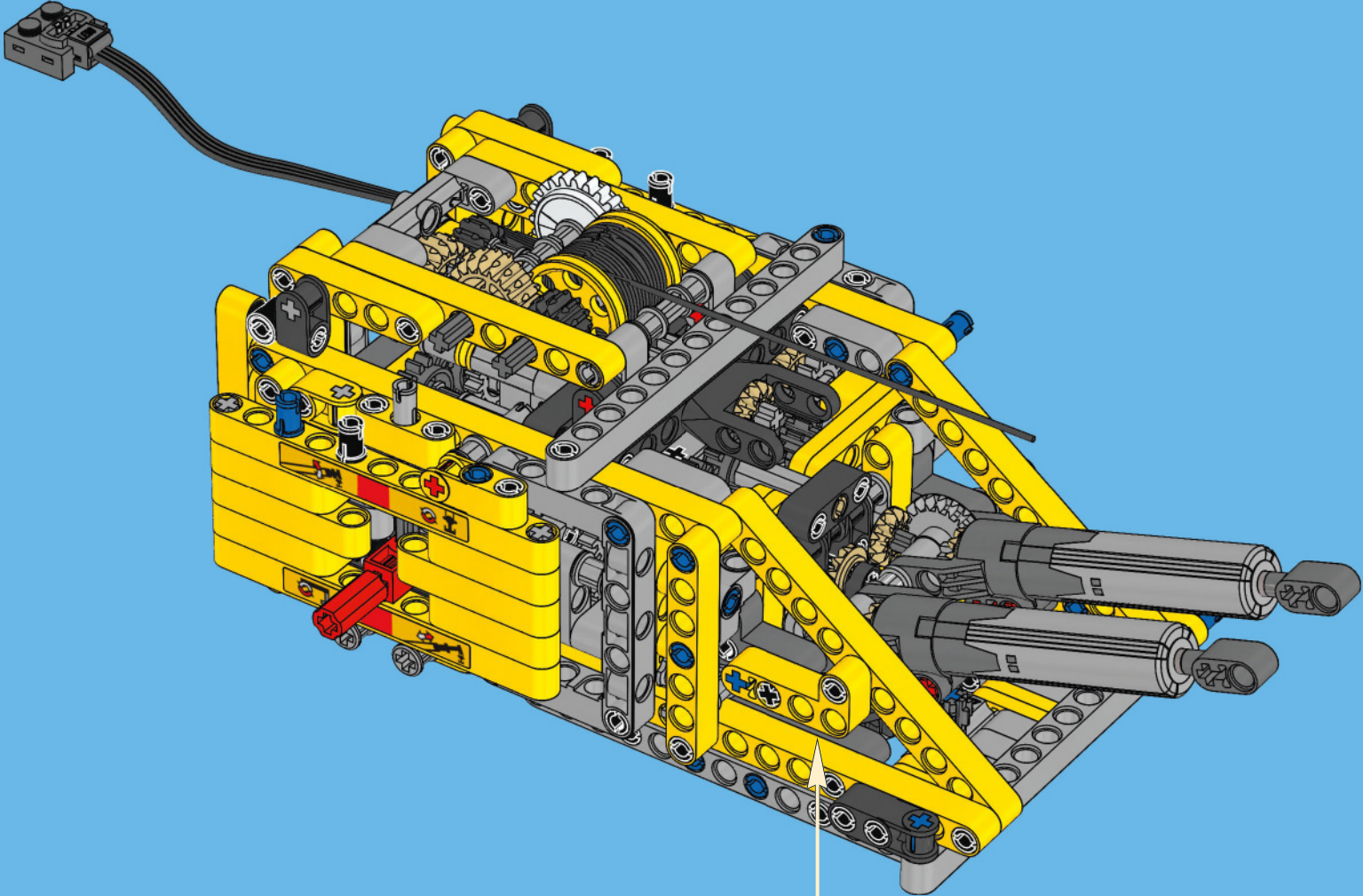



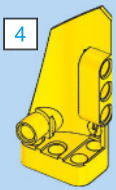
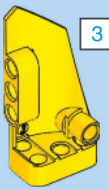

# 105

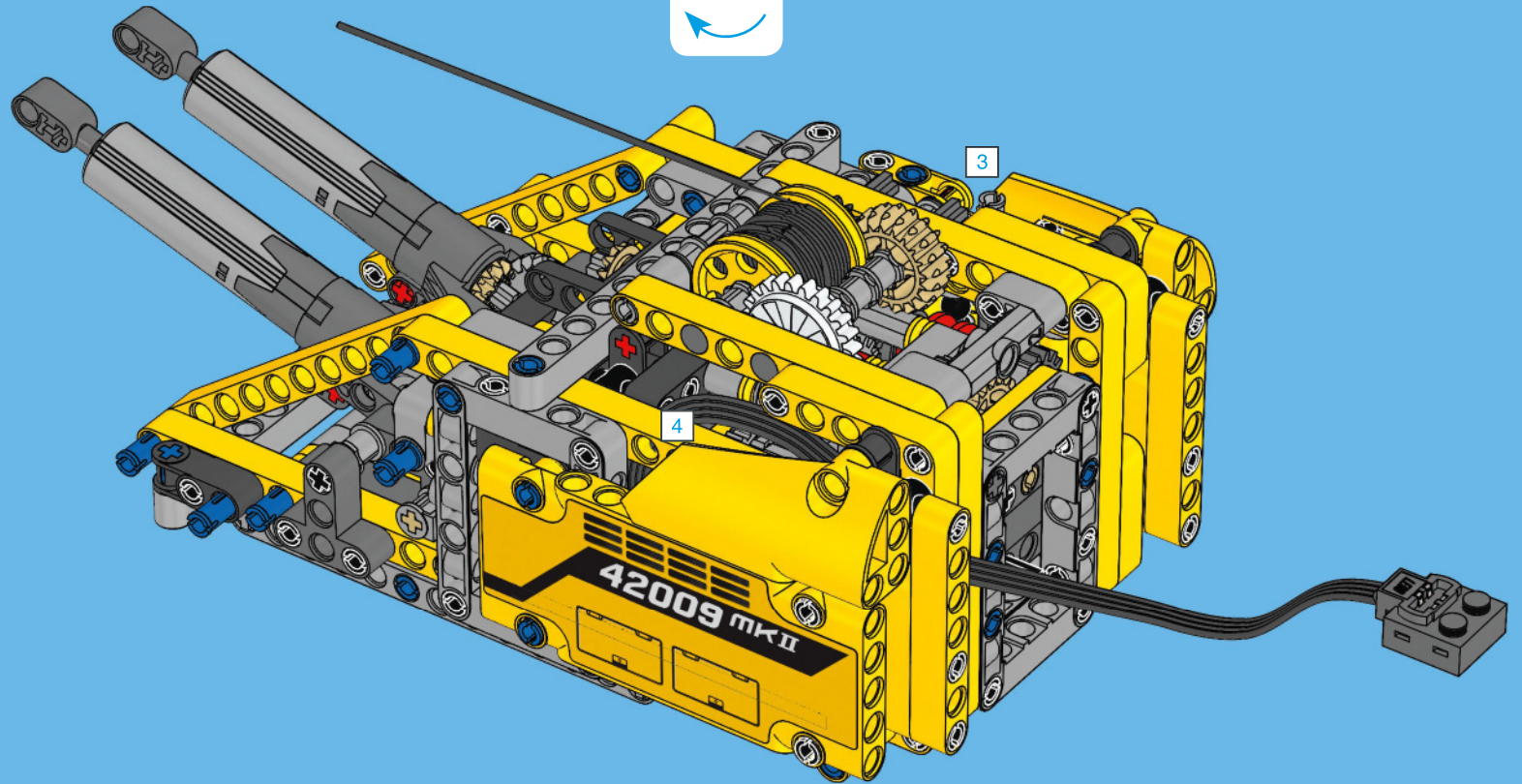

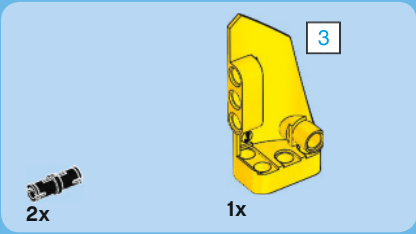
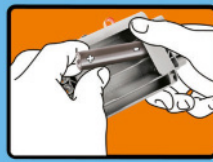
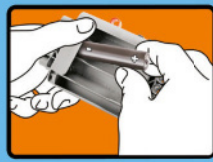
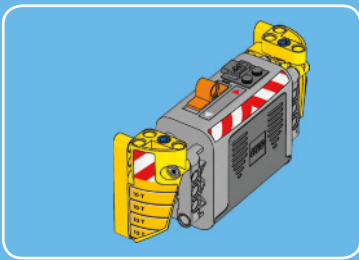

1

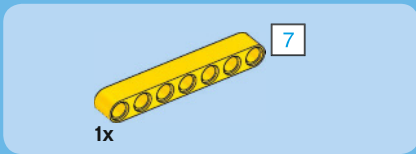
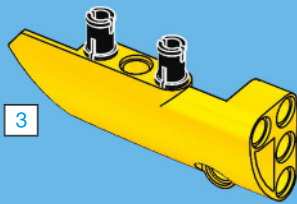

2

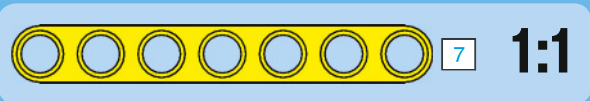
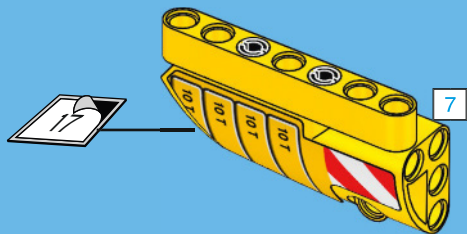

3

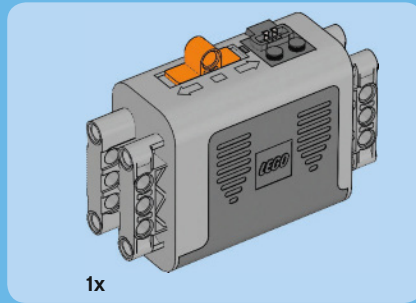
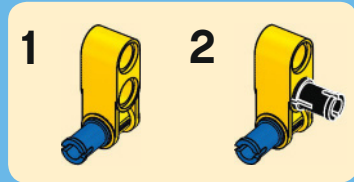
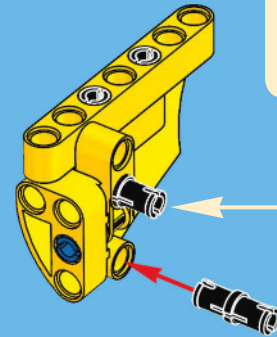

4

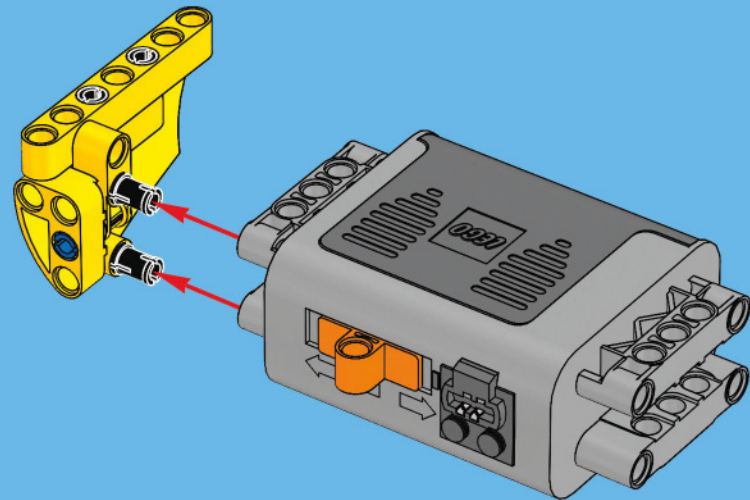





6x

5

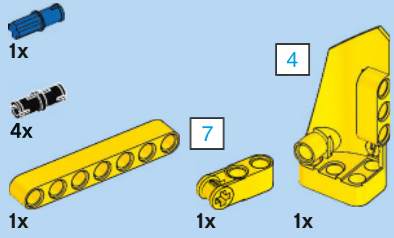
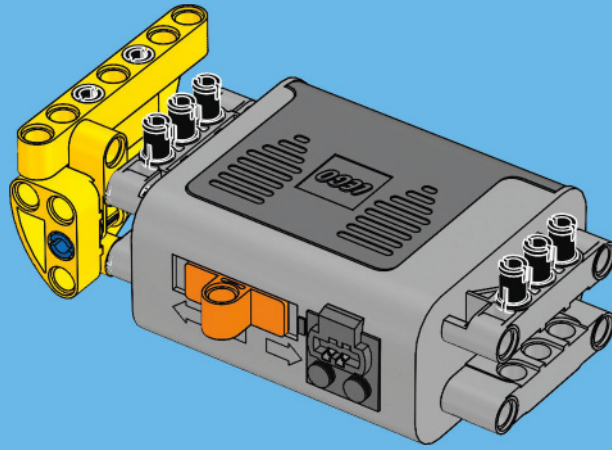

6

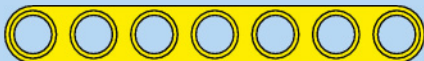
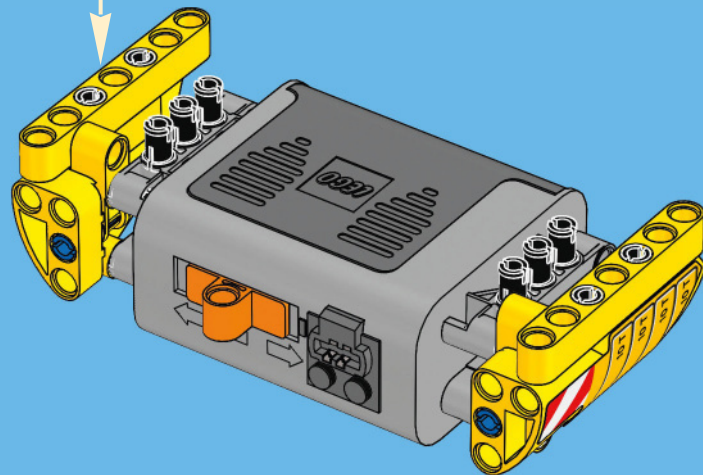
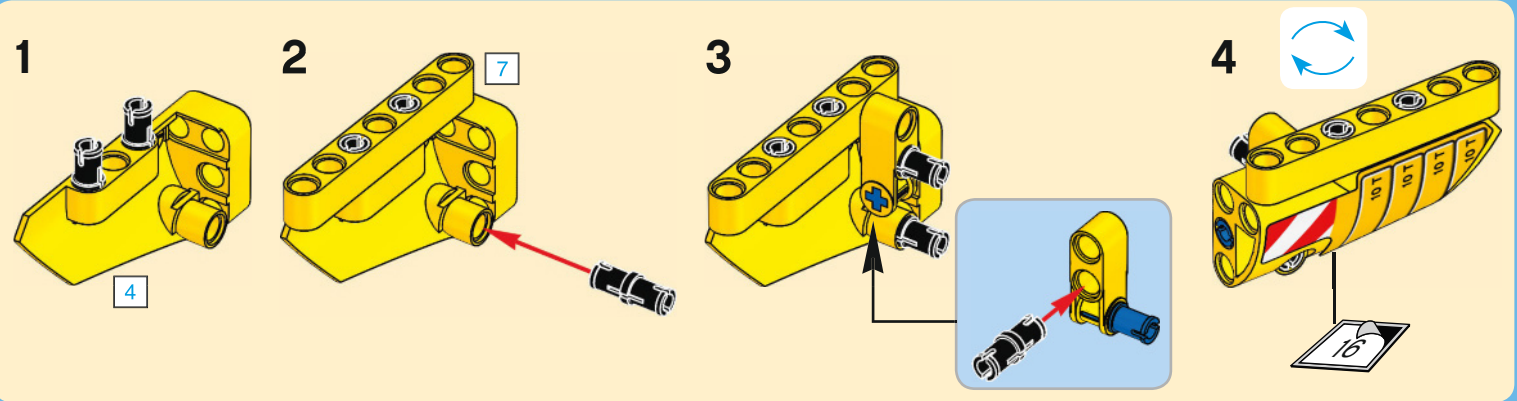

7

1:1

7

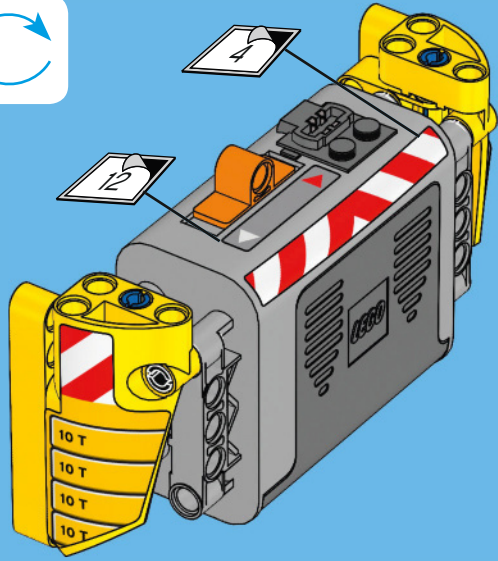

106

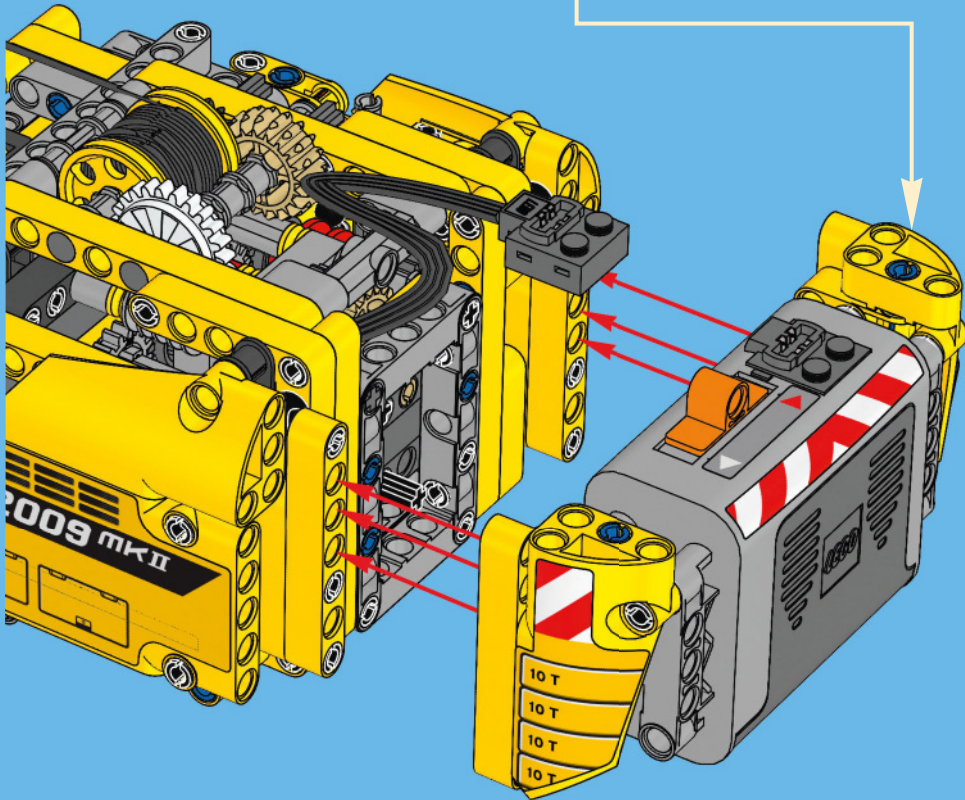

107

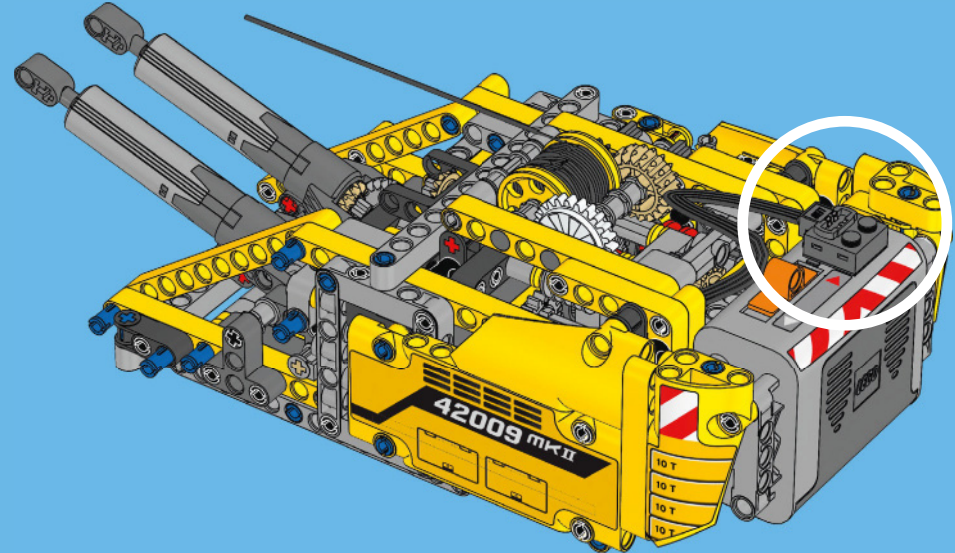



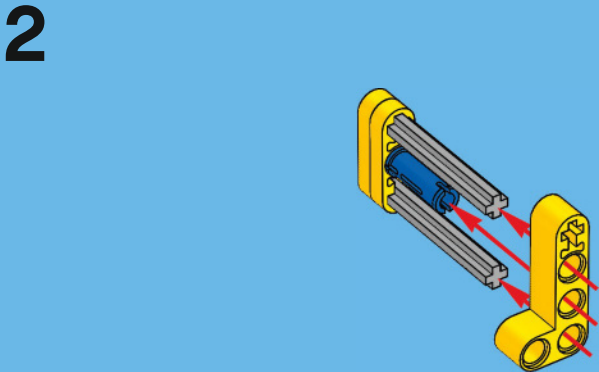
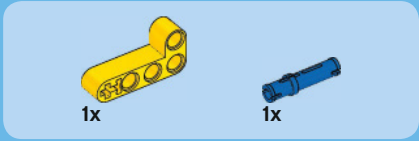
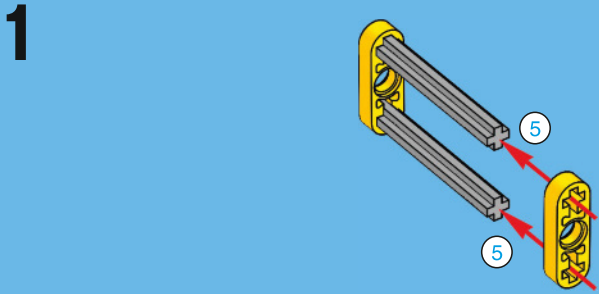
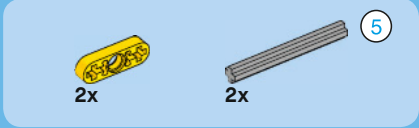
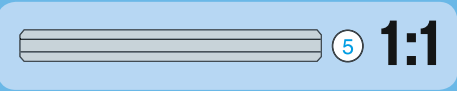
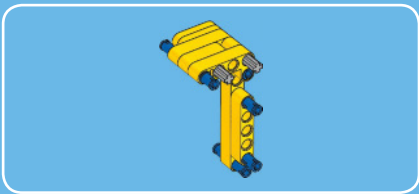

**3**

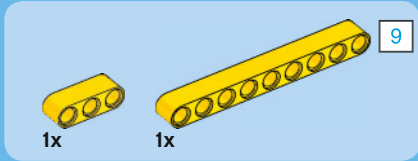
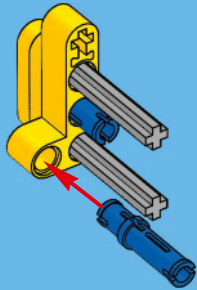

**4**

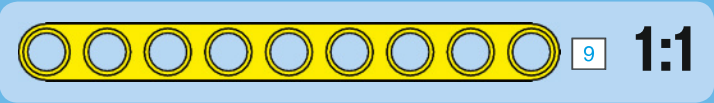
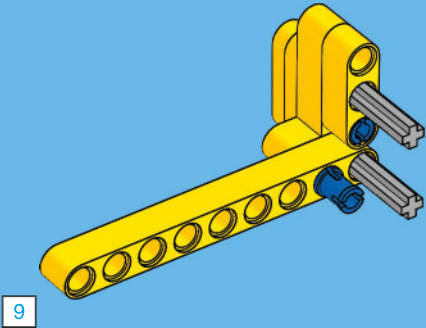

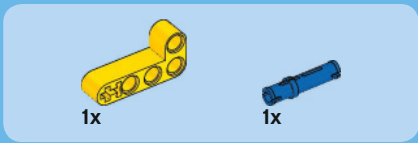

5

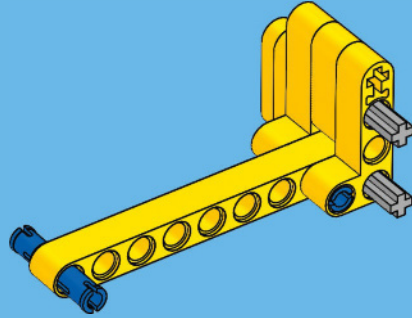

6

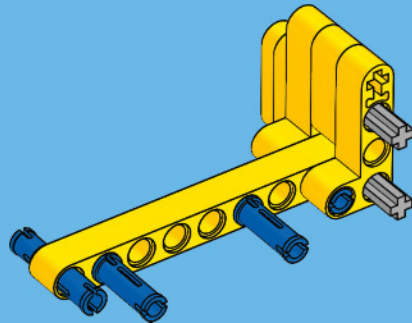

7

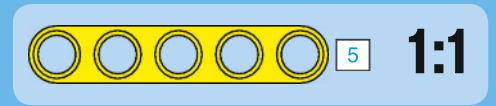
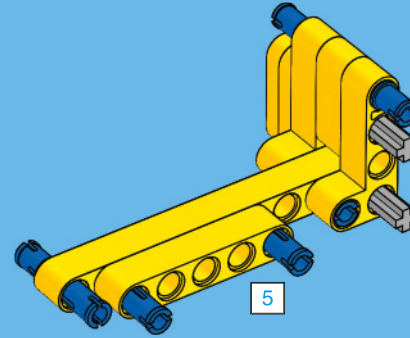

8

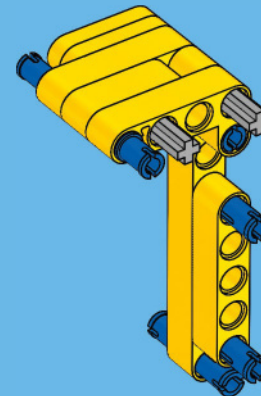



108

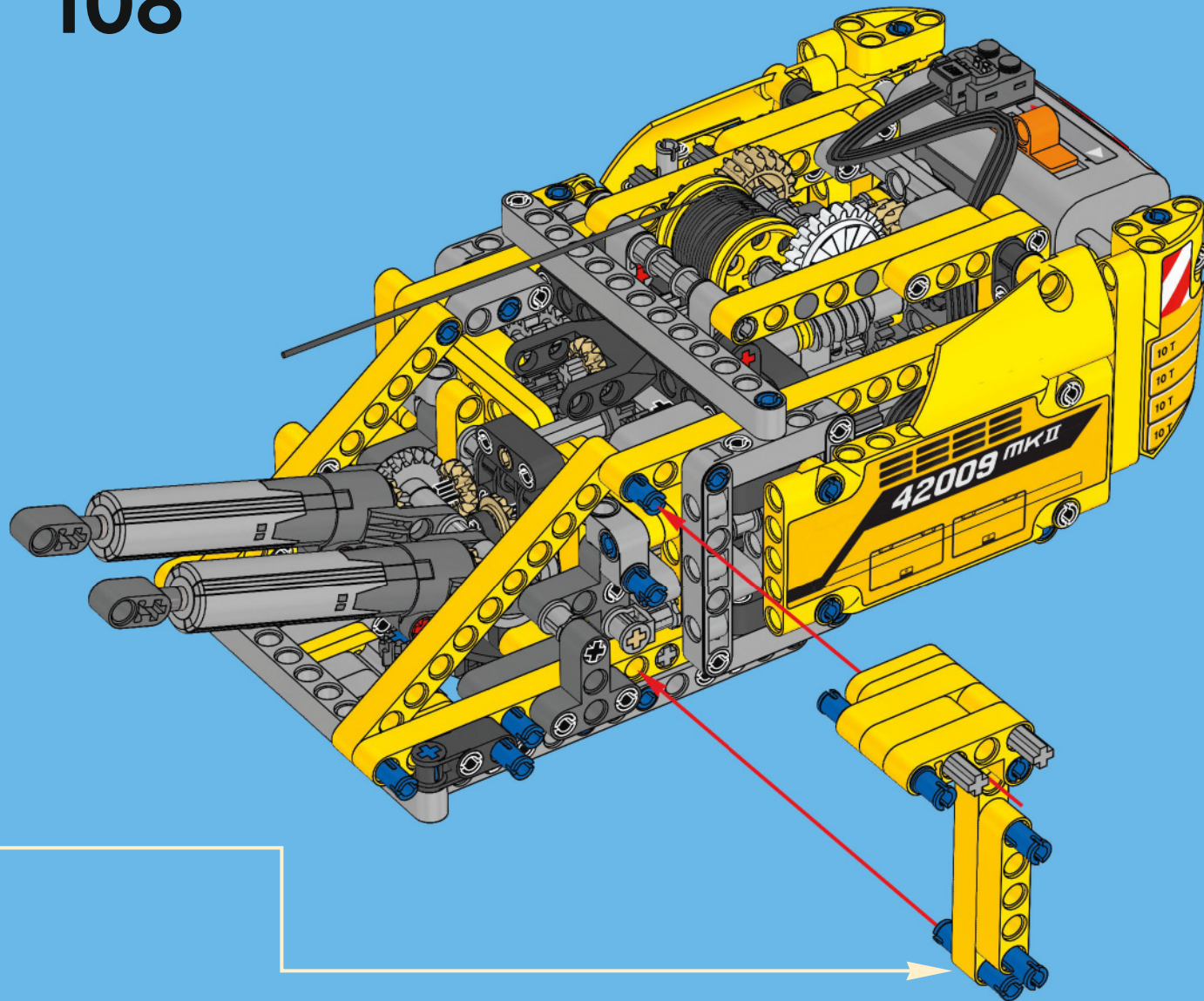

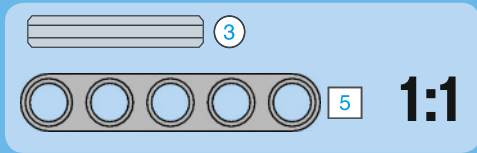
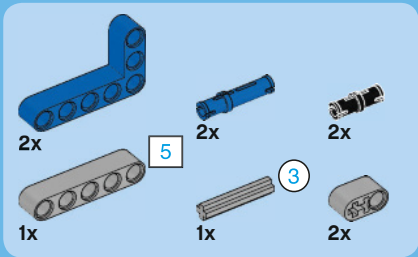

# 109

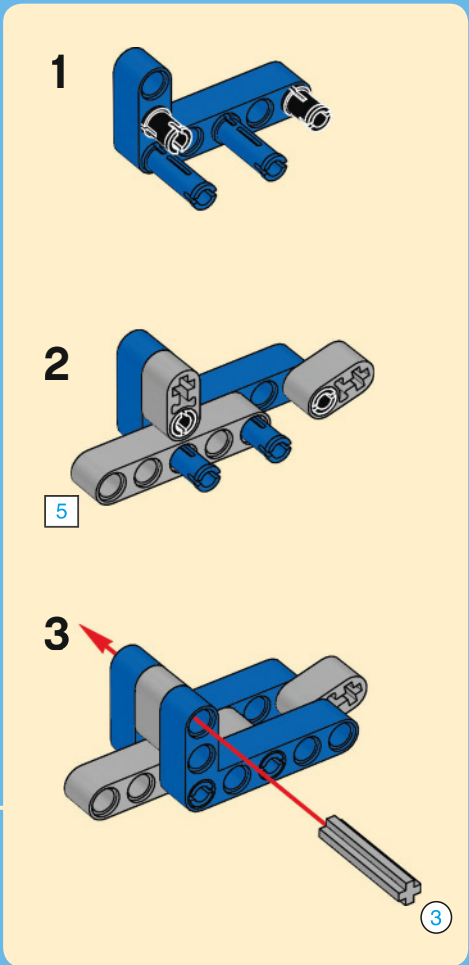
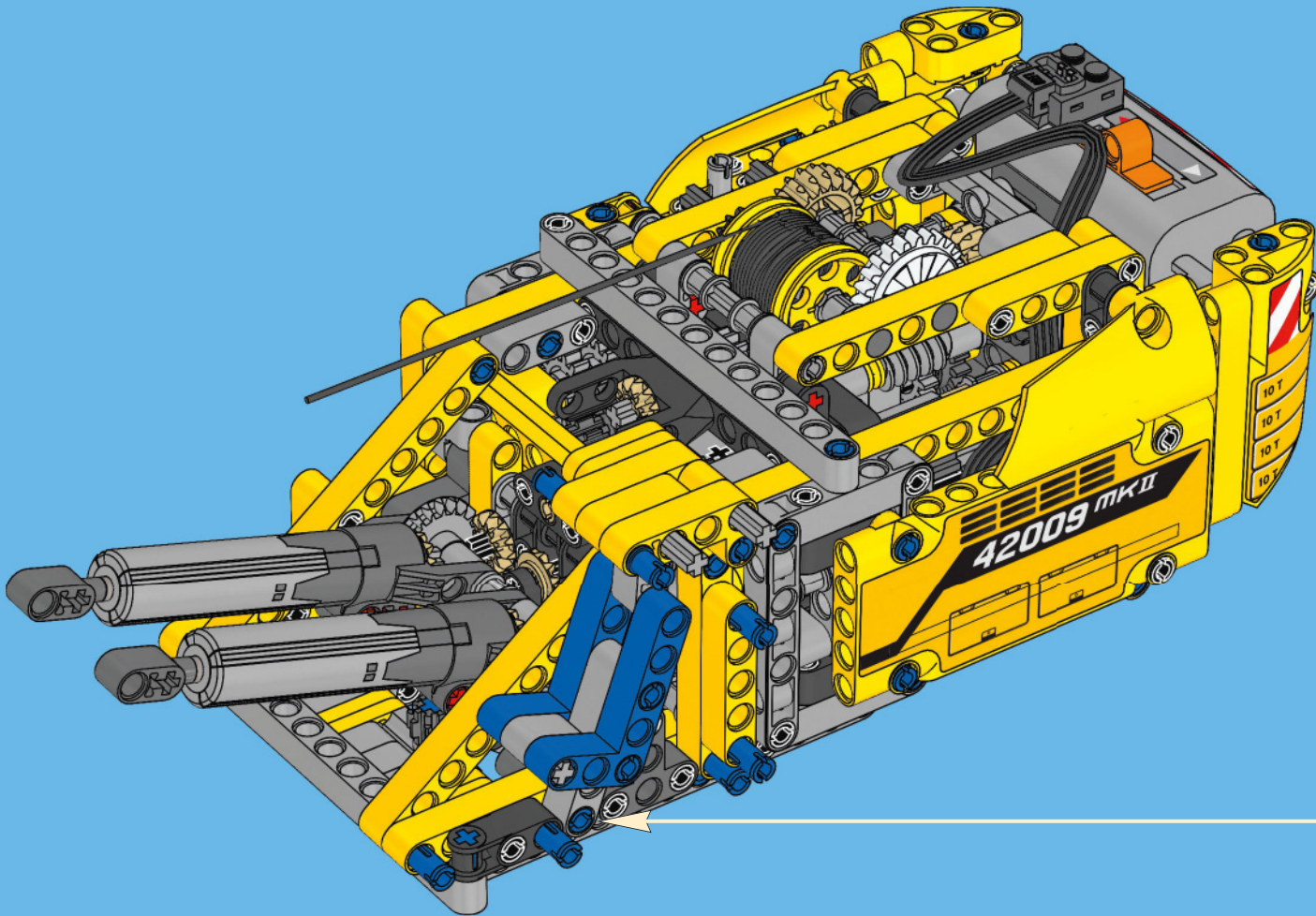



2x

2x

1x

2x

# 110

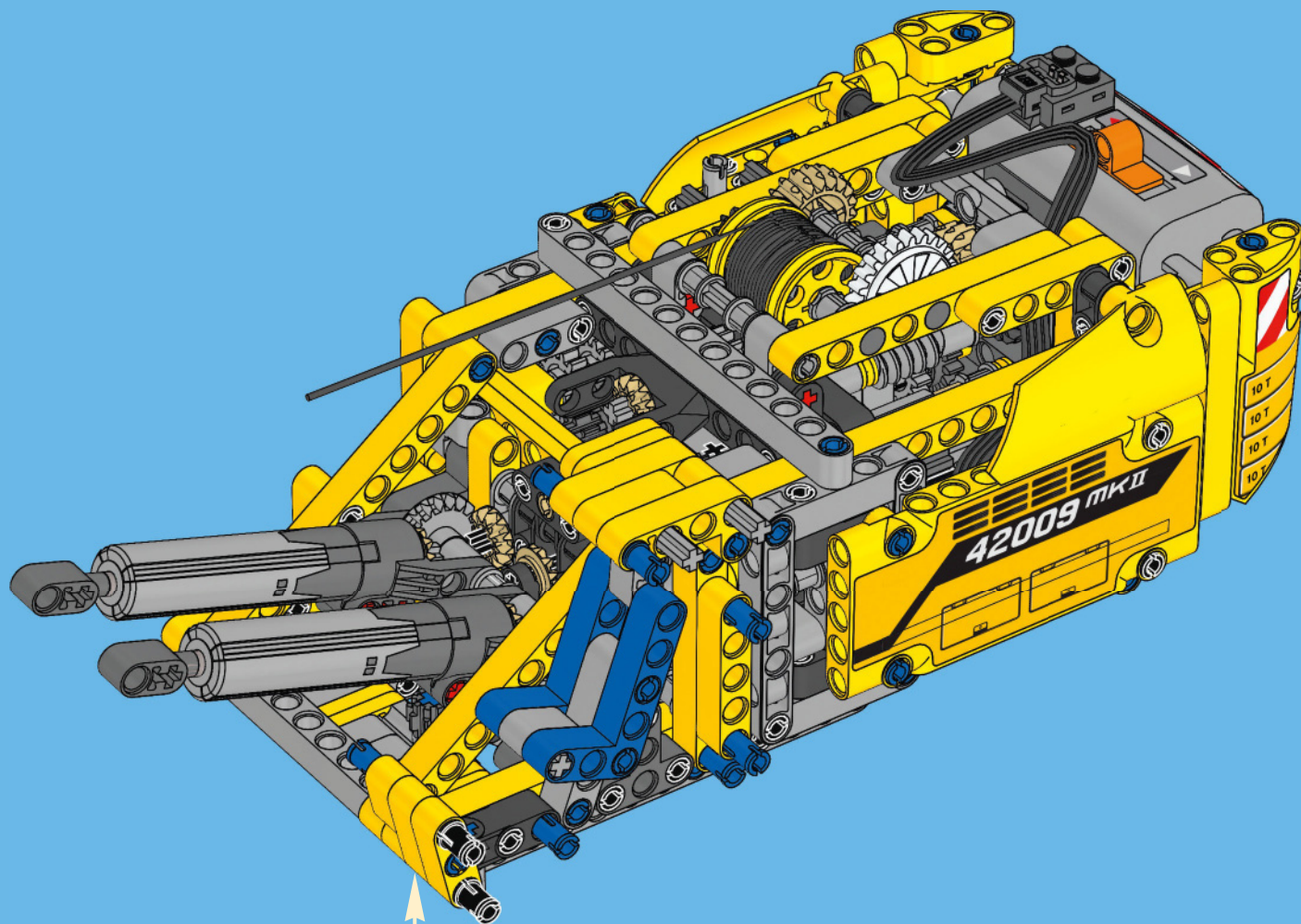

1



2

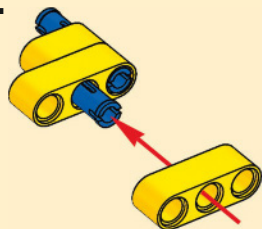

3



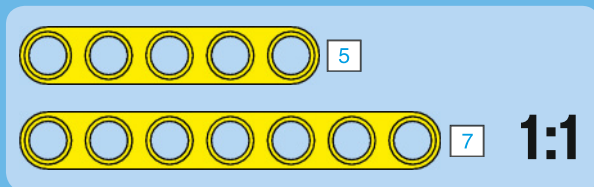
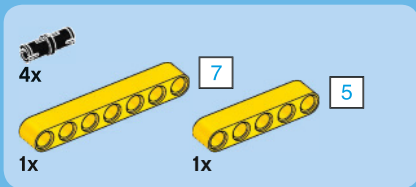

# 111

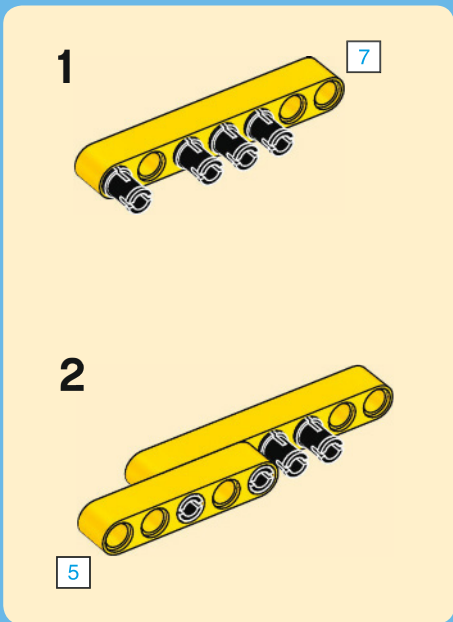
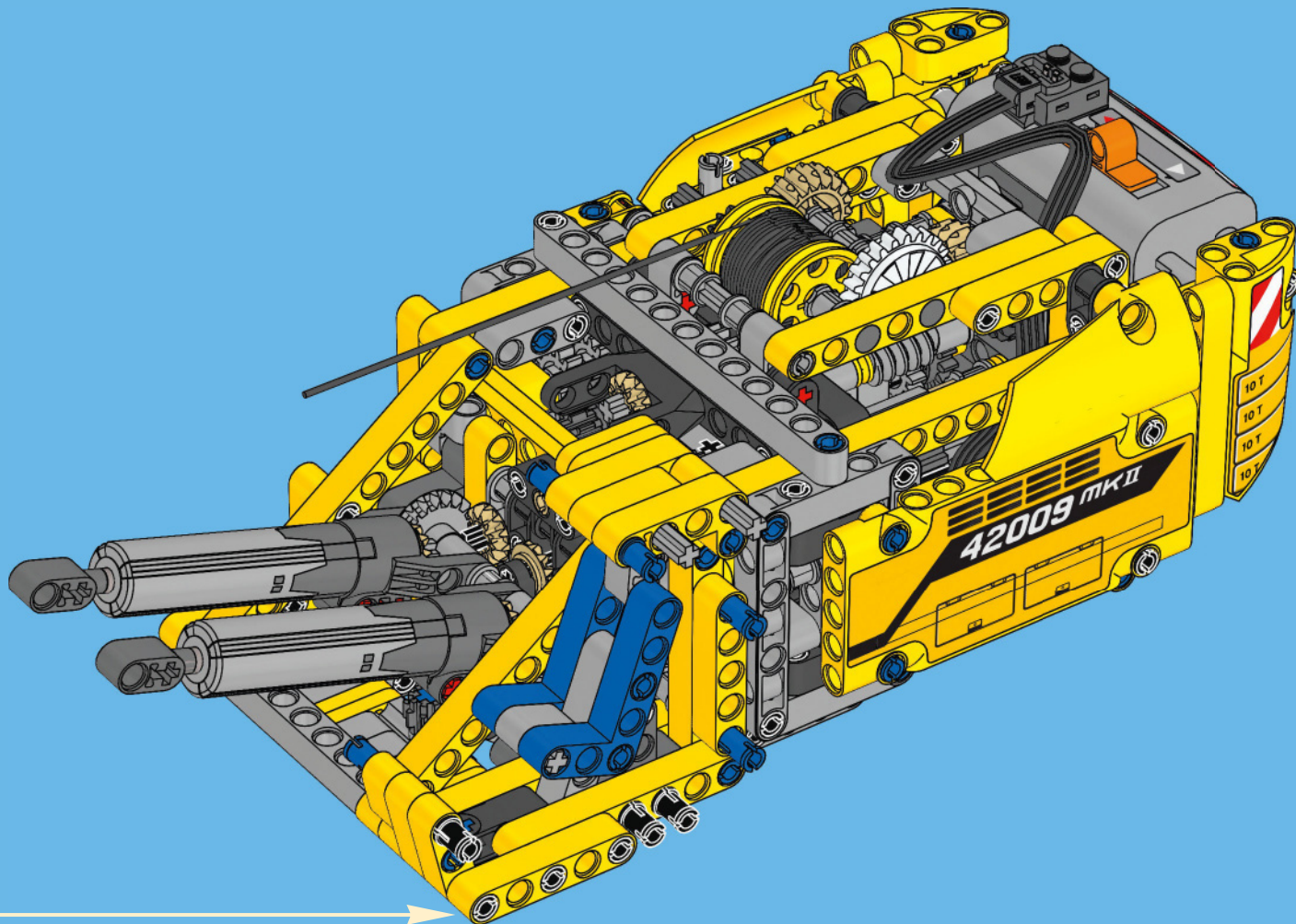



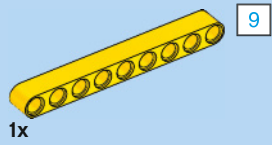

1x

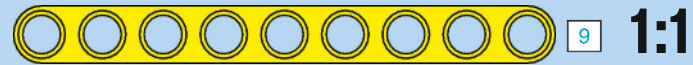

1:1

# 112

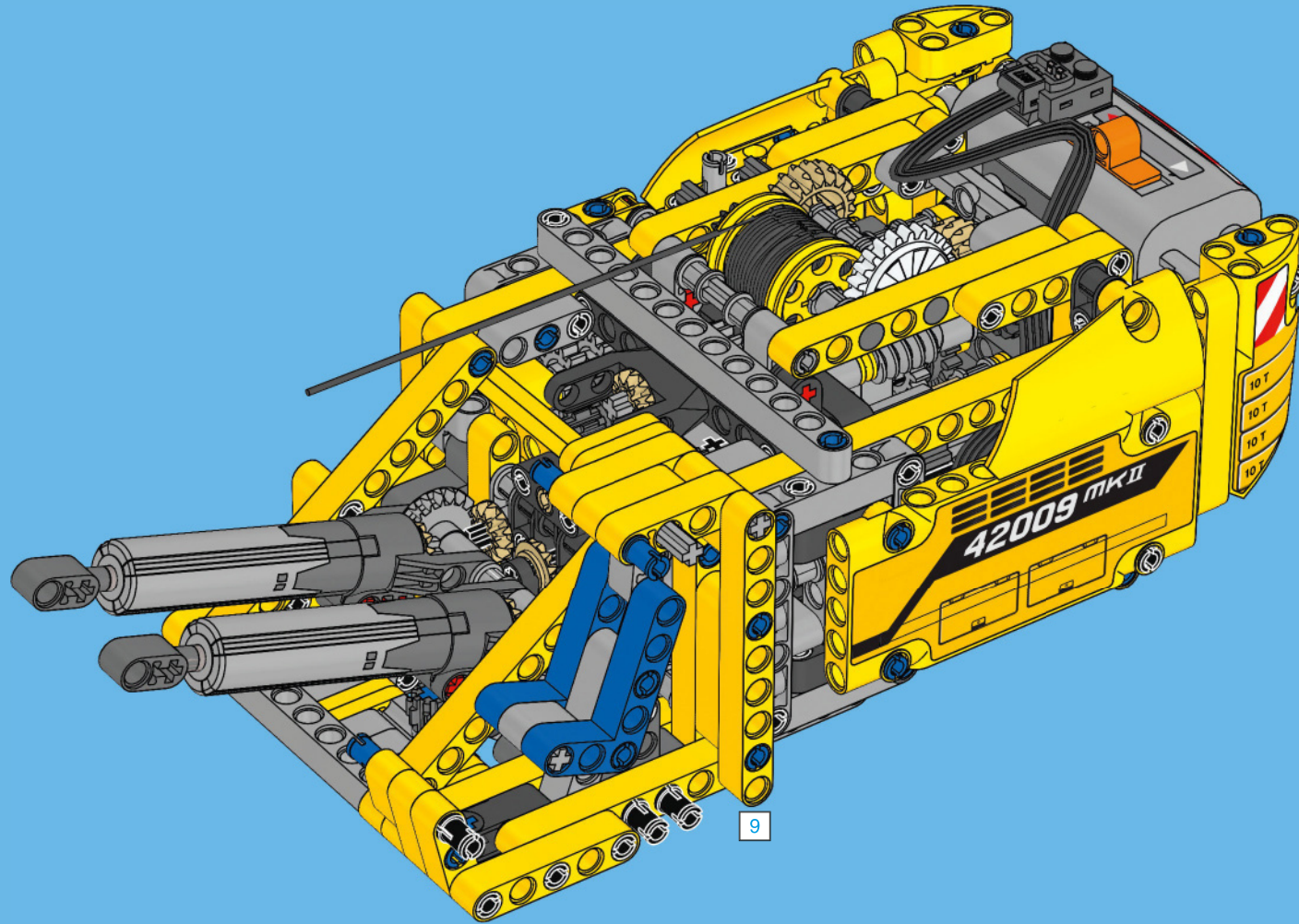

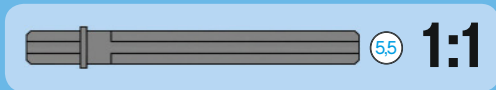
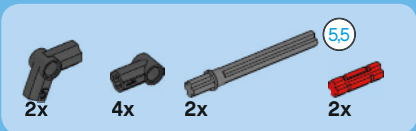

# 113

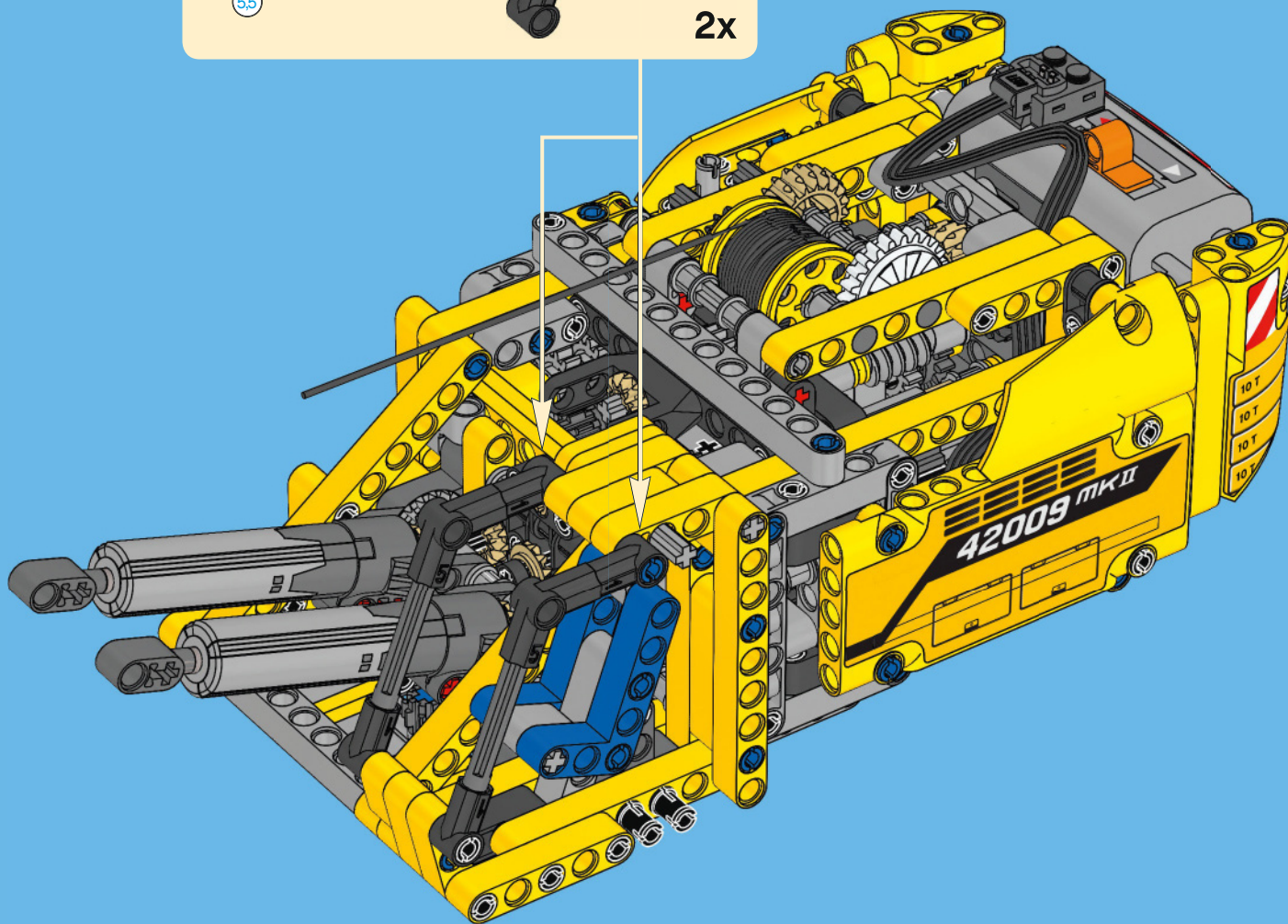
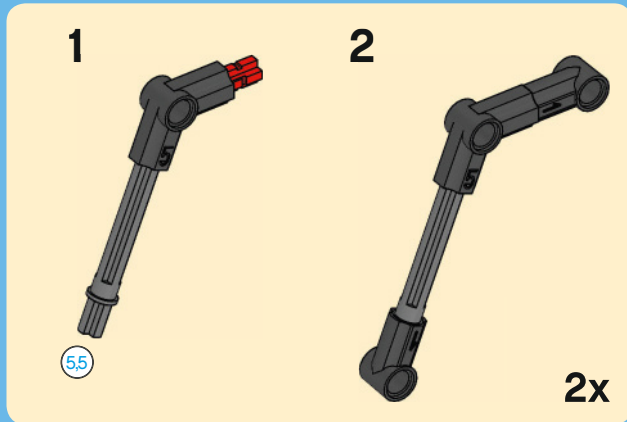



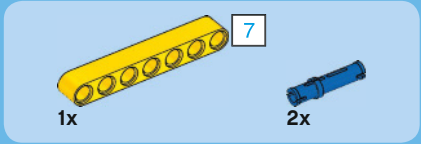
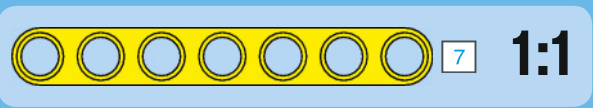
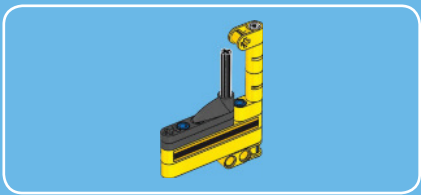

1

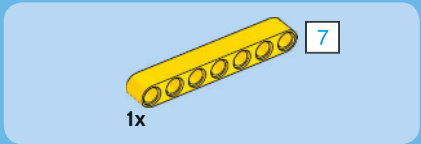
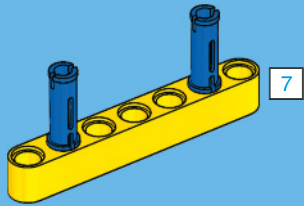

2

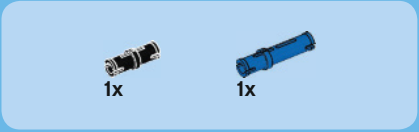
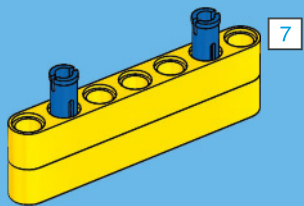

3

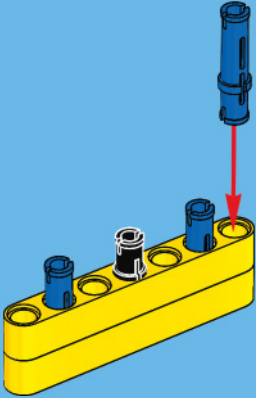

4

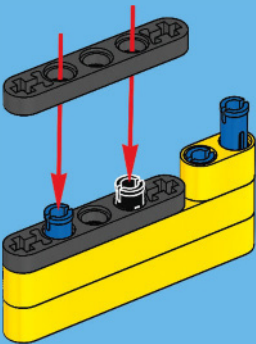

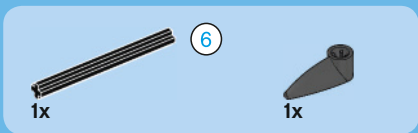

5

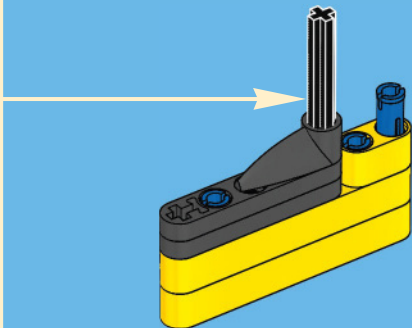
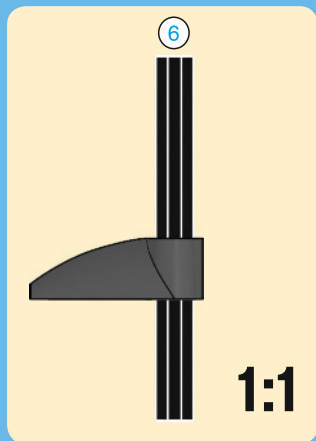

6

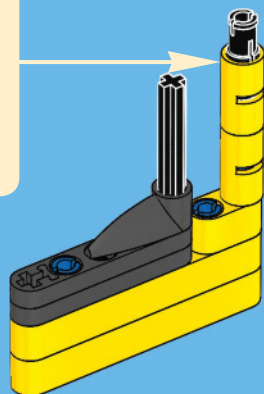
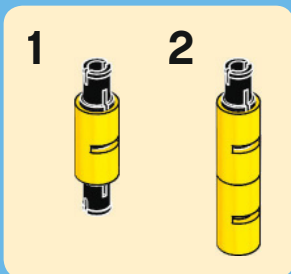

7

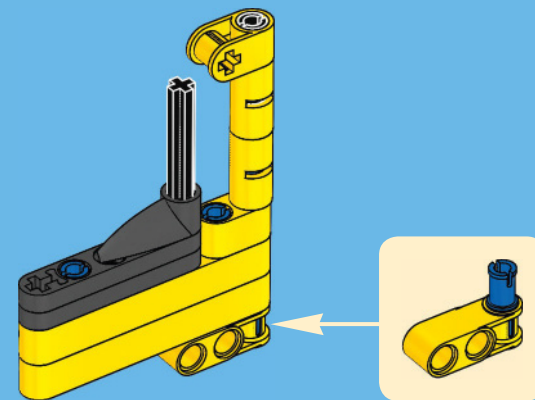

8

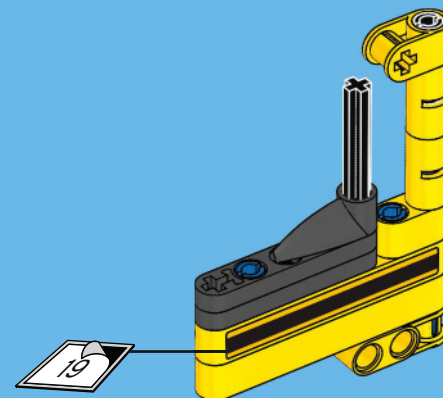



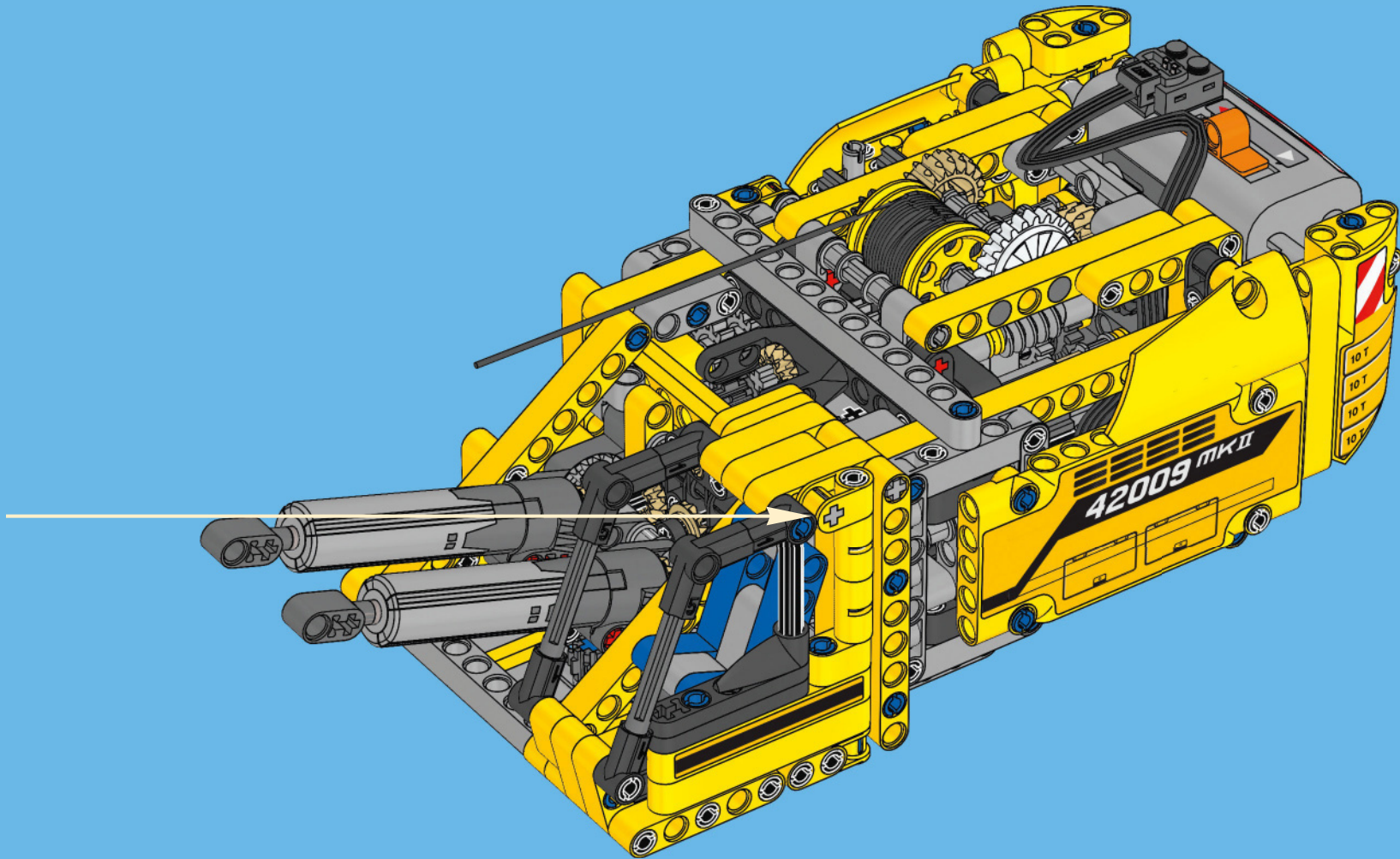

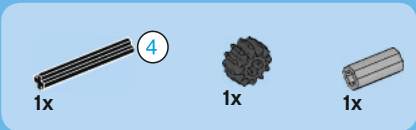

# 115

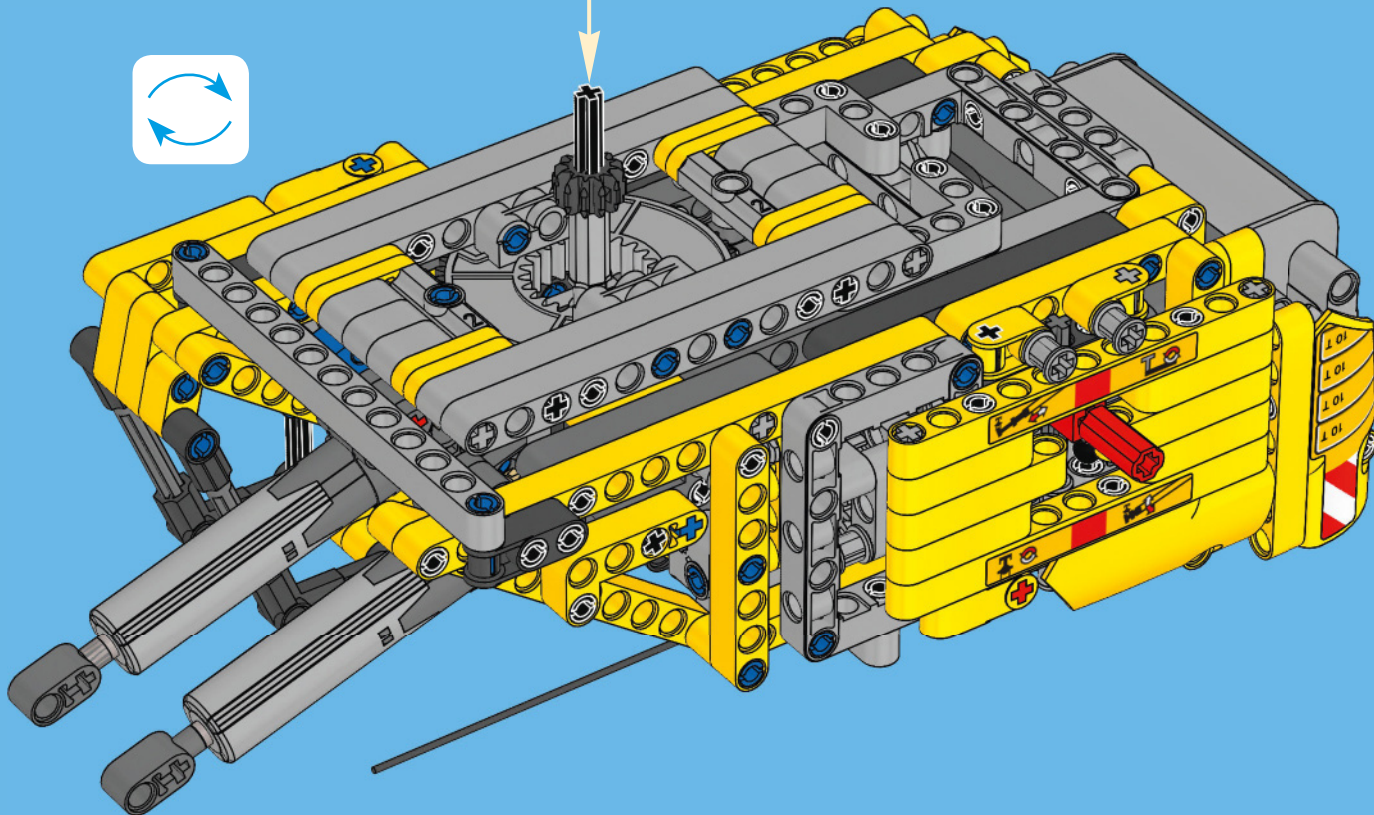
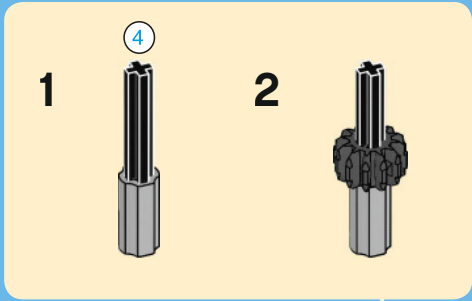



116

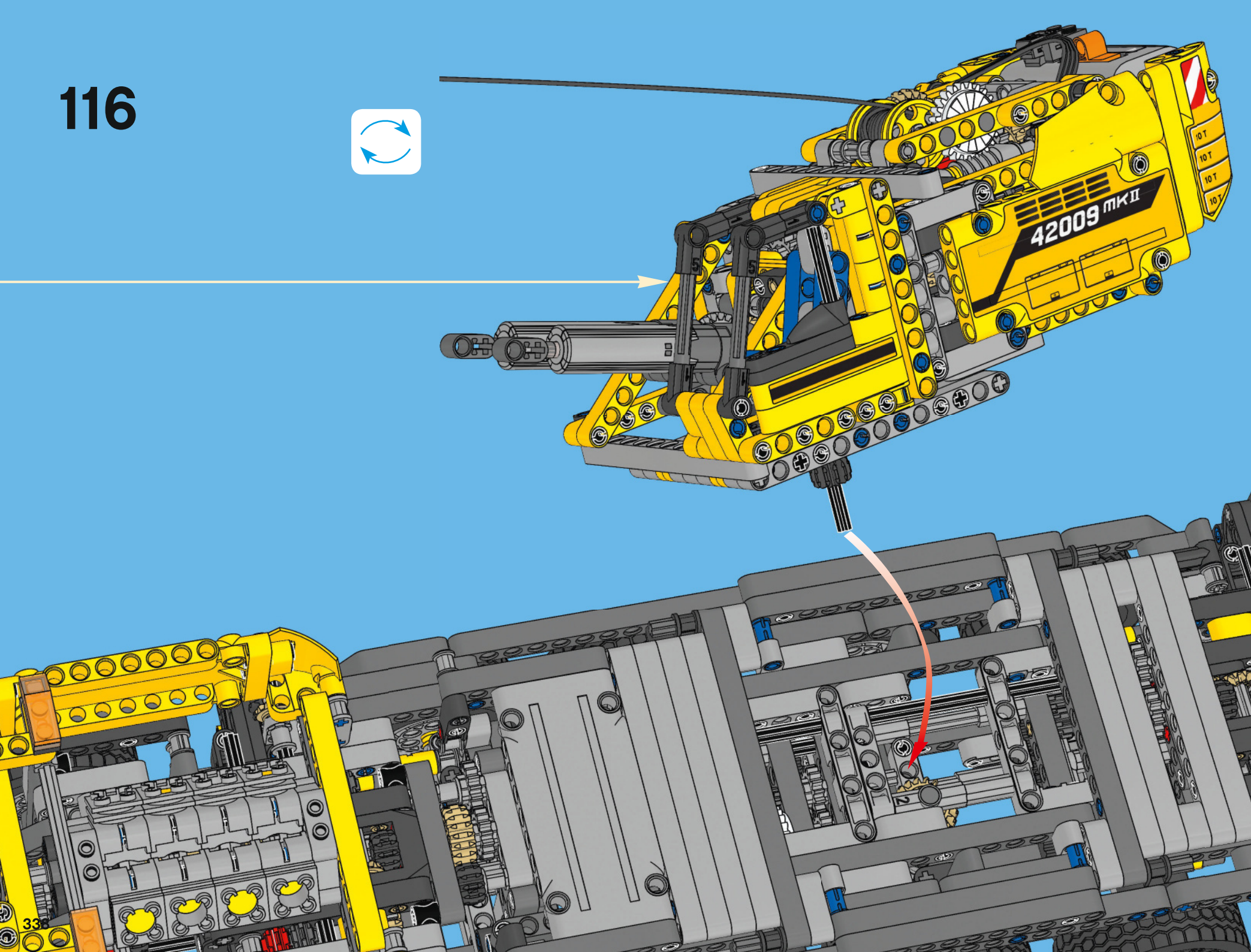



117

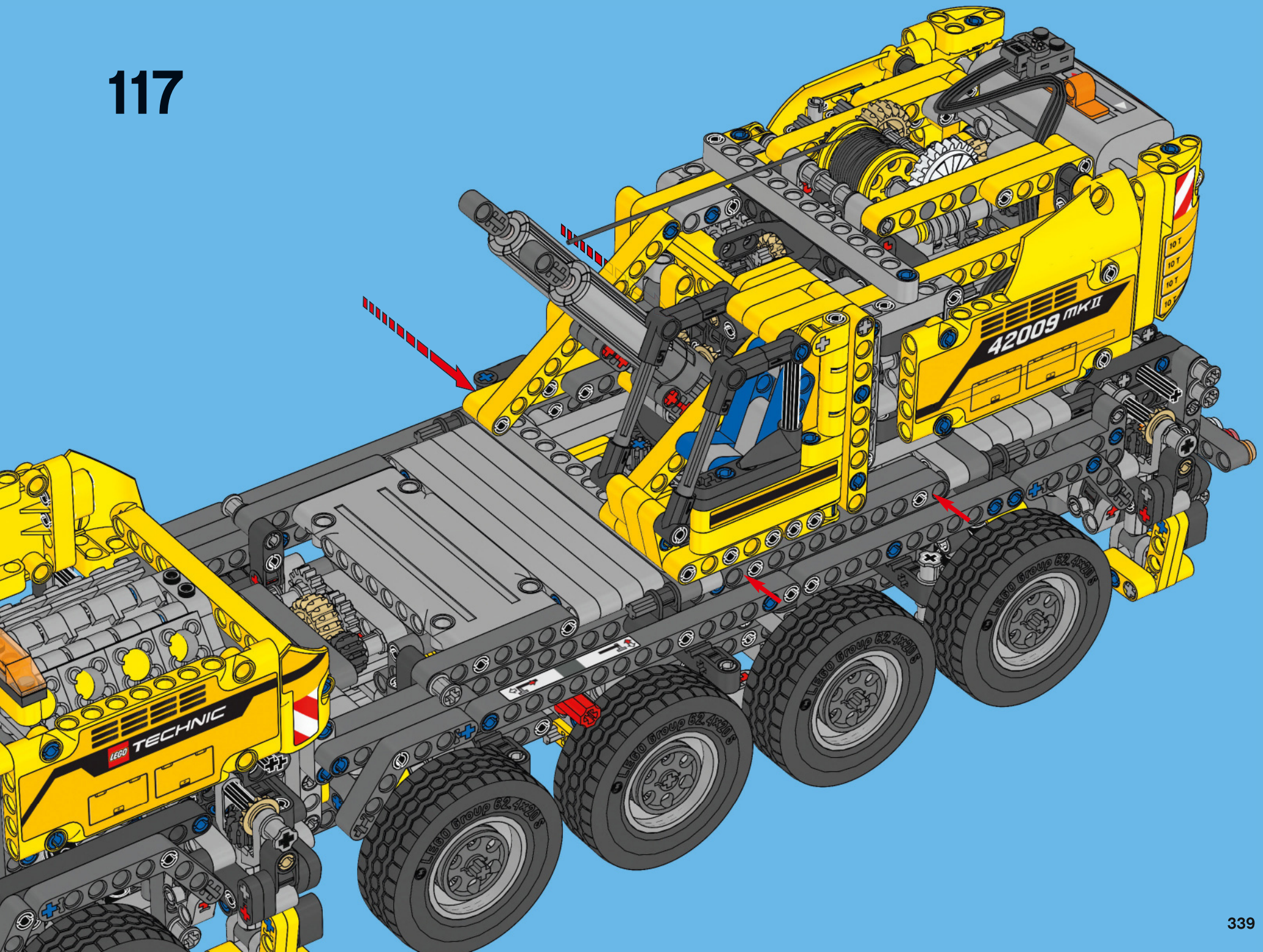



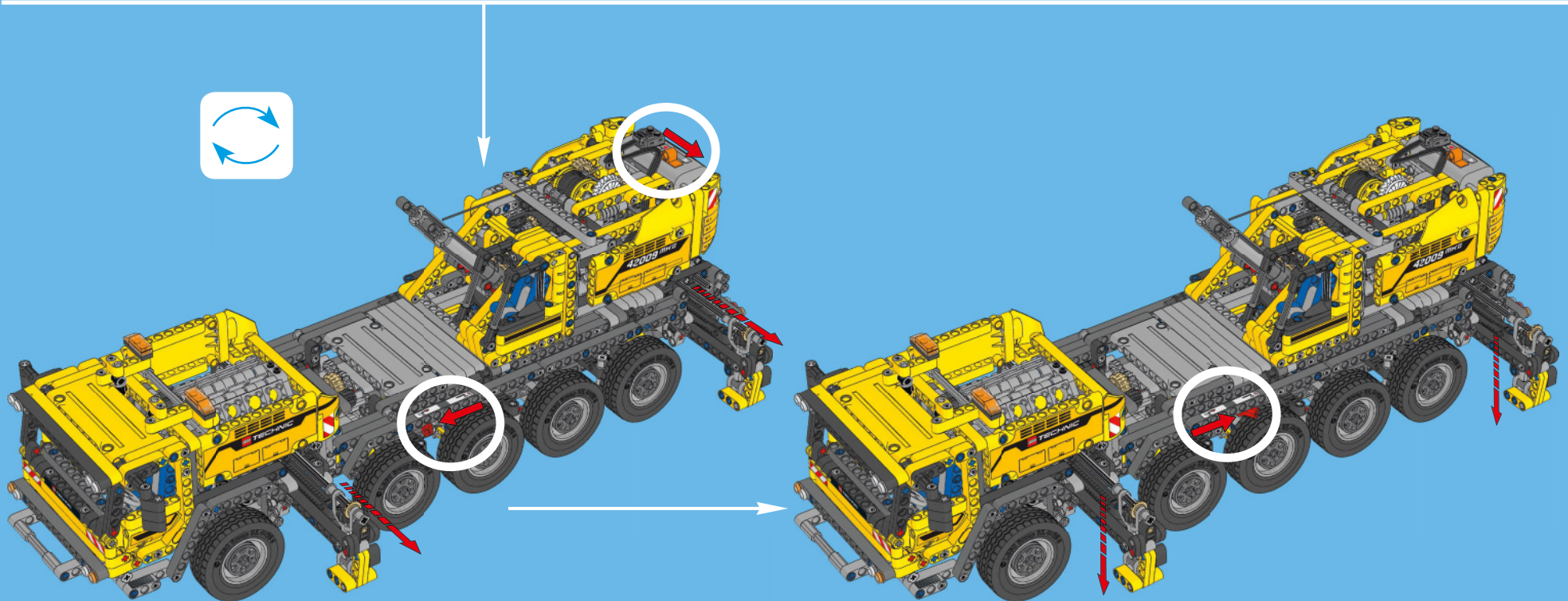
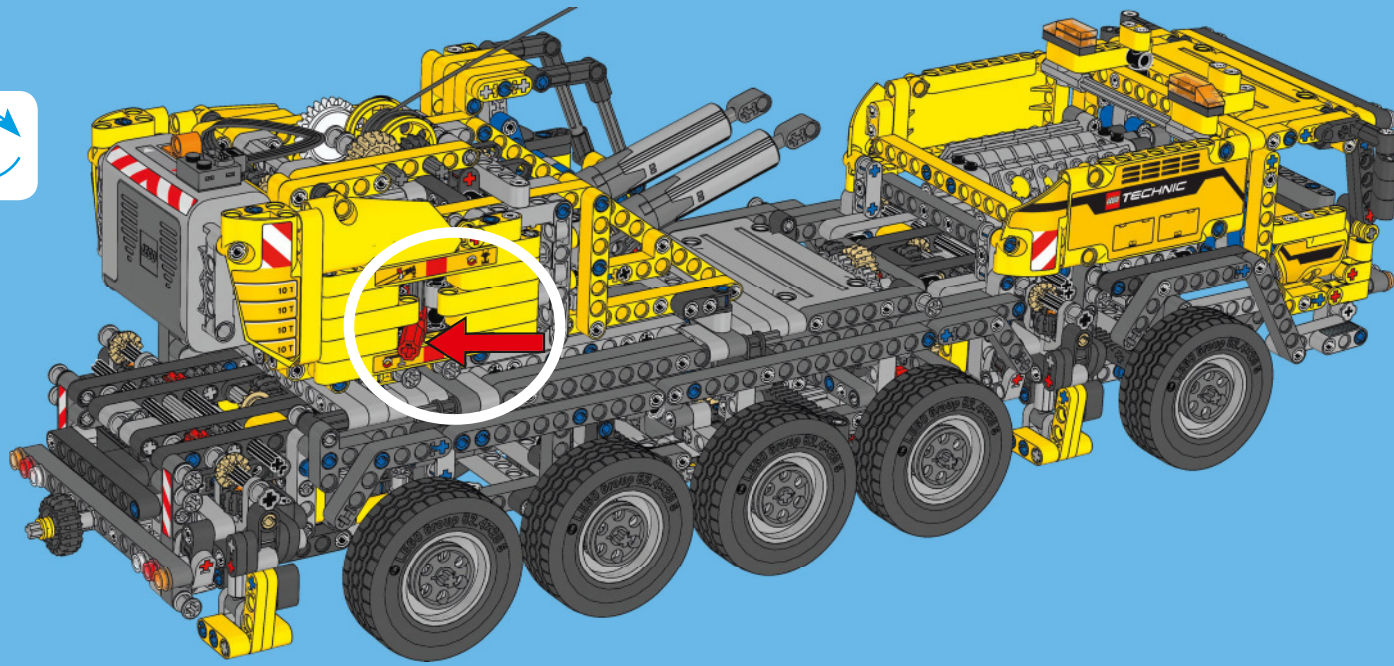



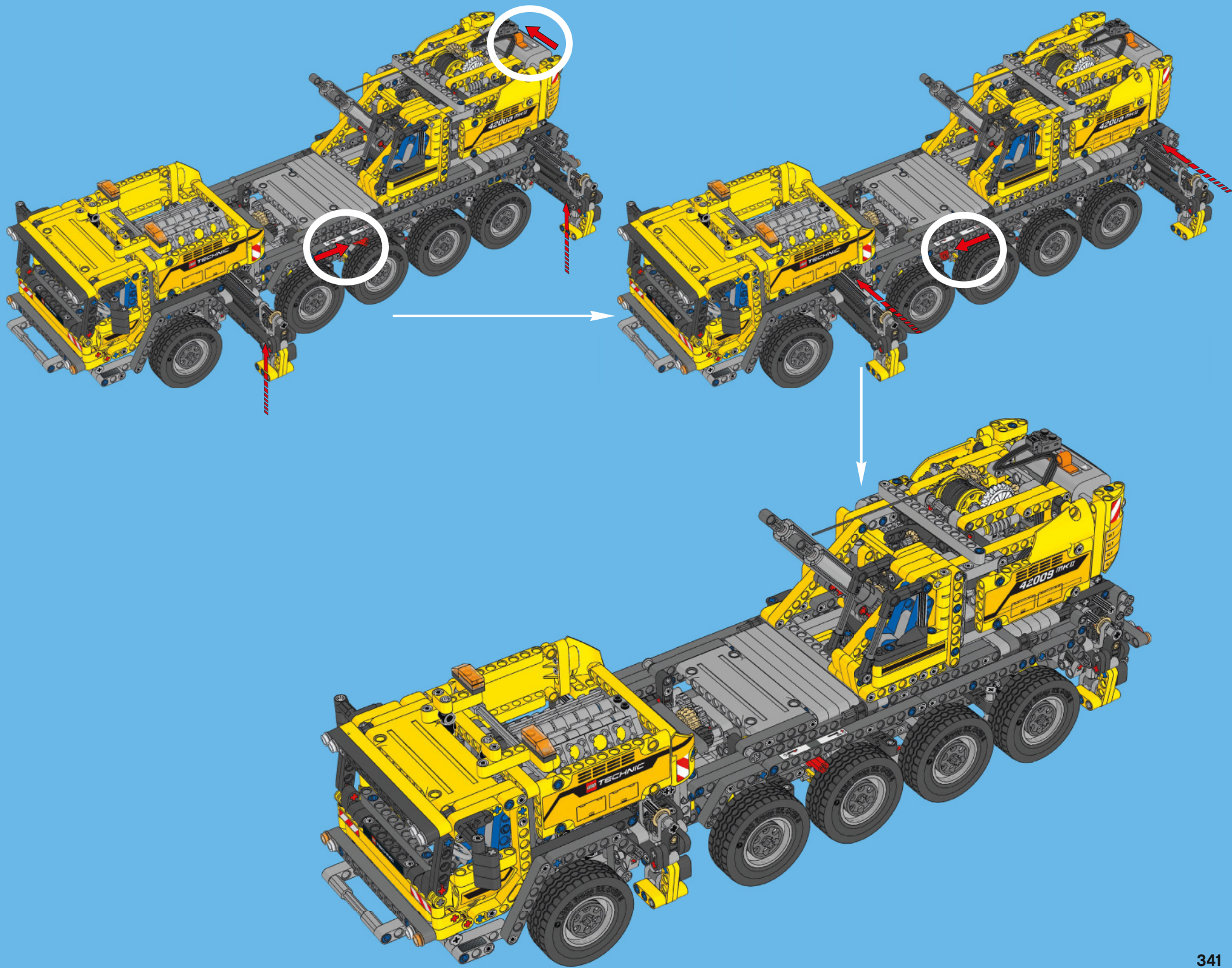



4x

3

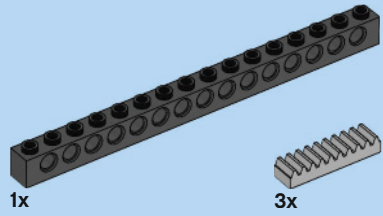
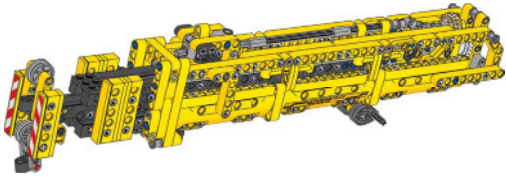
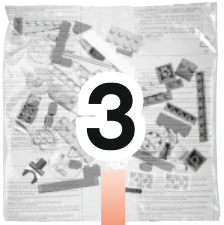

1

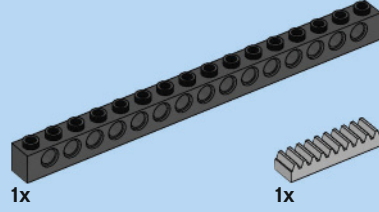
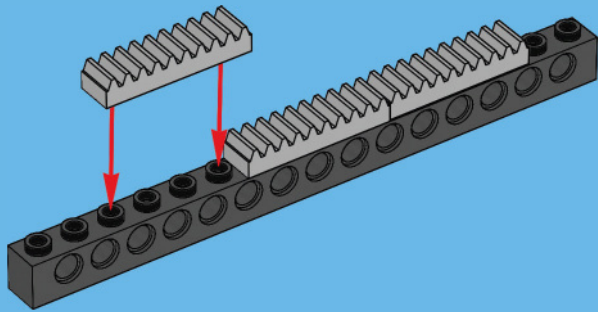

2

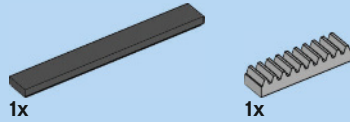
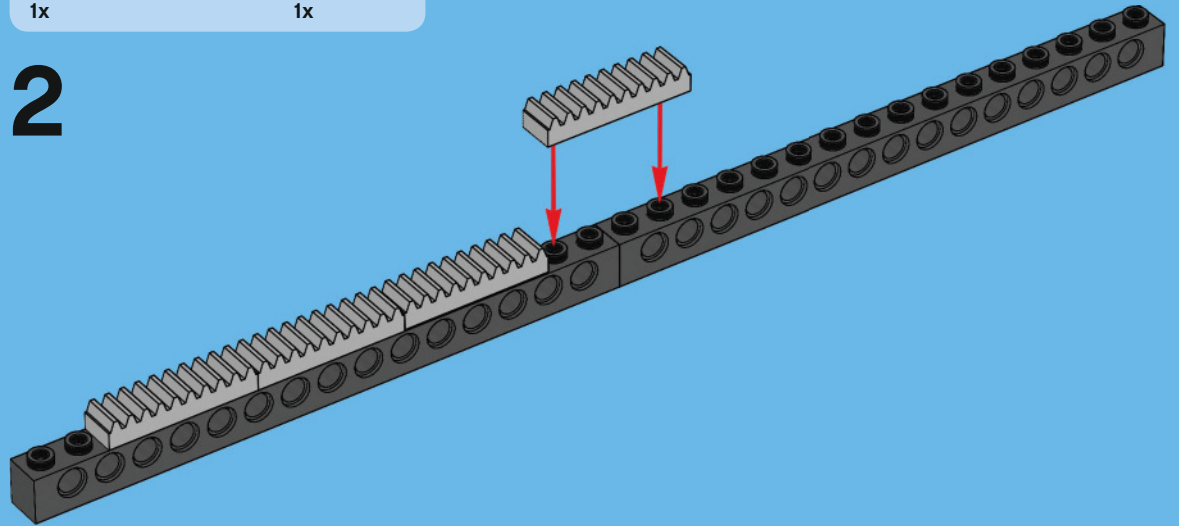

3

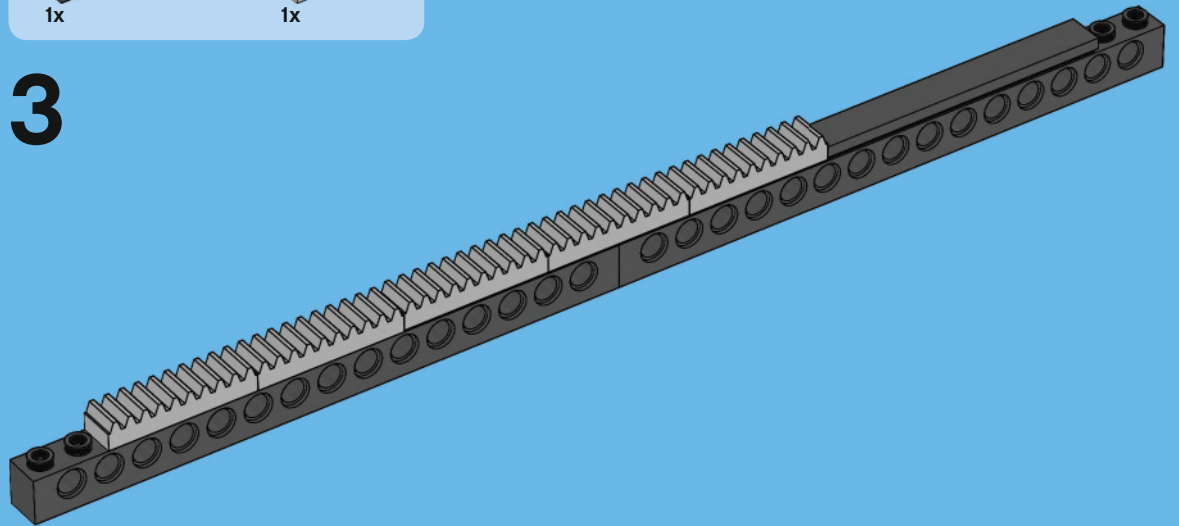



3x



2x

4

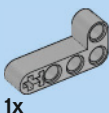
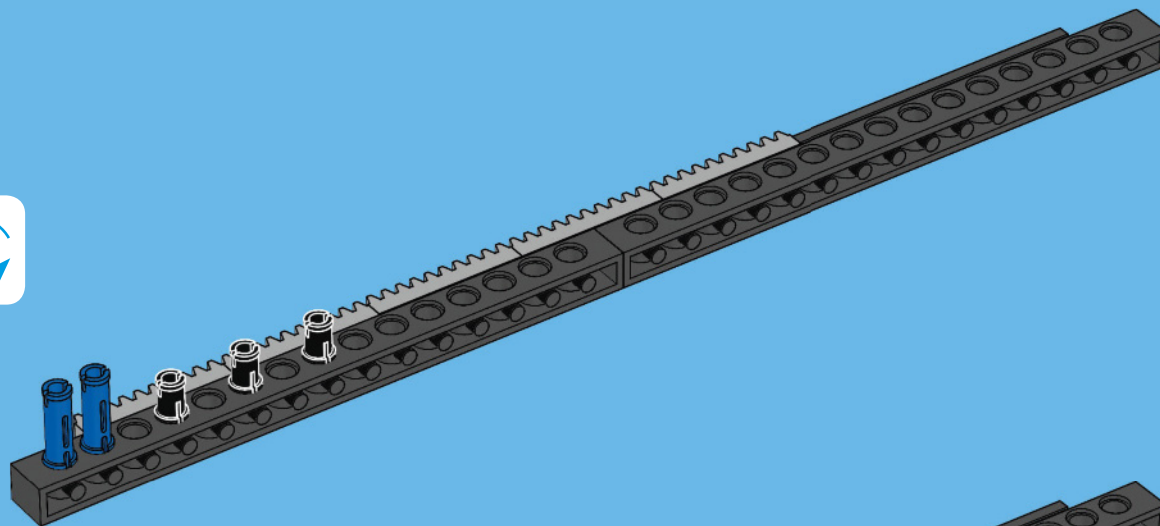

1x



1x

5

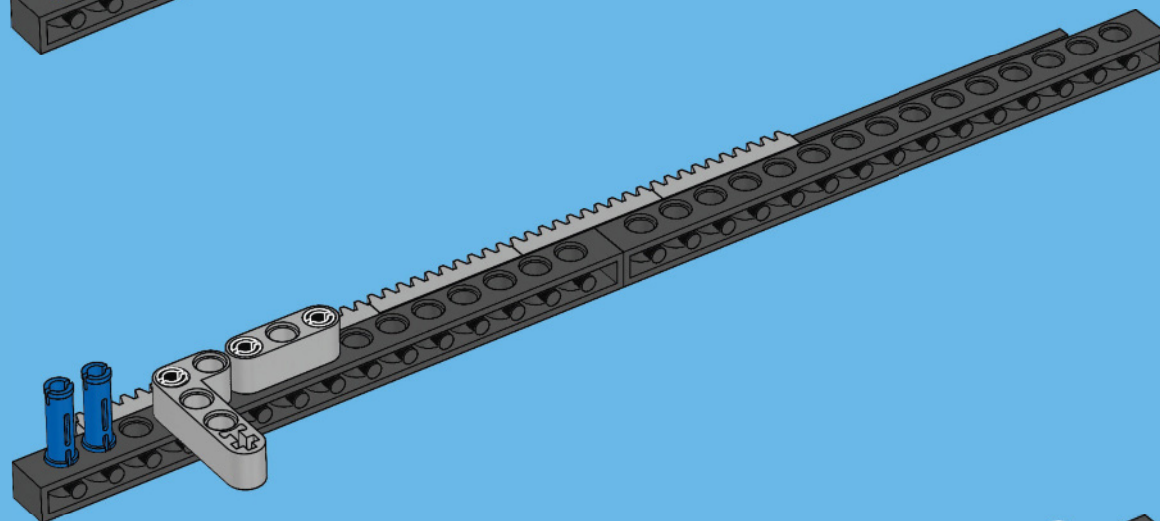

8x

6

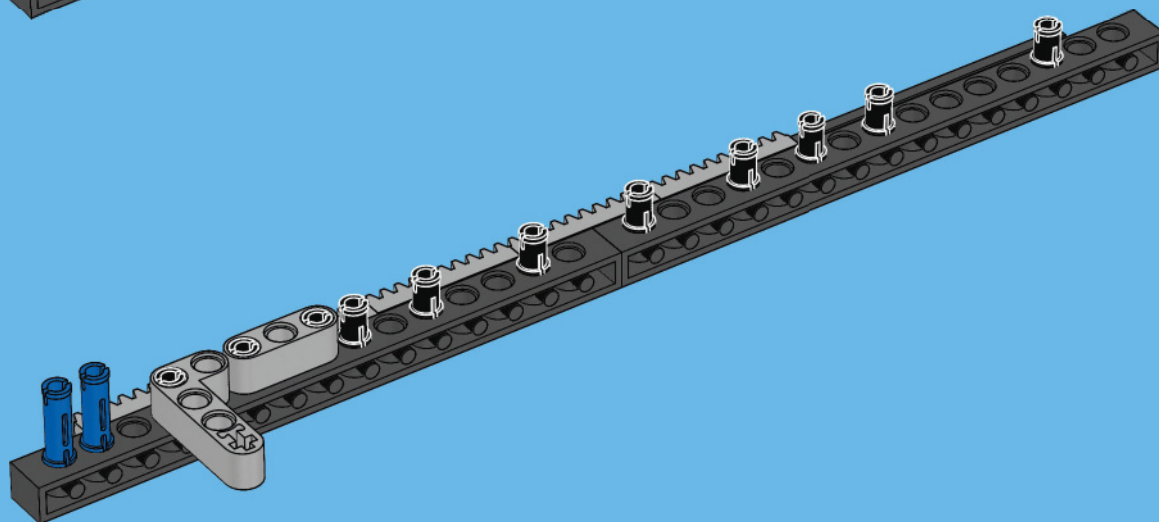



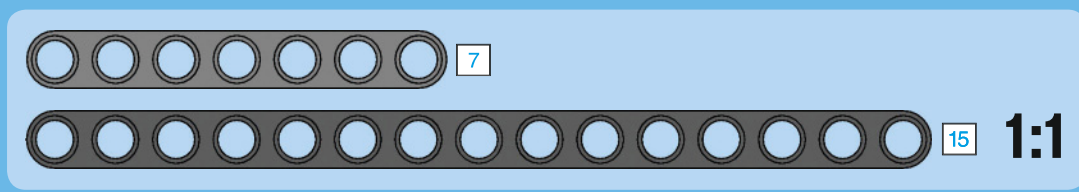
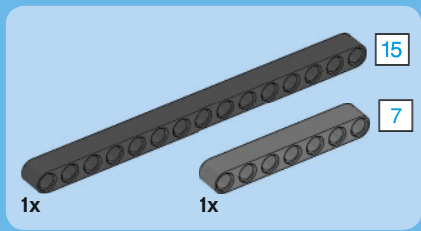

7

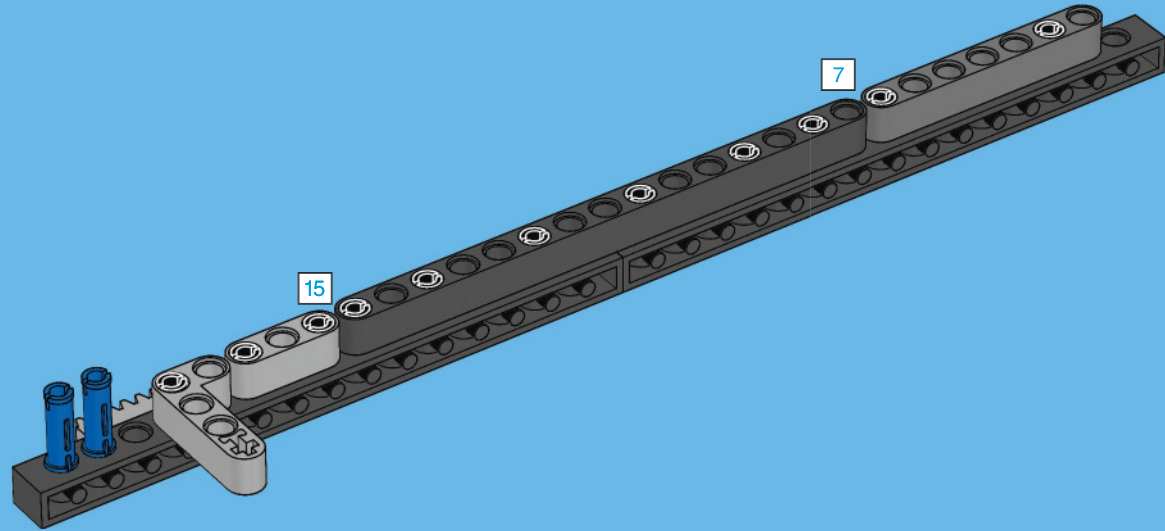

8

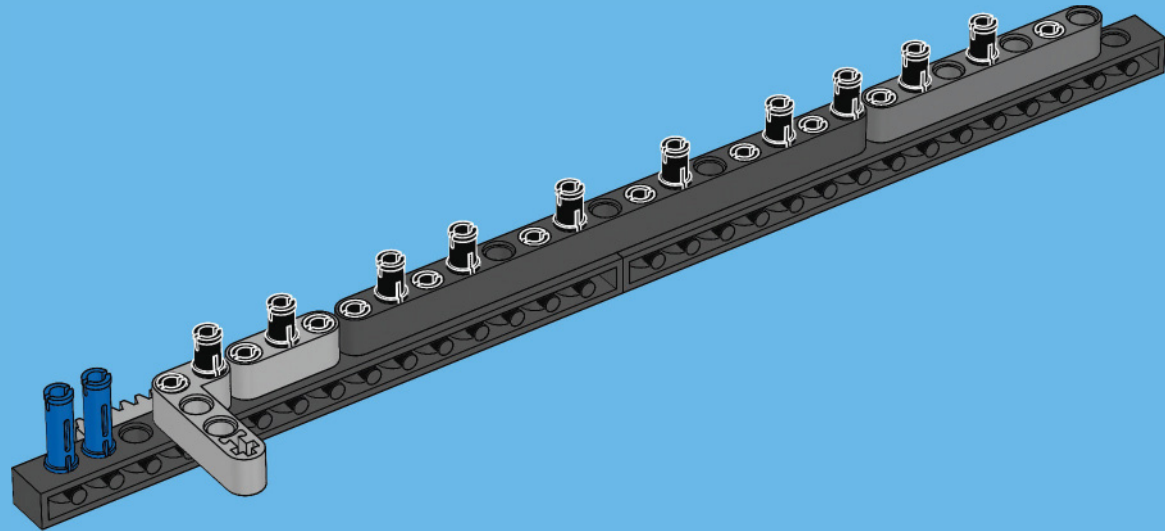

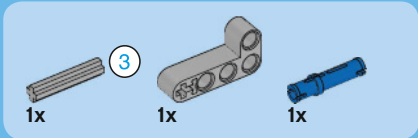
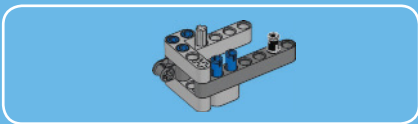

1

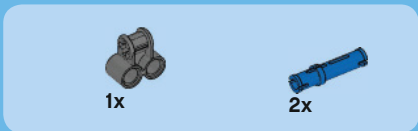
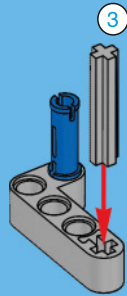

2

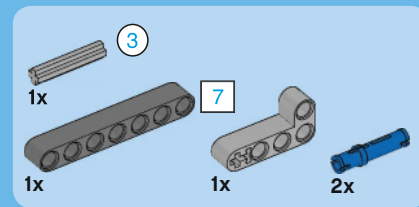
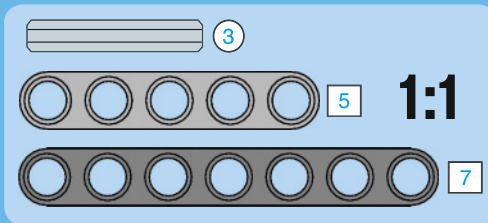
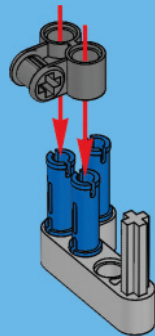

3

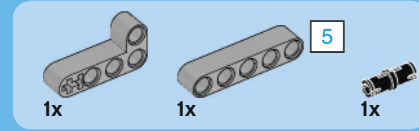
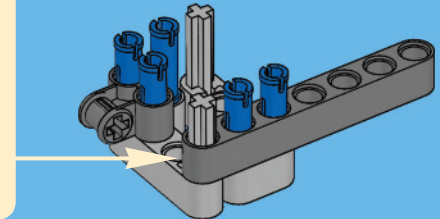
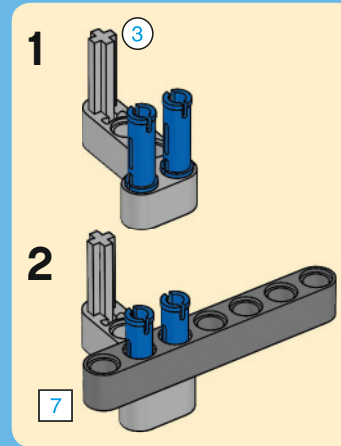

4

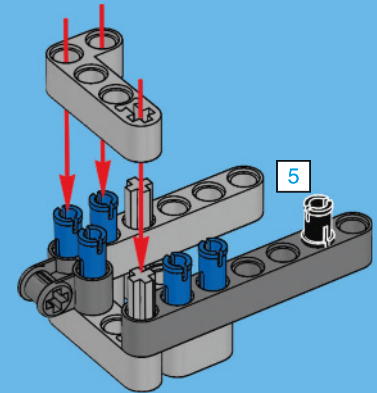



# 9

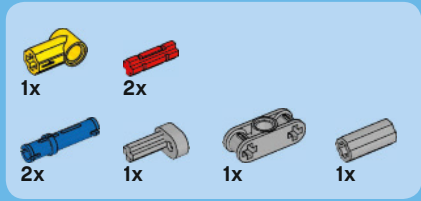
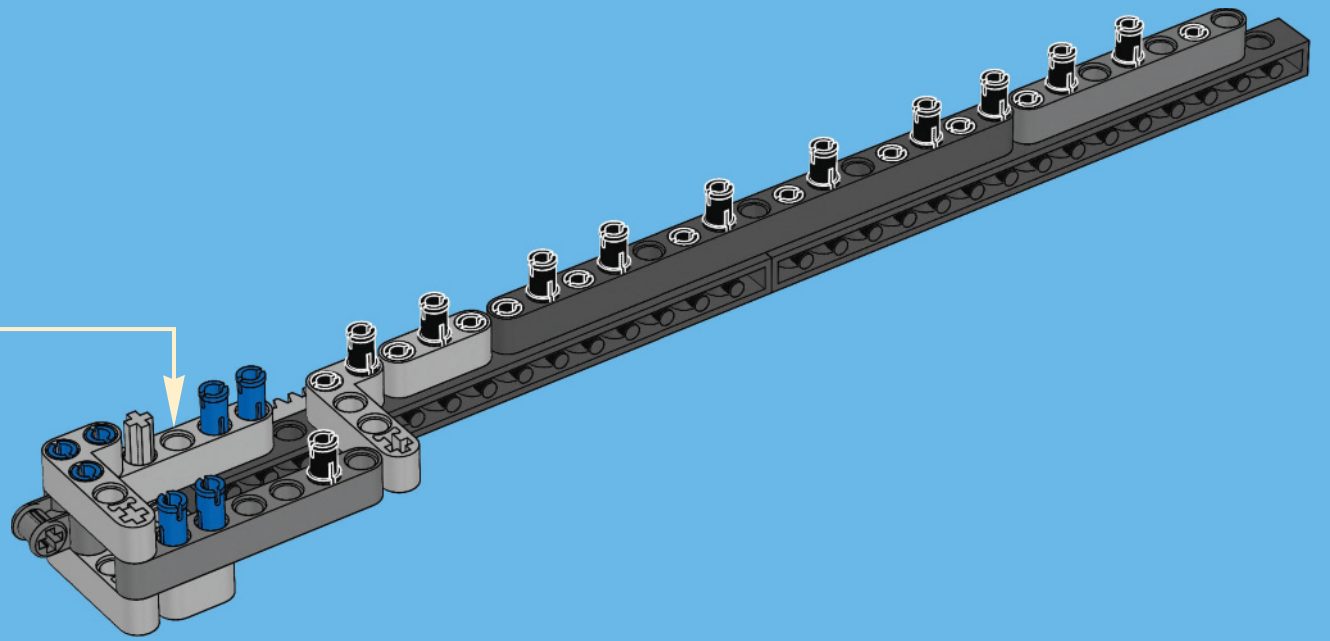

# 10

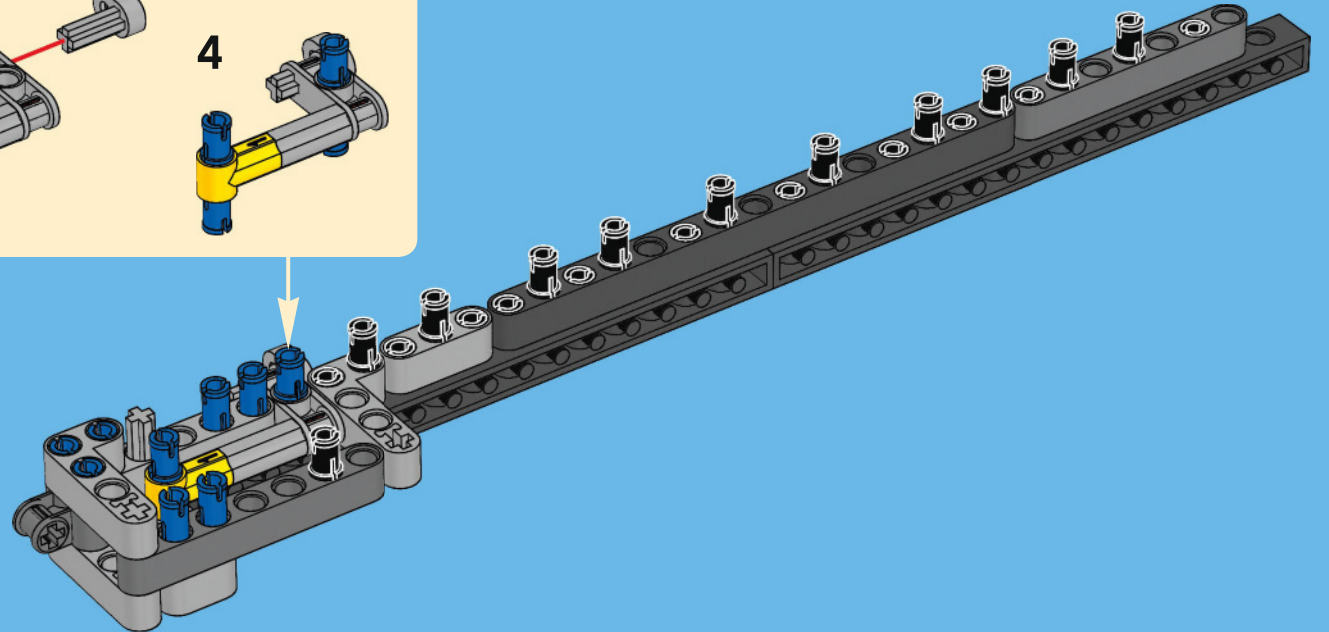
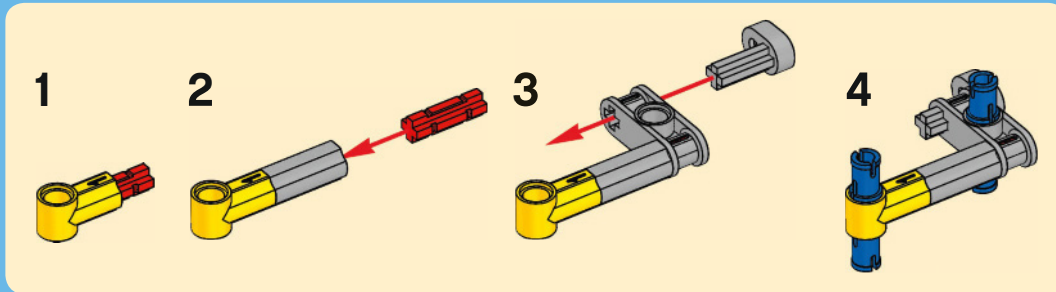

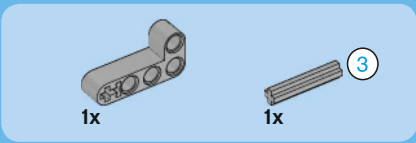

11

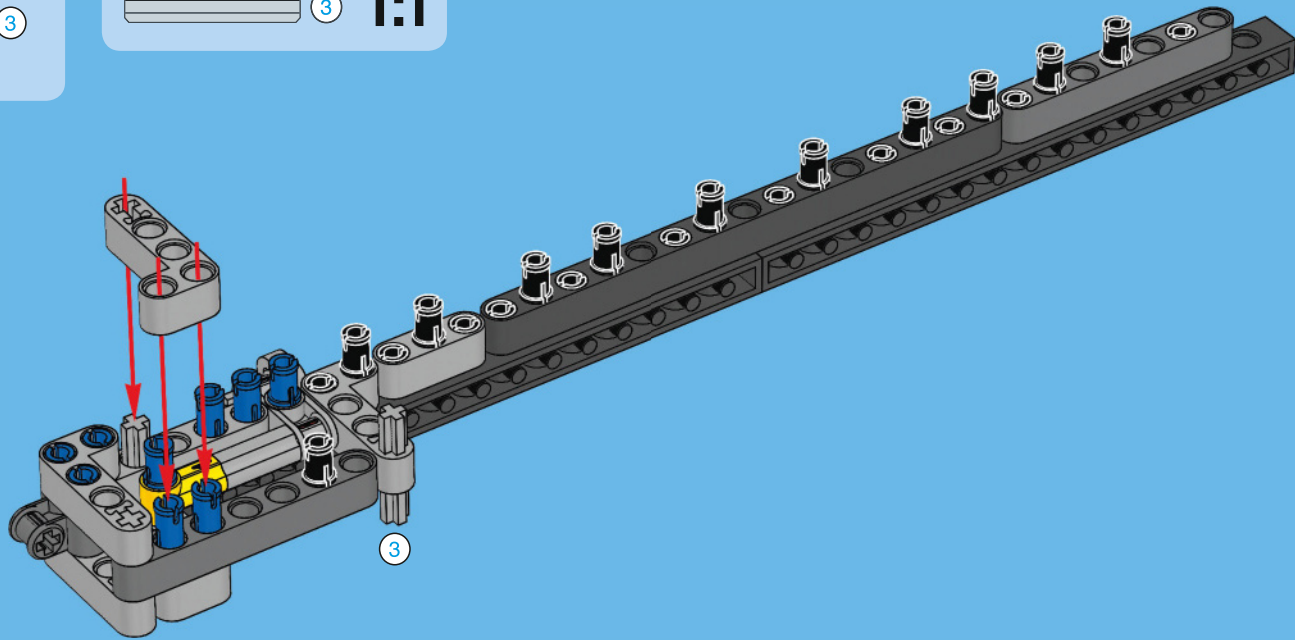

12

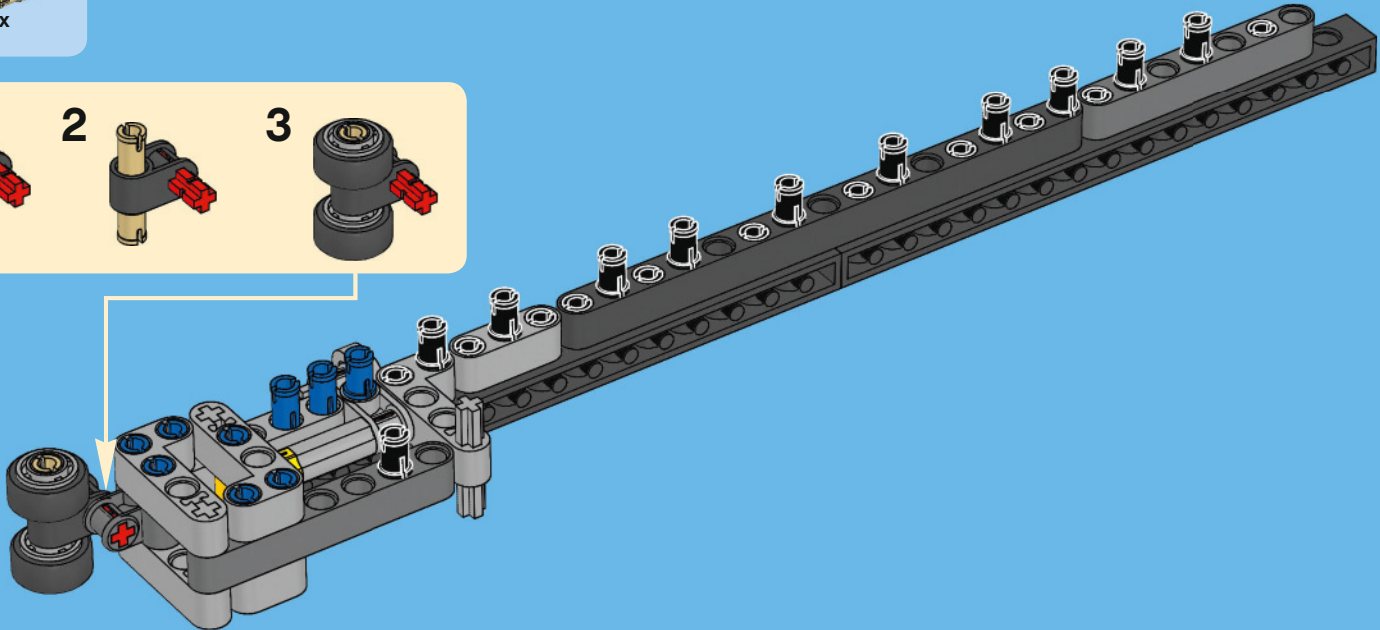
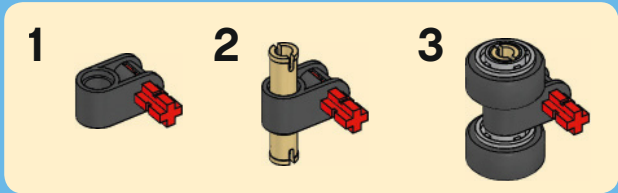



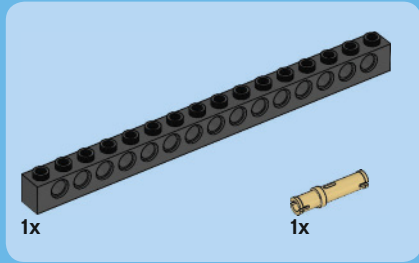
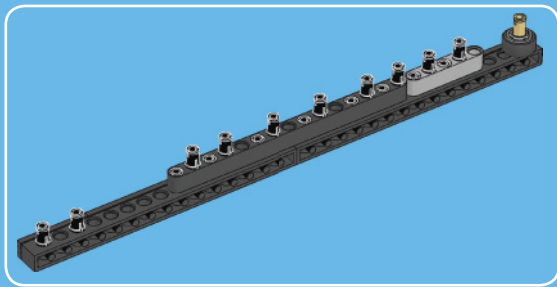

1

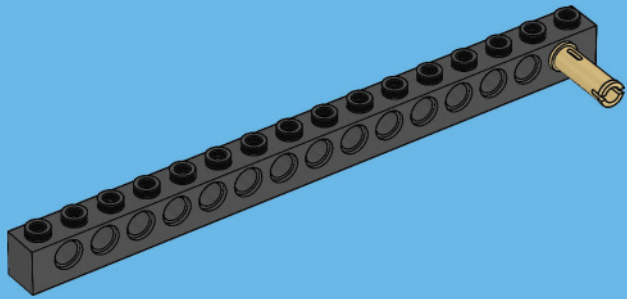

2

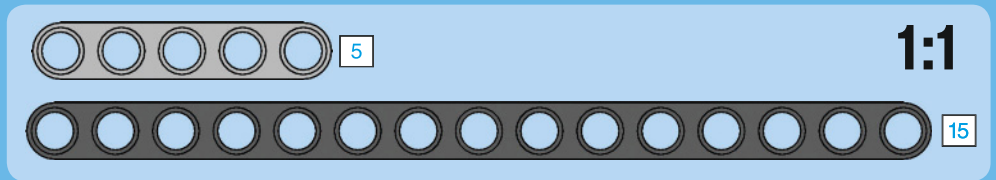
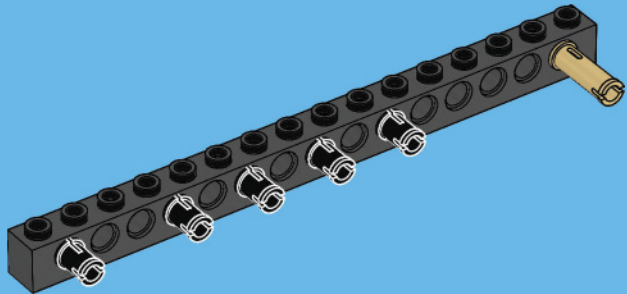

1:1

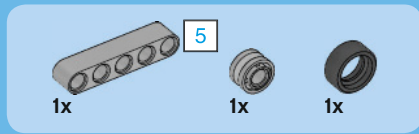

3

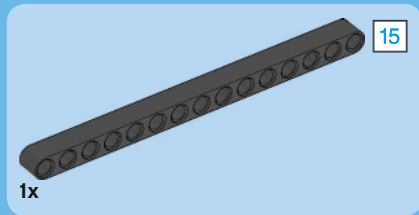
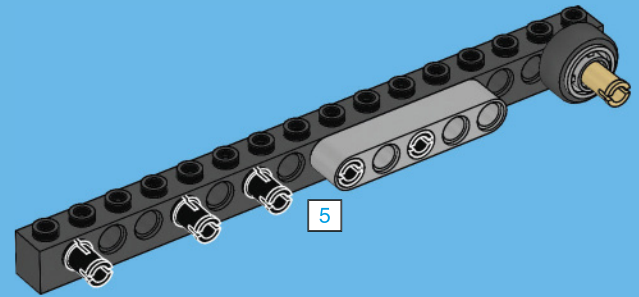

4

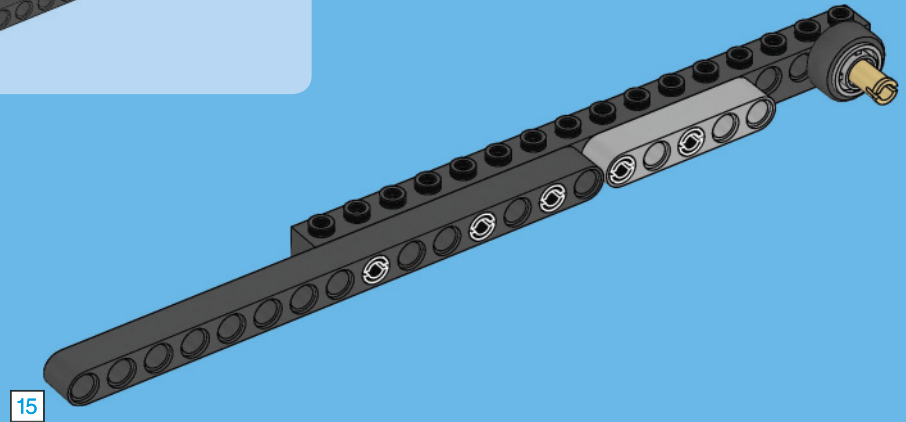

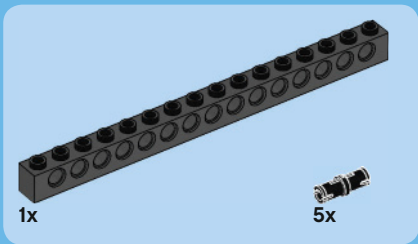

5

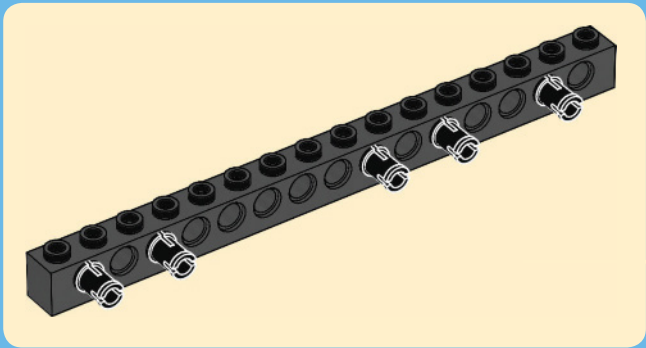

6

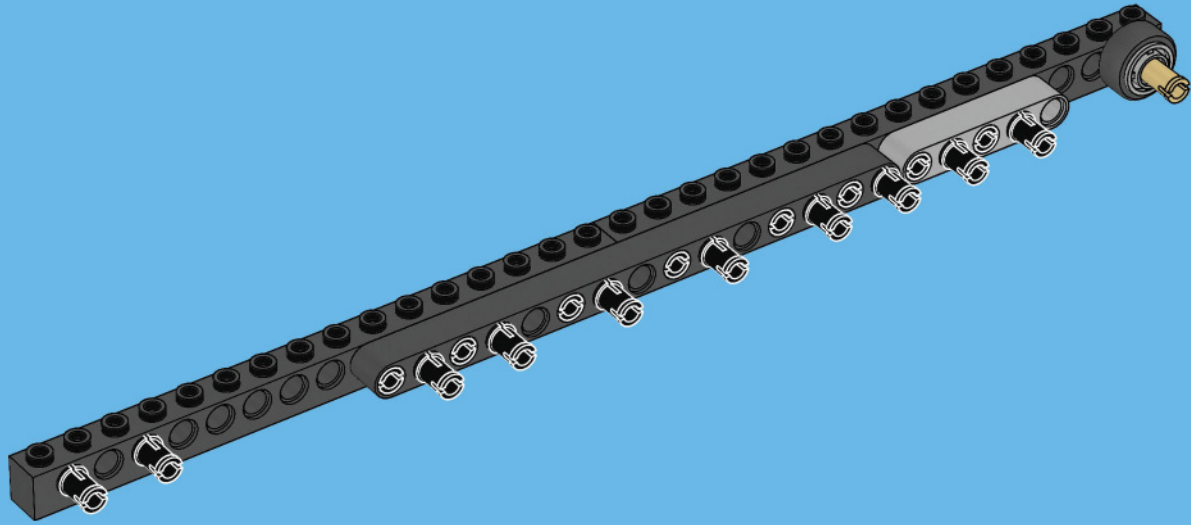



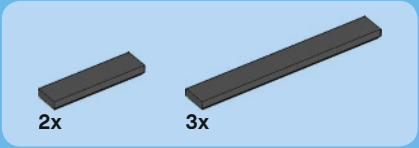

7

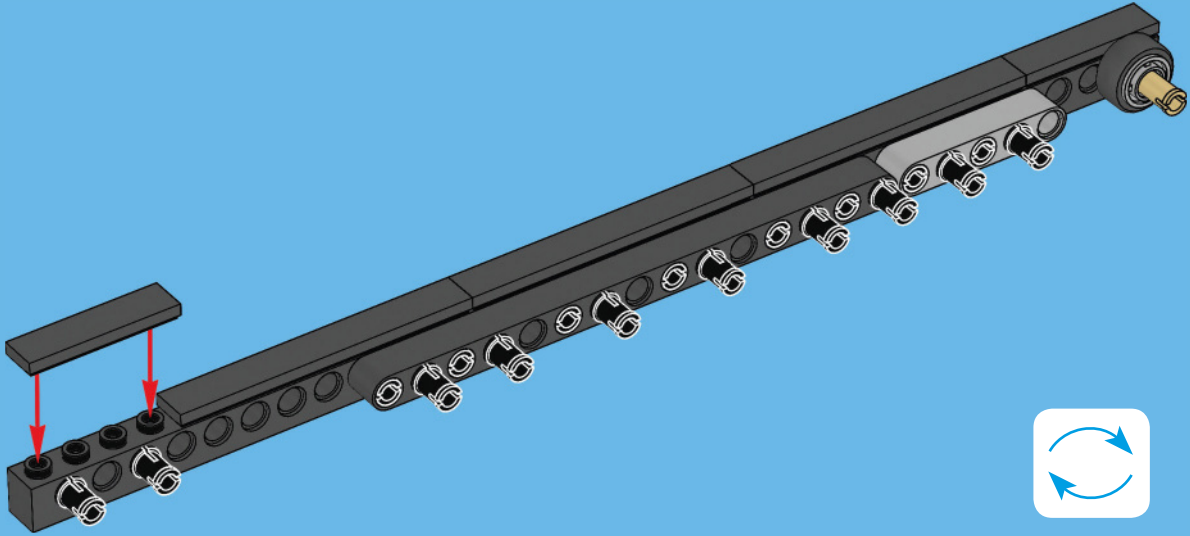

13

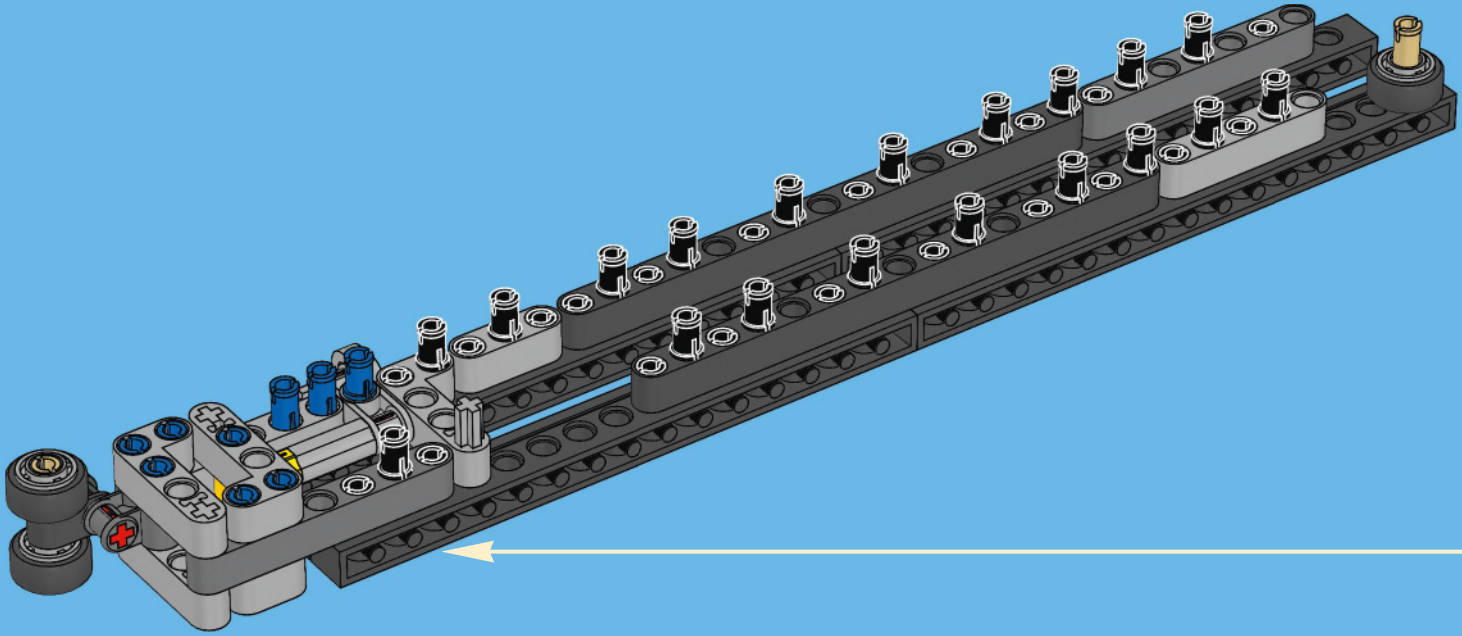

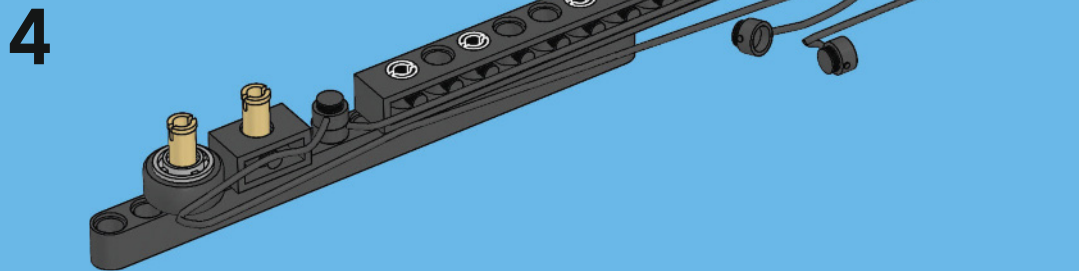
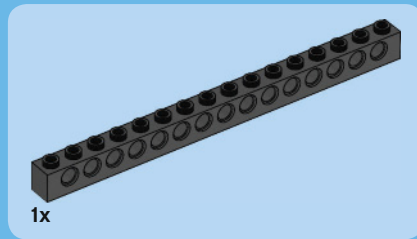
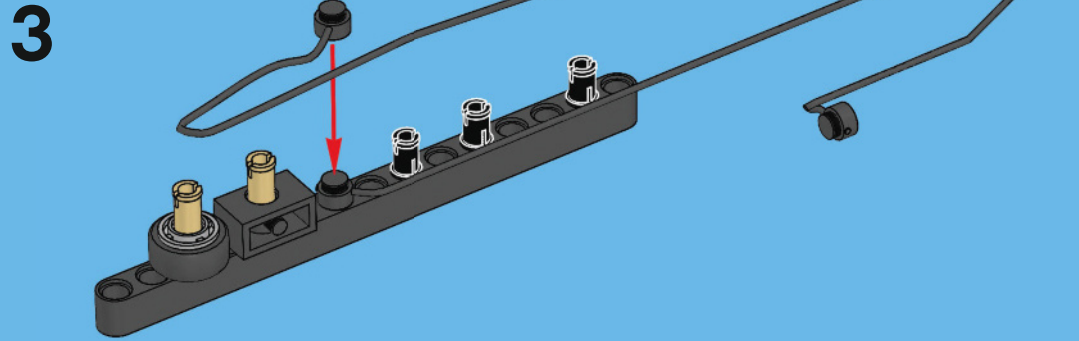
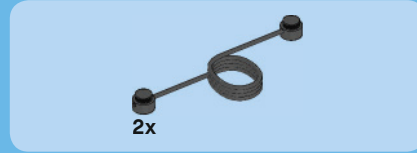
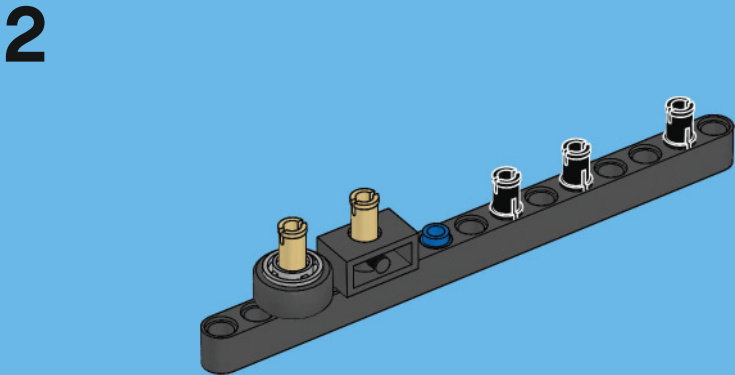
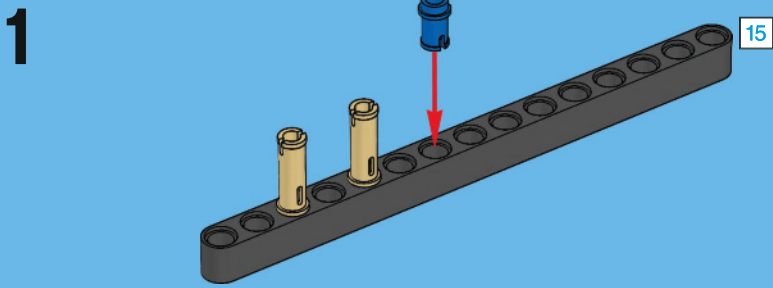
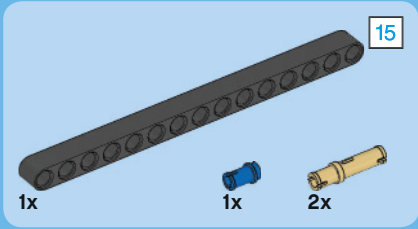
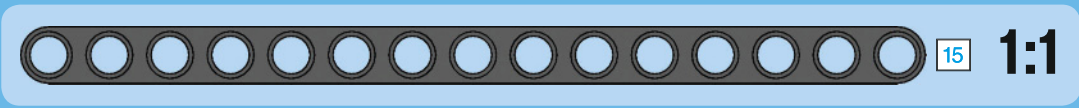
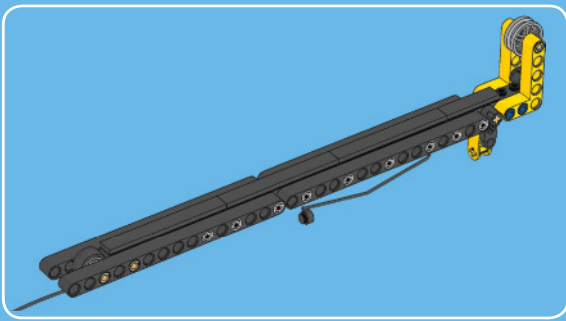





6x

5

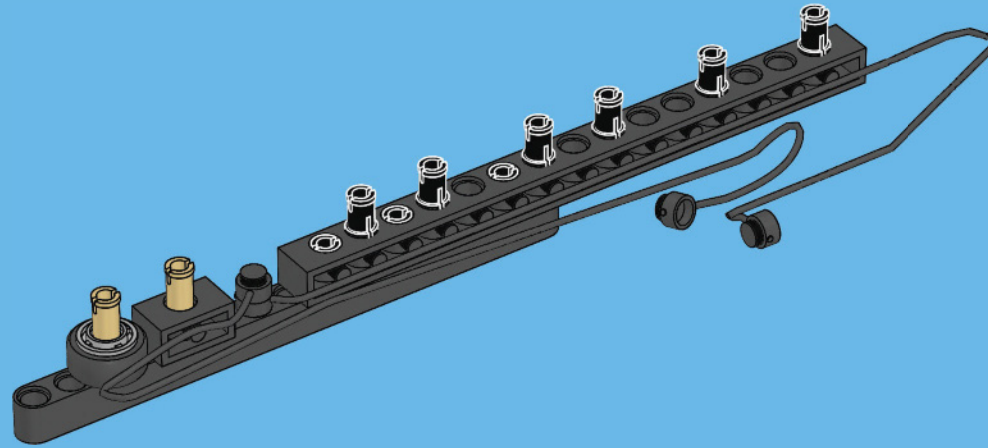

15

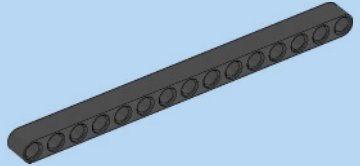

1x

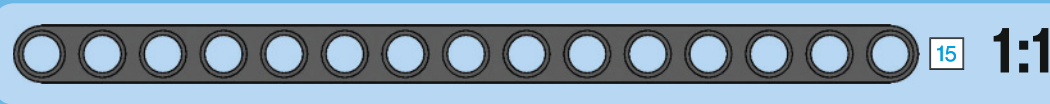

15

1:1

6

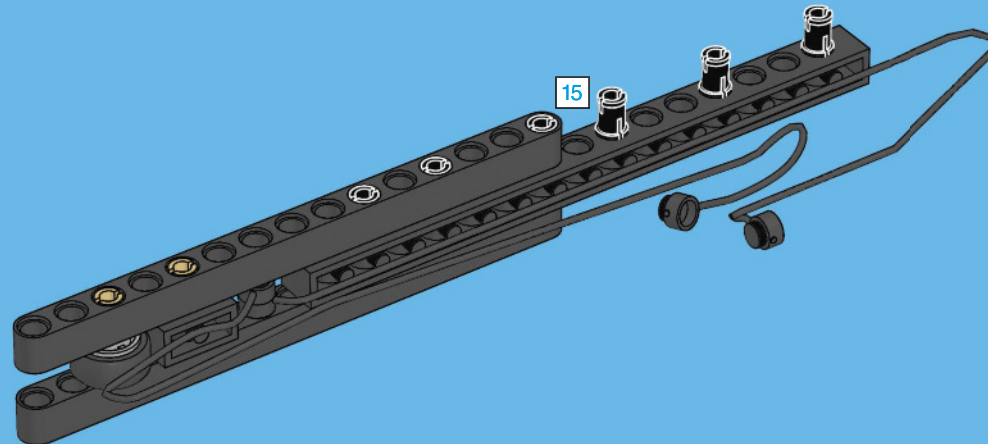

15

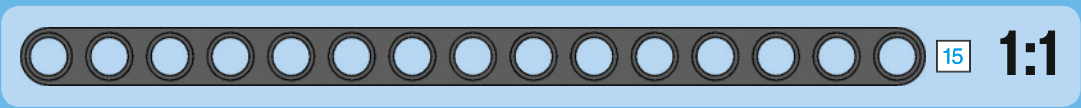
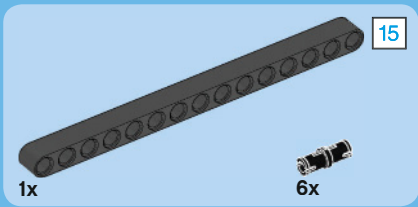

7

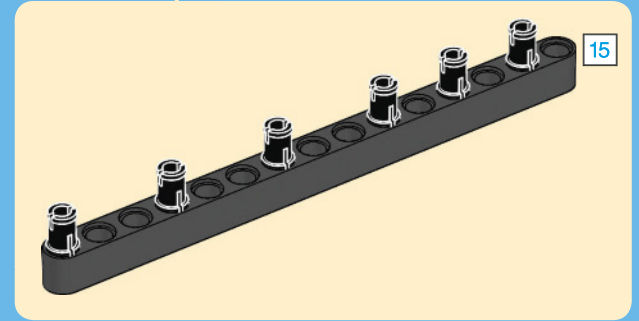
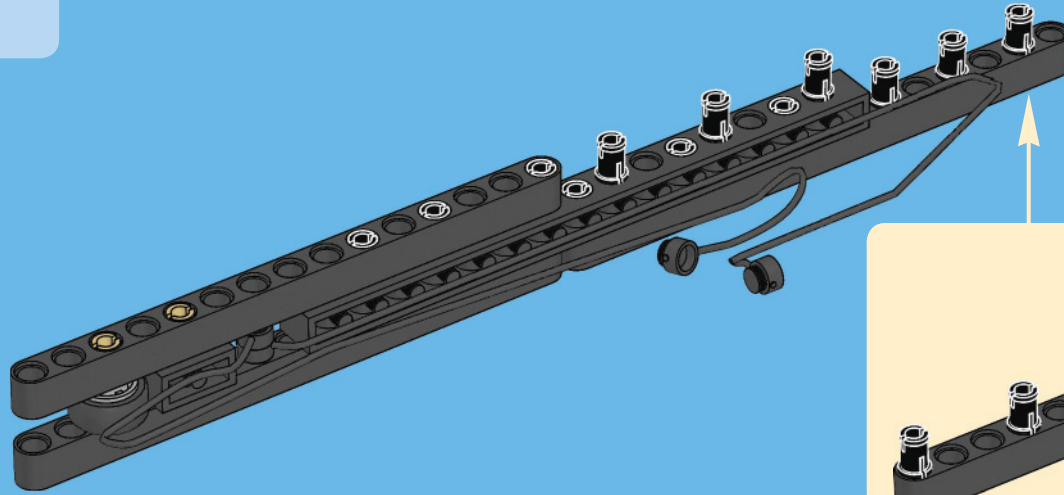

8

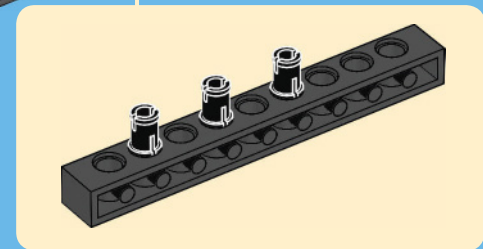
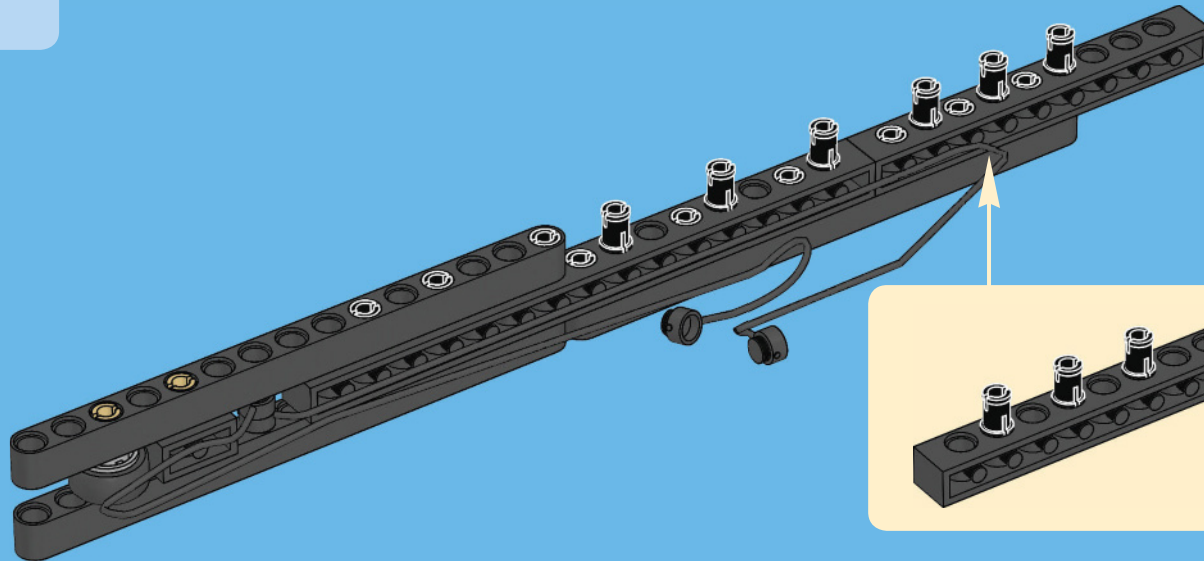



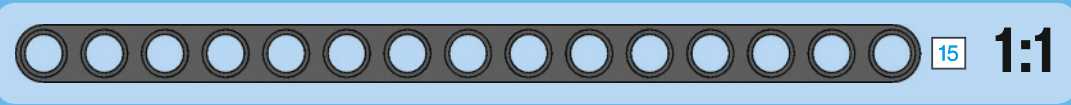
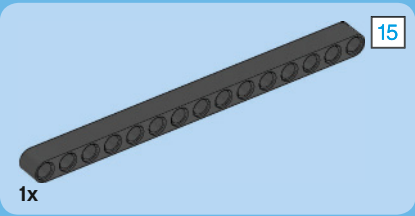

9



10

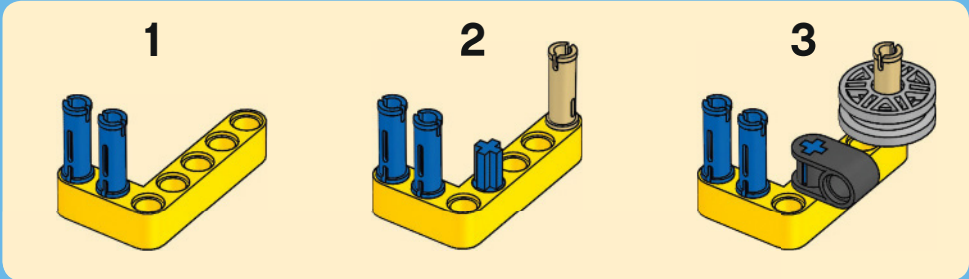



# 11

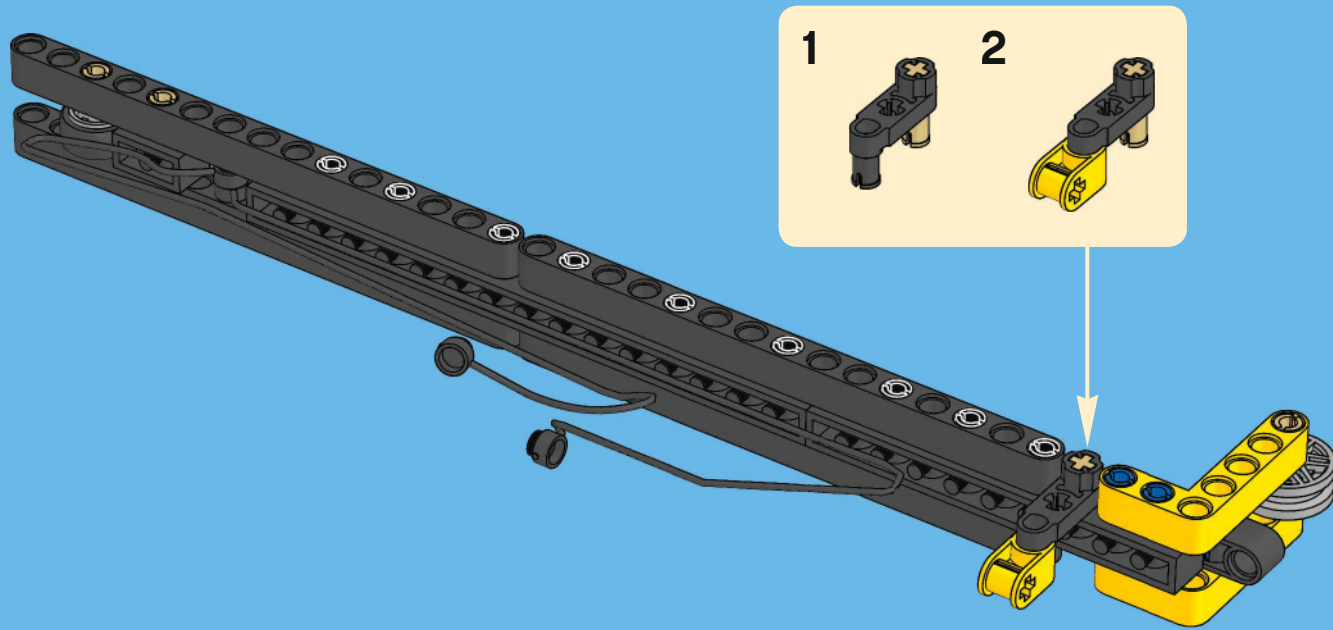



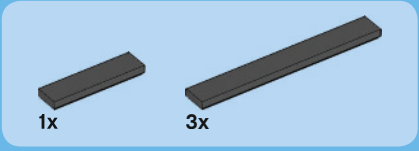

12



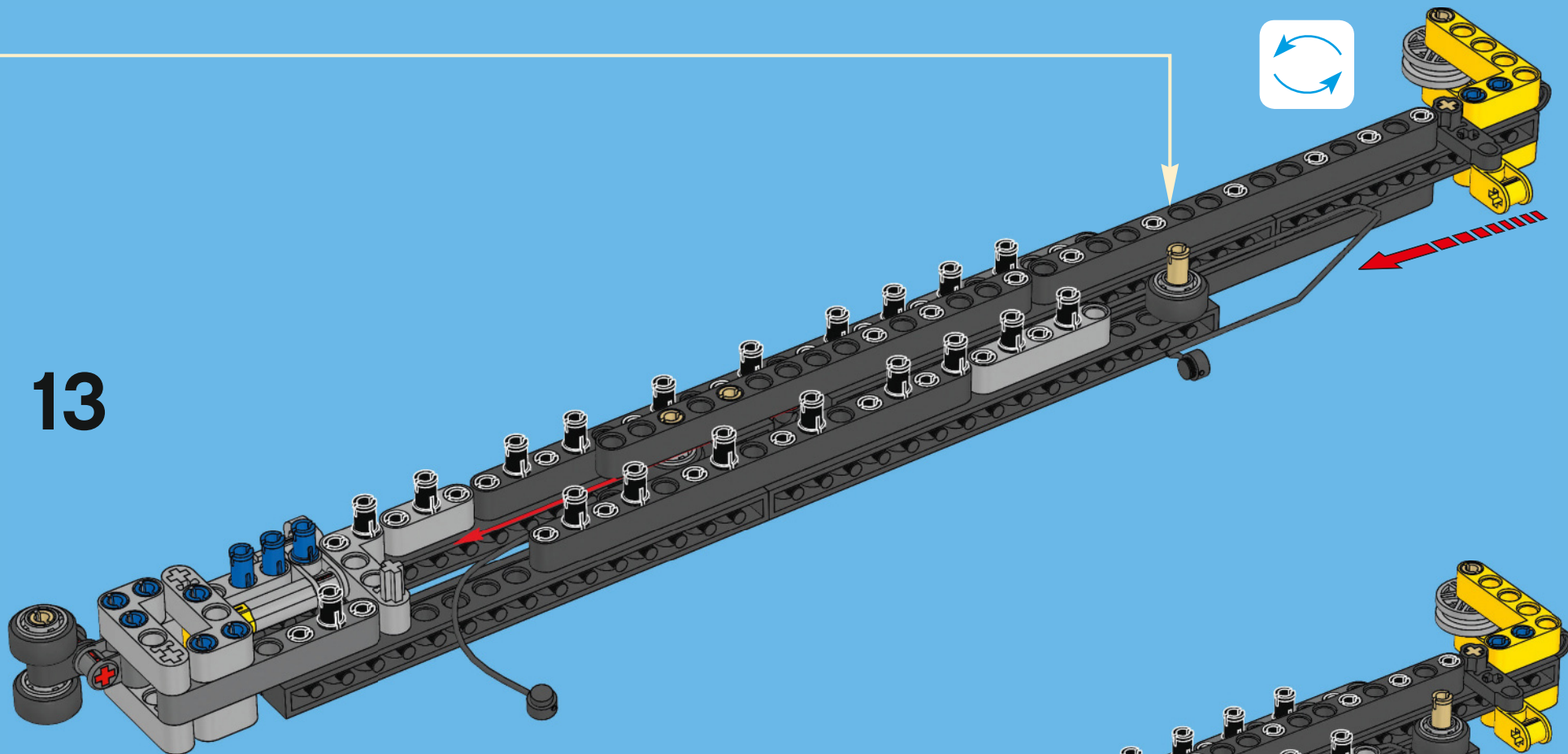

13

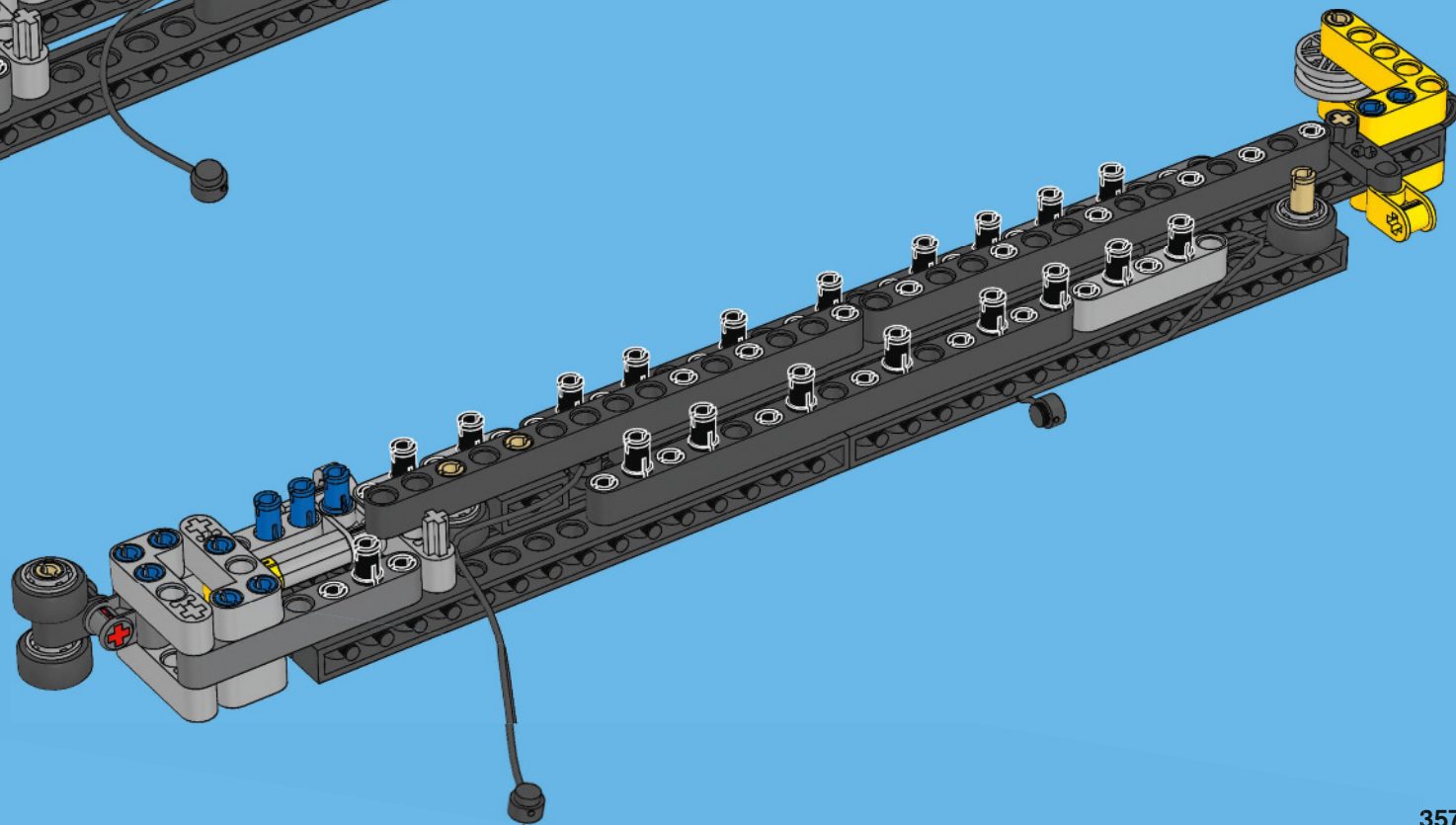

14



2x  2x  ③

 ③ 1:1

15

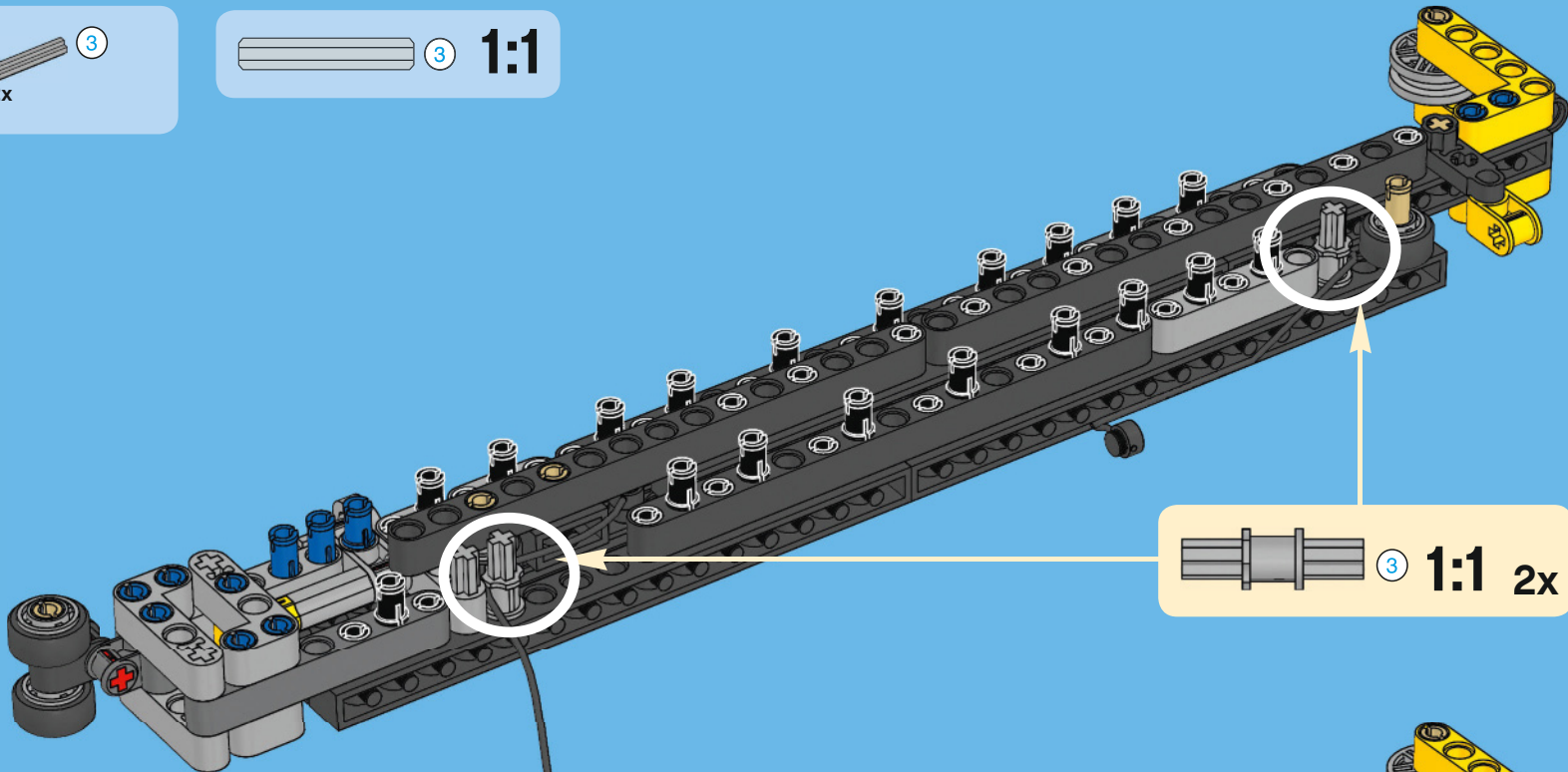

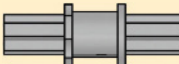
 ③ 1:1 2x

16

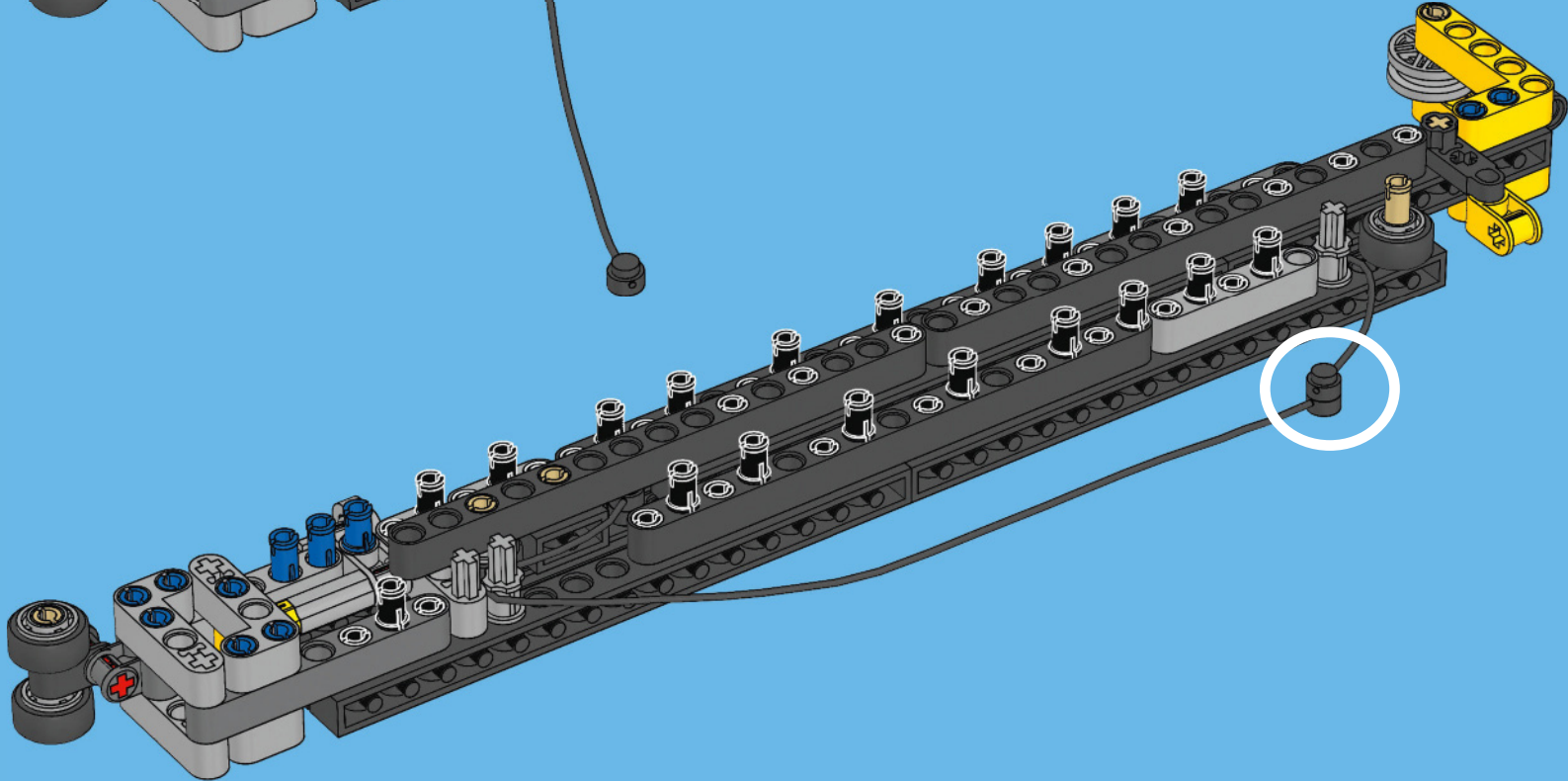

 ③ 1:1 2x



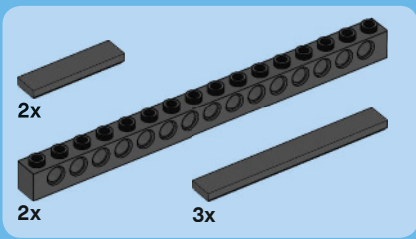

17

1

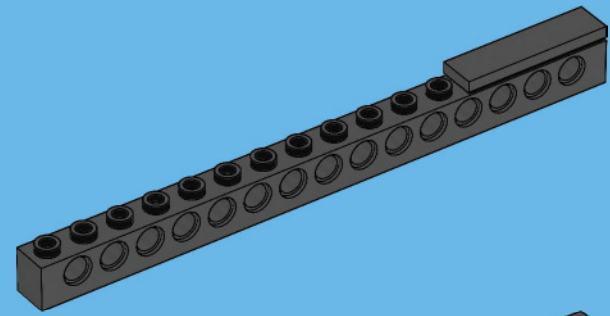

2

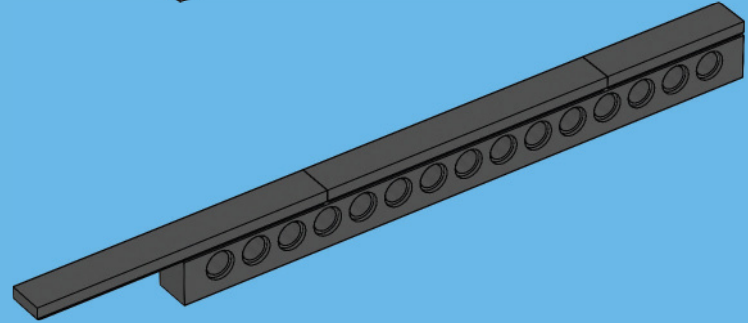

3

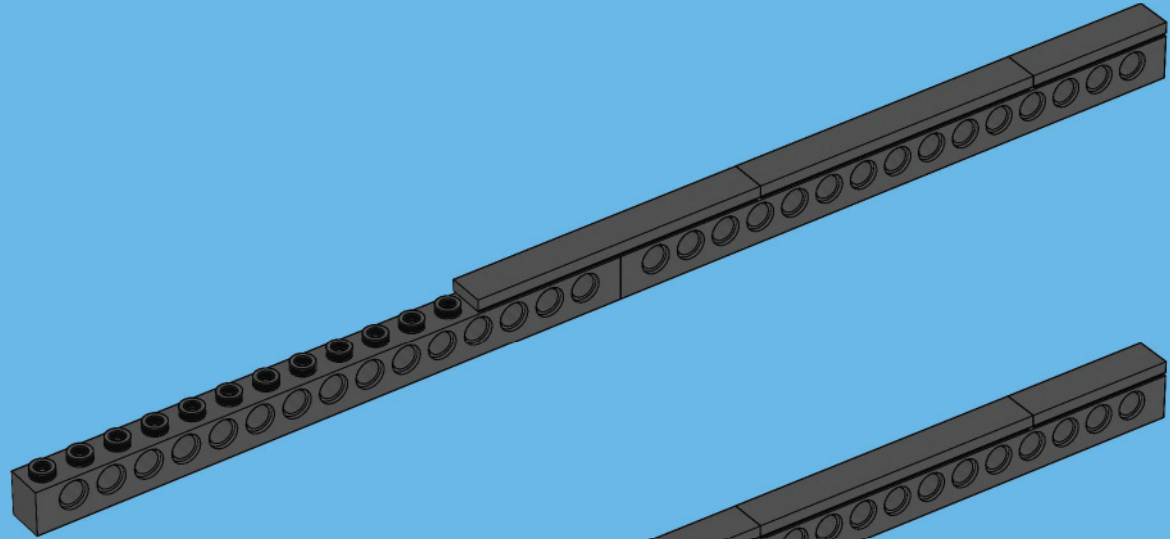

4

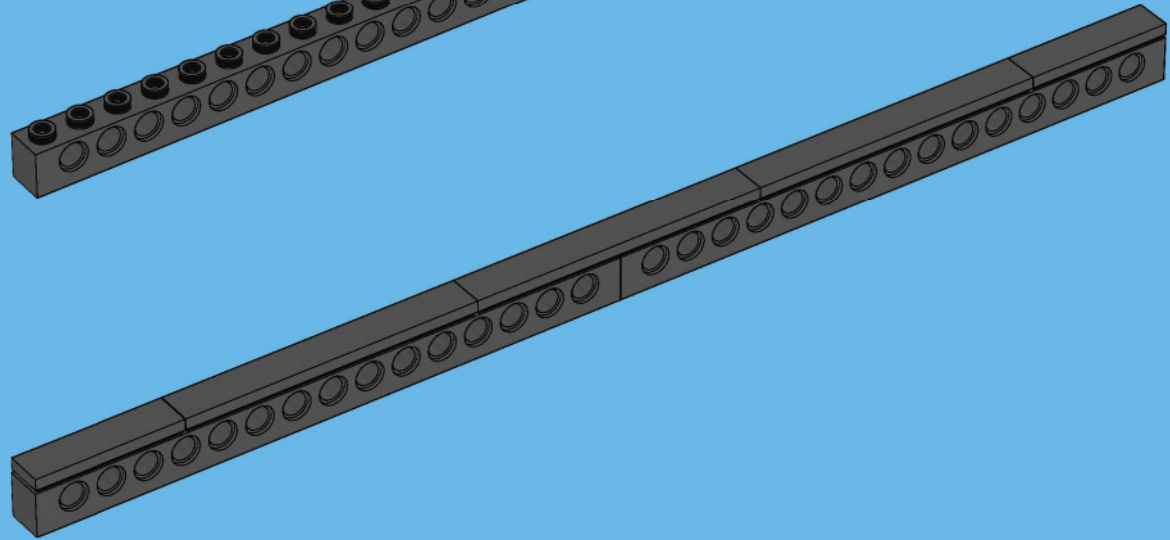

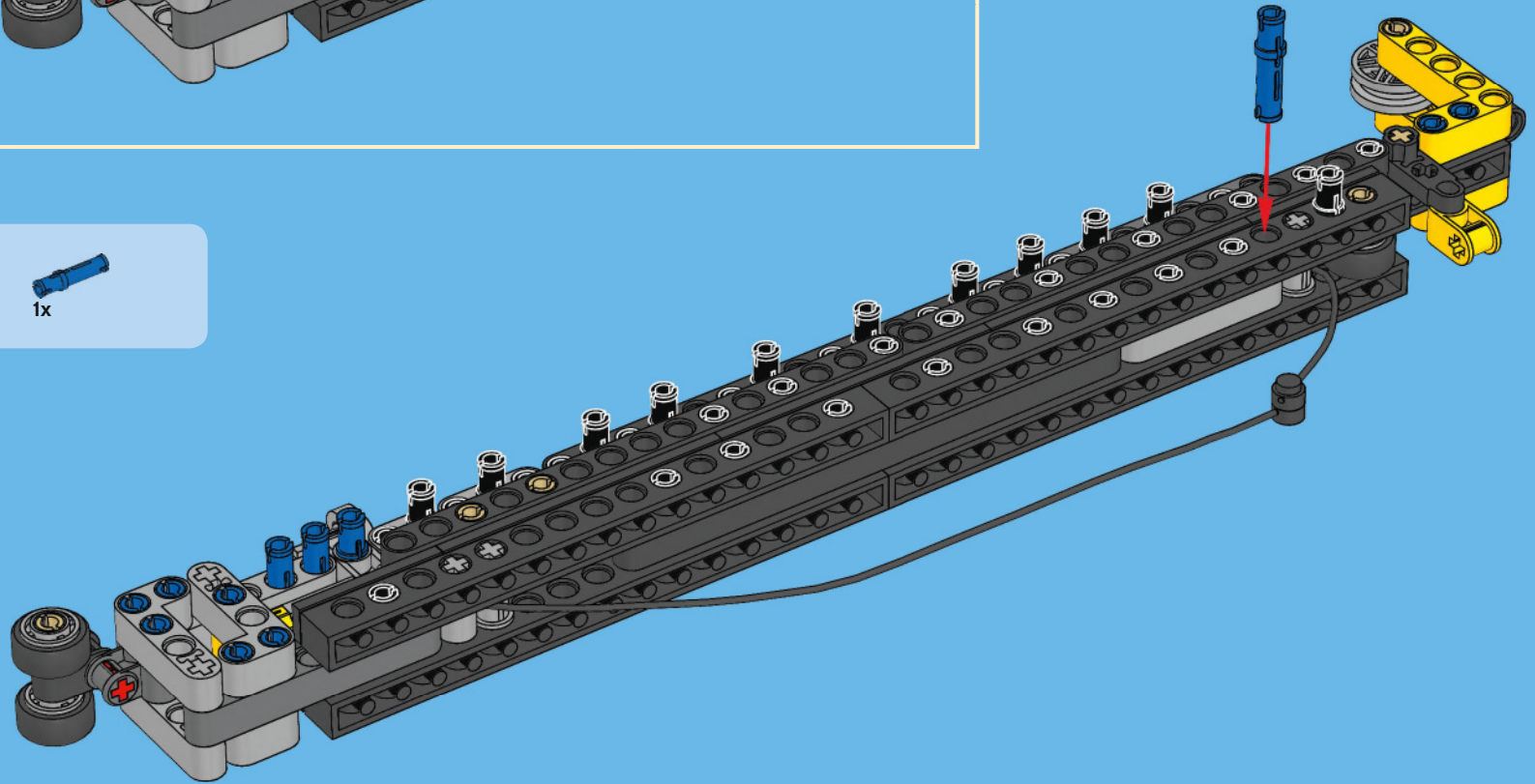
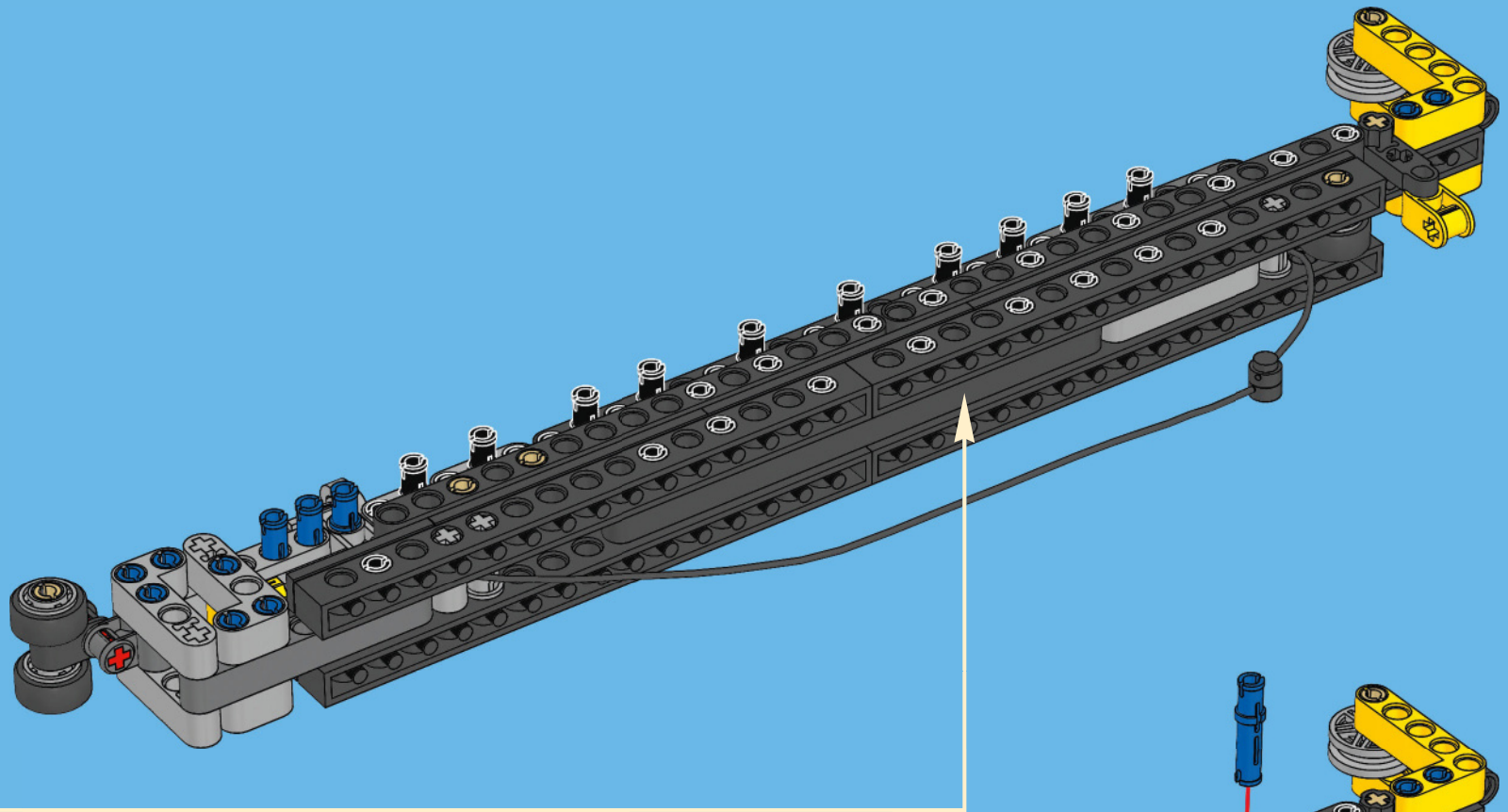

18

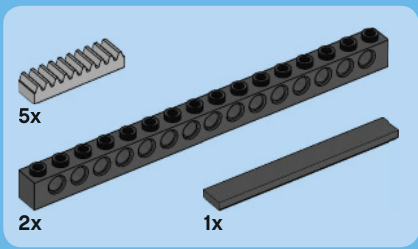

19

1

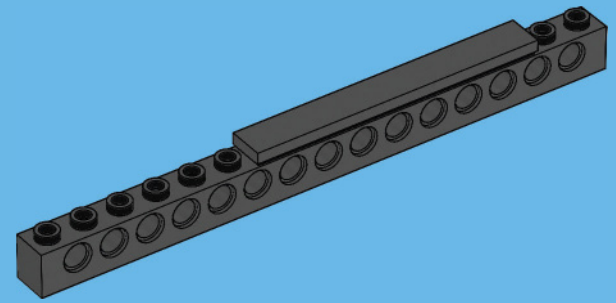

2

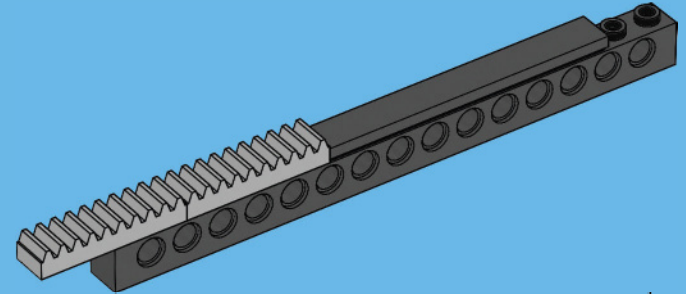

3

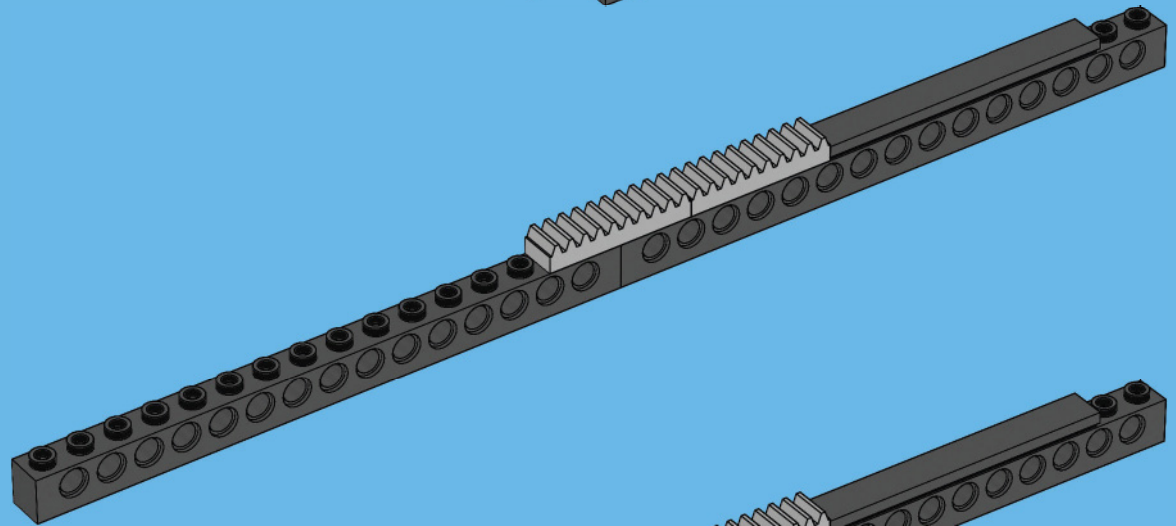

4

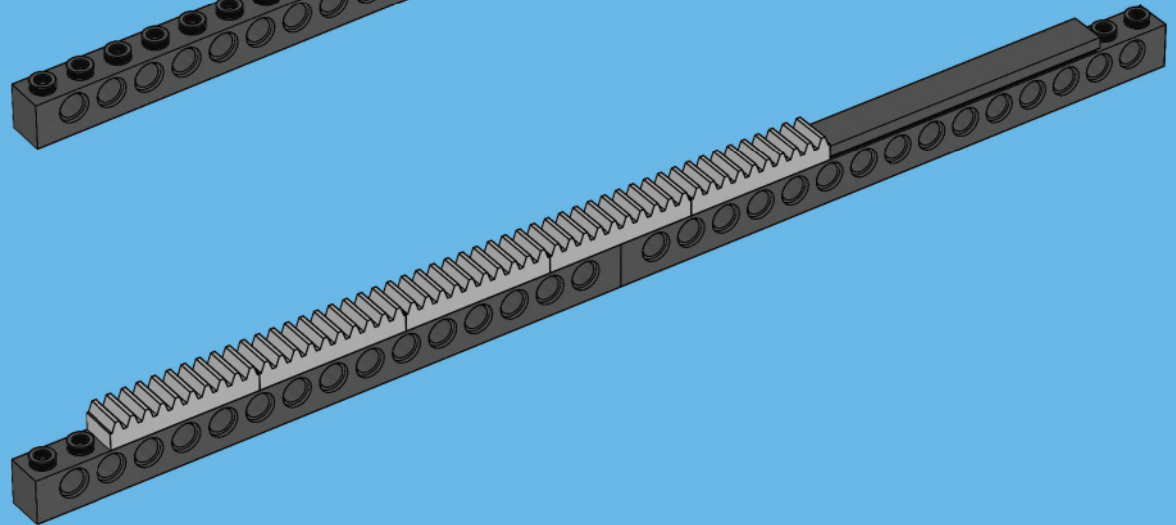



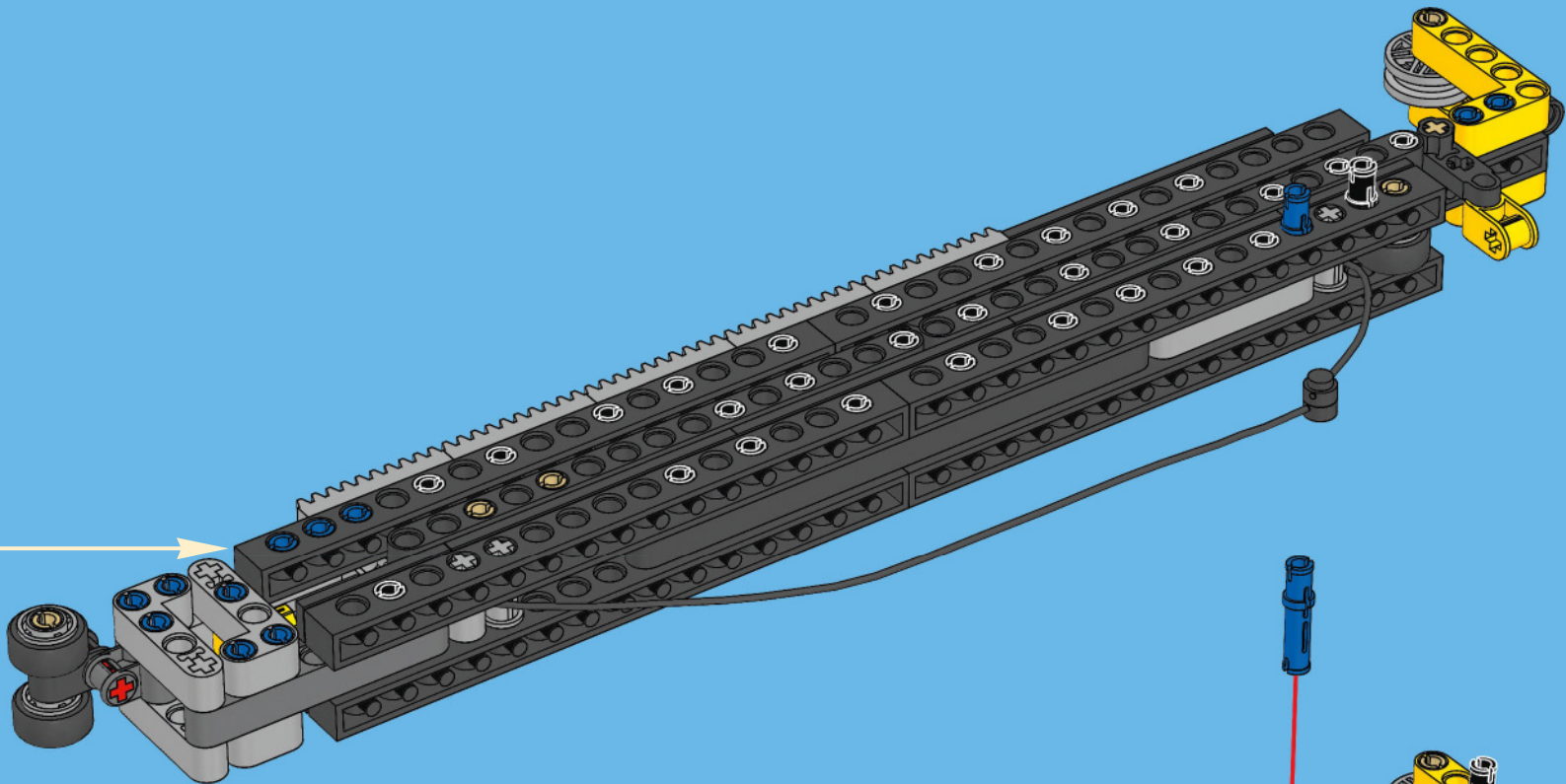

20

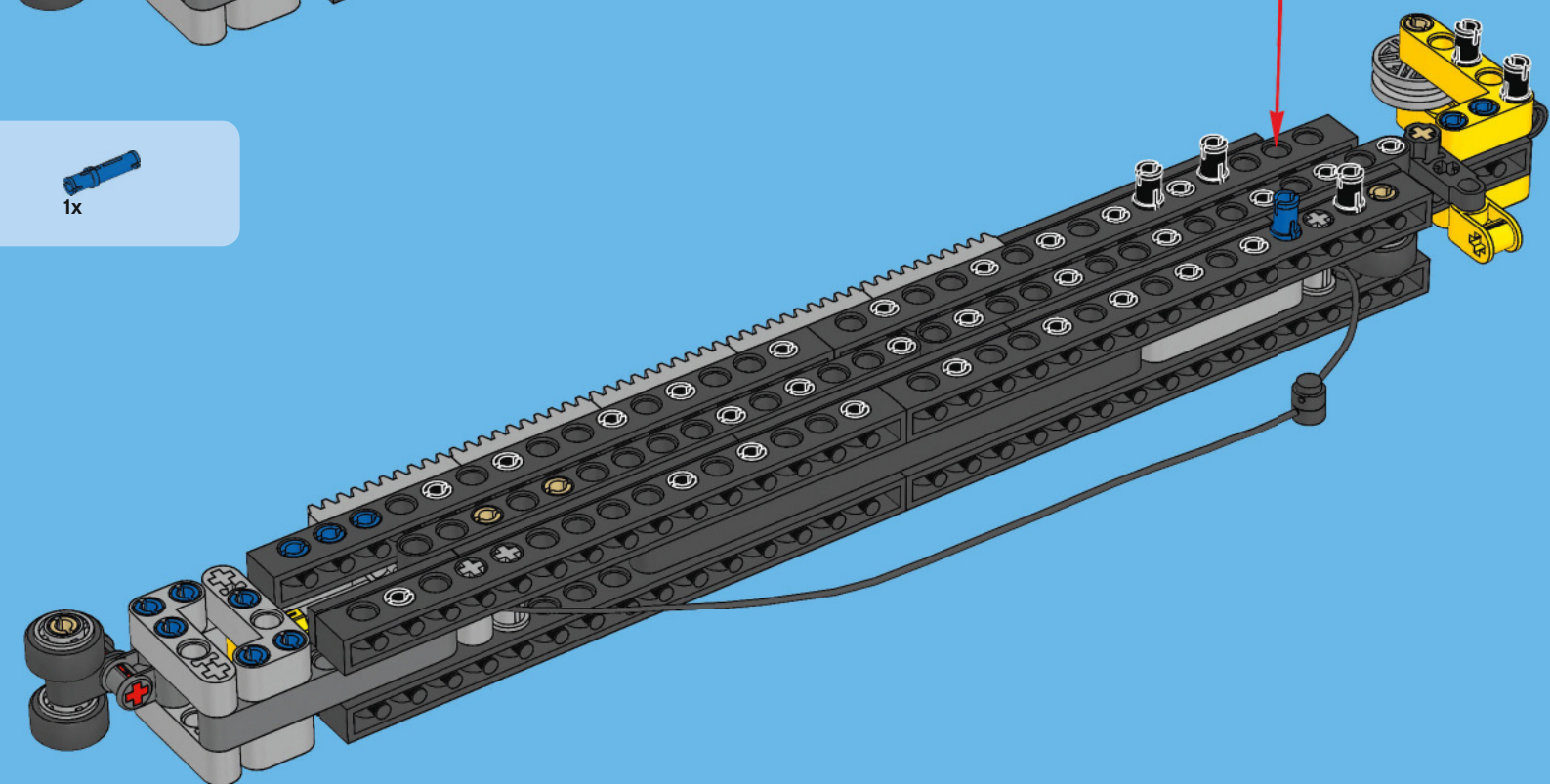



2x

21

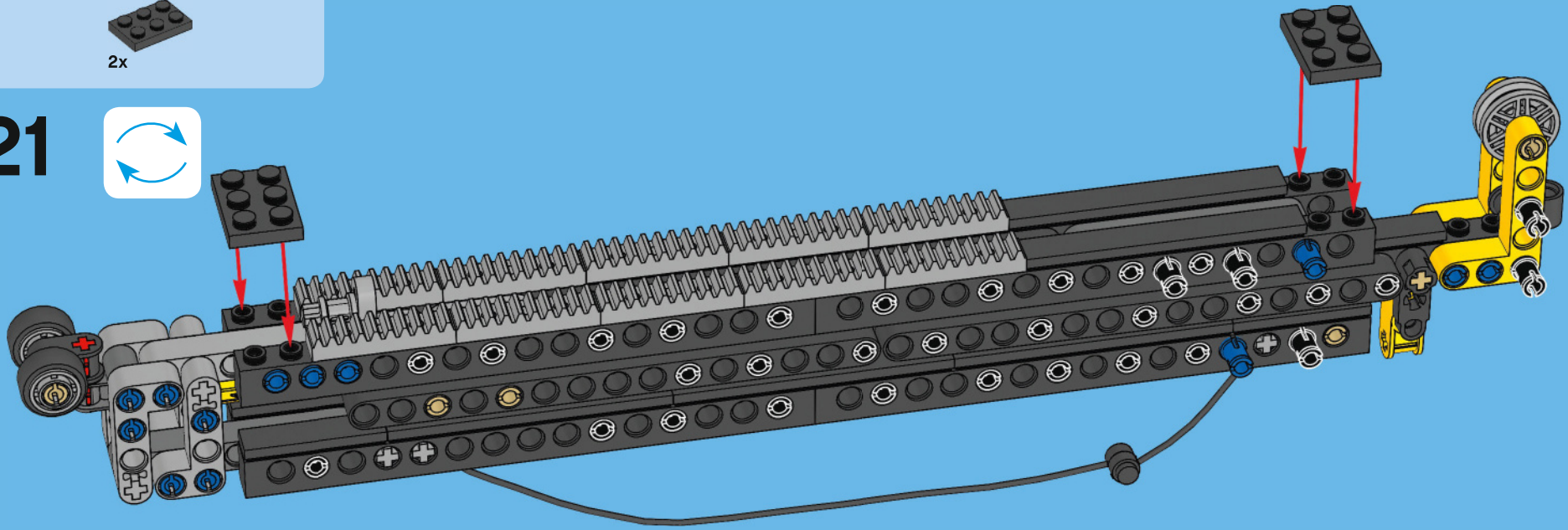

7x

22

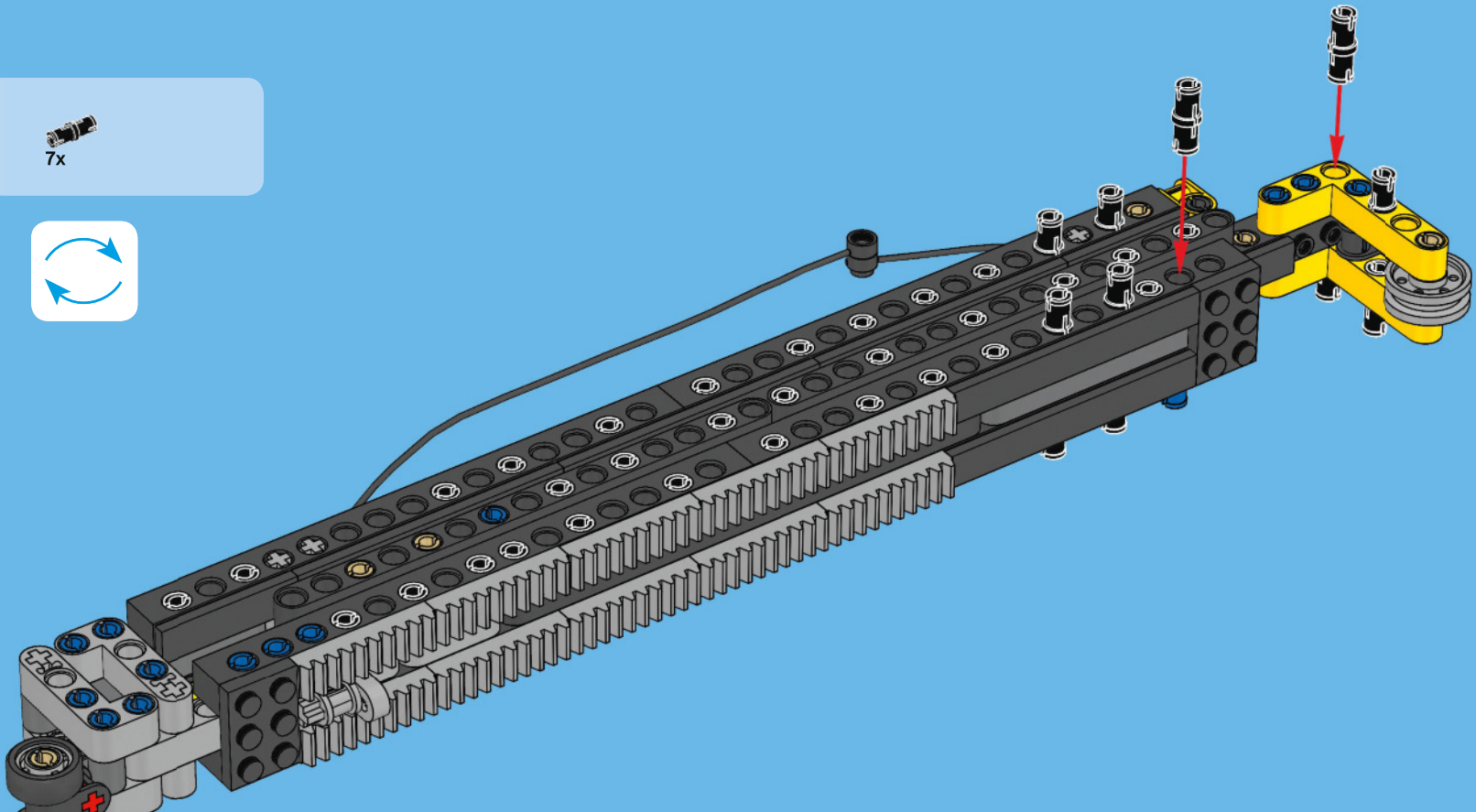

# 23

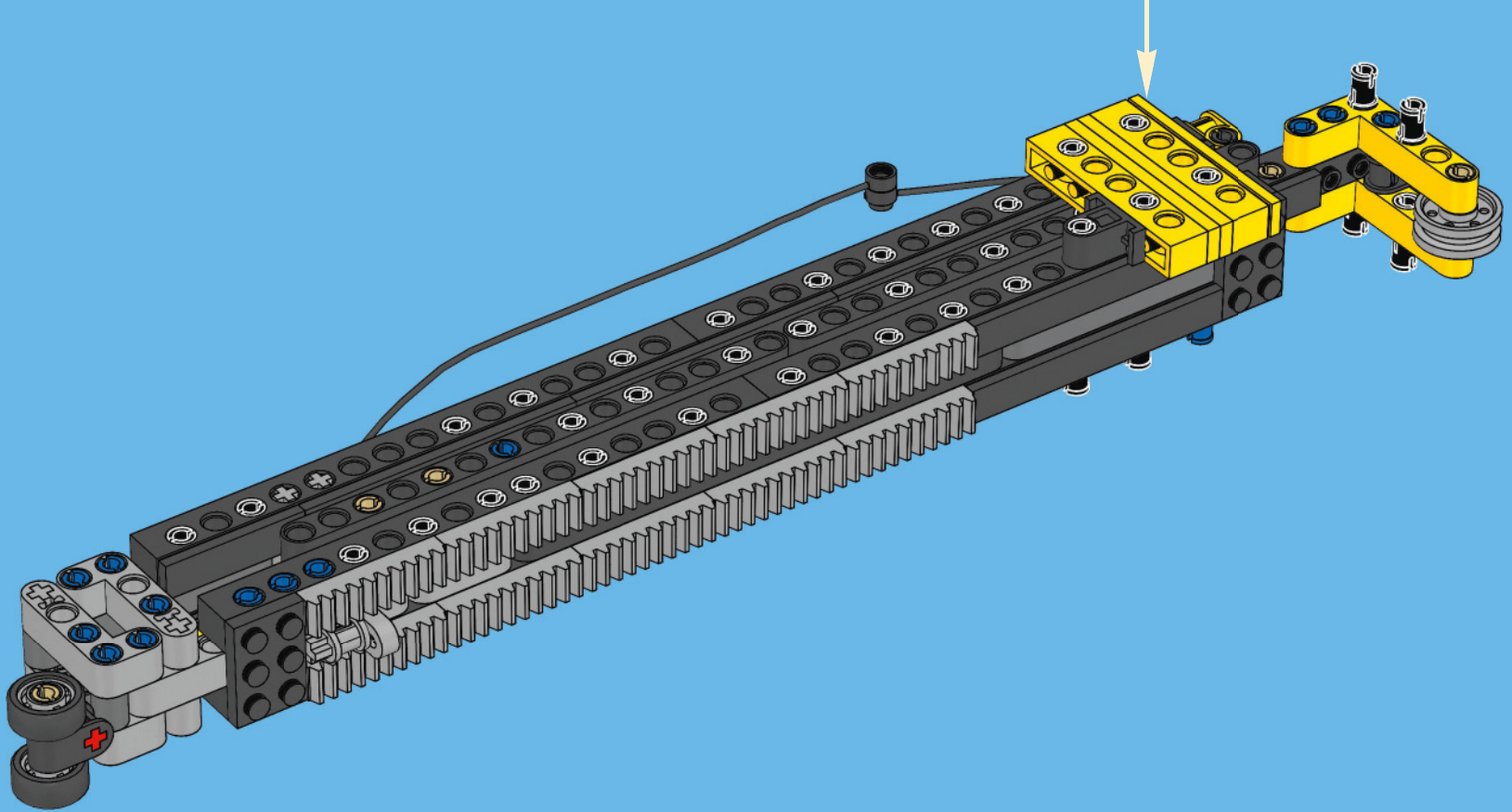
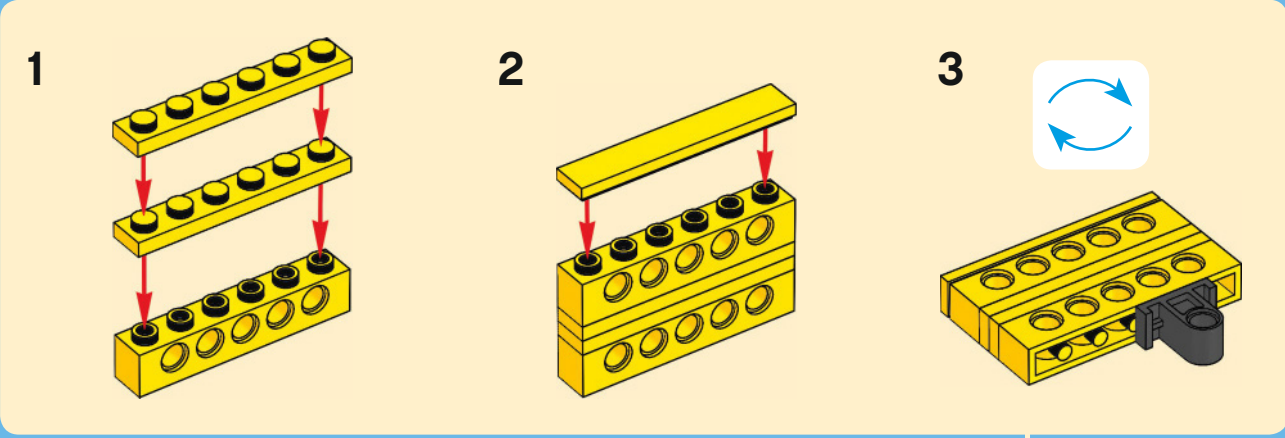
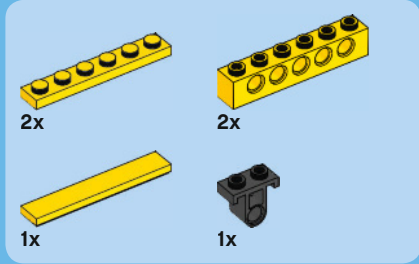



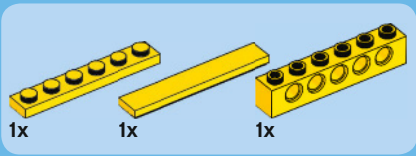

24

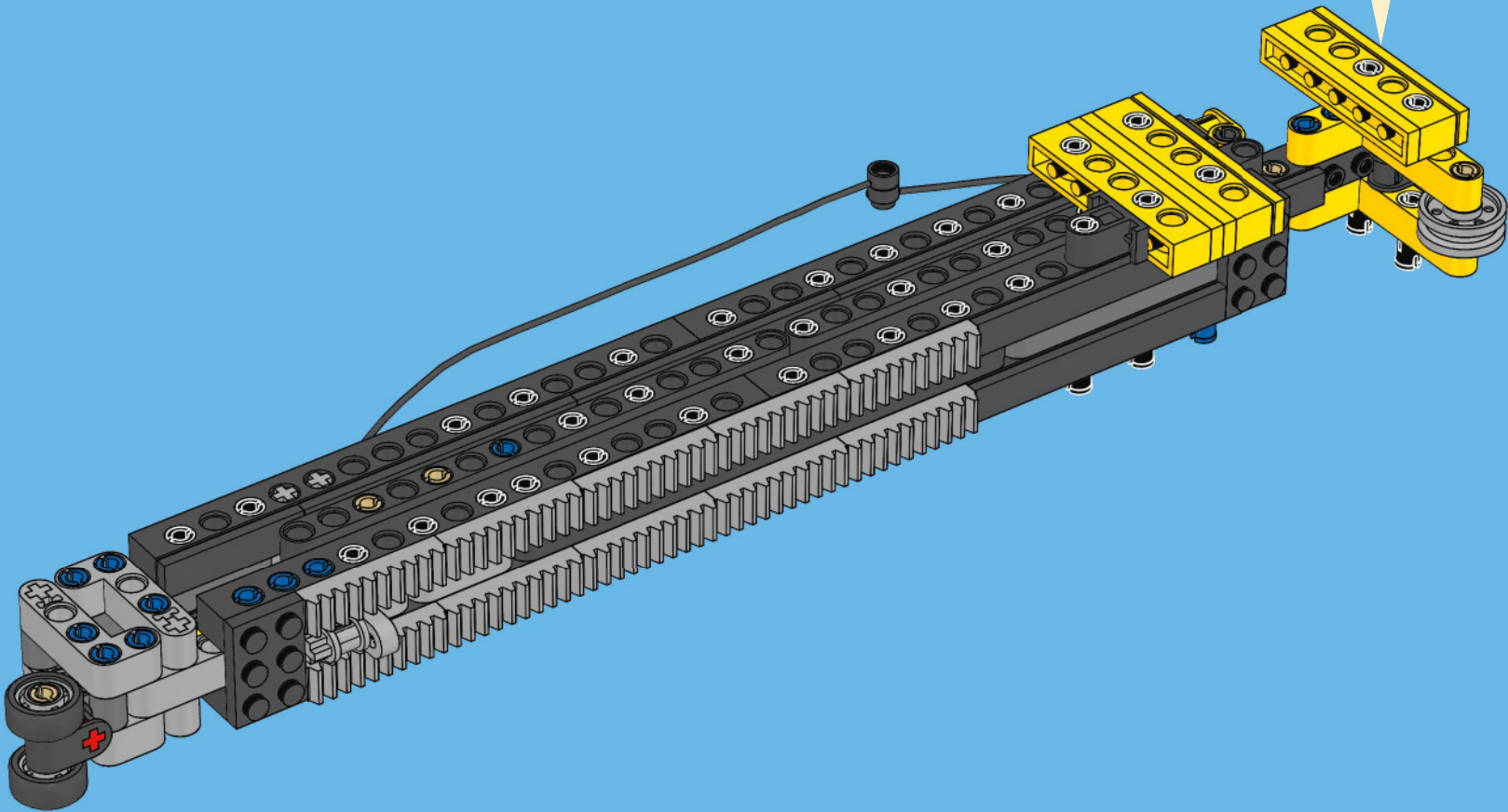
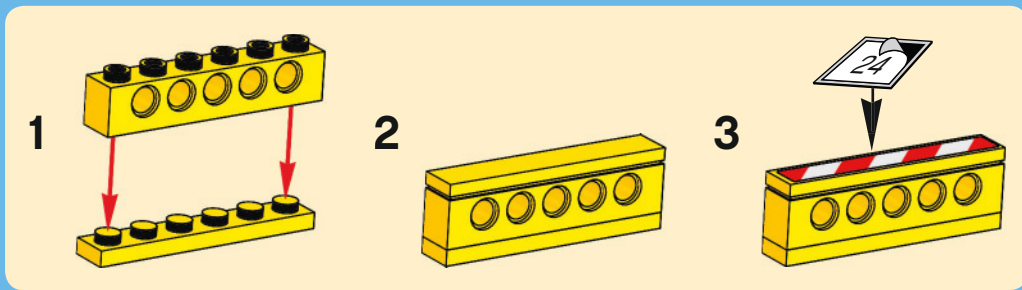

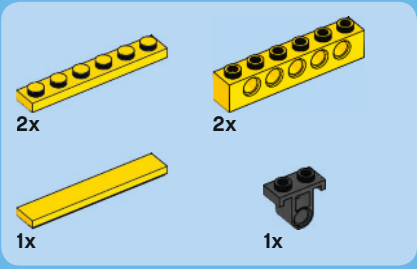

25

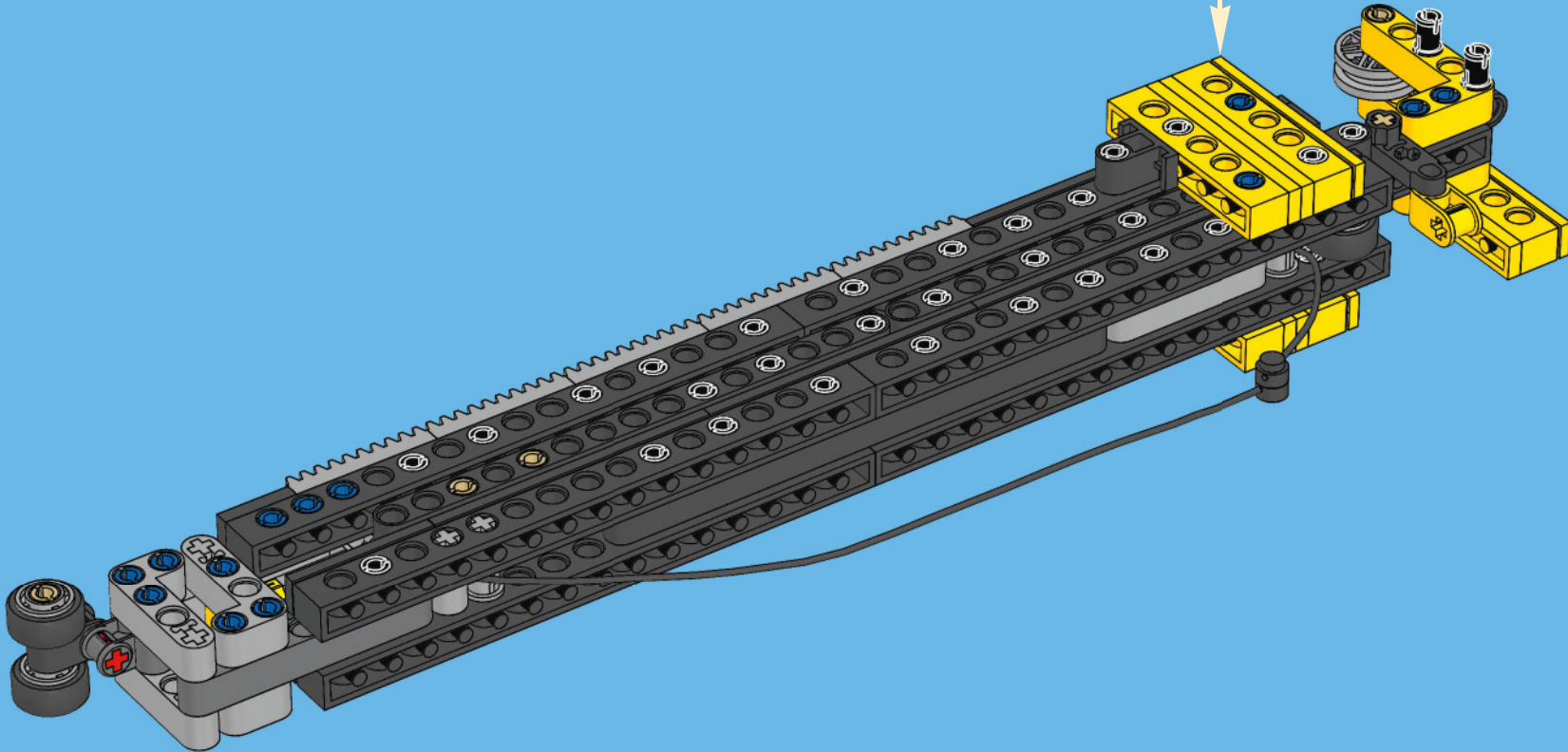
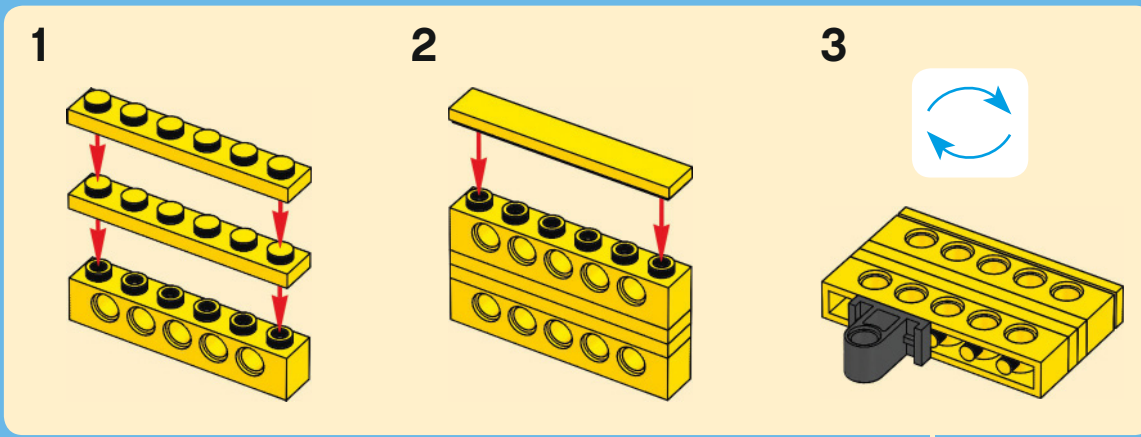

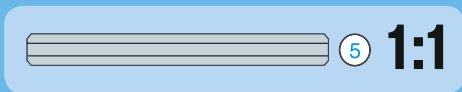
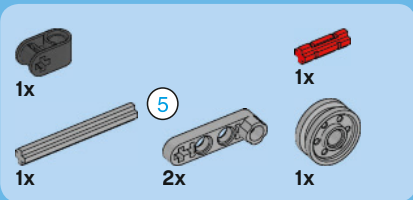

26

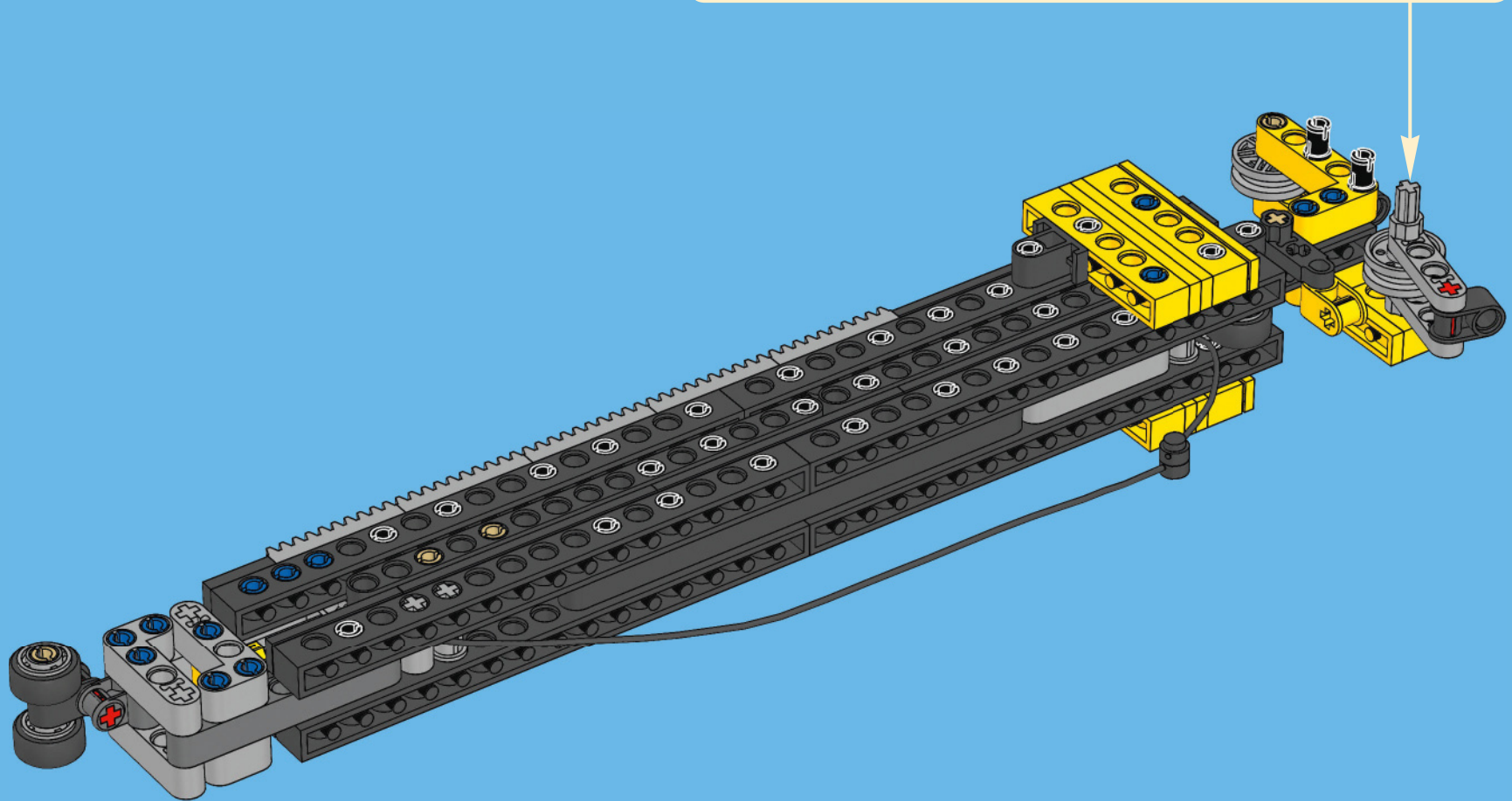
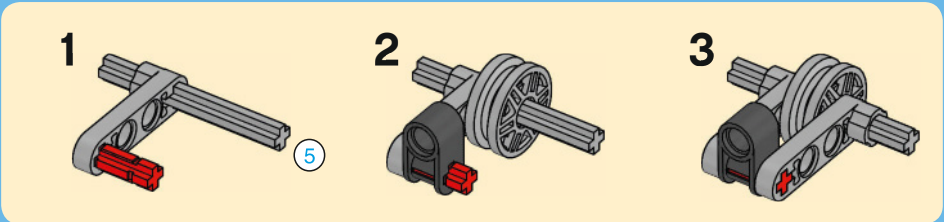



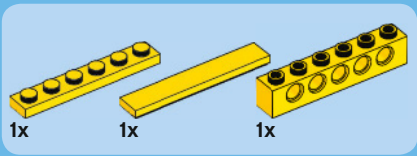

27

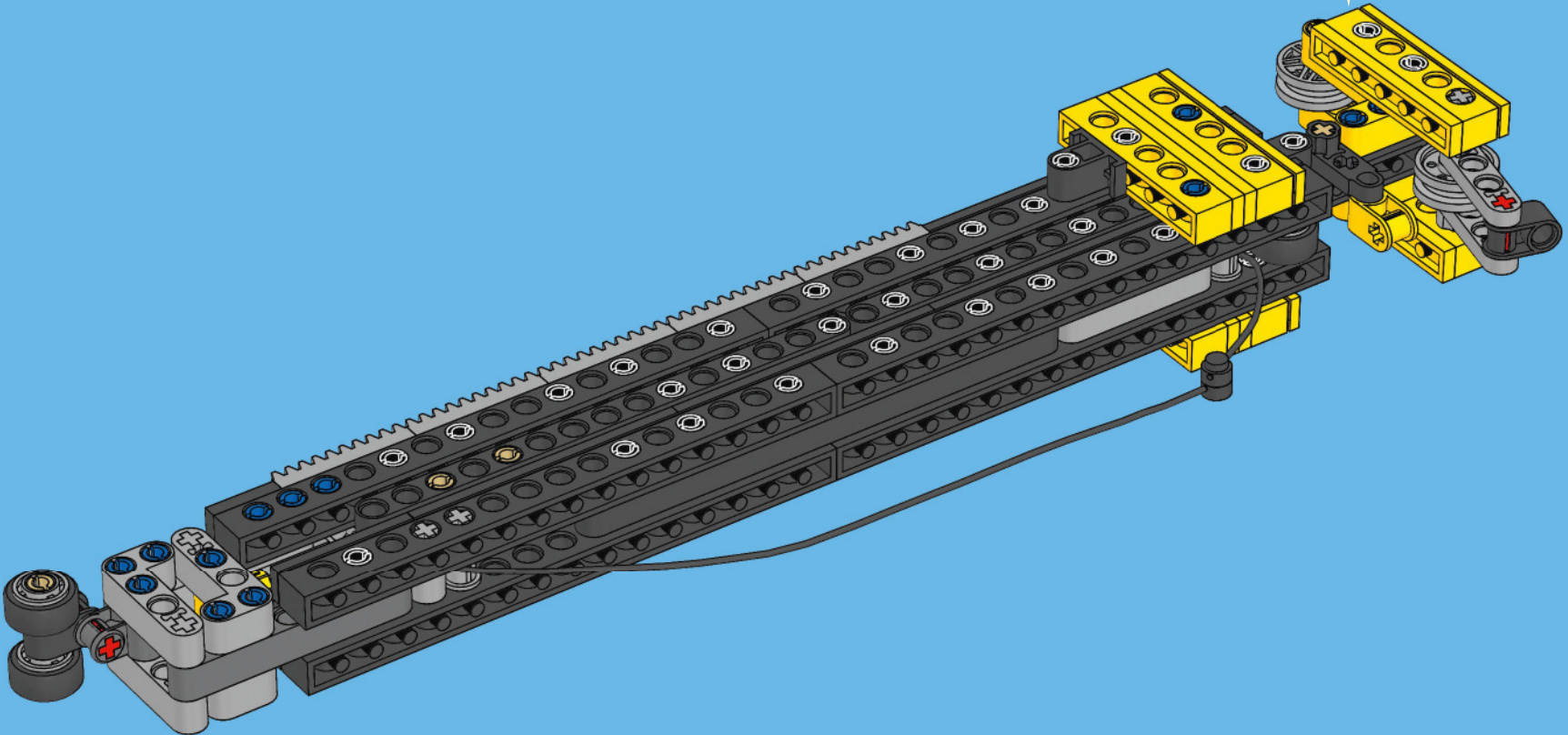
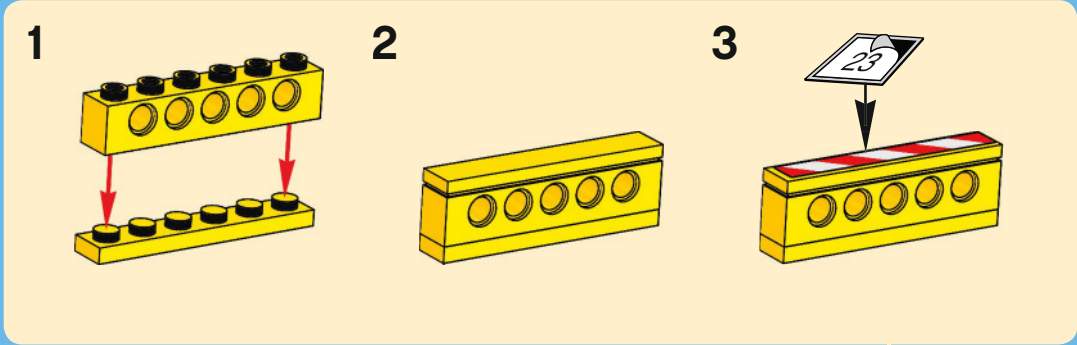

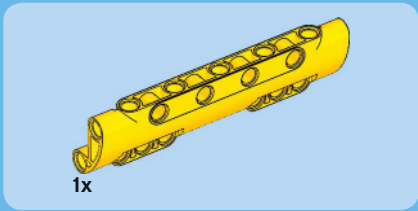
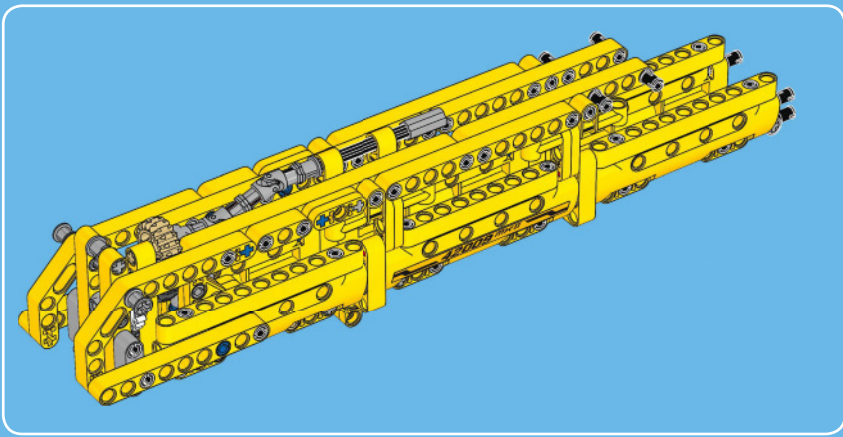

1

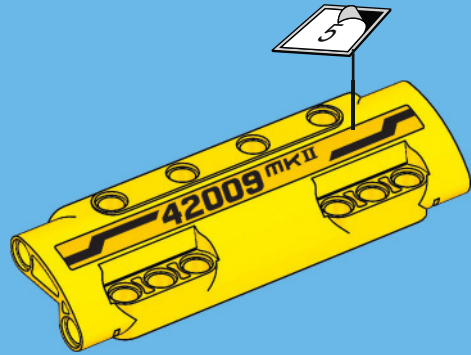

2

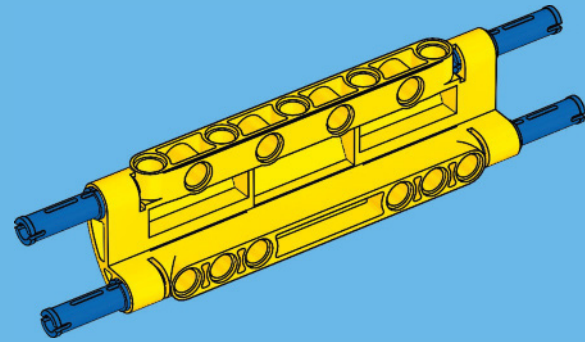

3

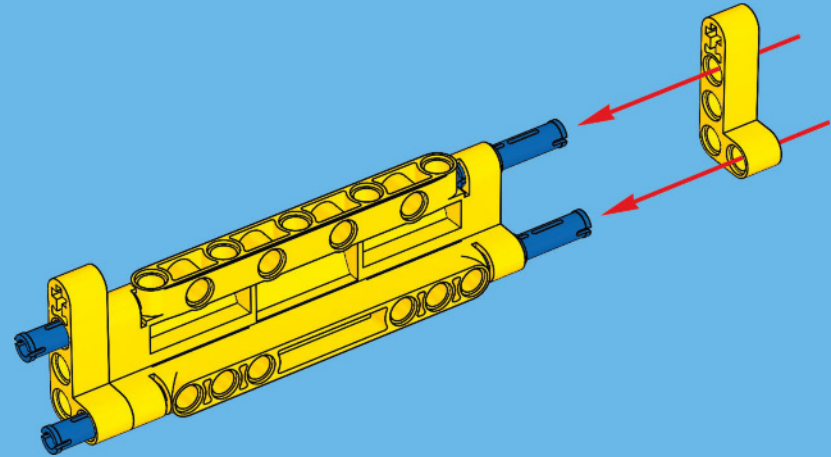

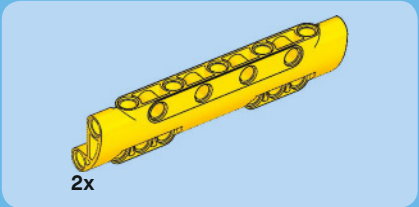

4

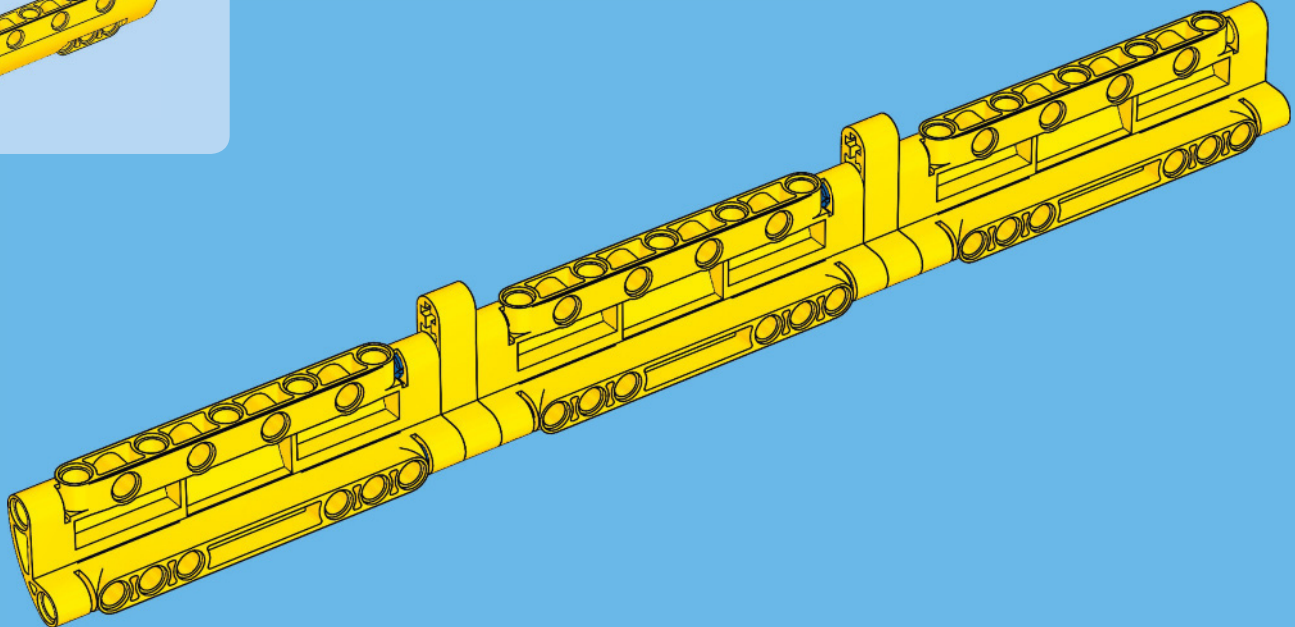

5

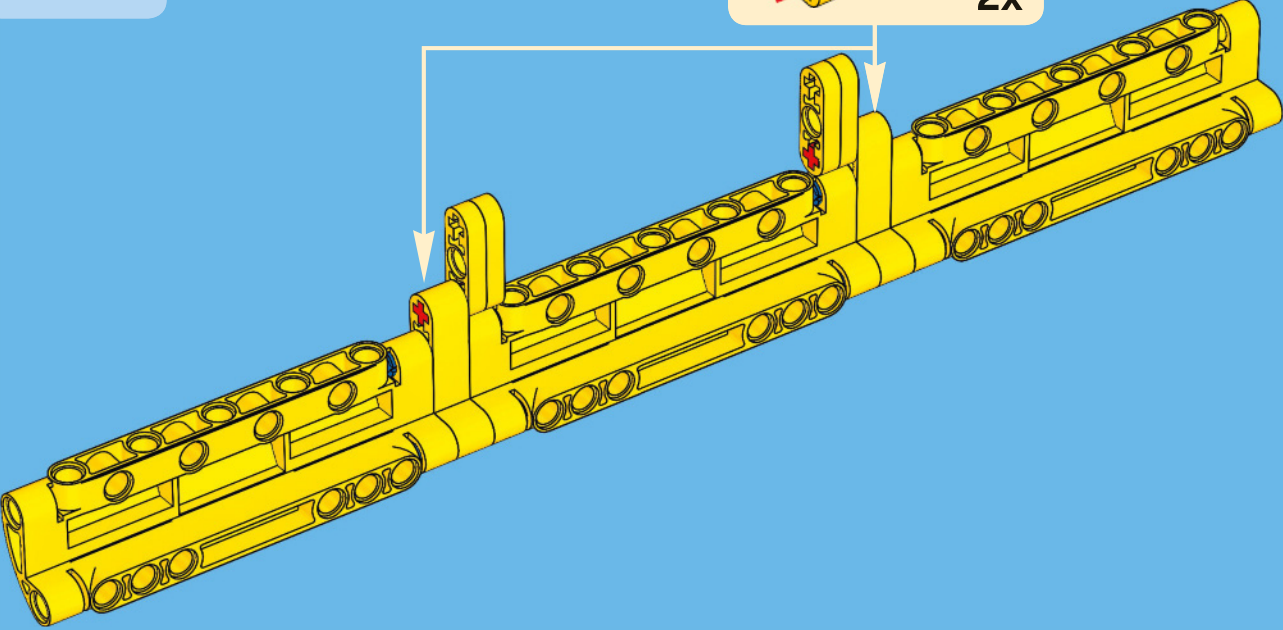
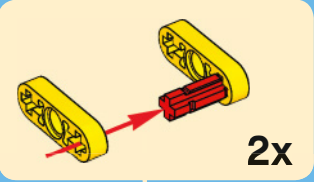



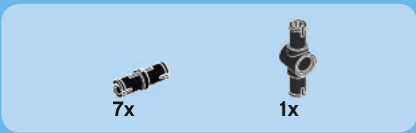

6

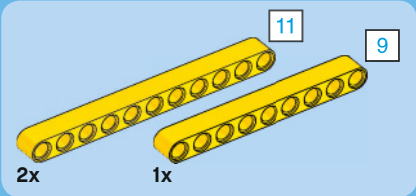
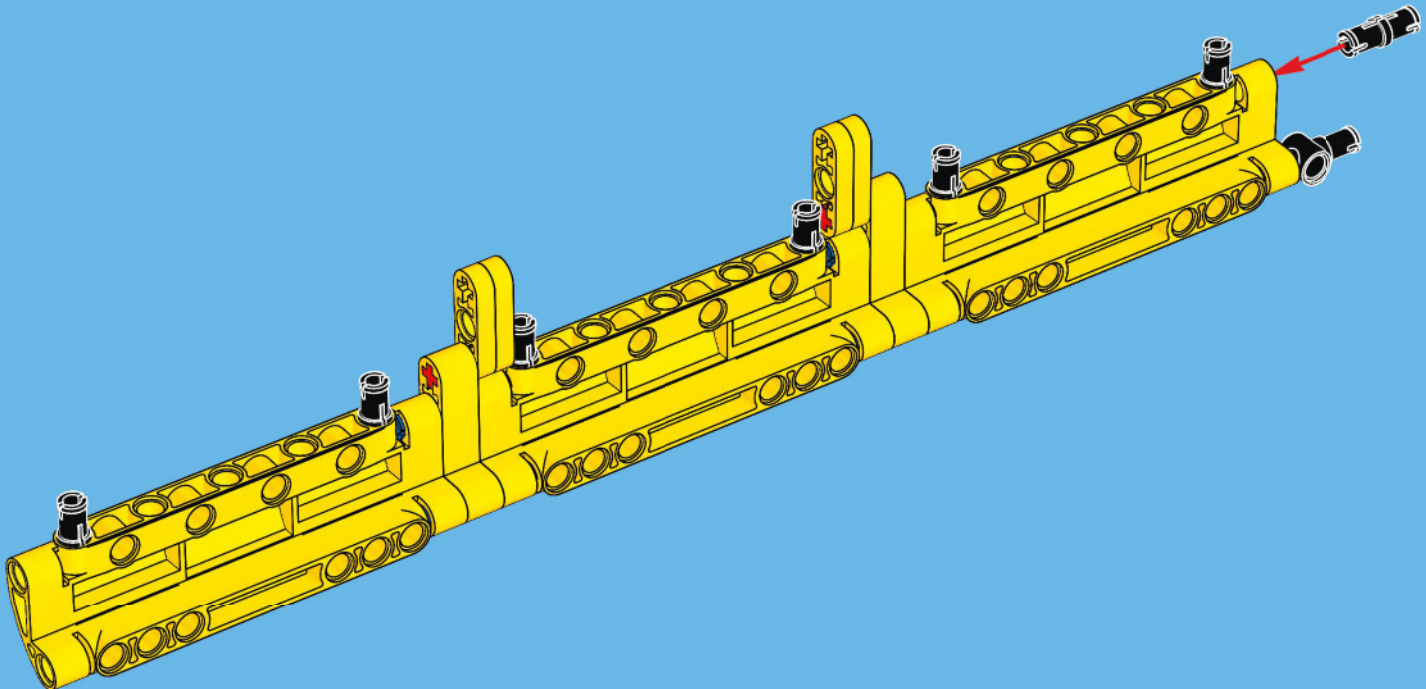

7

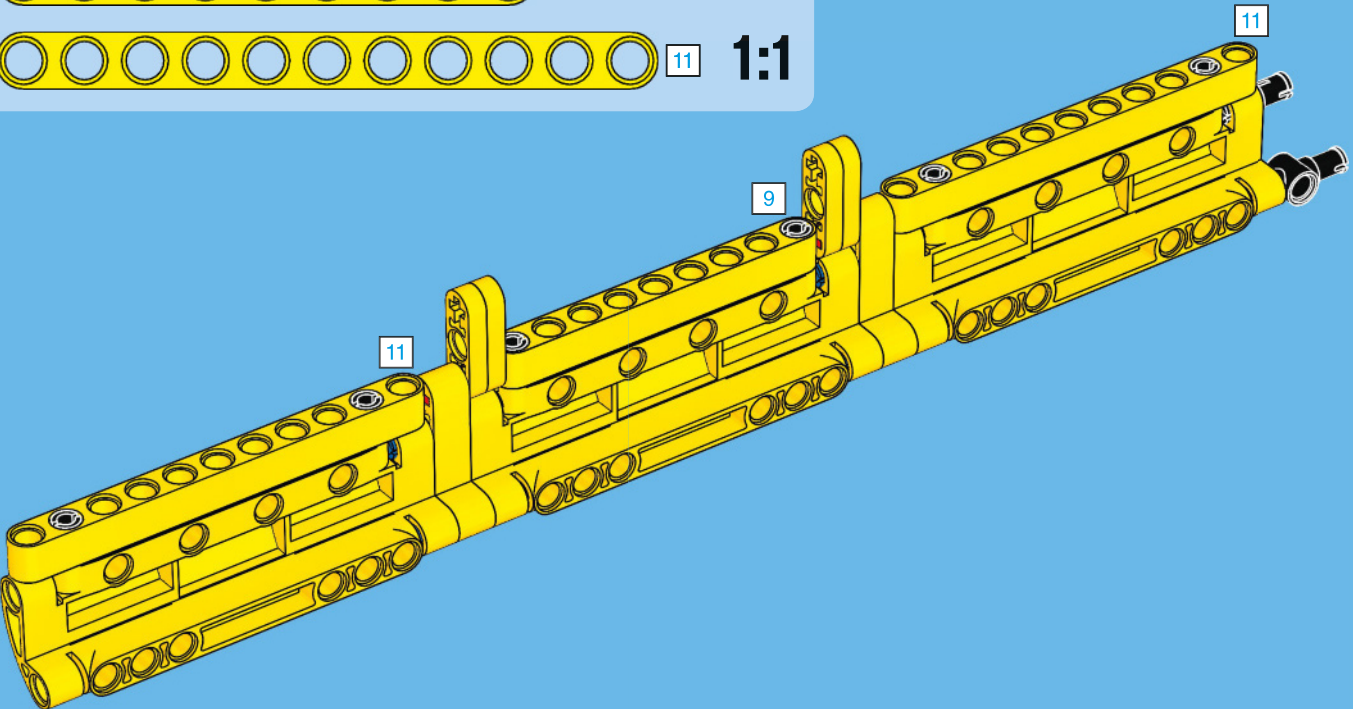
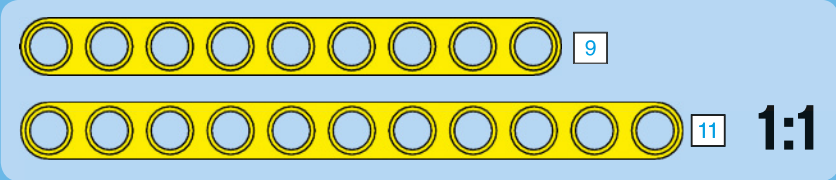

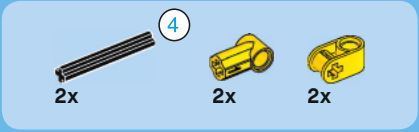

8

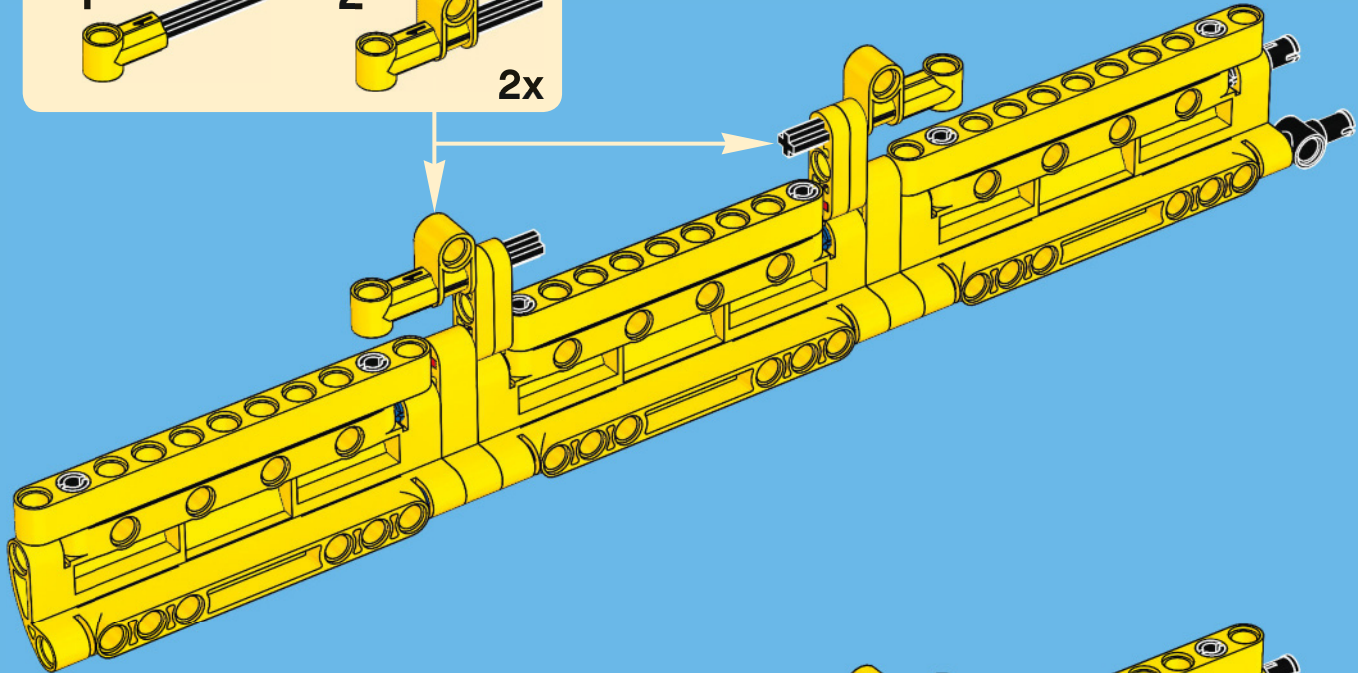
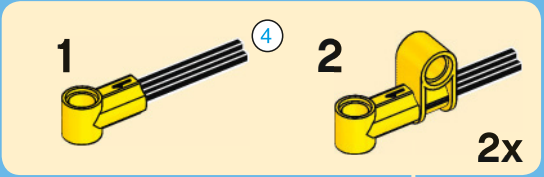

9

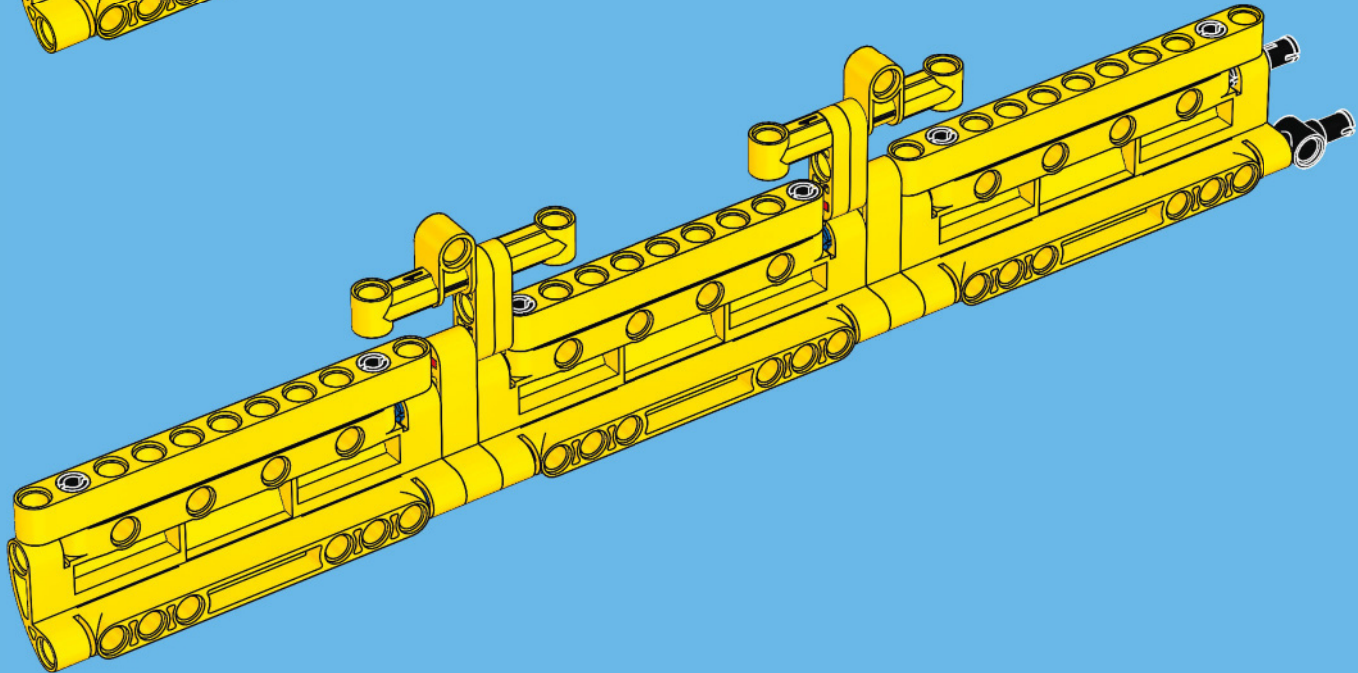

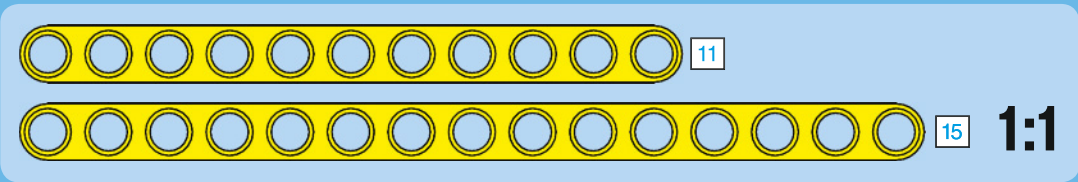
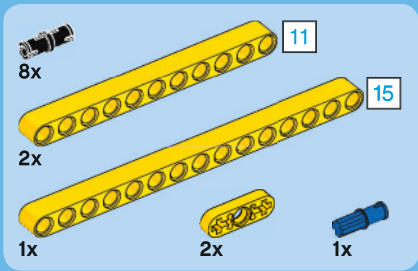

10

1

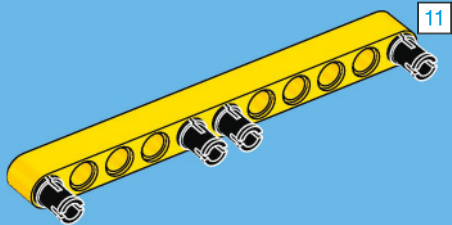

2

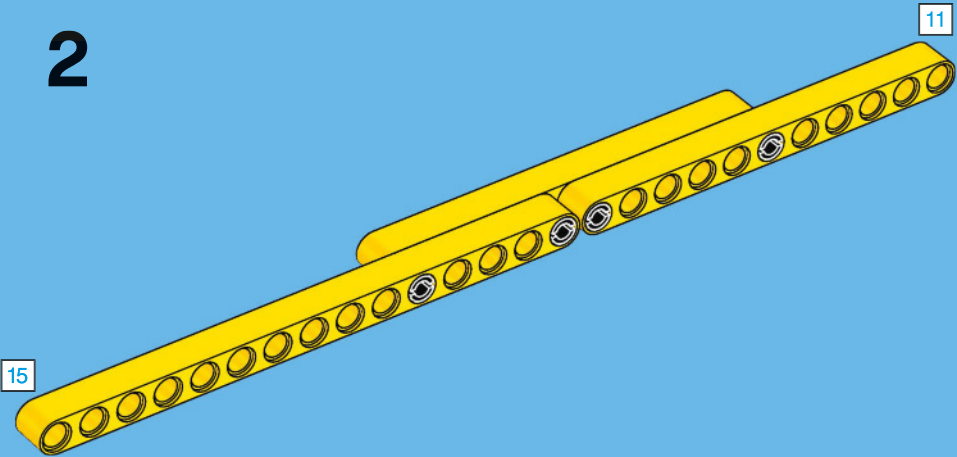

3

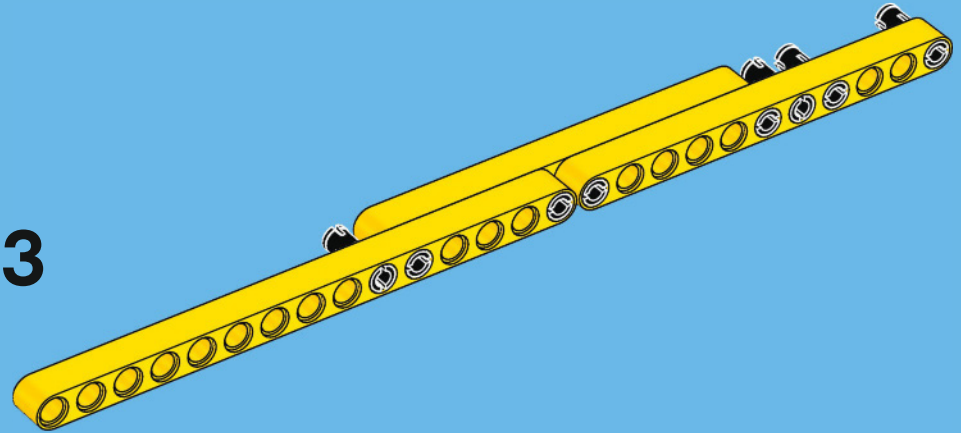

4

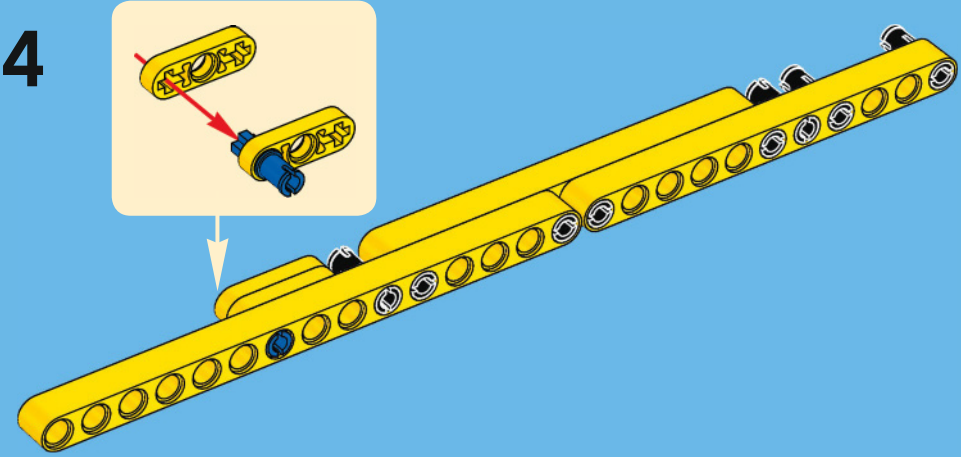



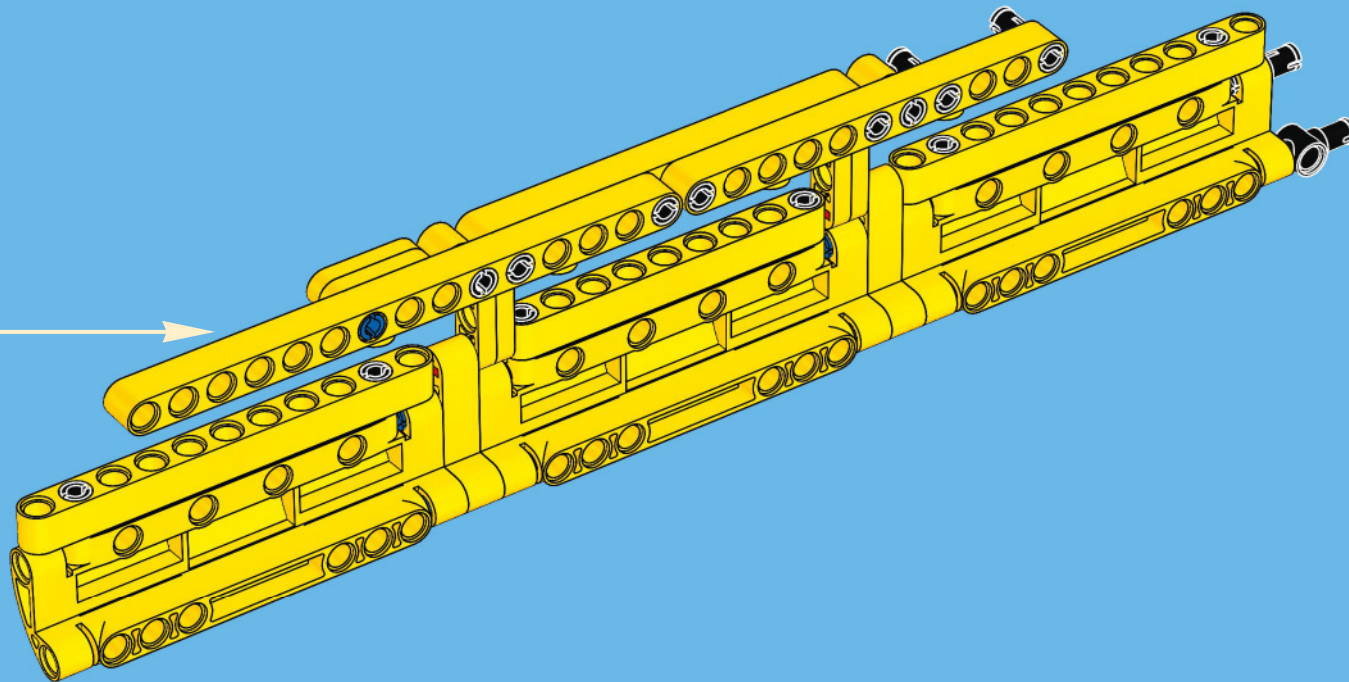

2x



6x

11

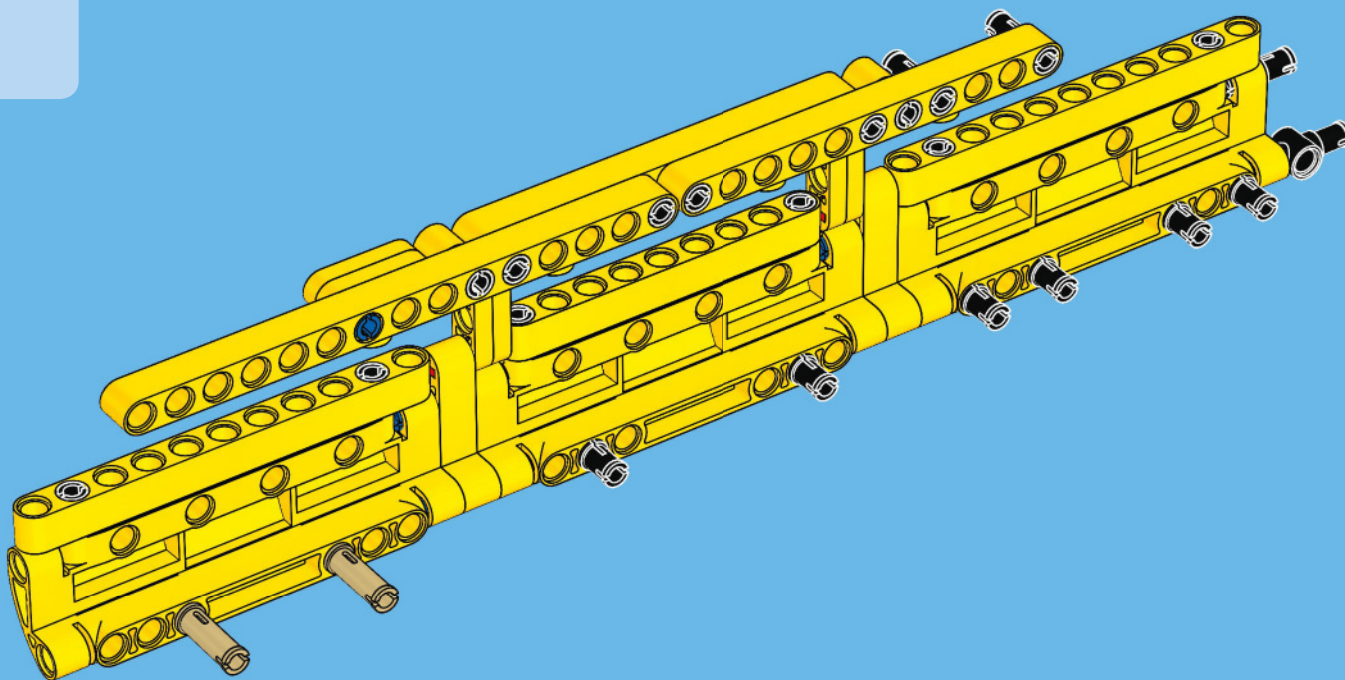

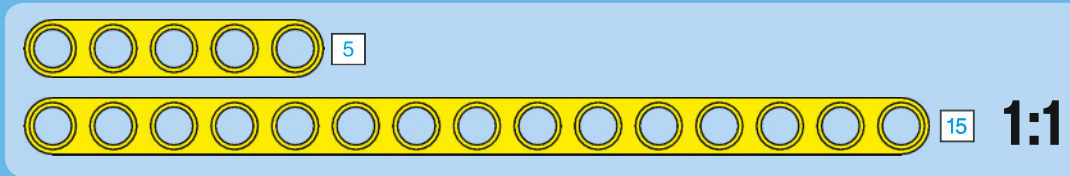
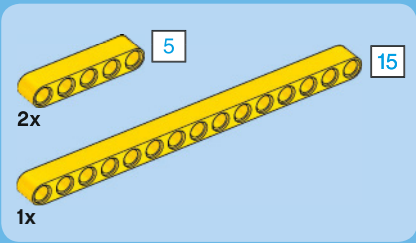

12

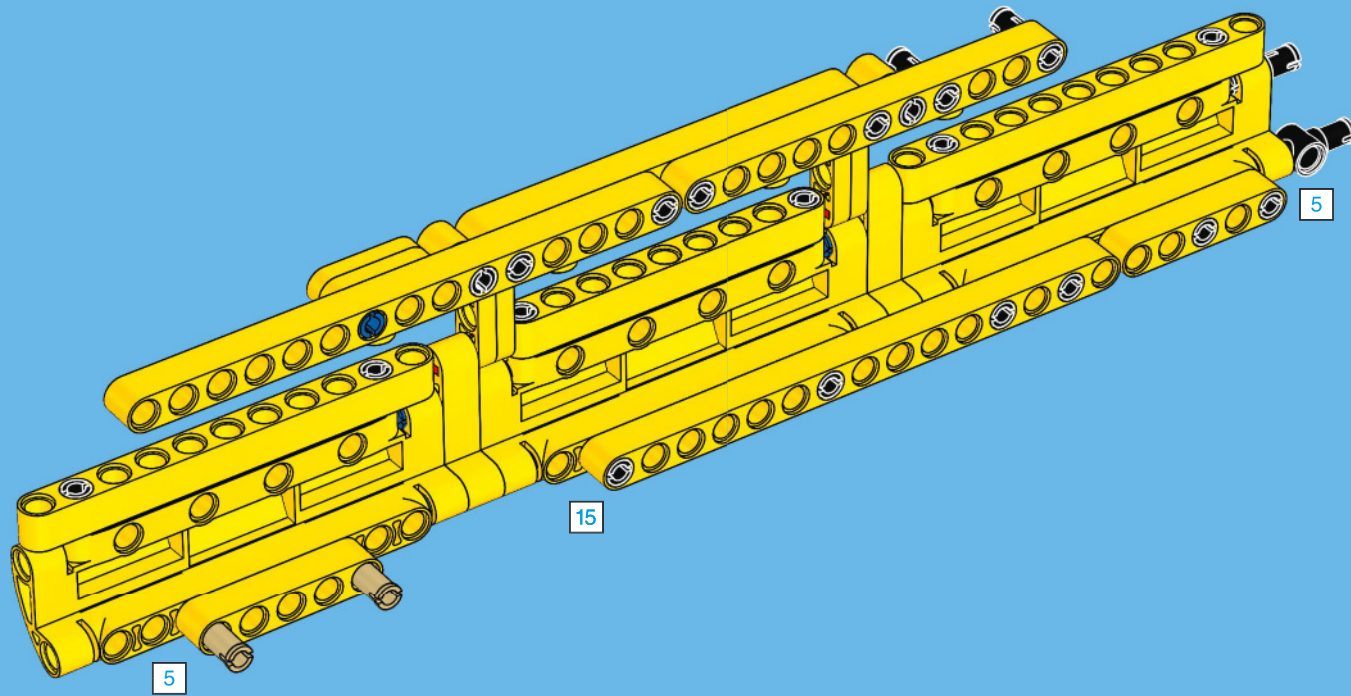



4x

# 13

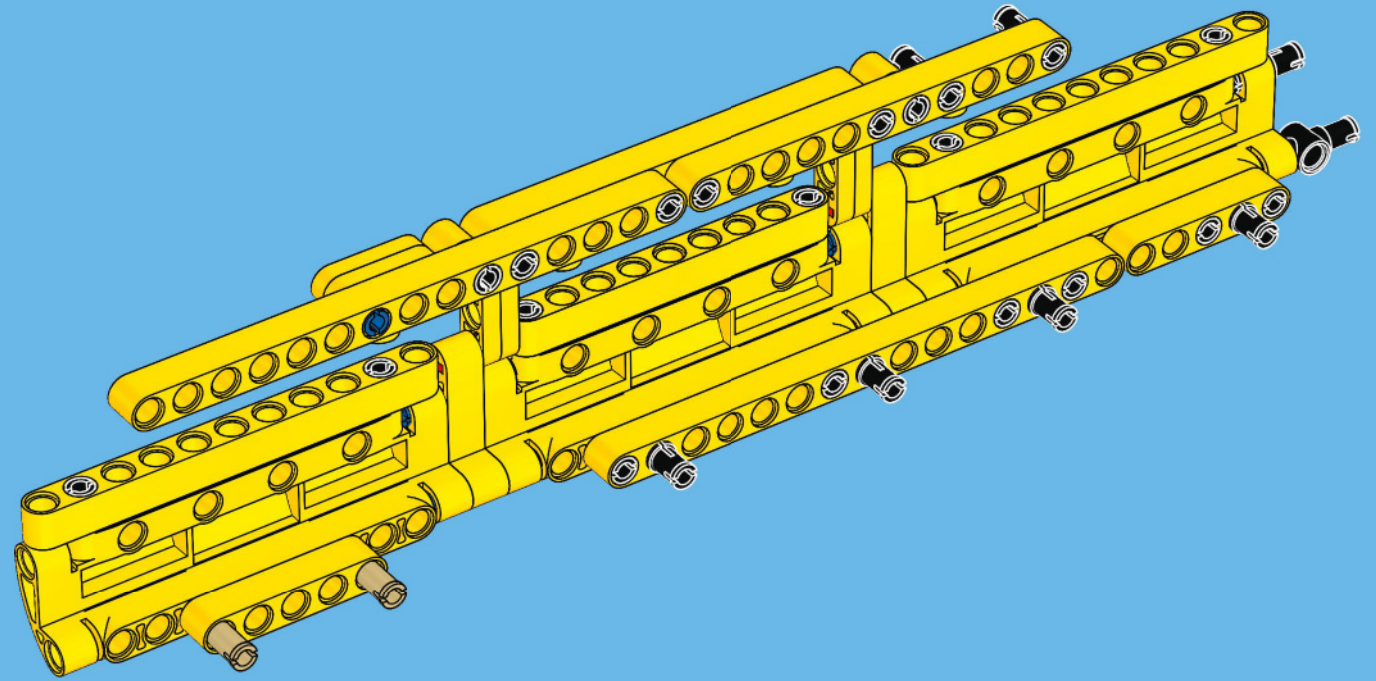

1x

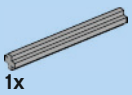

1x

5



2x

# 14

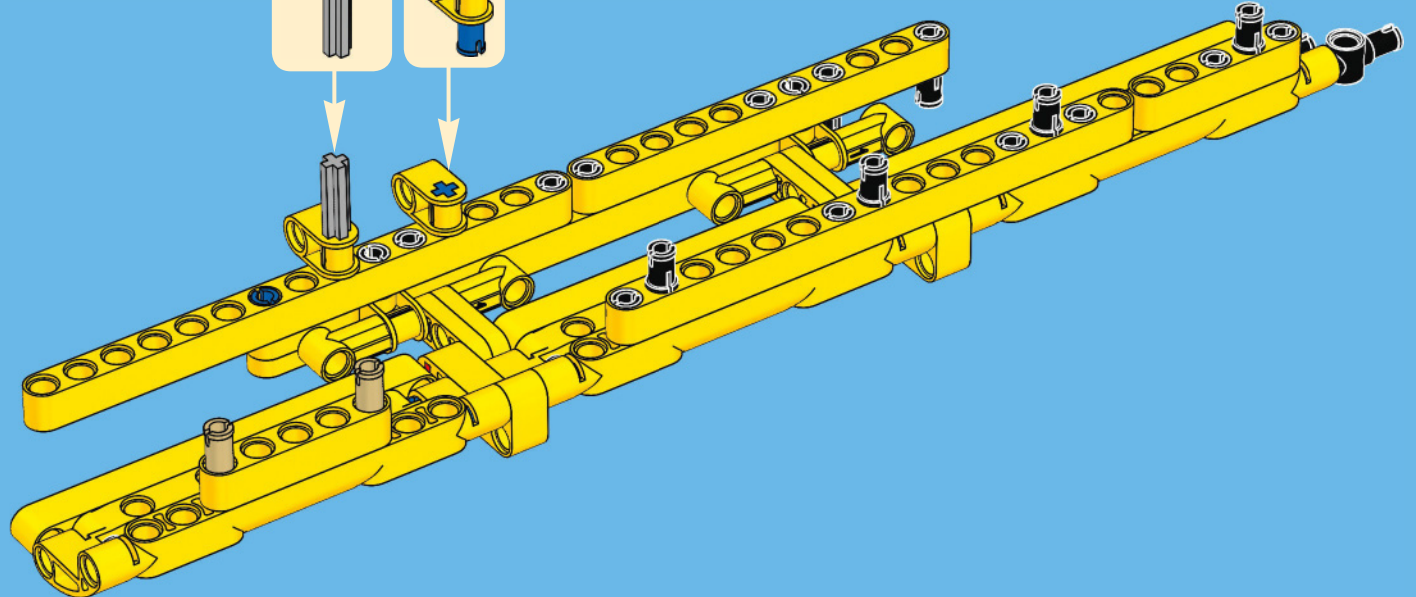
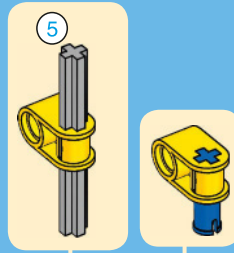

5

1:1



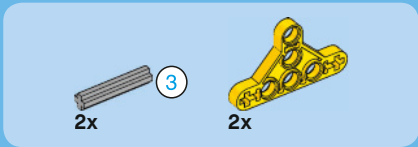
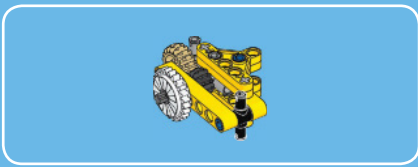

1

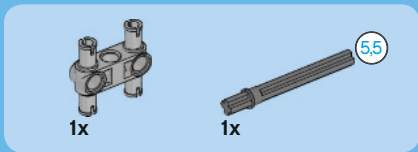
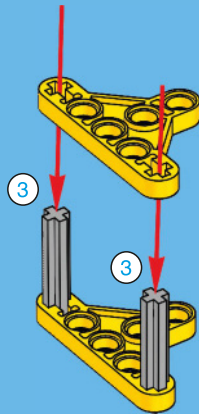
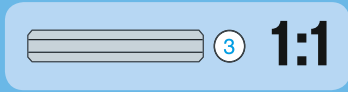

2

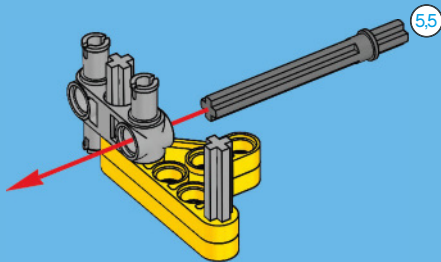

3

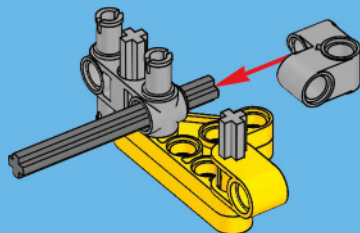

4

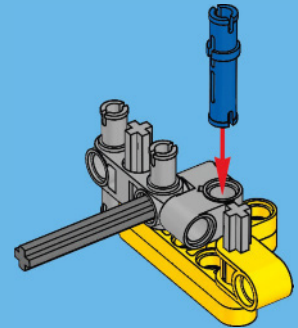

5

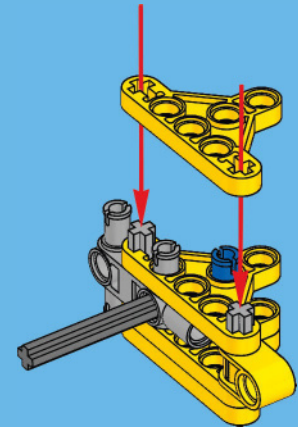

6

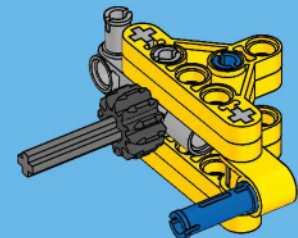

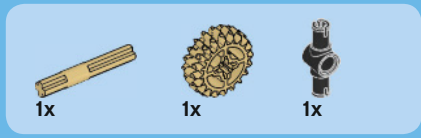

7

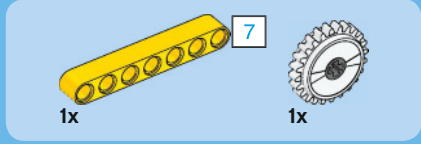
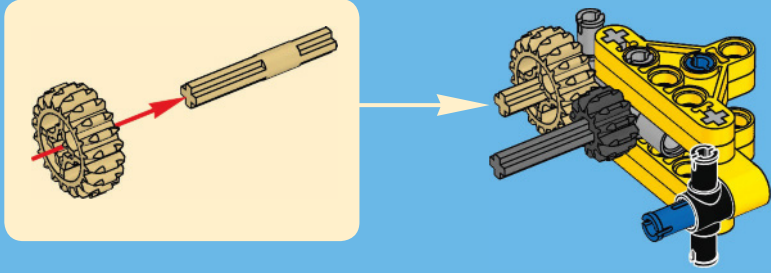

8

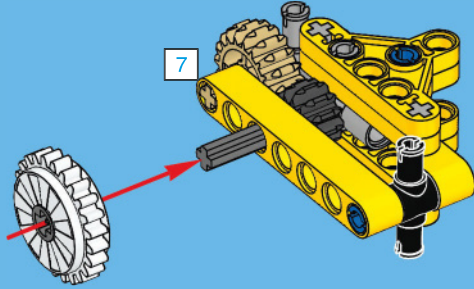
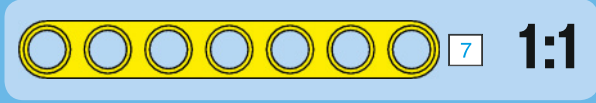

17

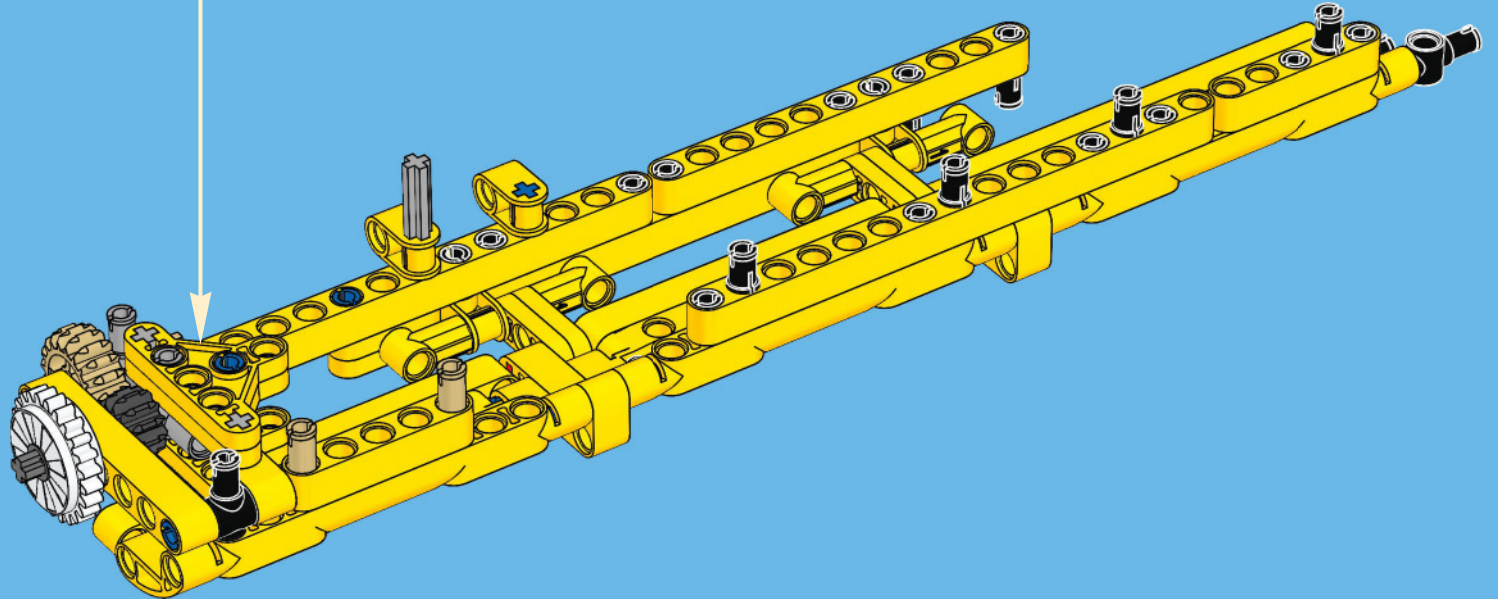

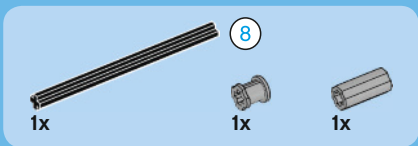

18

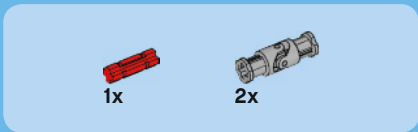
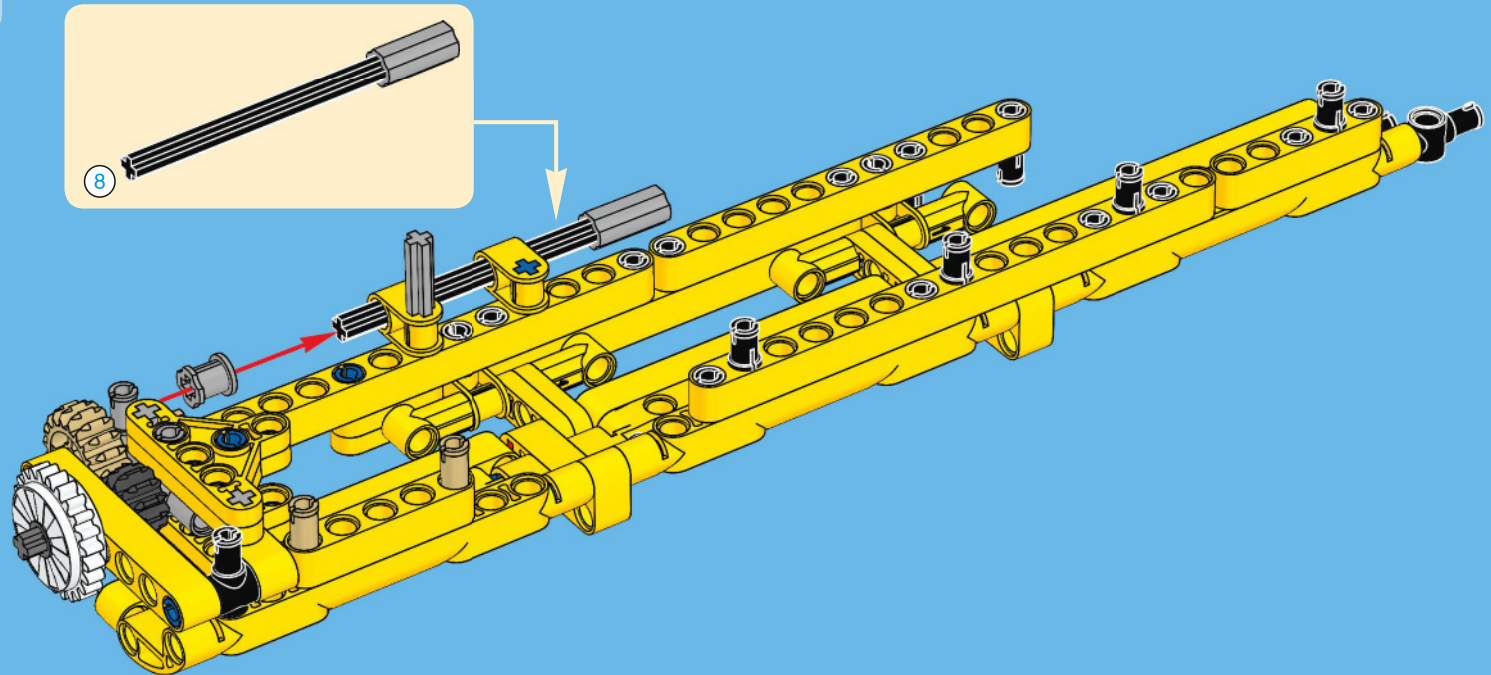

19

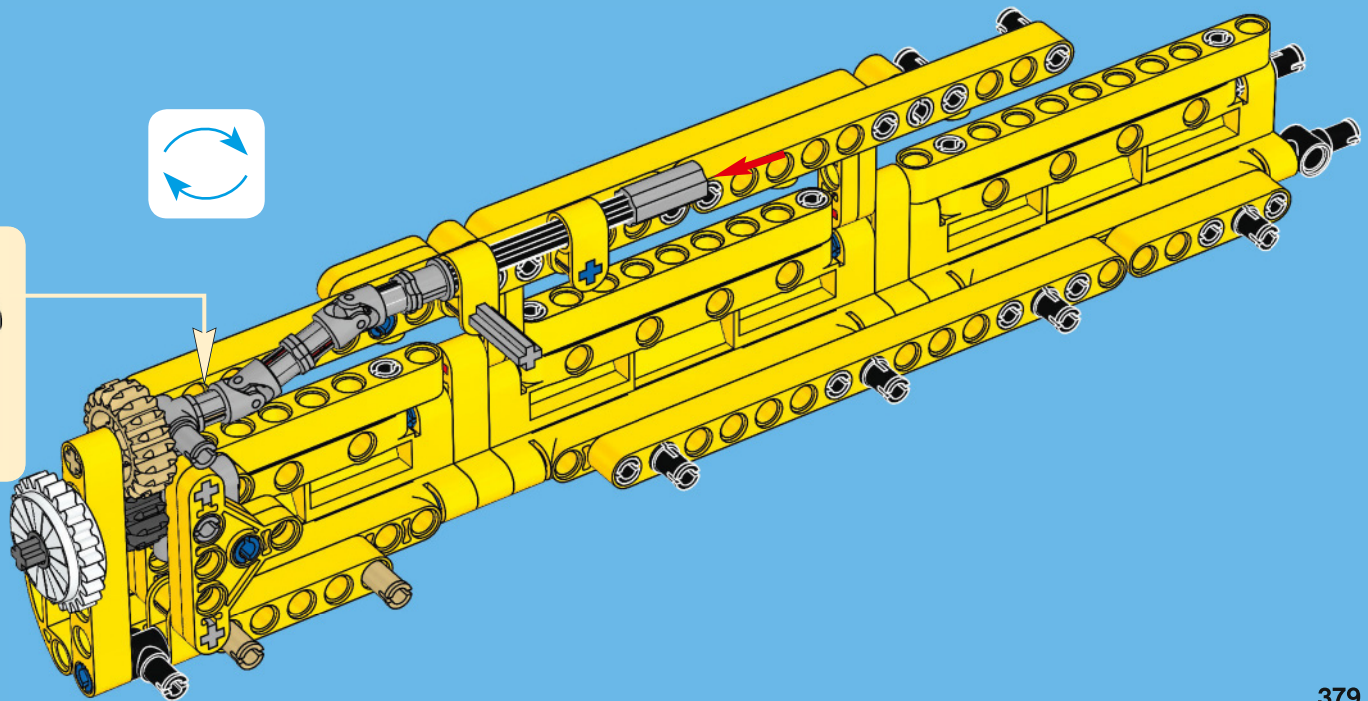
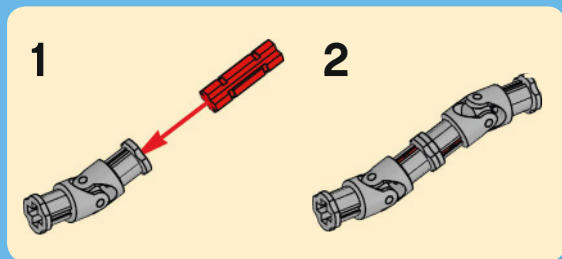



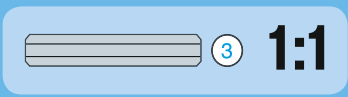
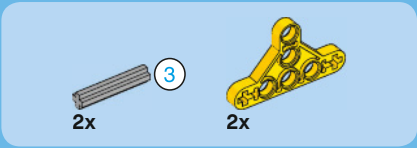

20

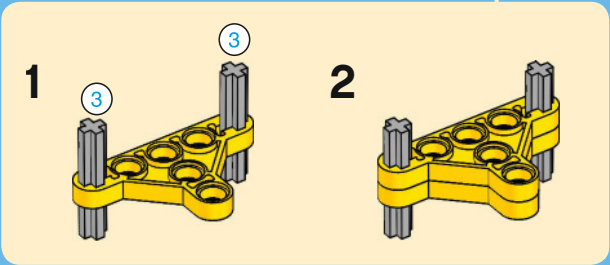
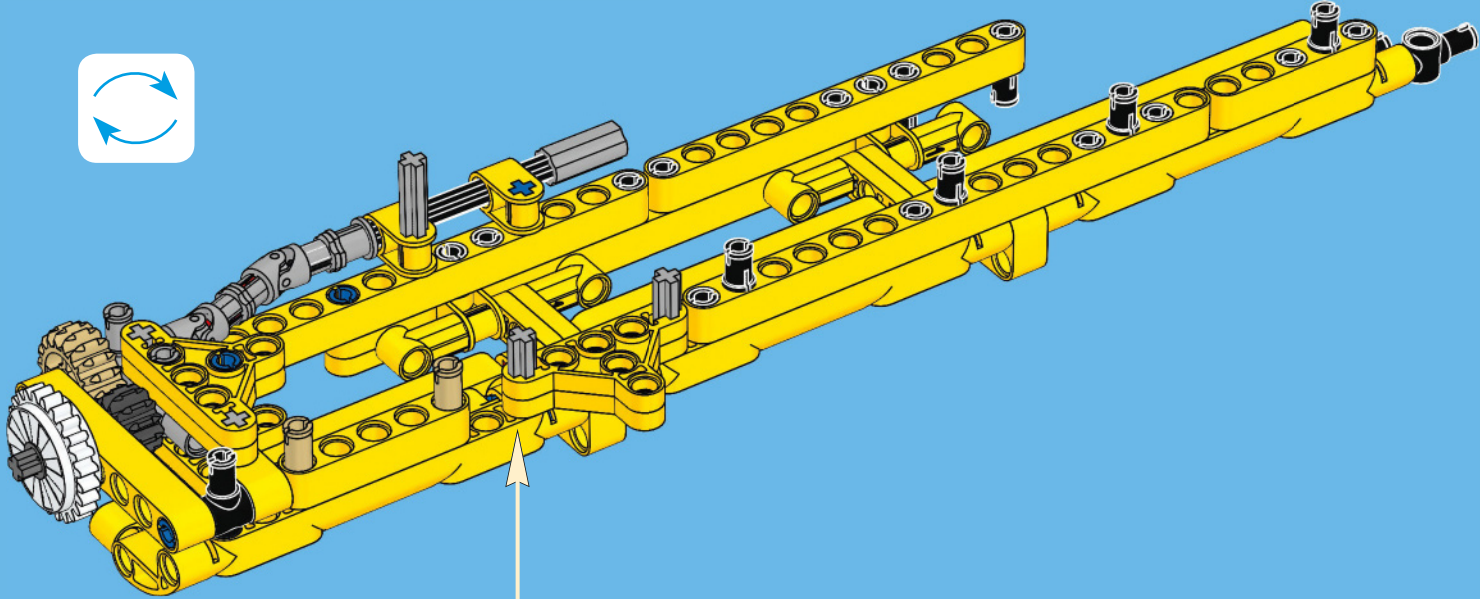

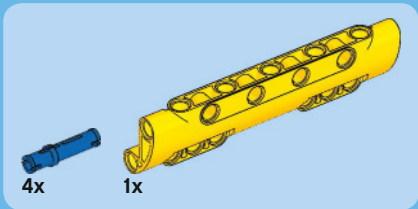
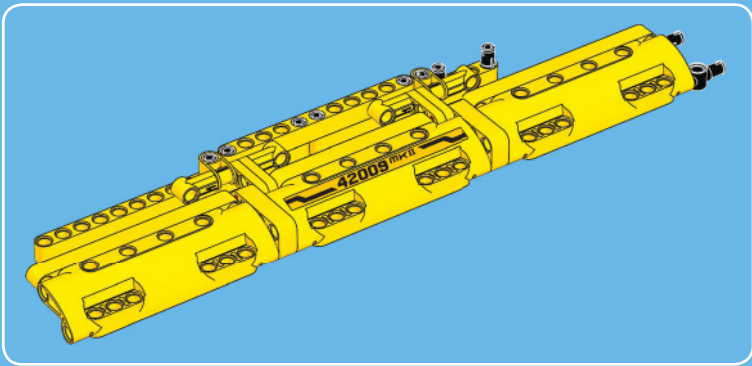

1



2

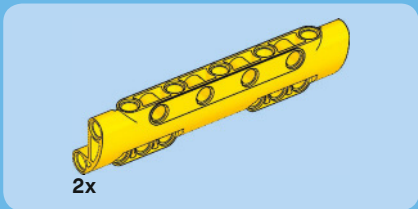

3

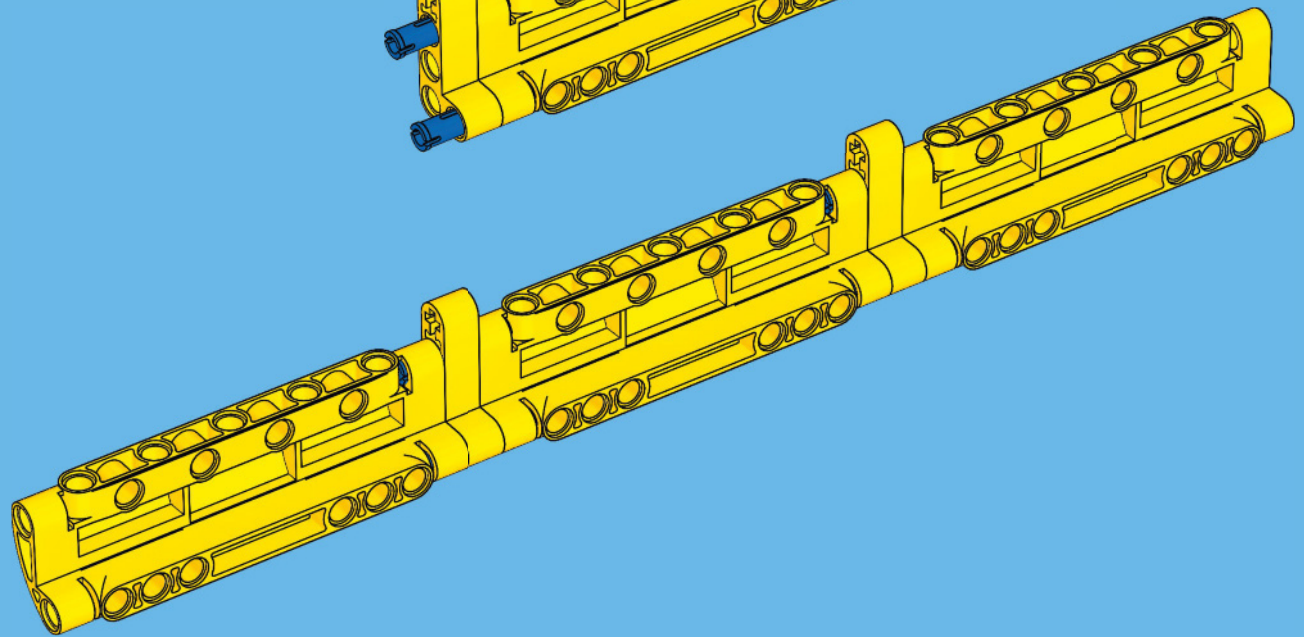
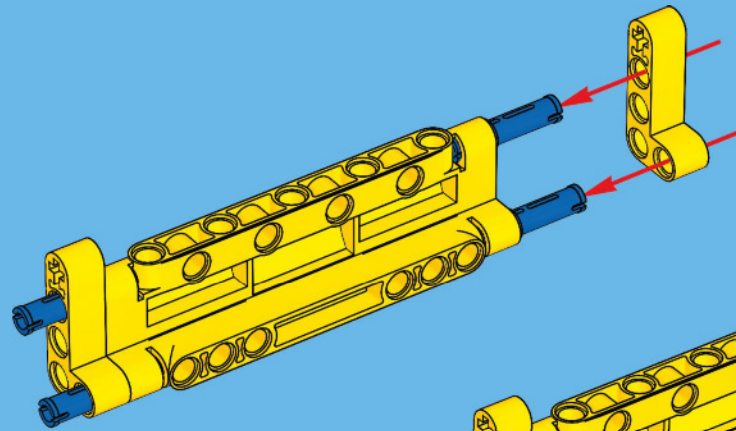
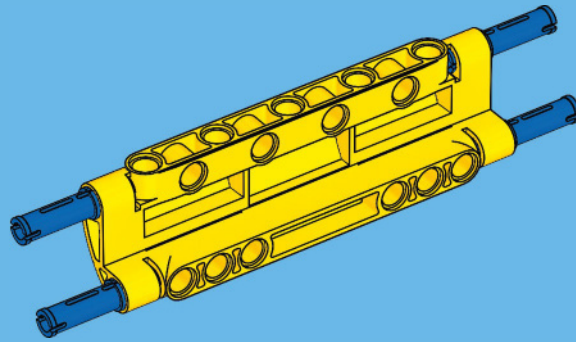



4x



2x

4

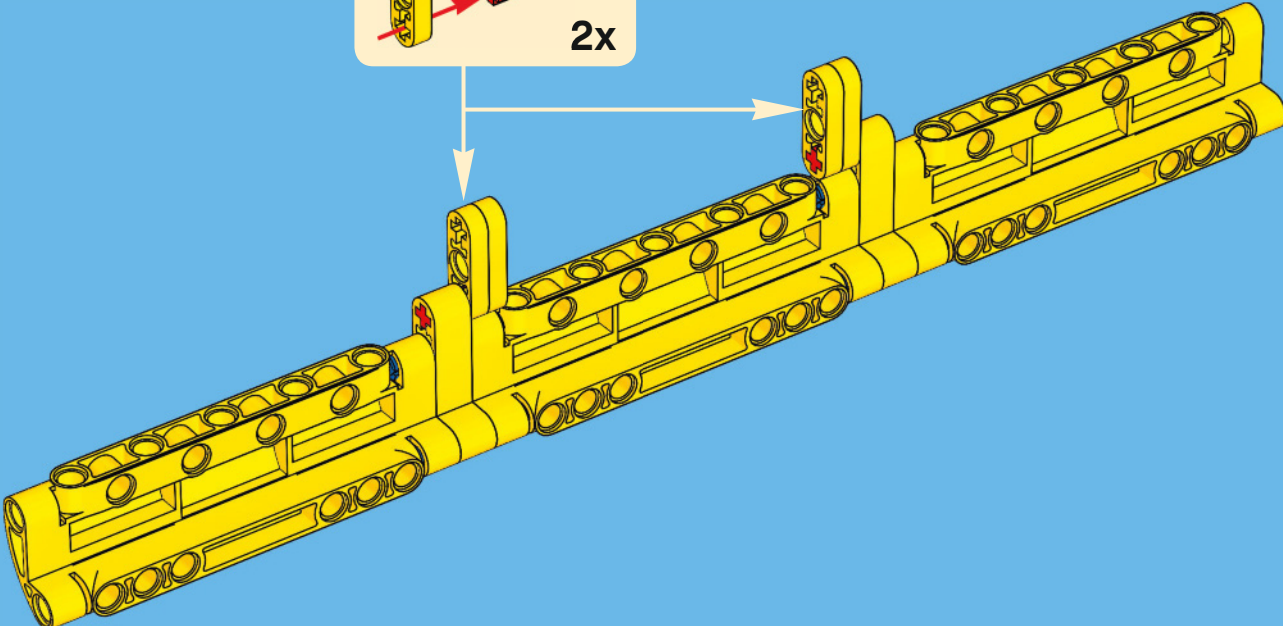
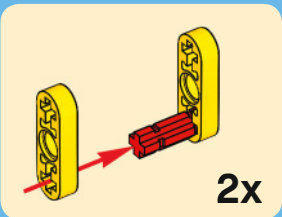

7x



1x

5

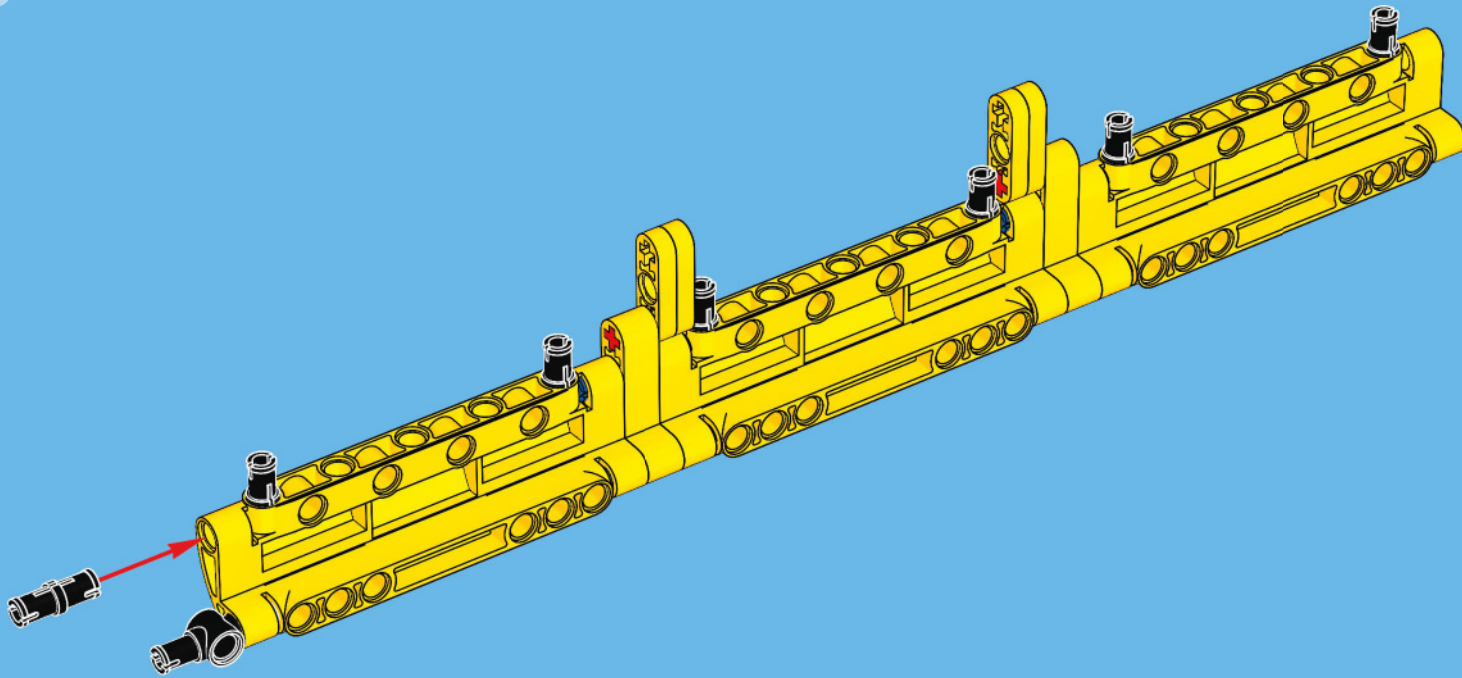



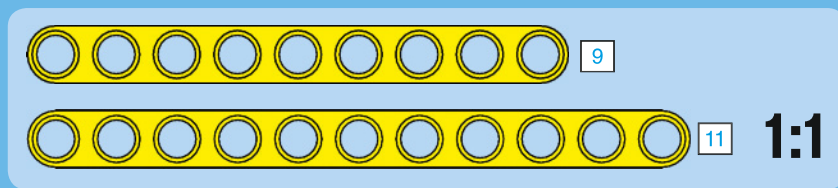
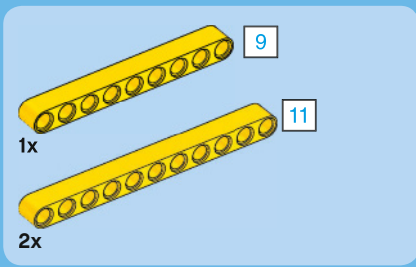

6

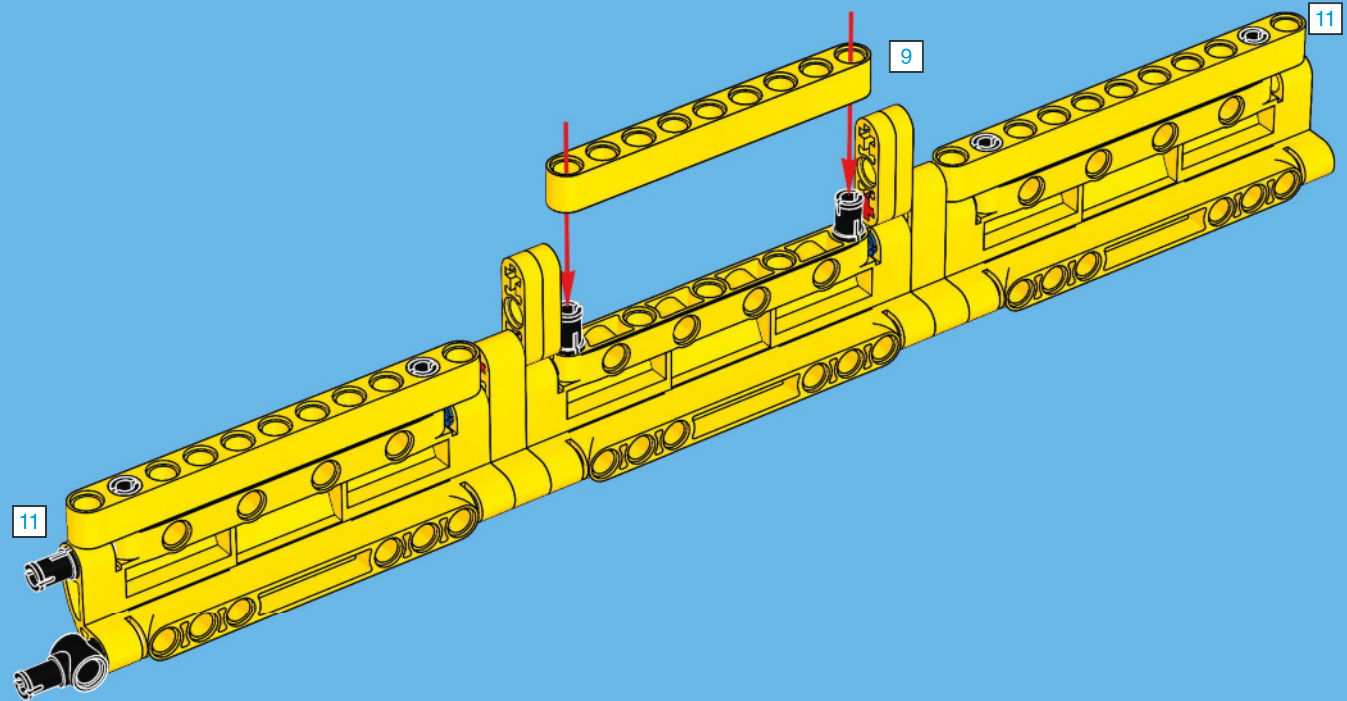

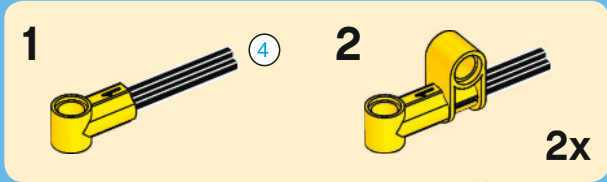
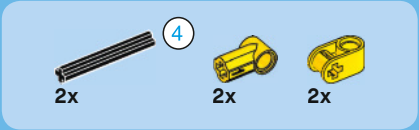

7

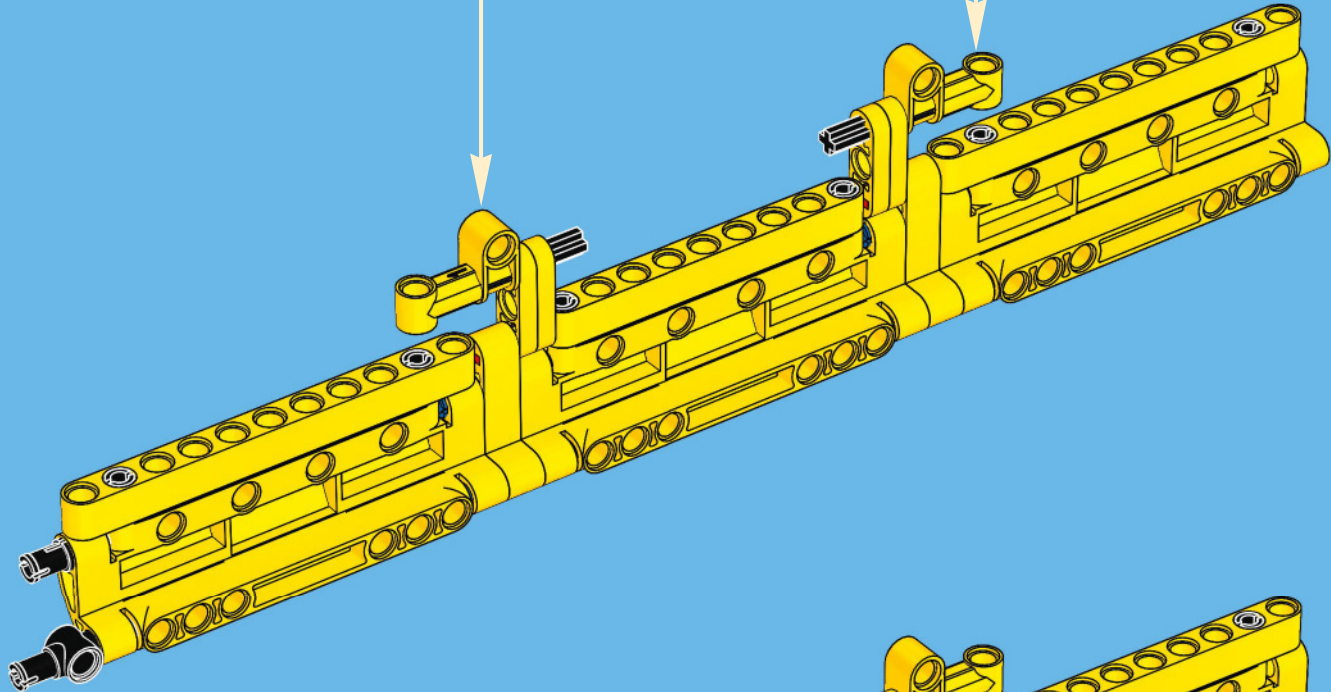

8

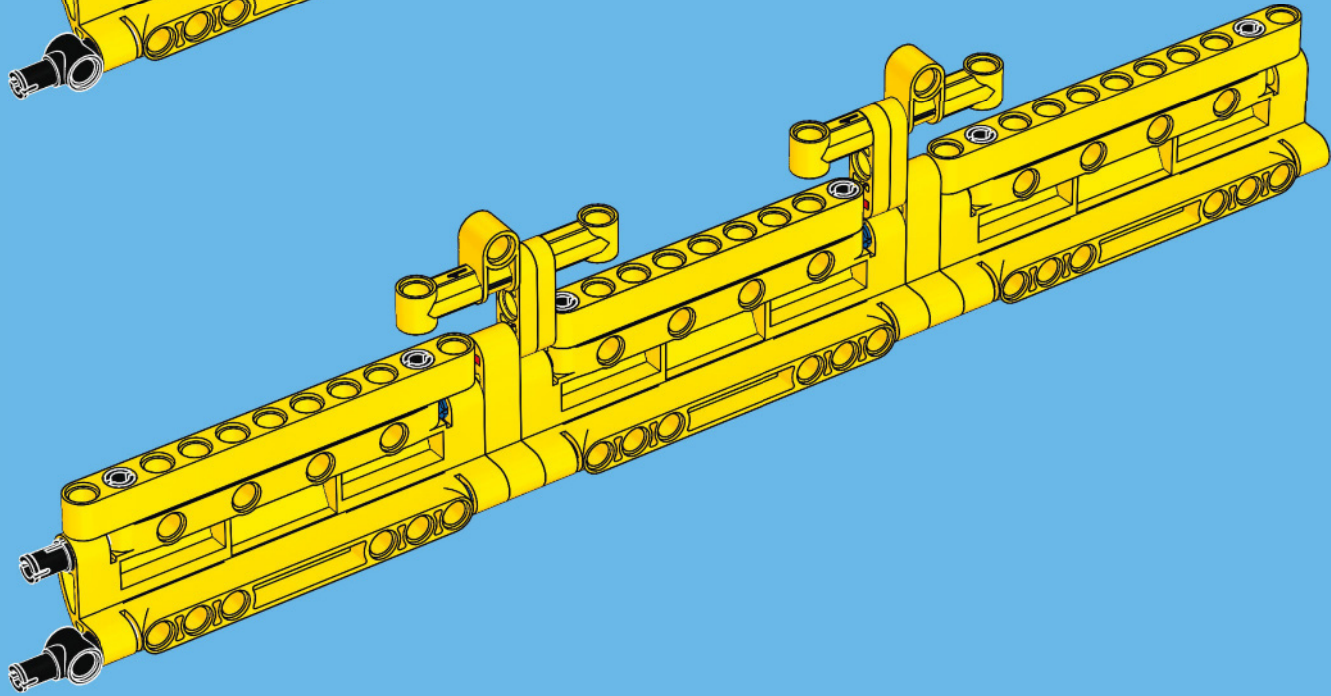

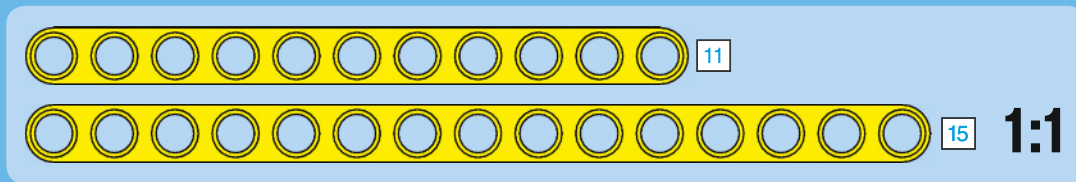
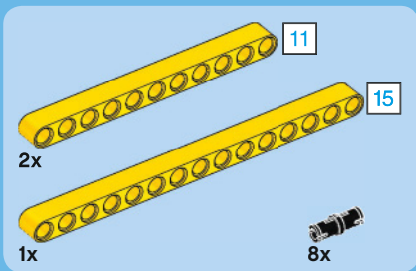

# 9

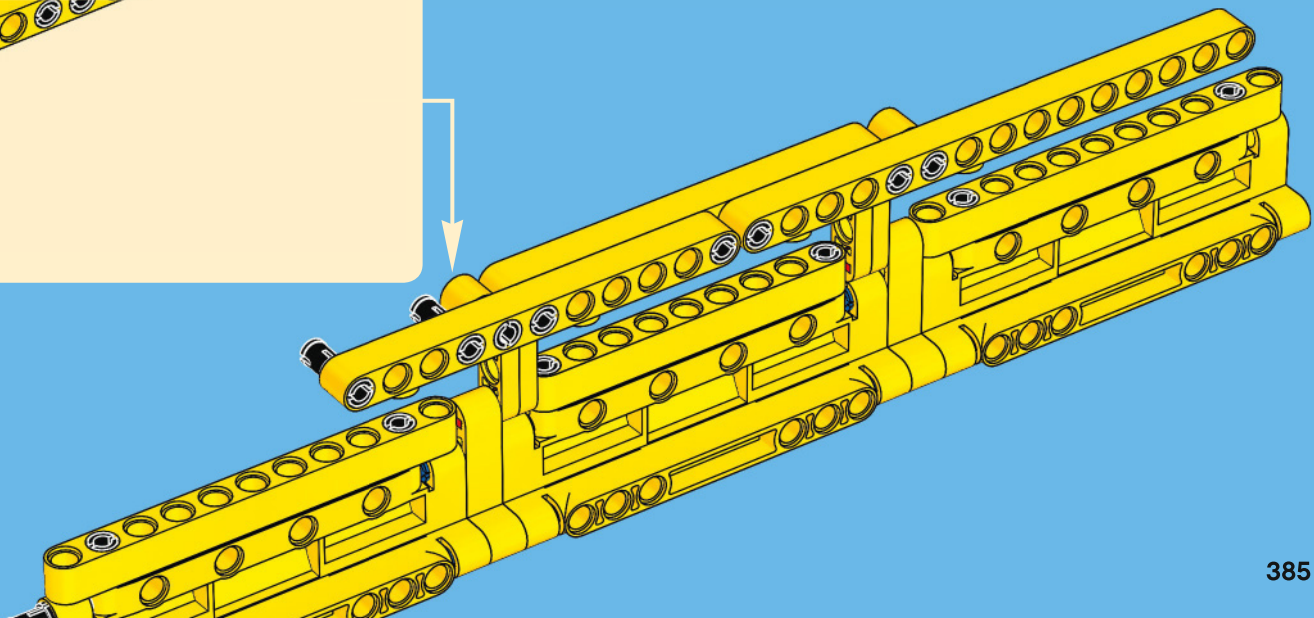
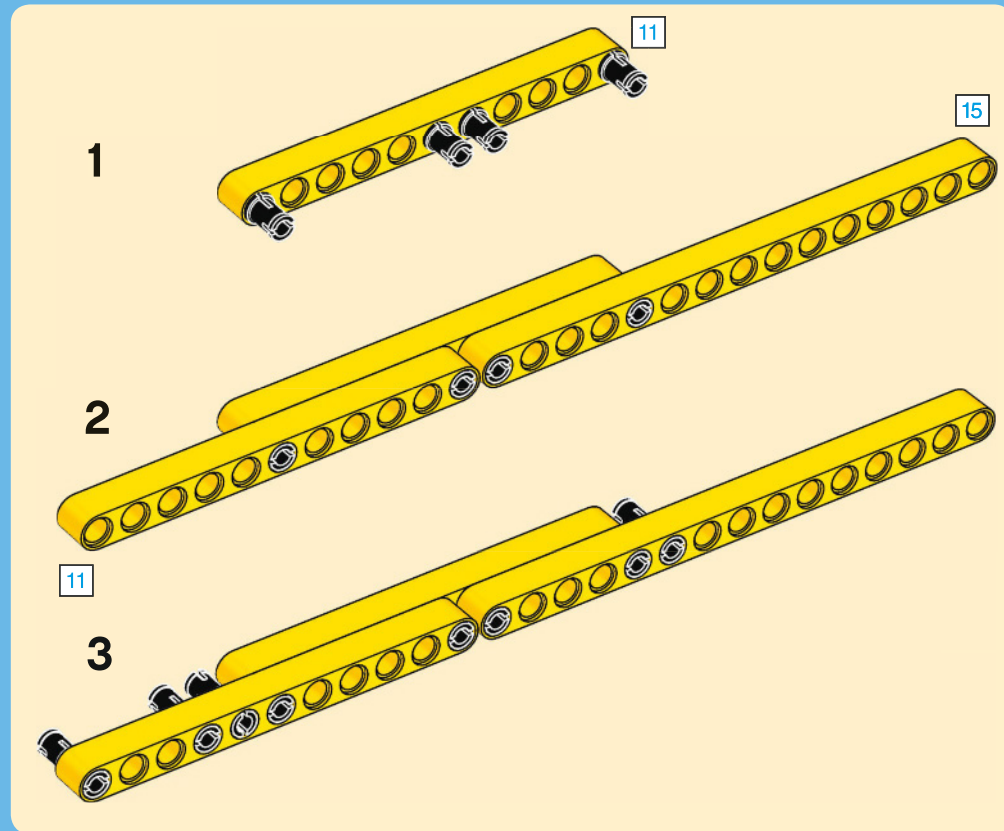



10

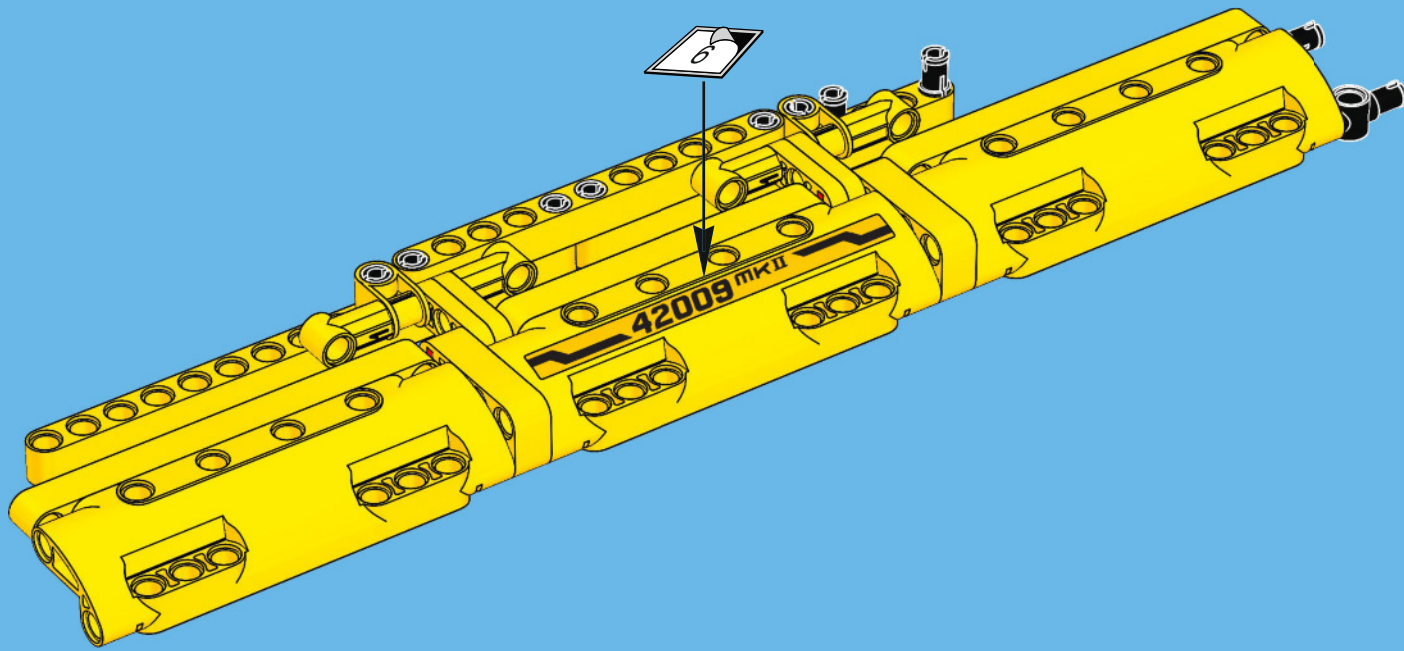

28

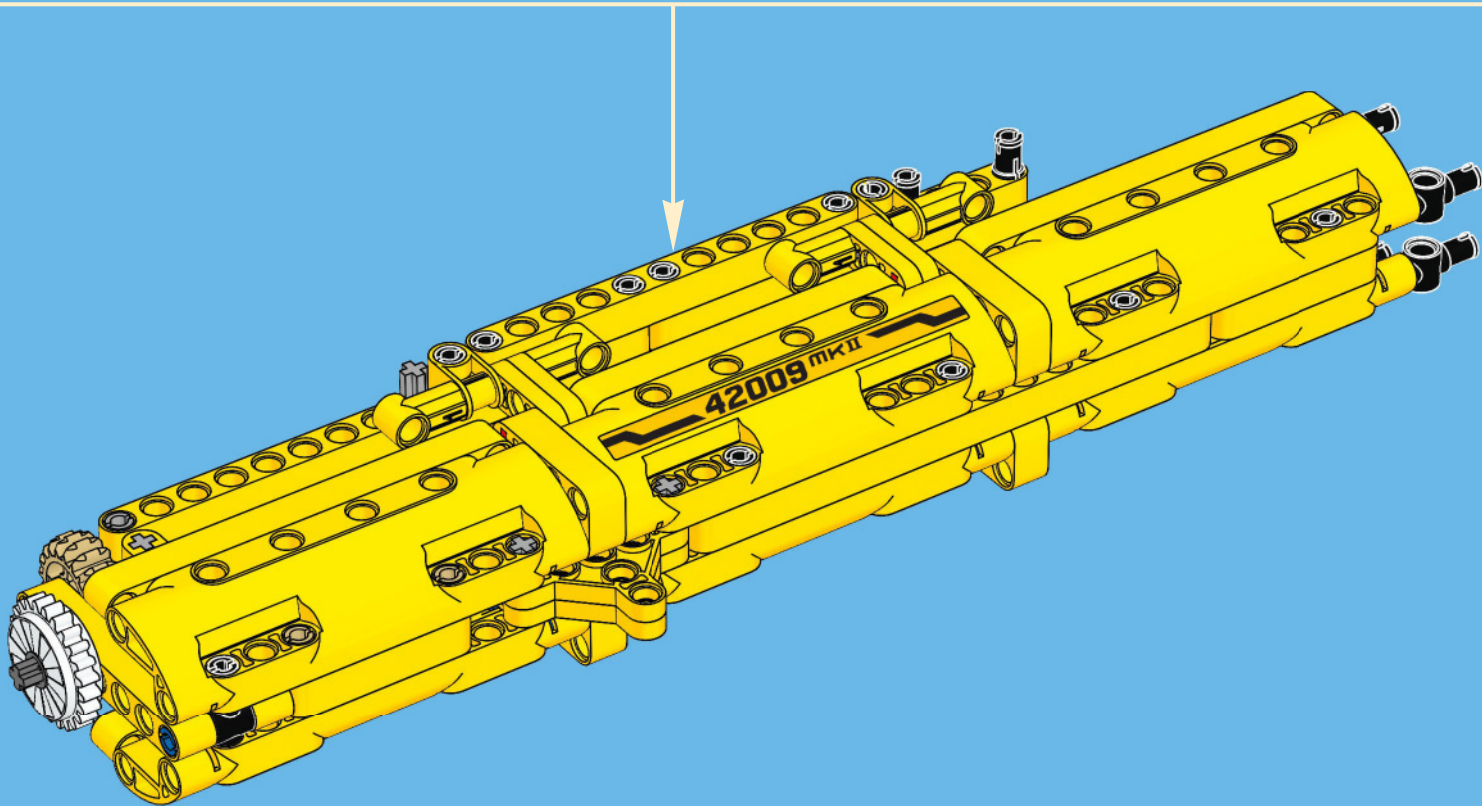

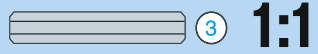
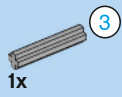

29

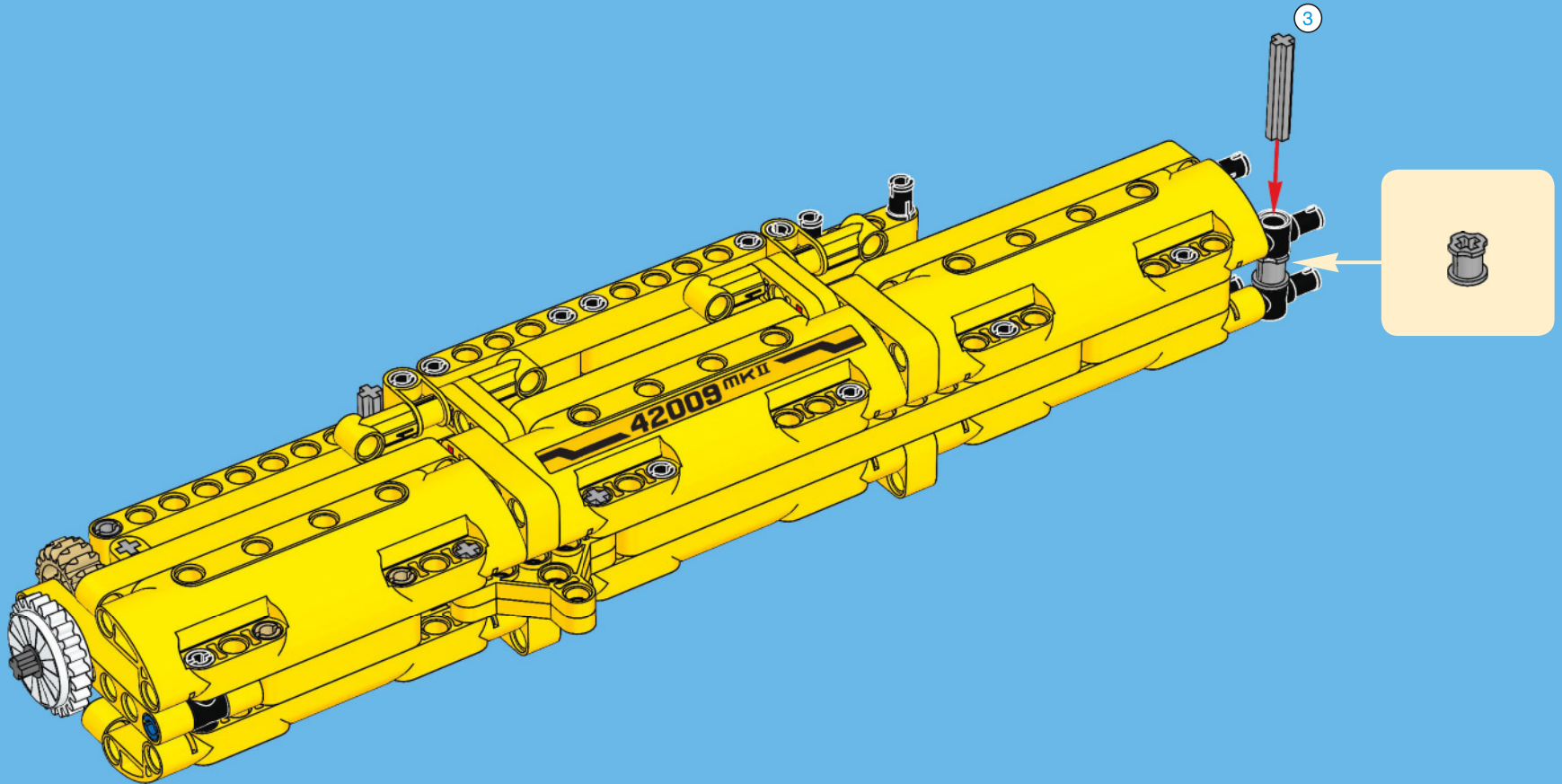



2x



1x

# 30

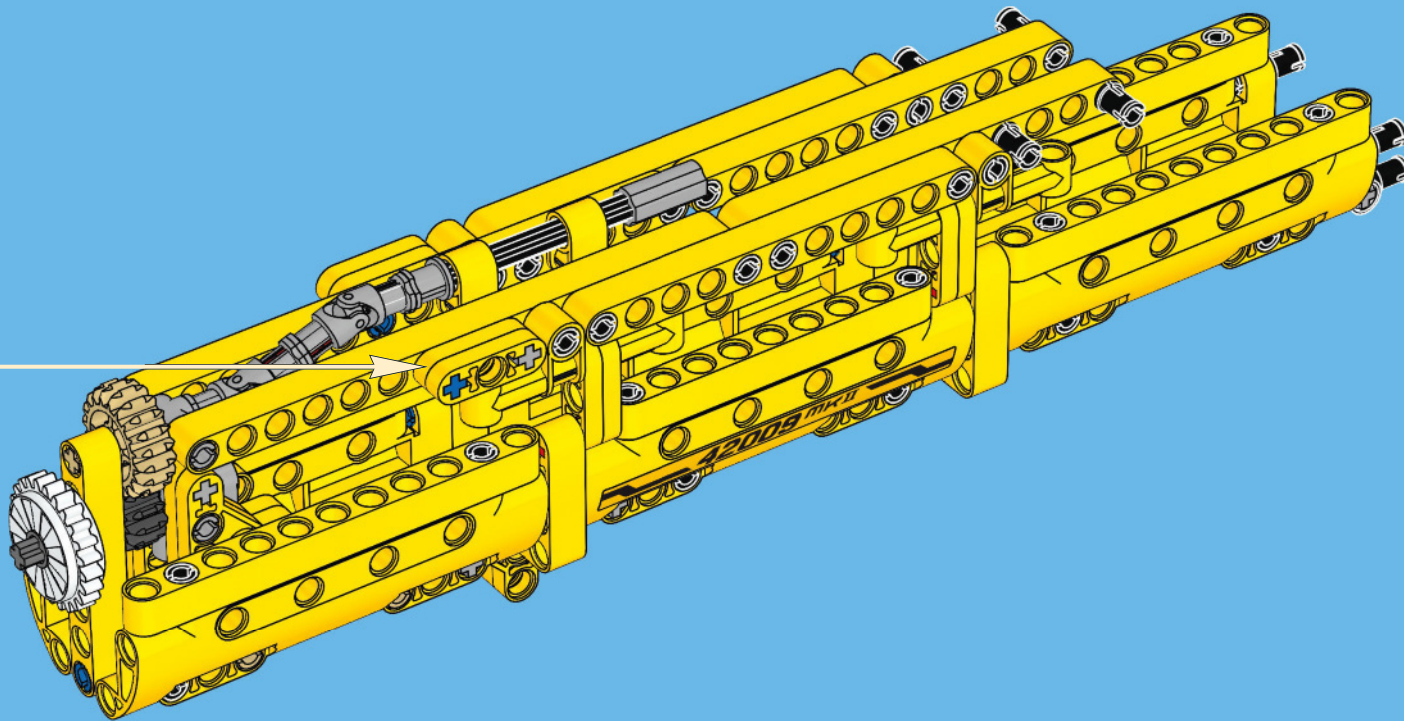
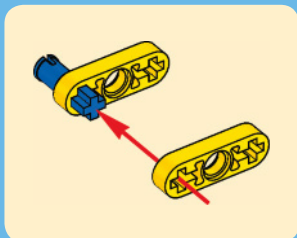

4x



2x

# 31



2x

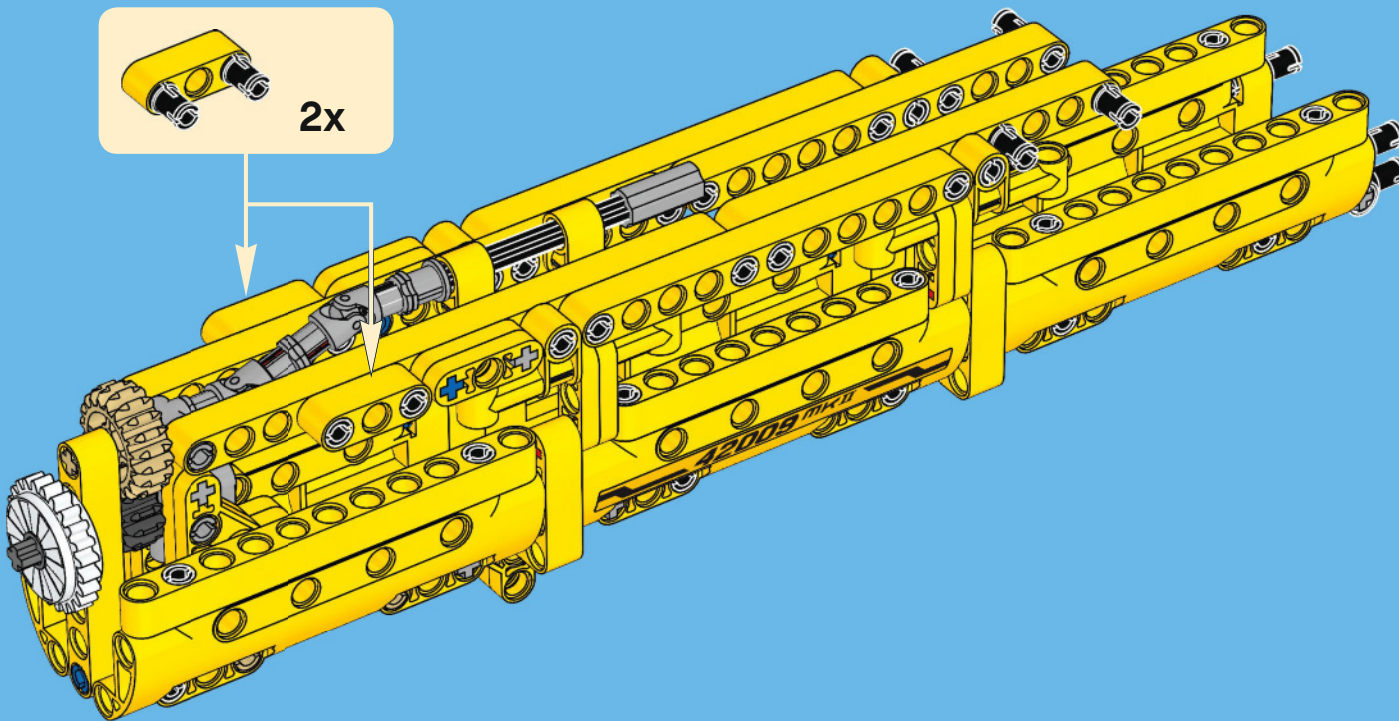



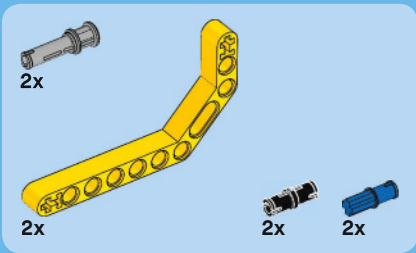

32

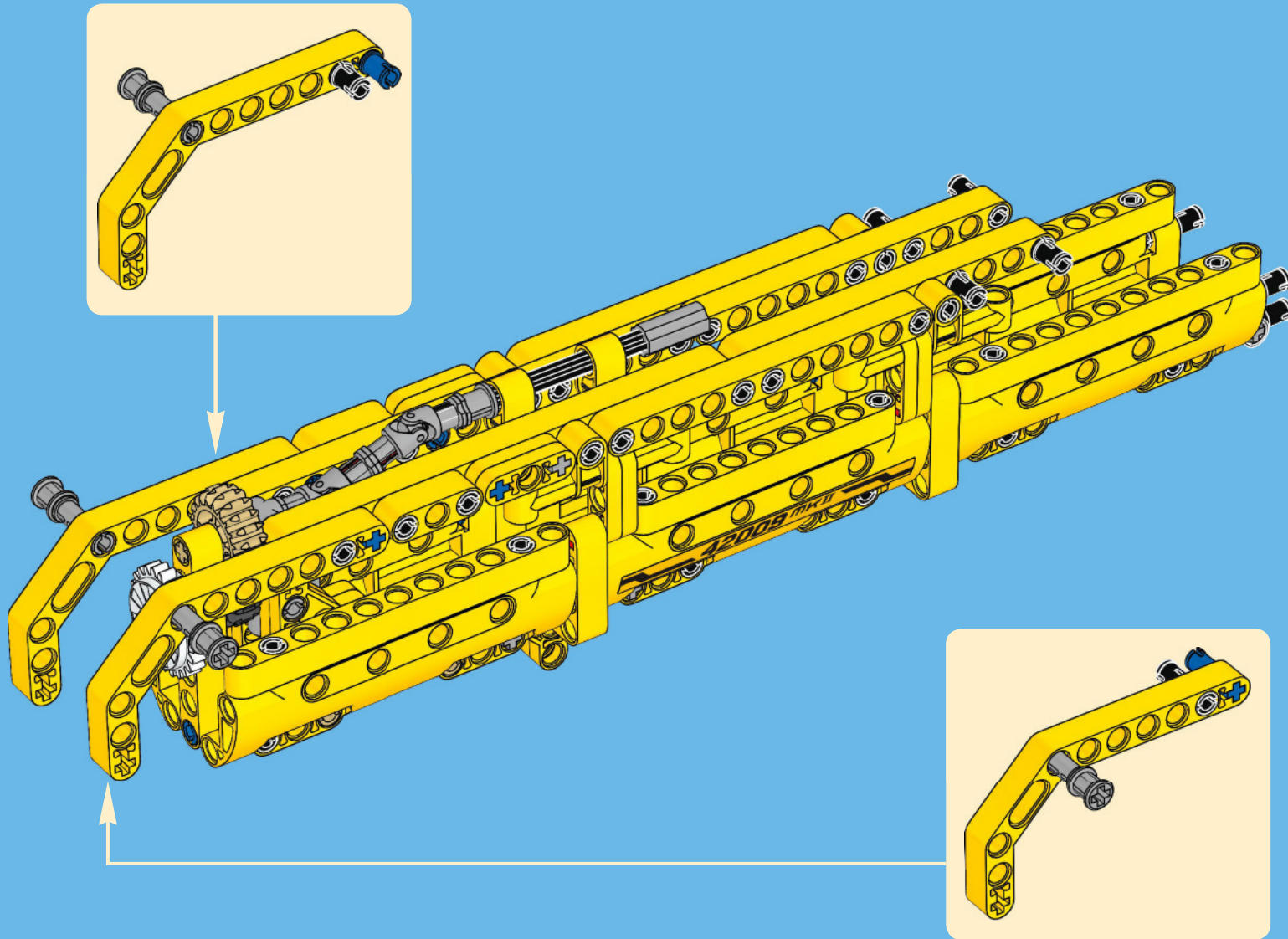

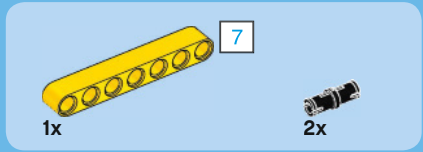
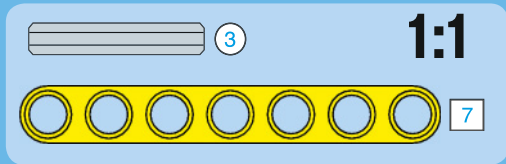
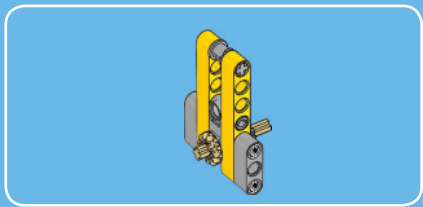

1

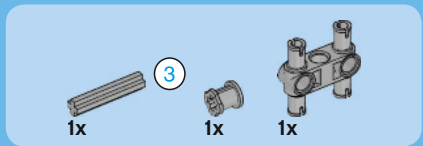

2

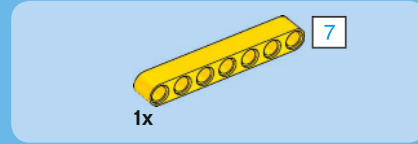
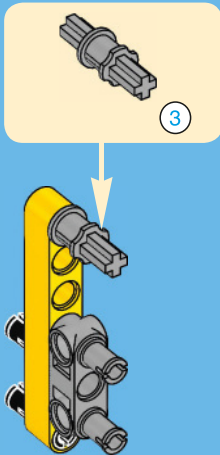

3

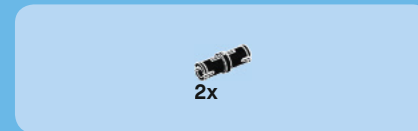
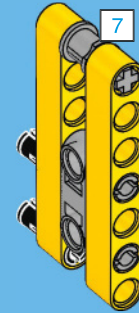

4

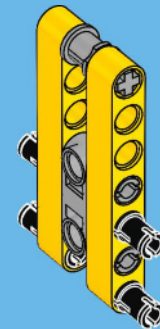



2x

5

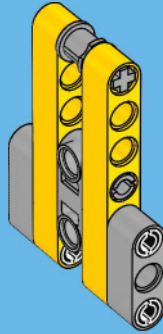

1x

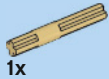

1x



1x

6

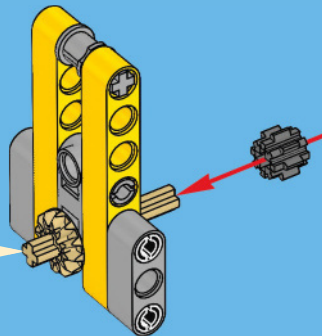
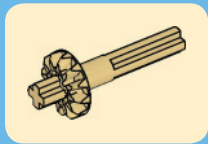

33

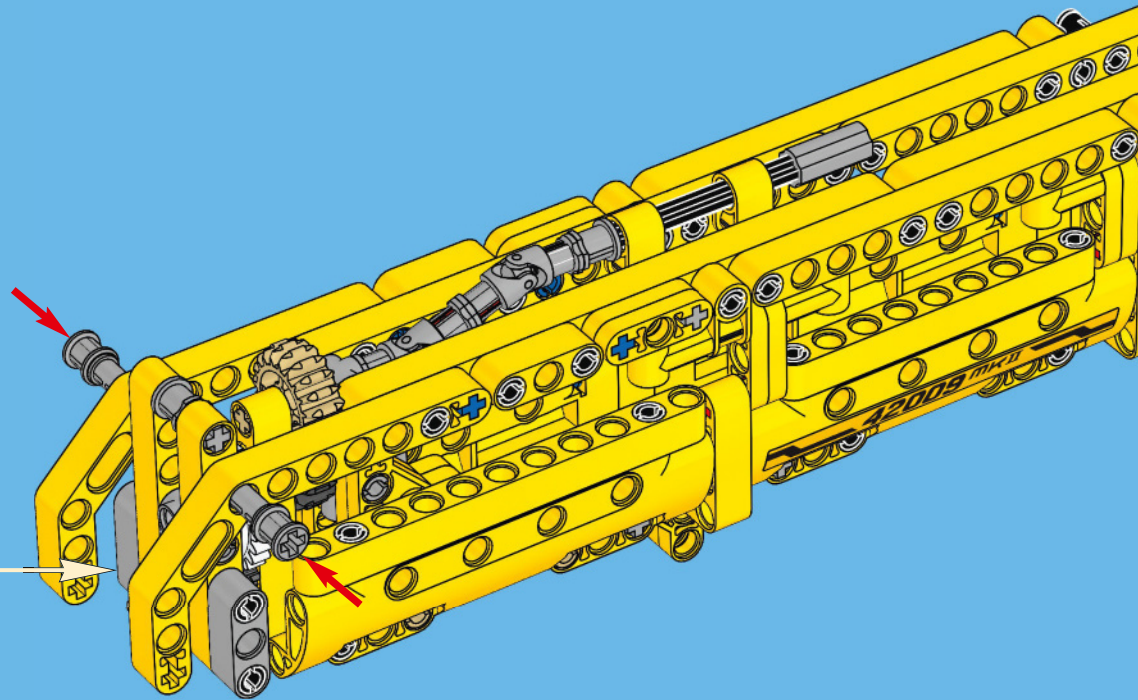



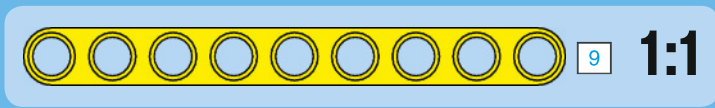
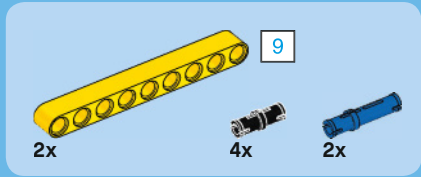

# 34

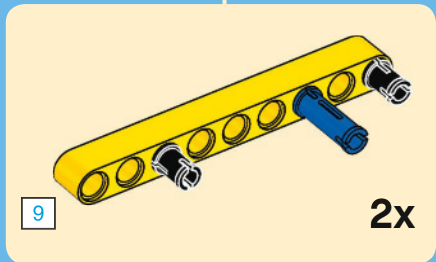
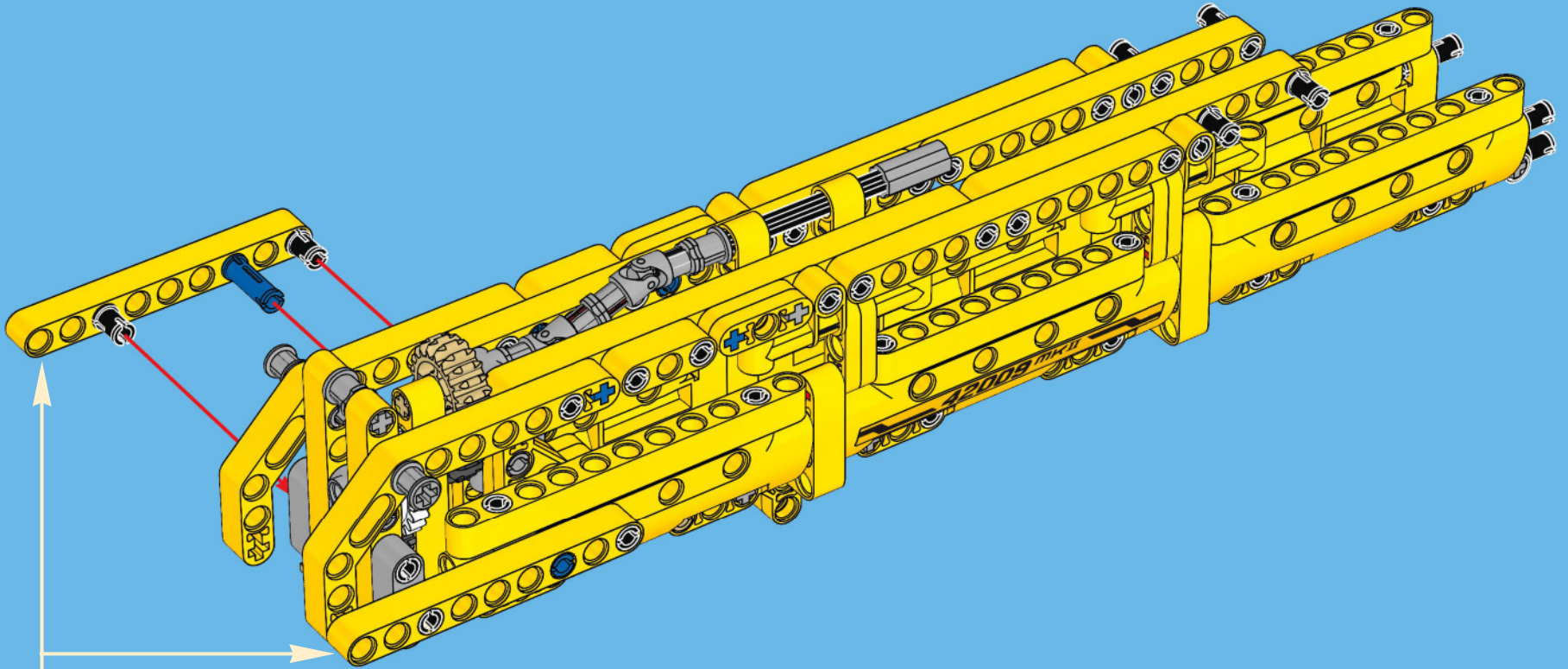

35

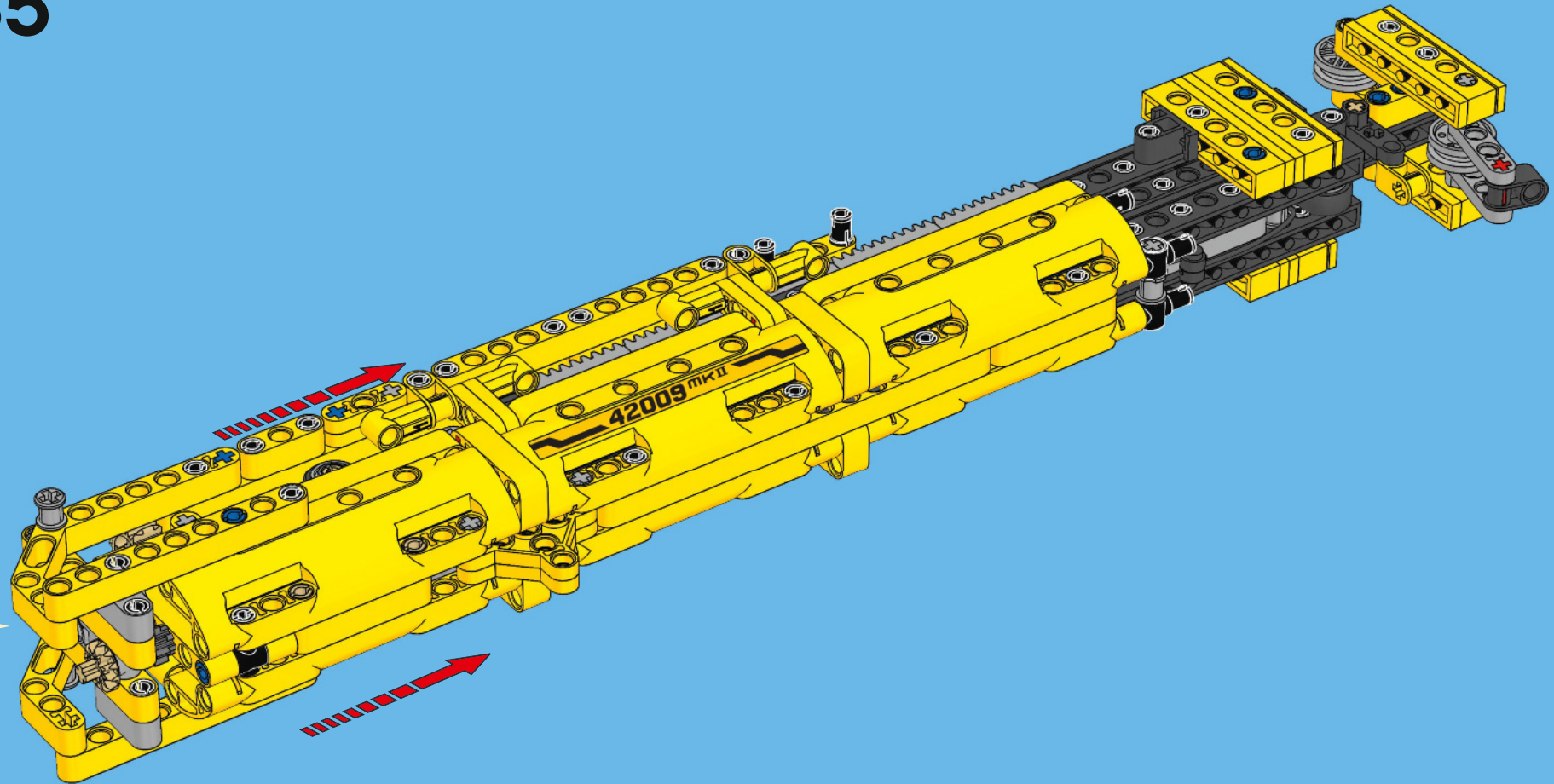

36

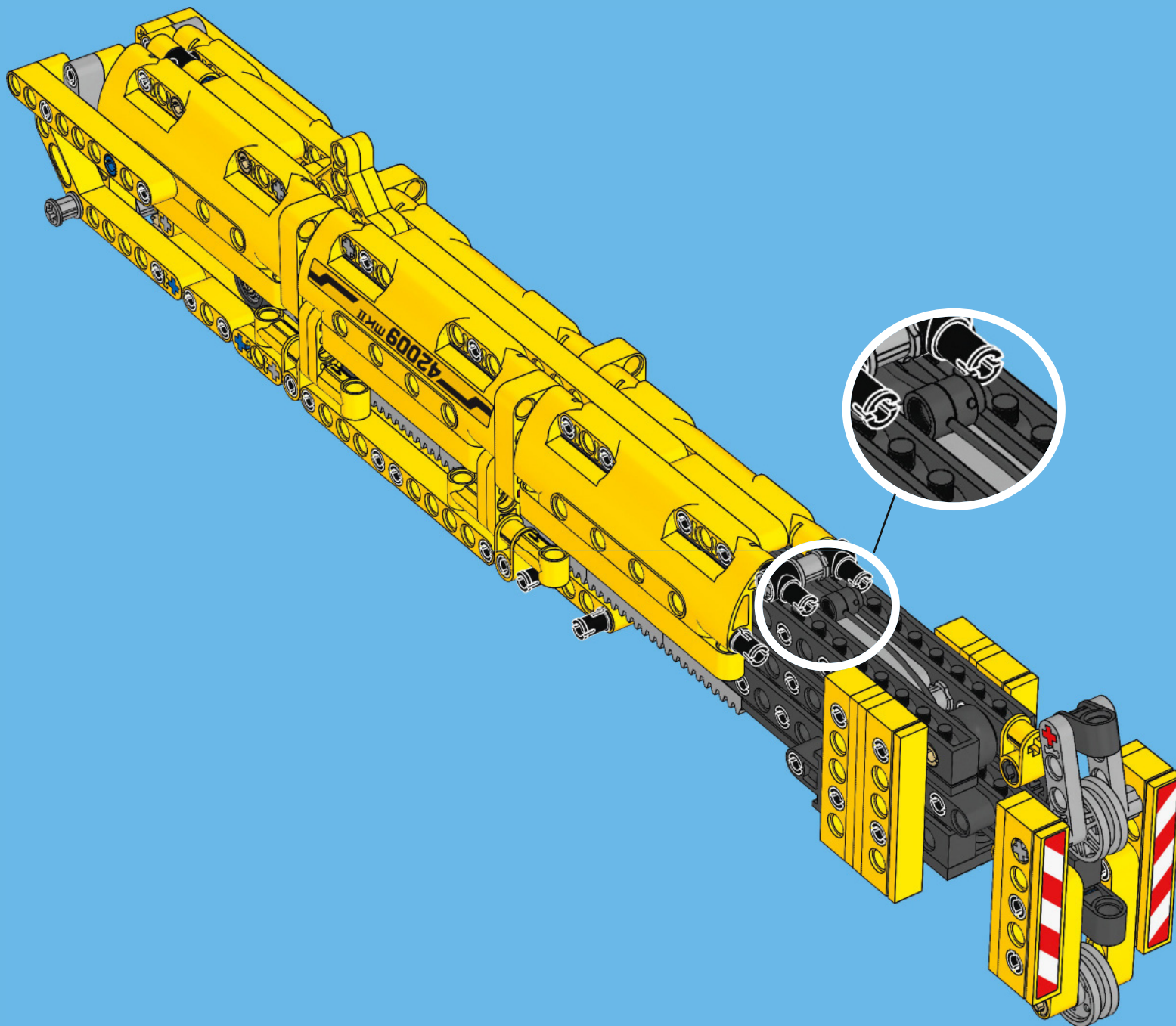



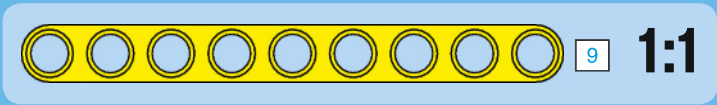
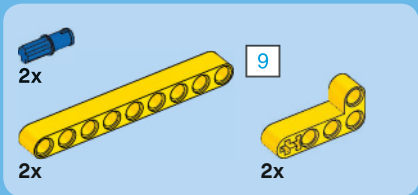

37

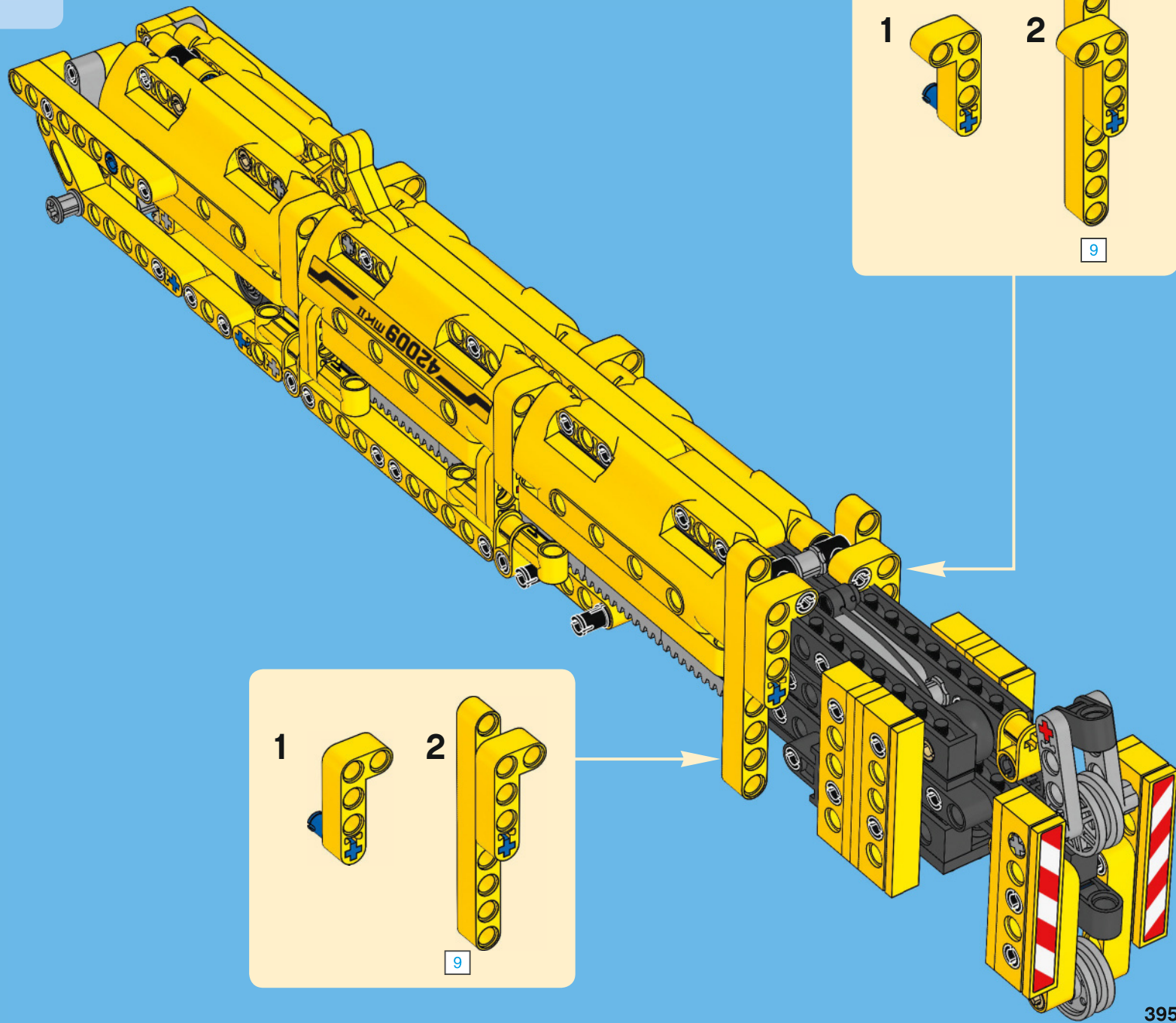

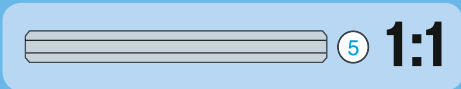
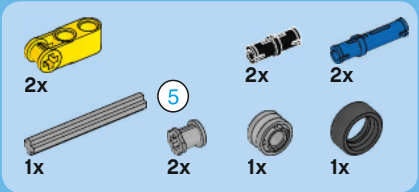

38

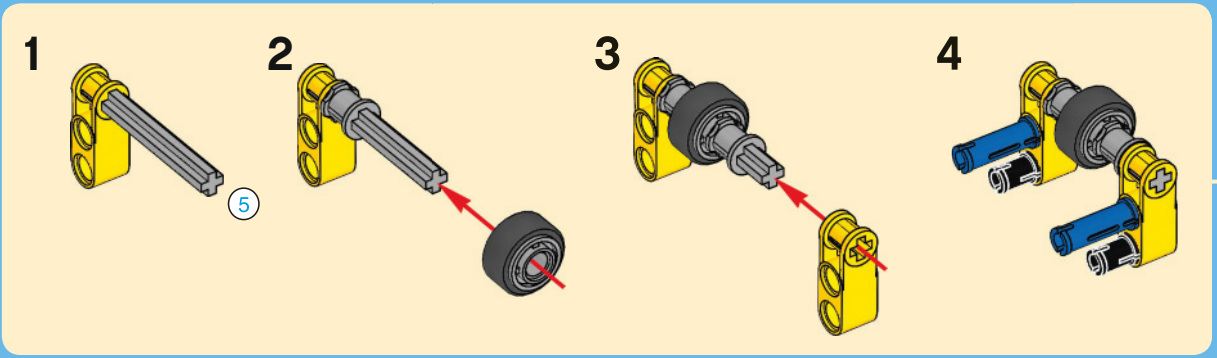
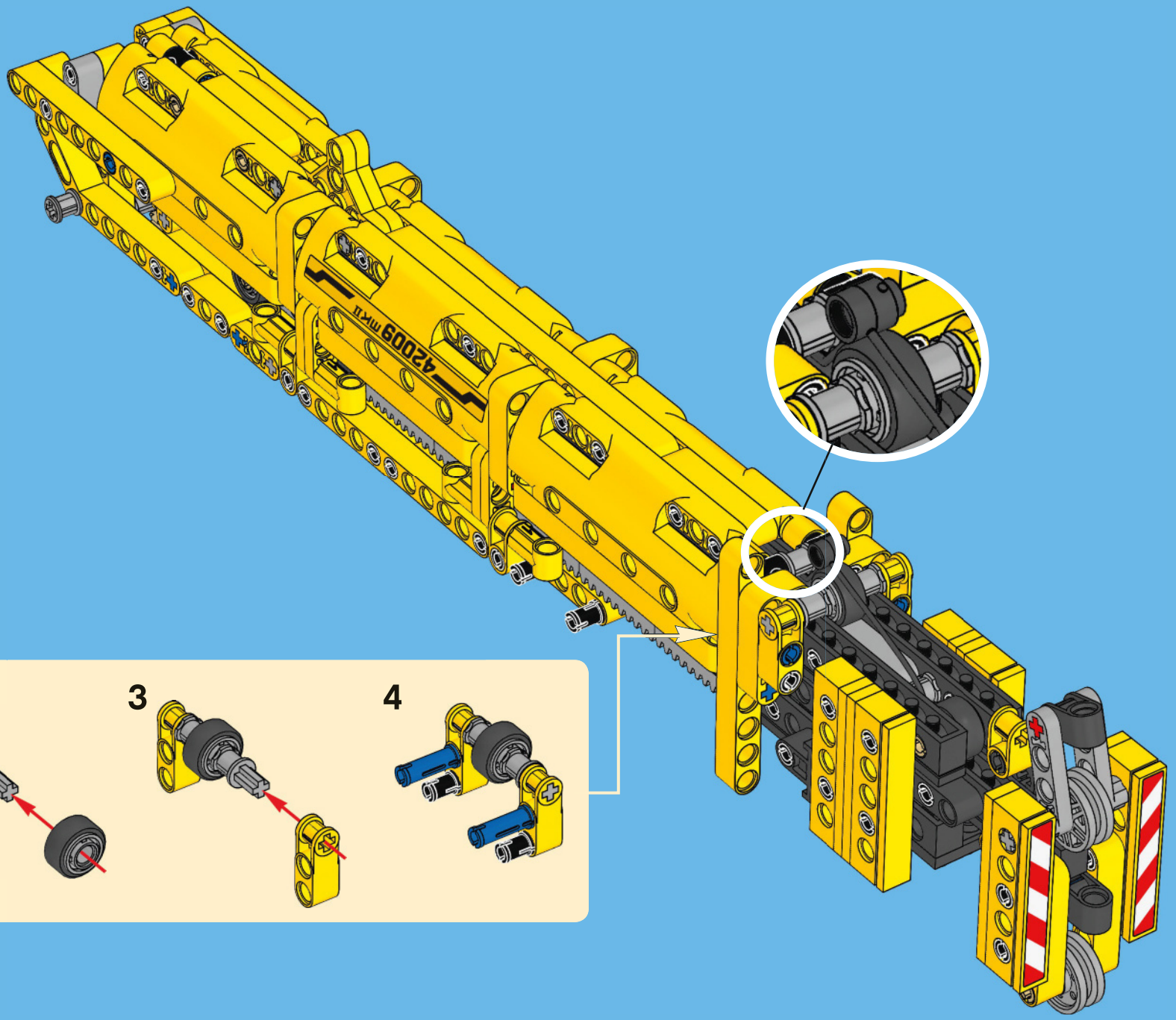

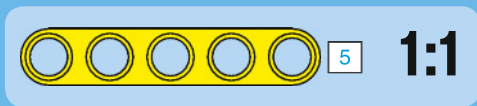

# 39

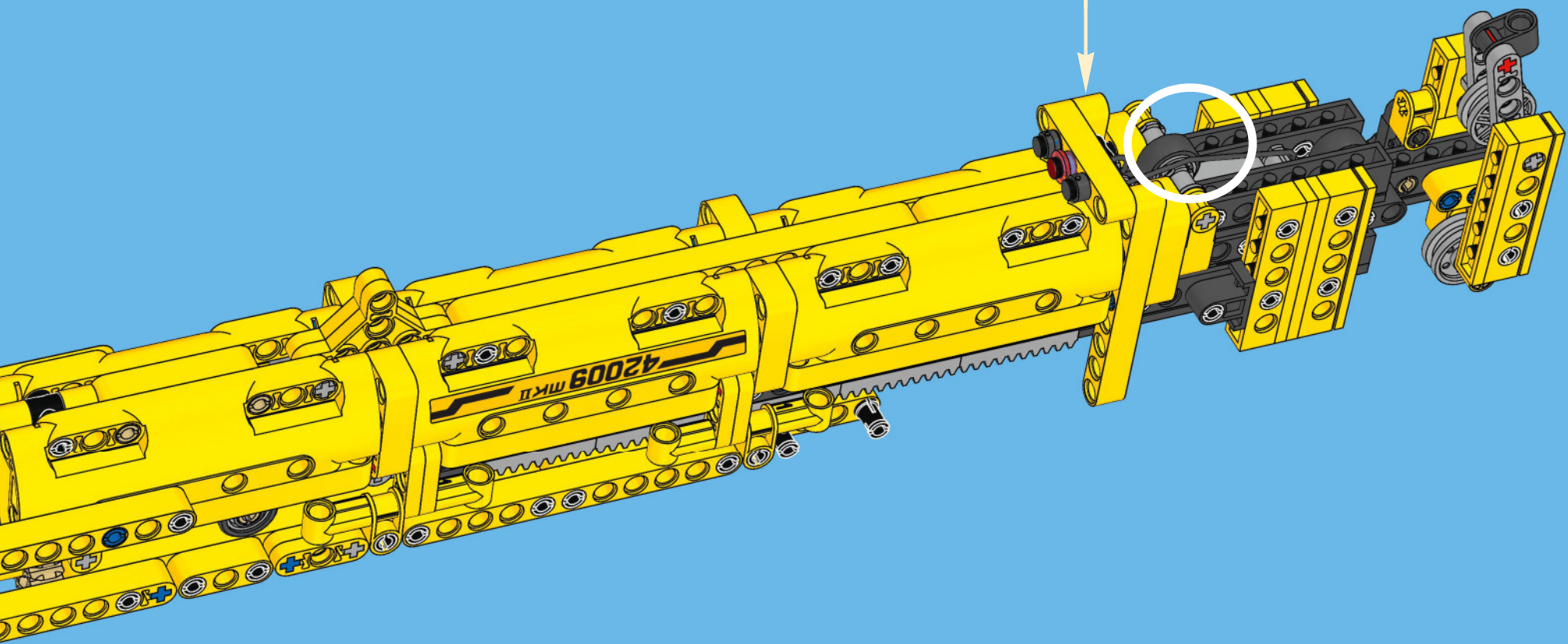
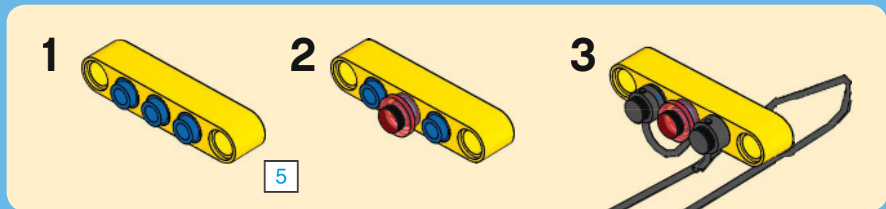





2x



1x

# 40

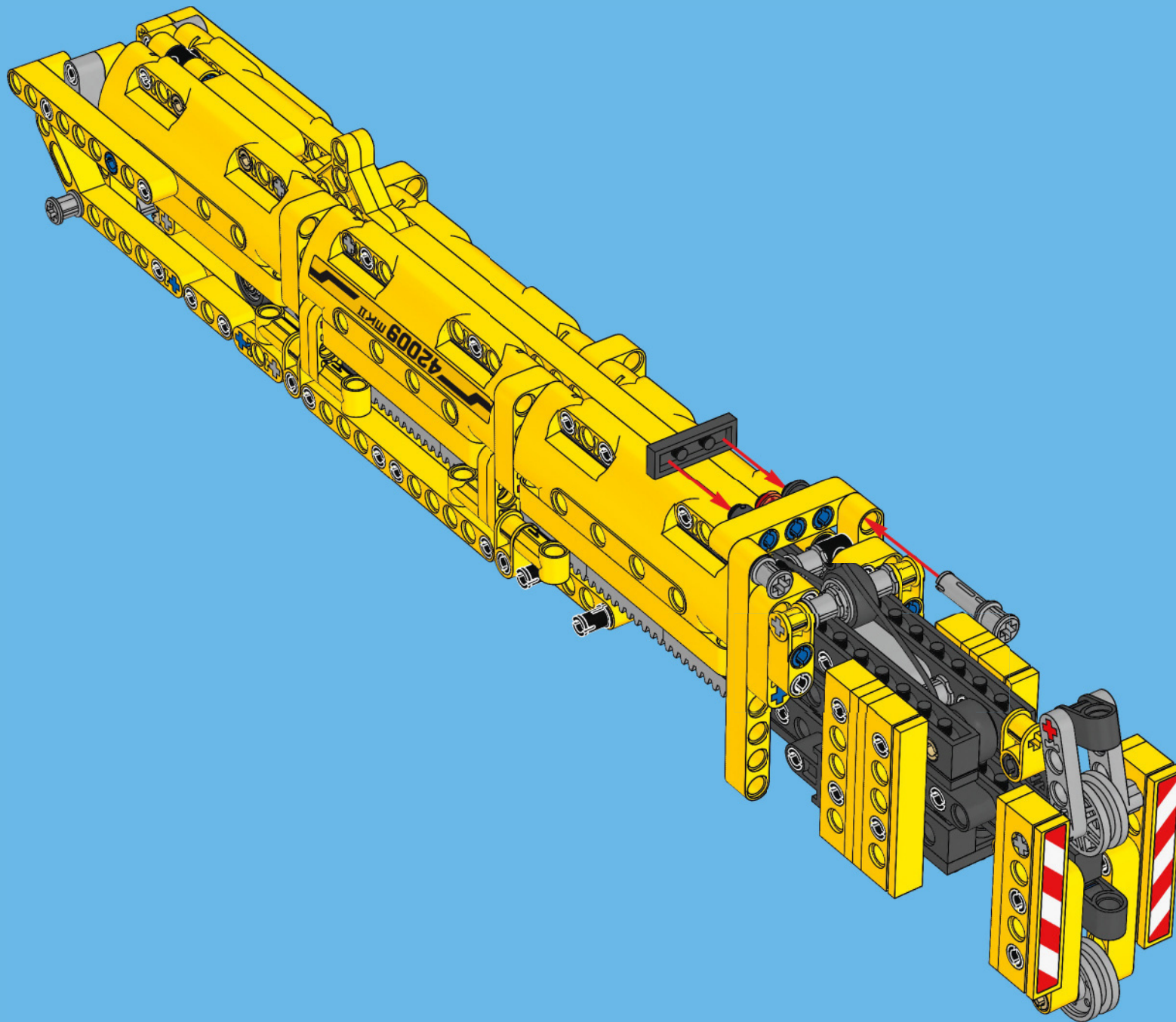

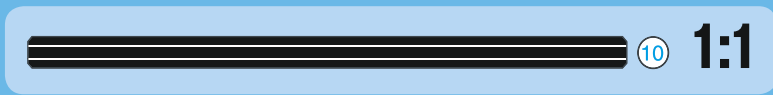
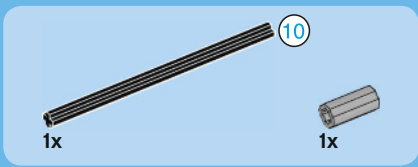

41

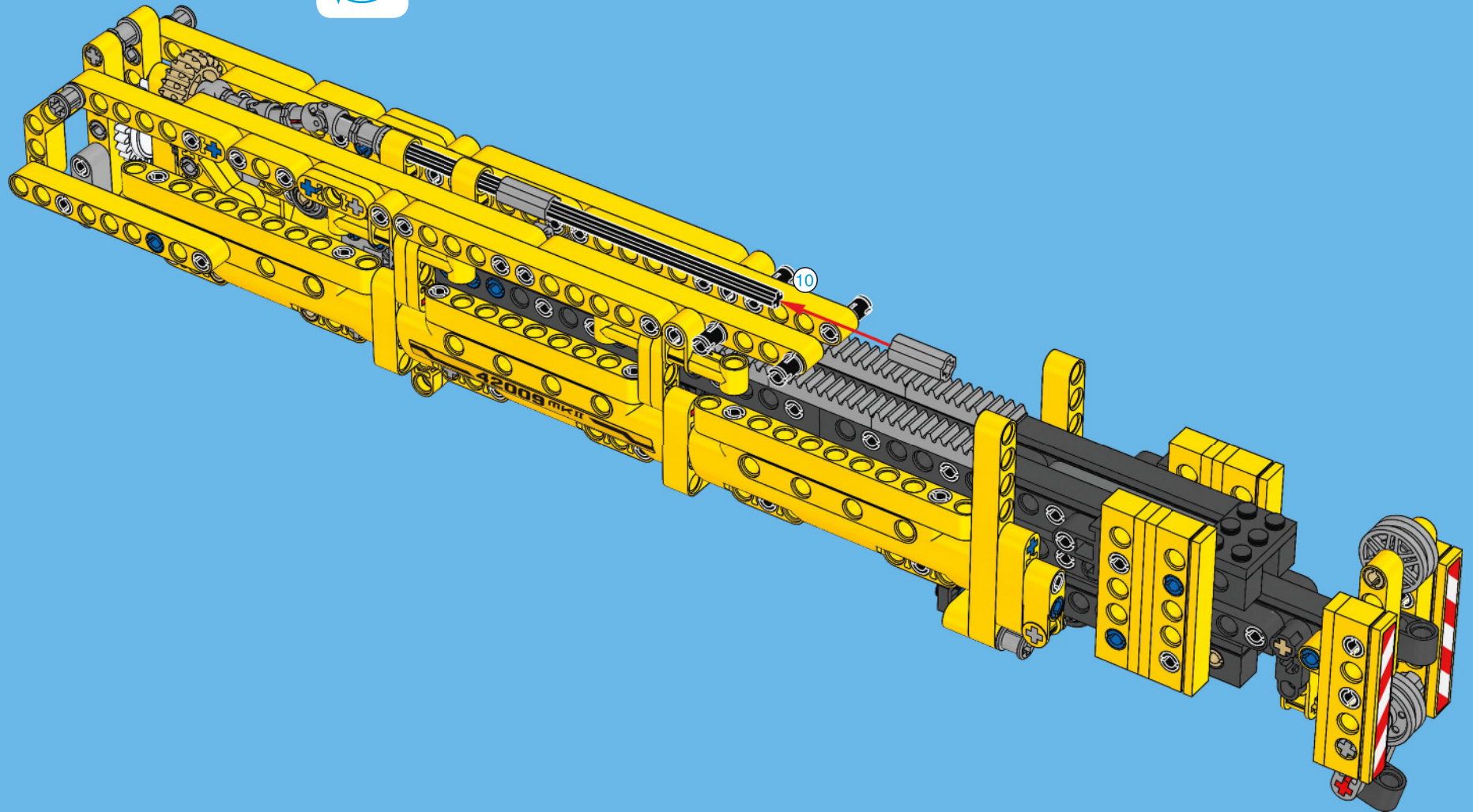

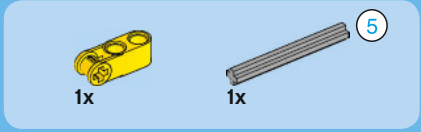
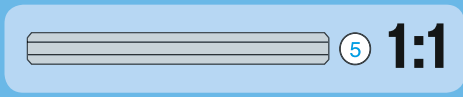
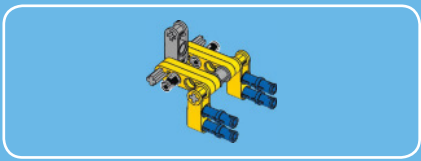

1

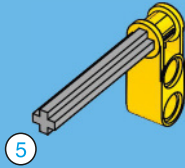

2

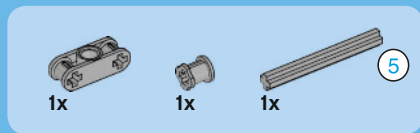
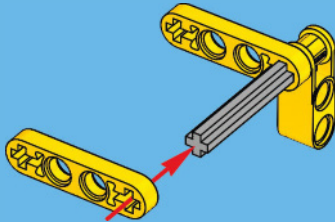

3

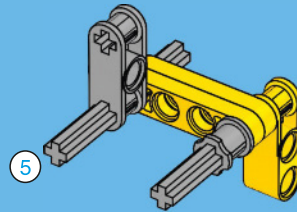

4

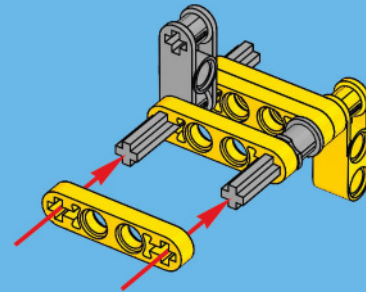



2x

1x

5

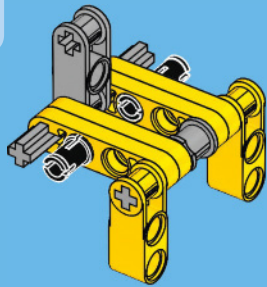

4x

6

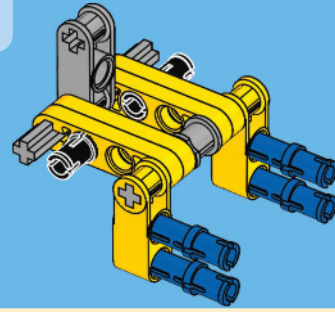

42

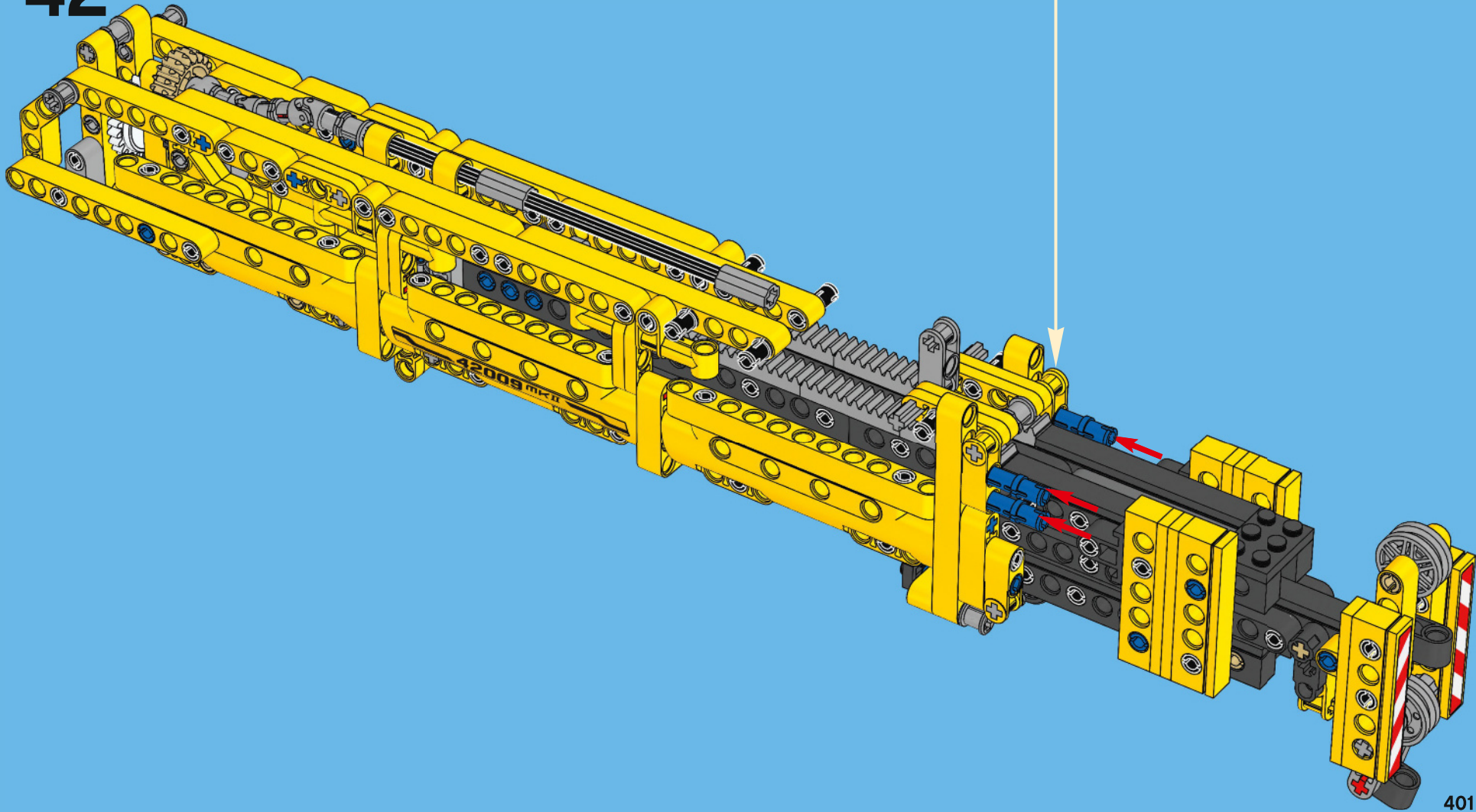

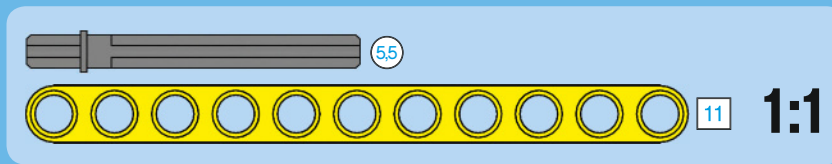
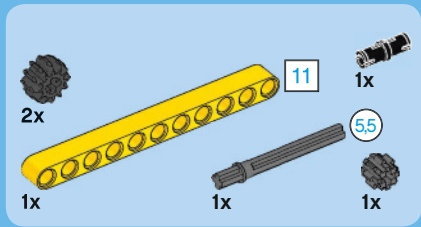

43

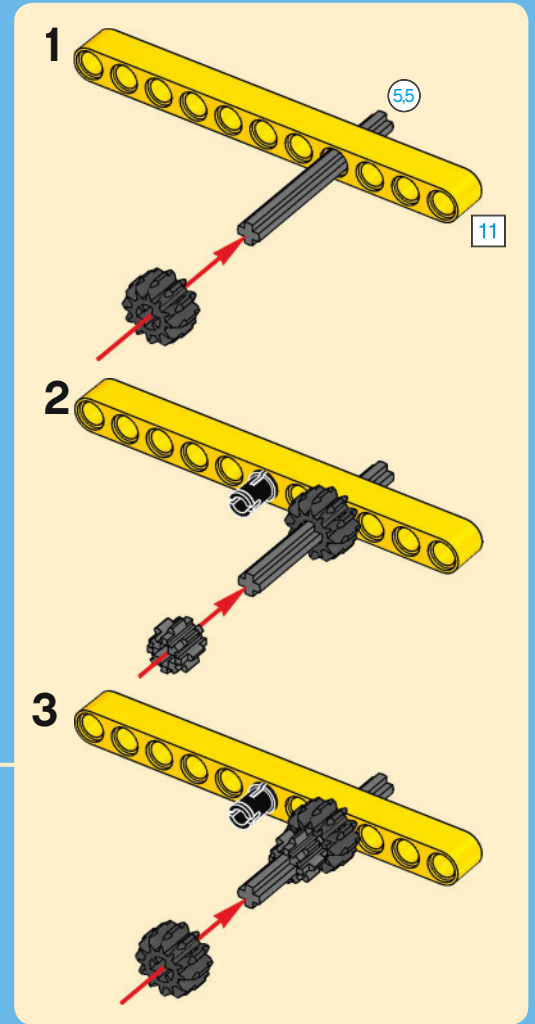
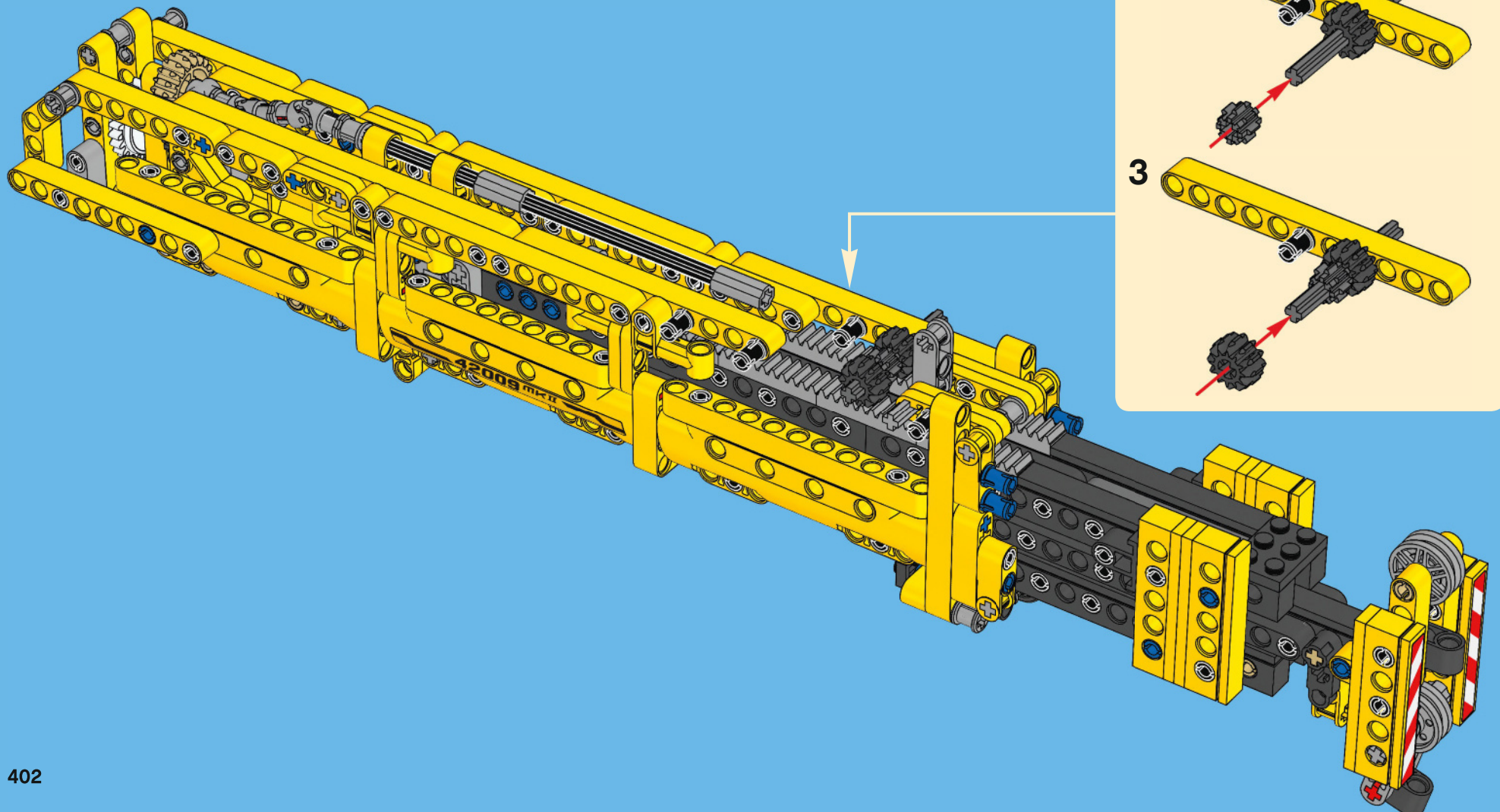



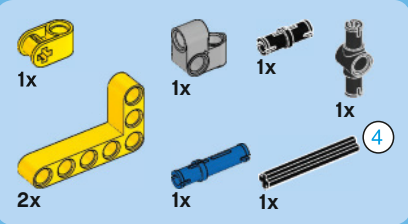

44

Step-by-step assembly sequence for step 44:

1. Attach a grey bush to the end of a yellow L-shaped beam.
2. Attach a blue pin to the bush.
3. Attach a second yellow L-shaped beam to the assembly. Red arrows indicate alignment points.
4. Attach a grey bush with an axle to the end of the second beam. A blue pin with a '4' in a circle is shown being inserted into the bush.

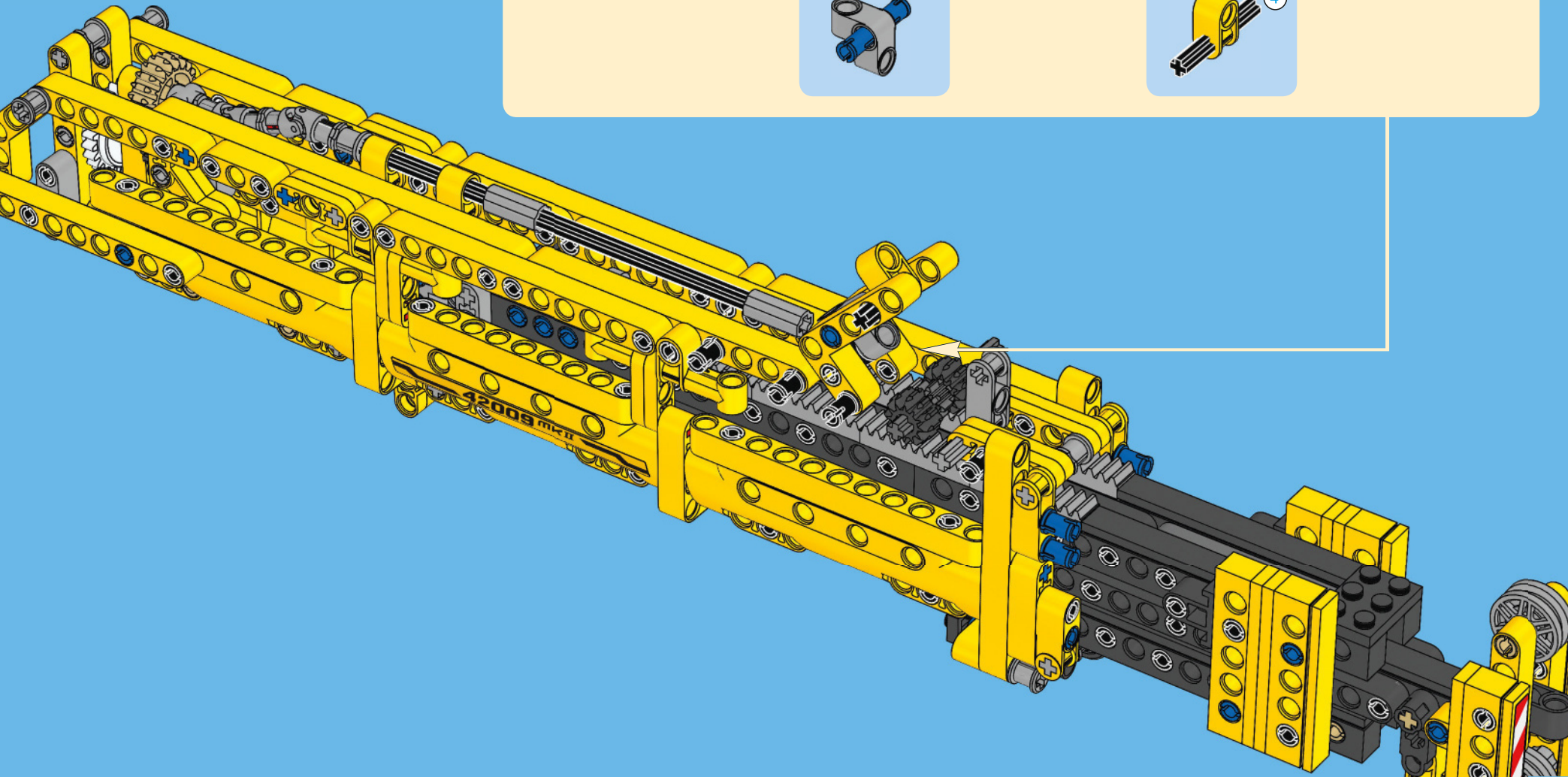



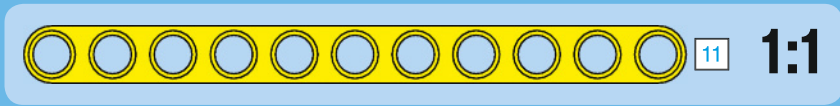
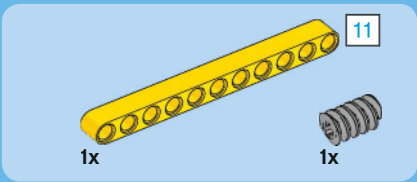

45

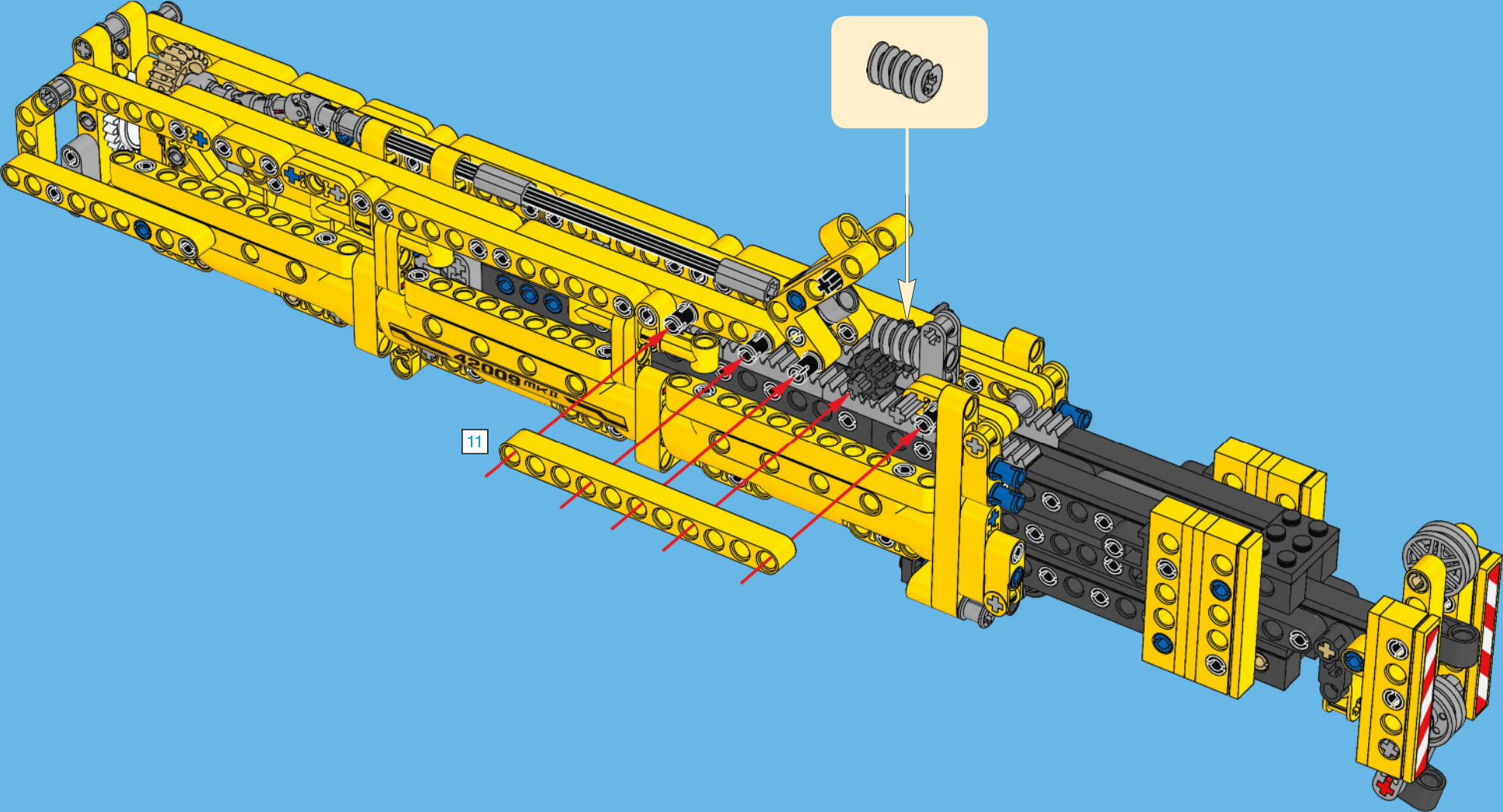

46

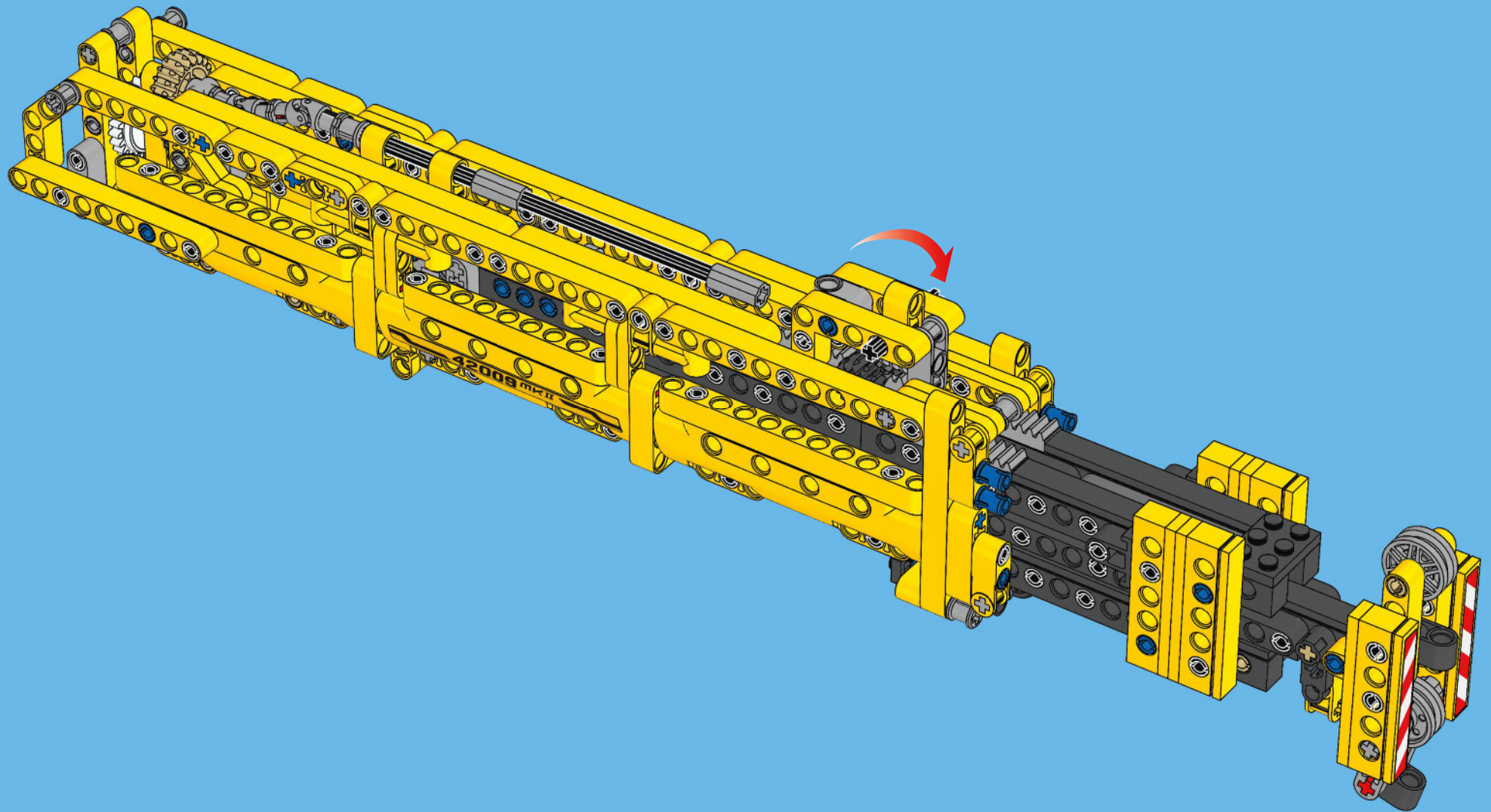

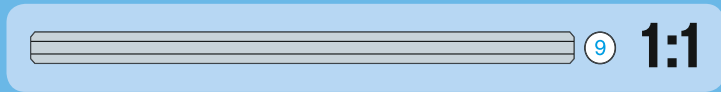
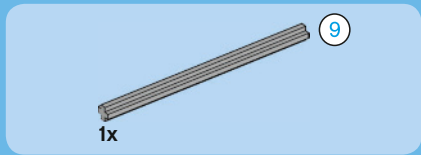

47

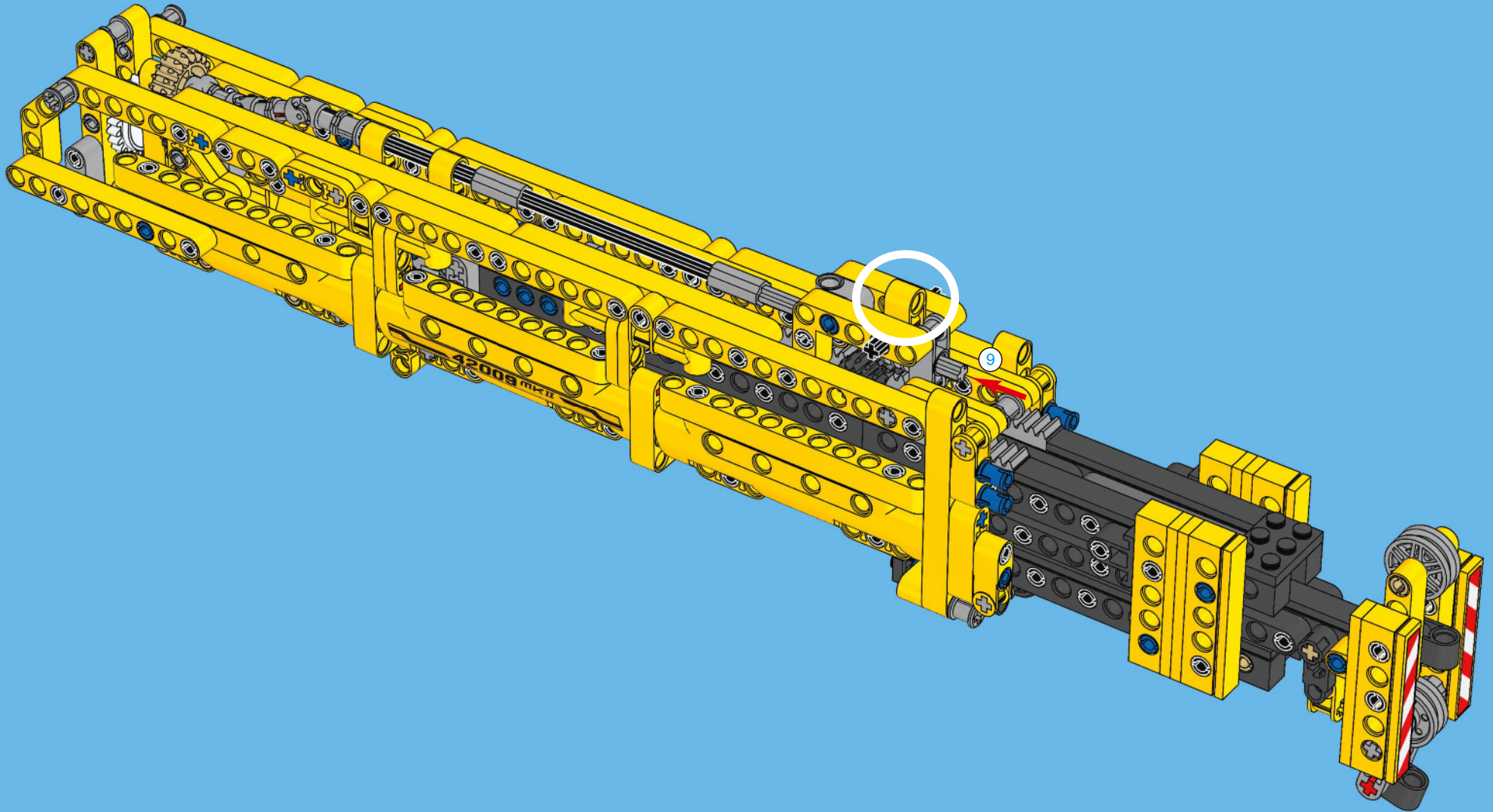



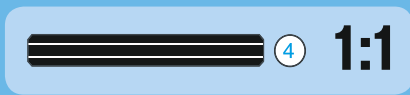
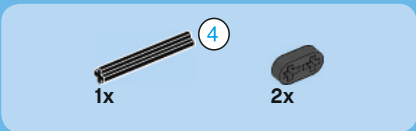

48

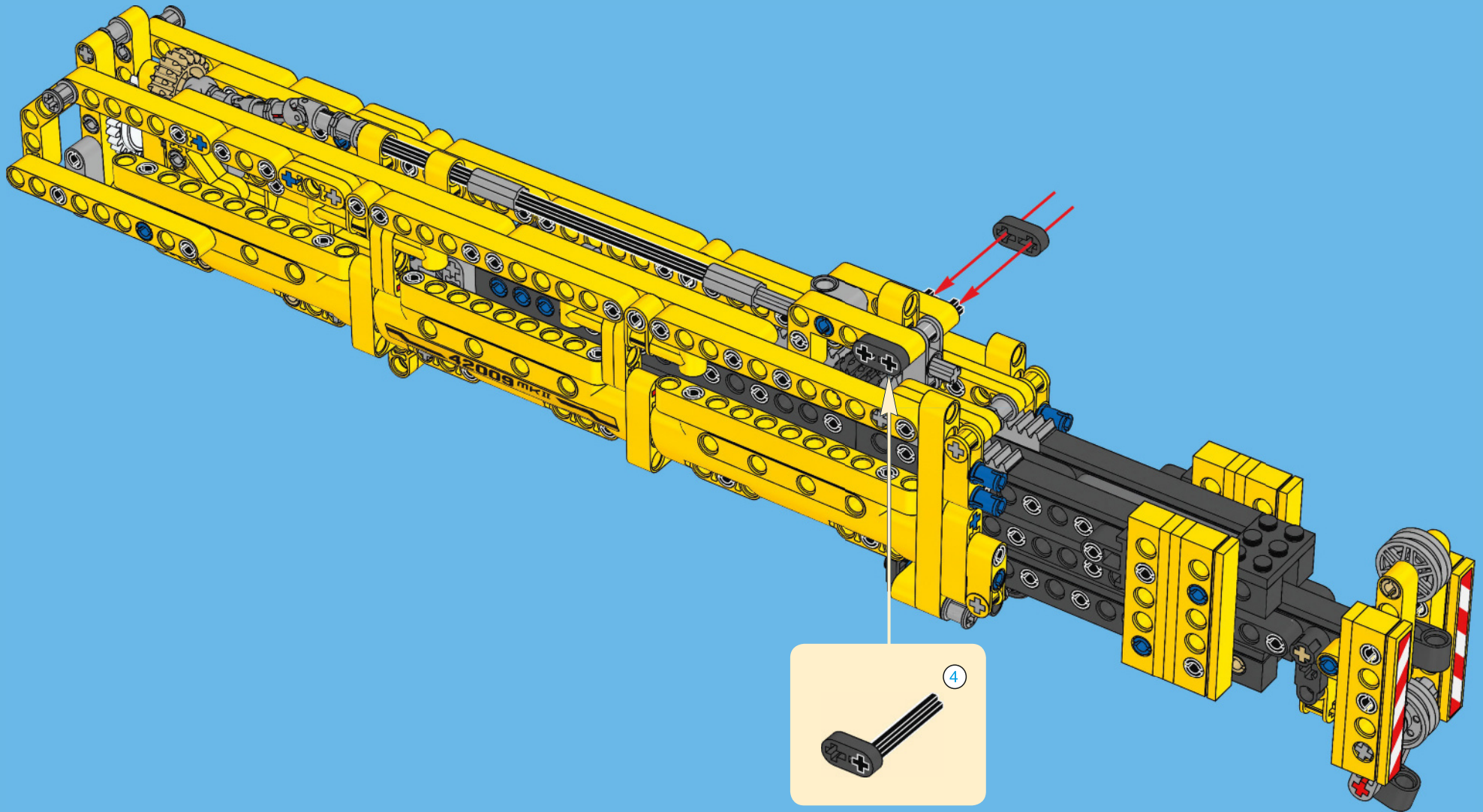

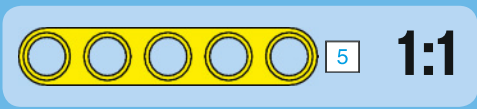
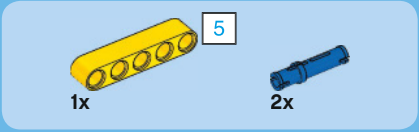

# 49

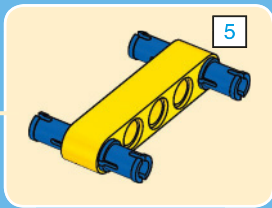
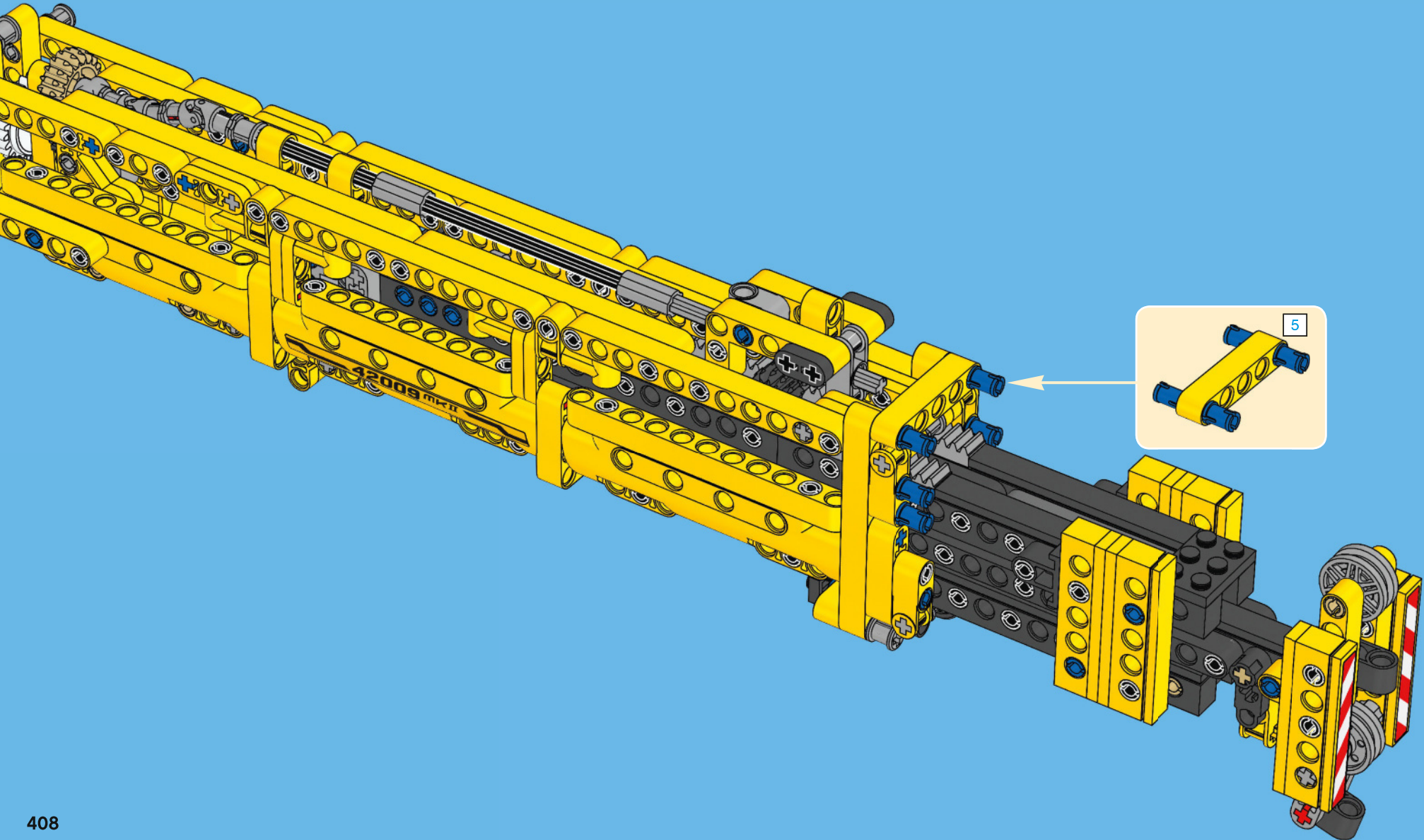

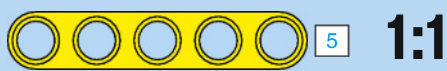
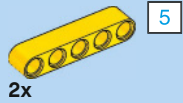

50

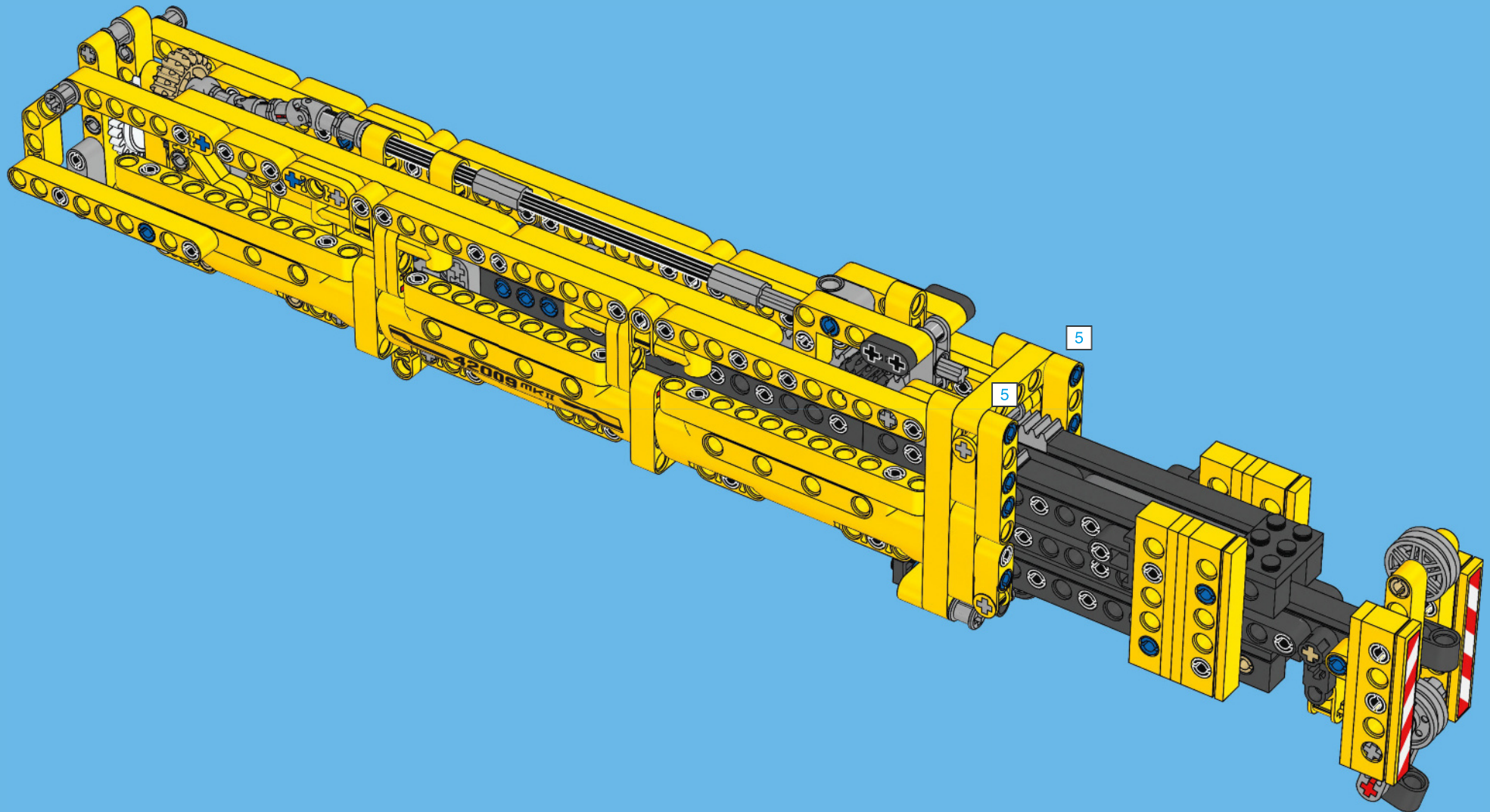



6x

2x

# 51

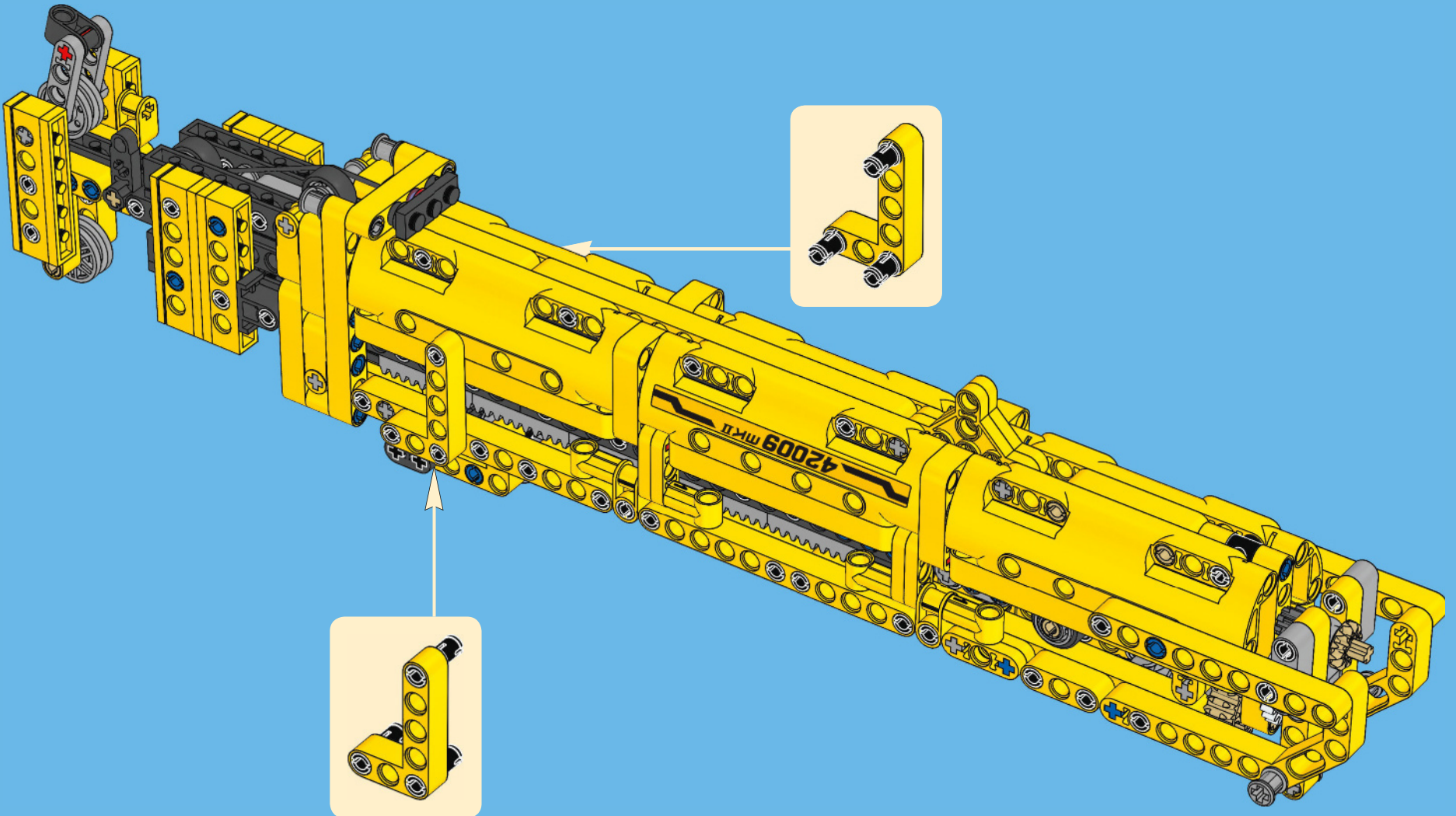

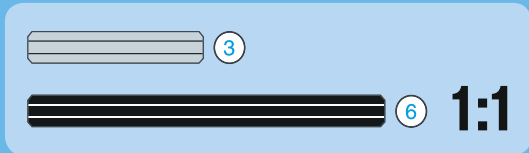
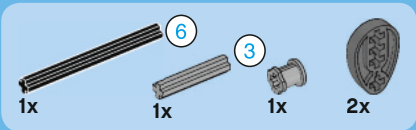

52

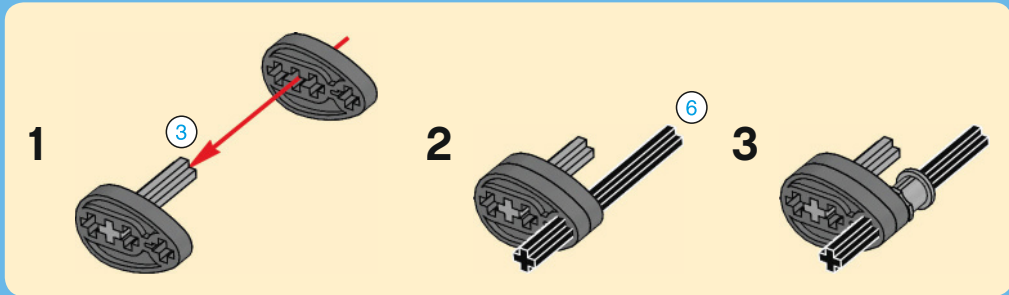
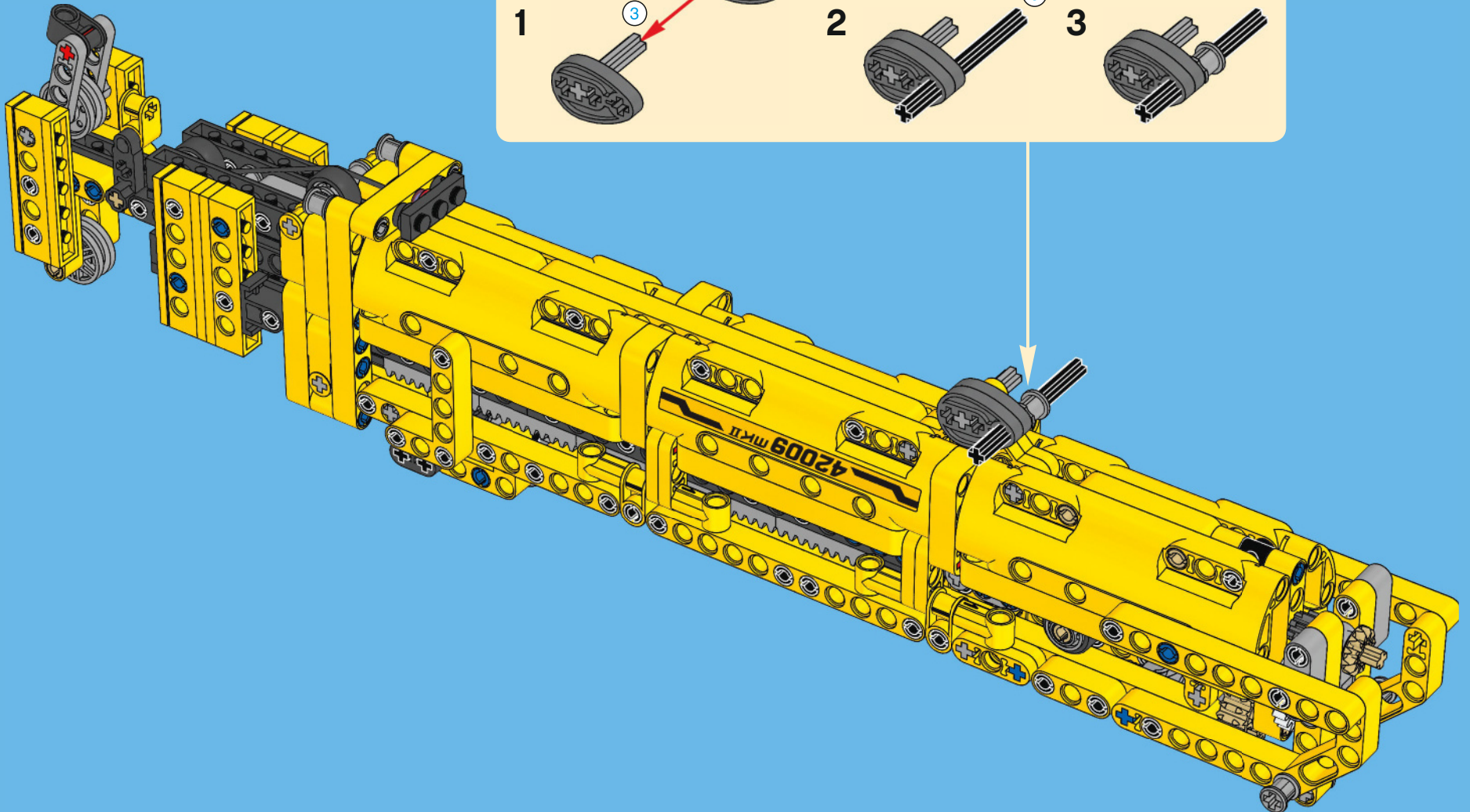





2x

53

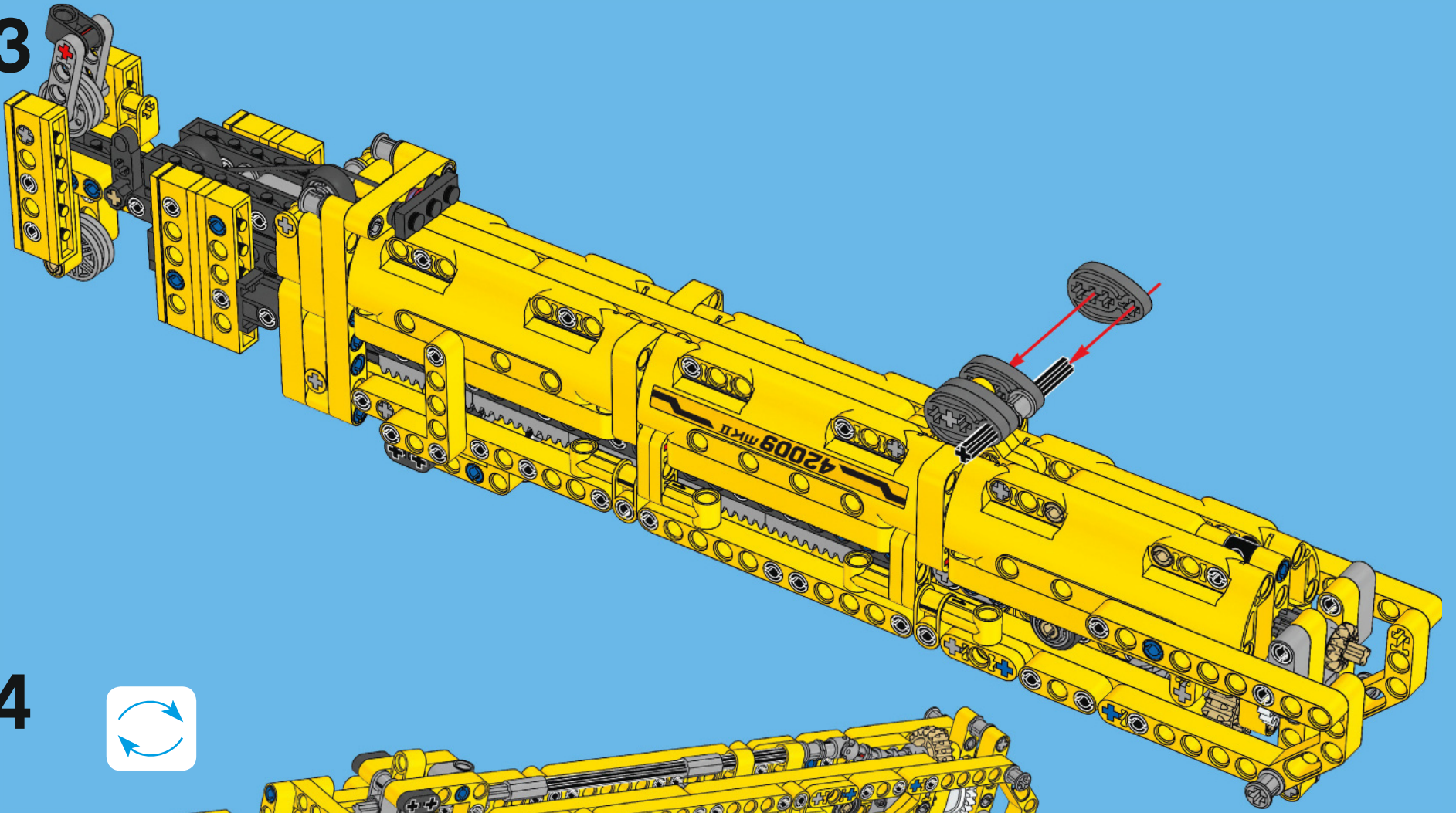

54

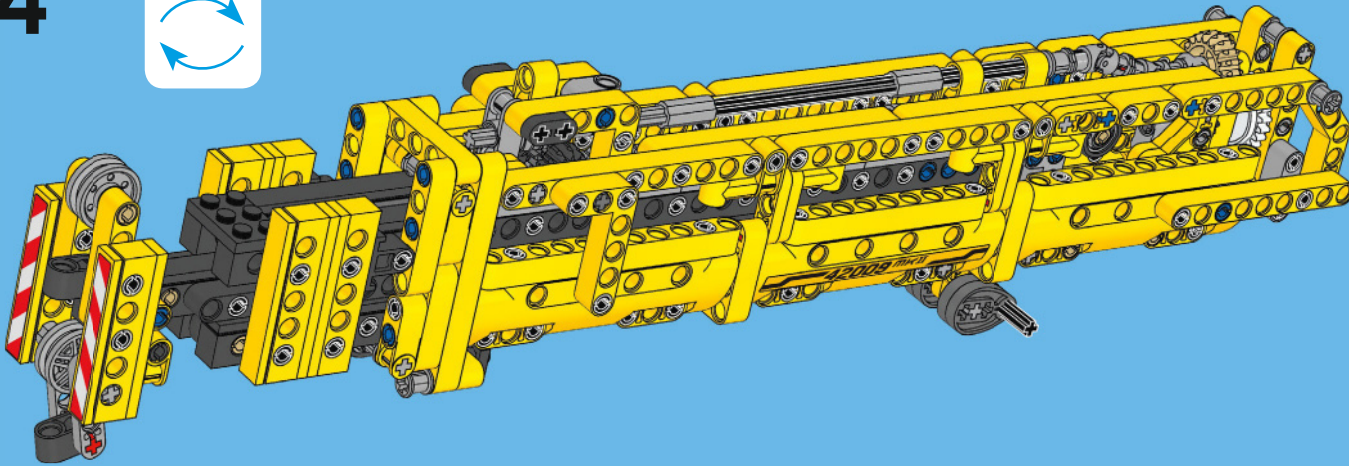



55

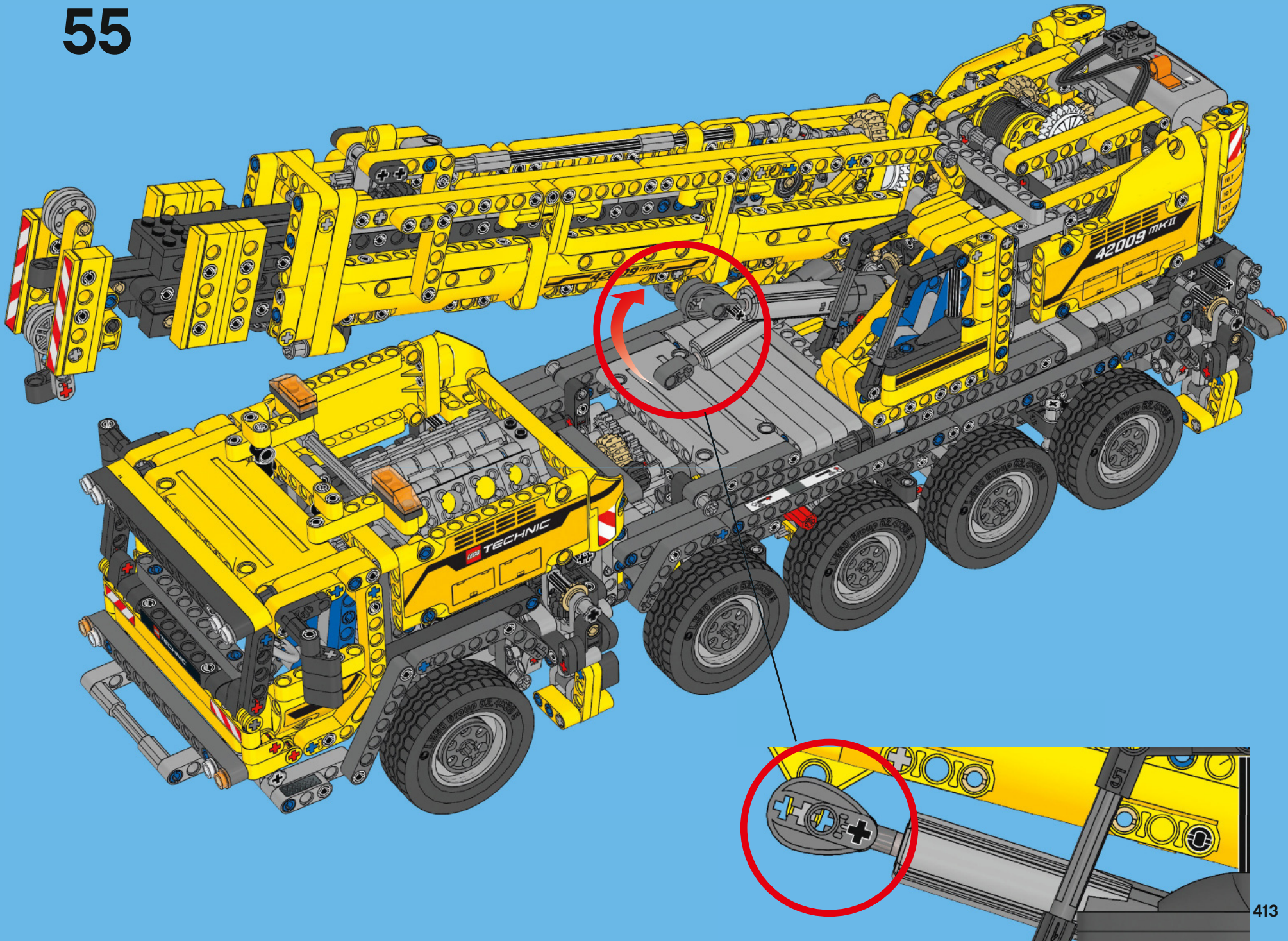



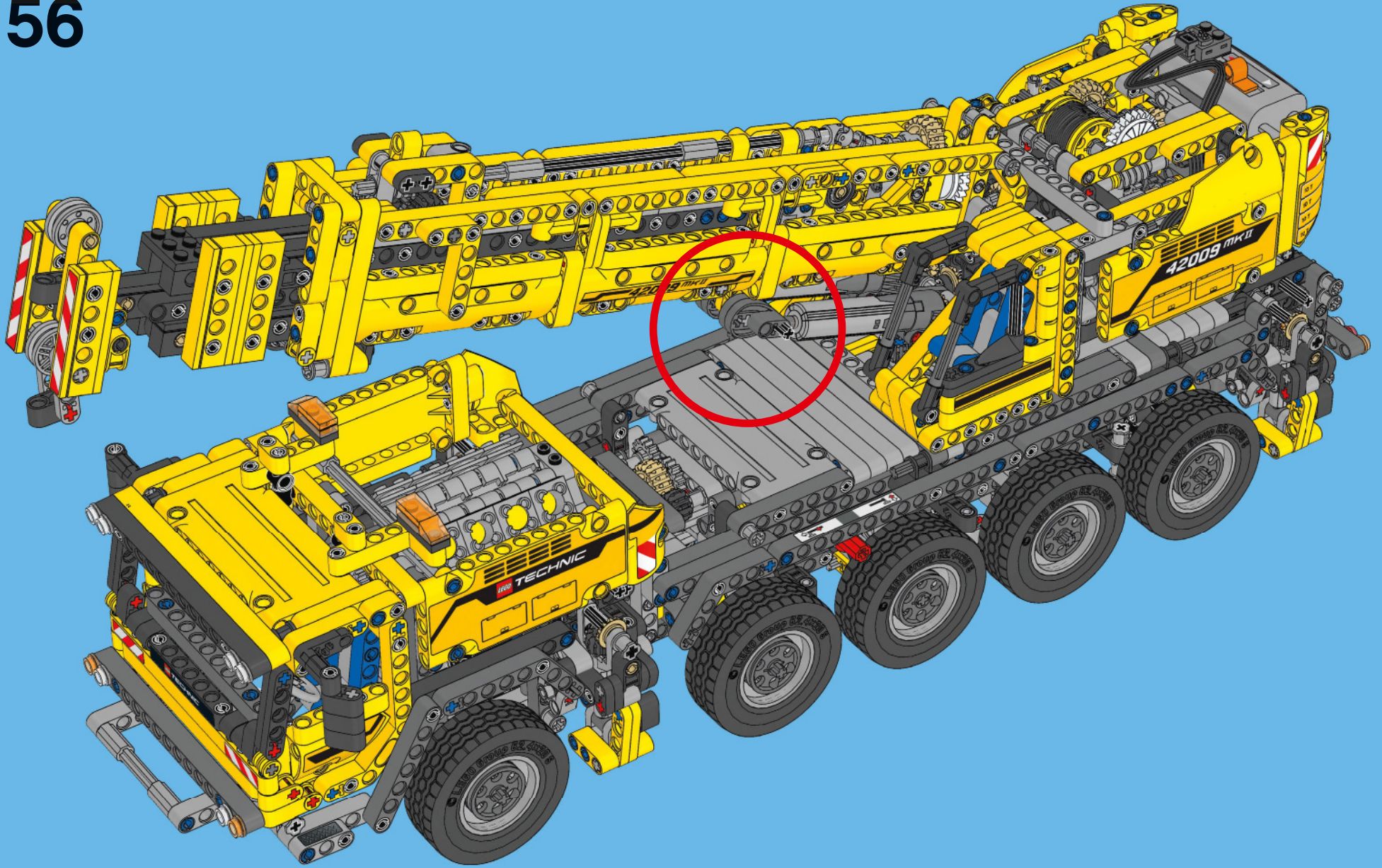



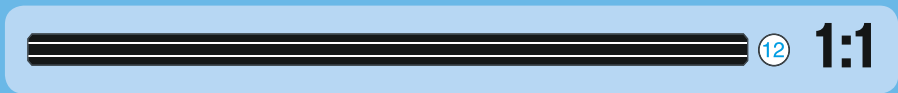
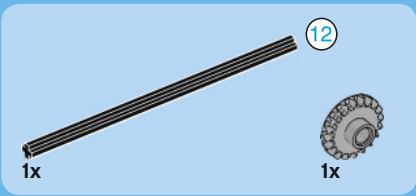

57

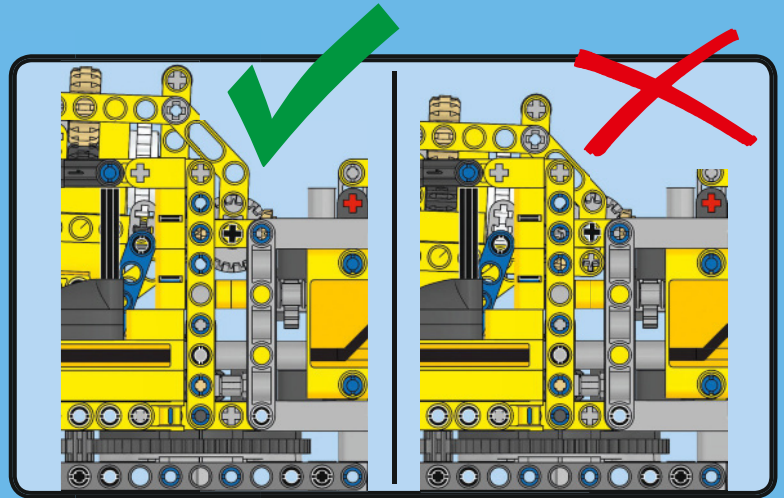



58

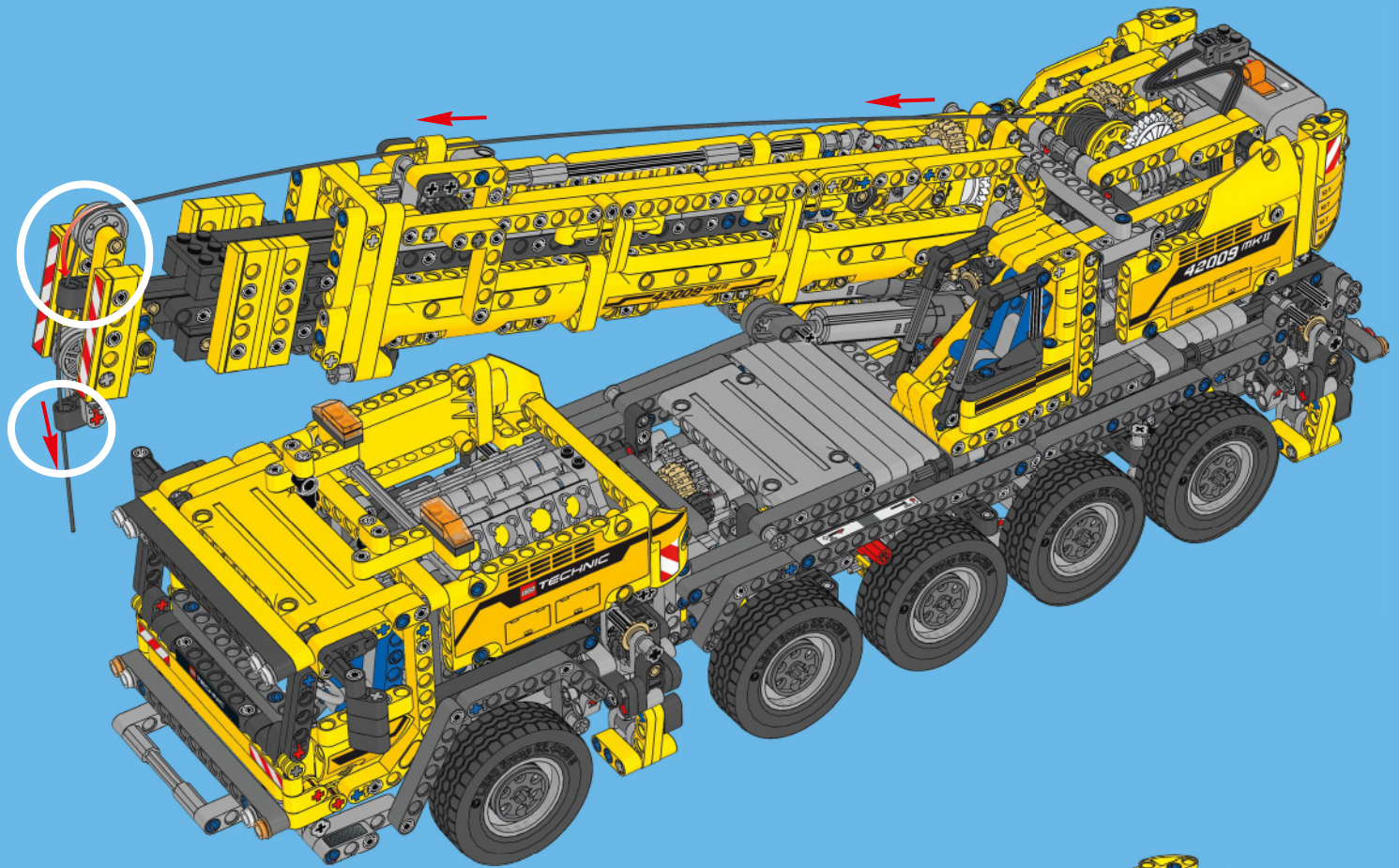

59

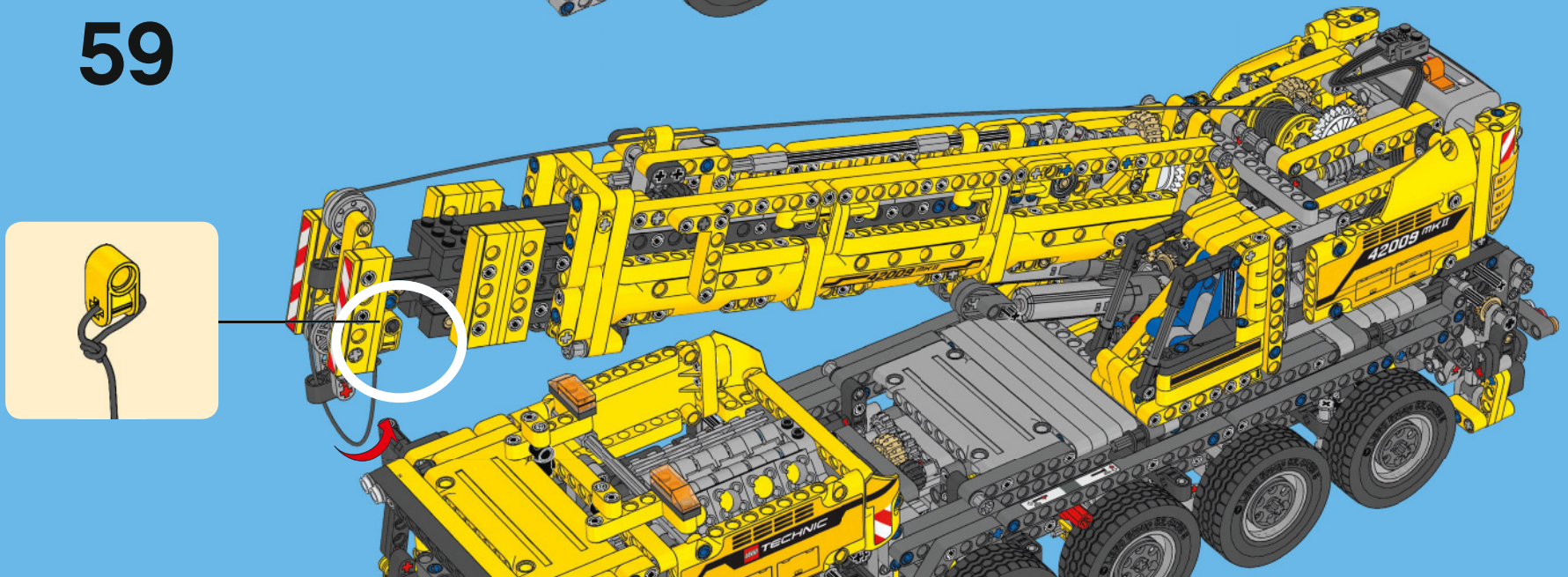

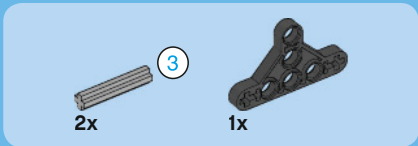
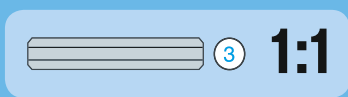
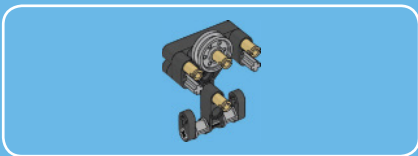

1

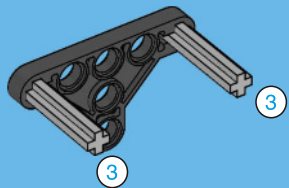

2

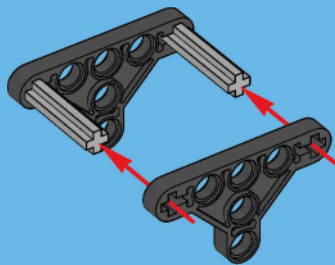

3

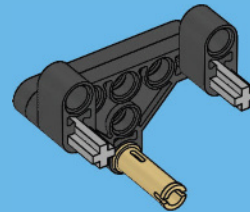

4

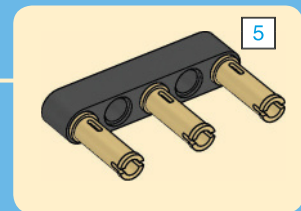
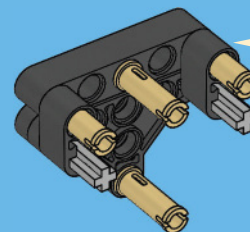
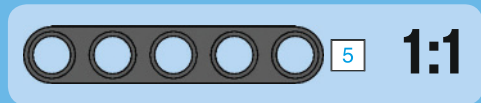





1x

# 5

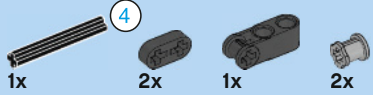
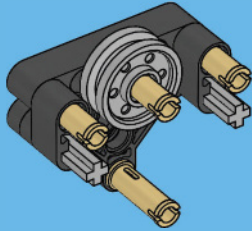

# 6

1

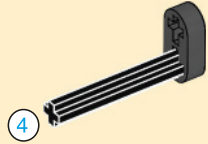

2

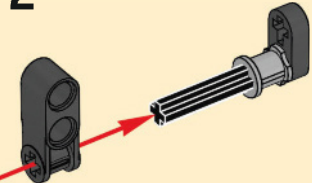

3

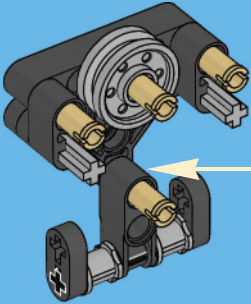
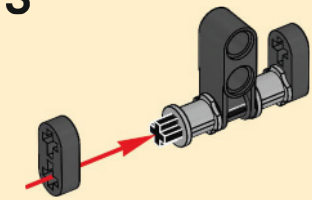

# 60

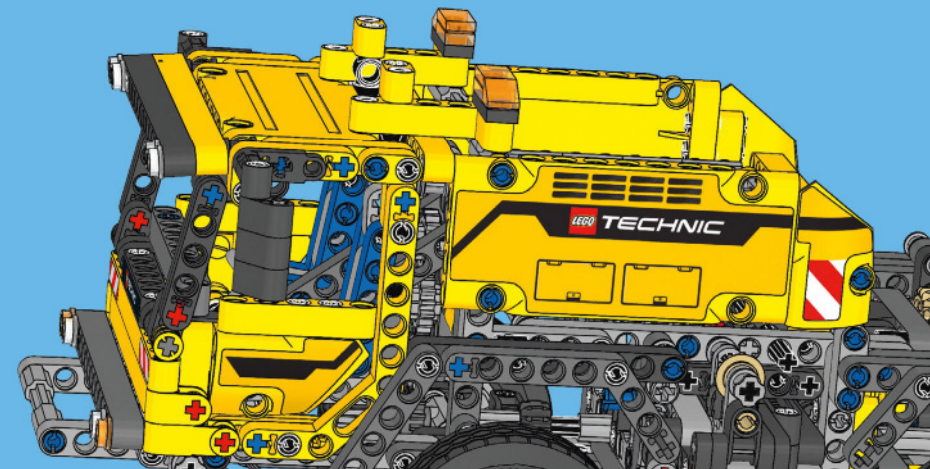
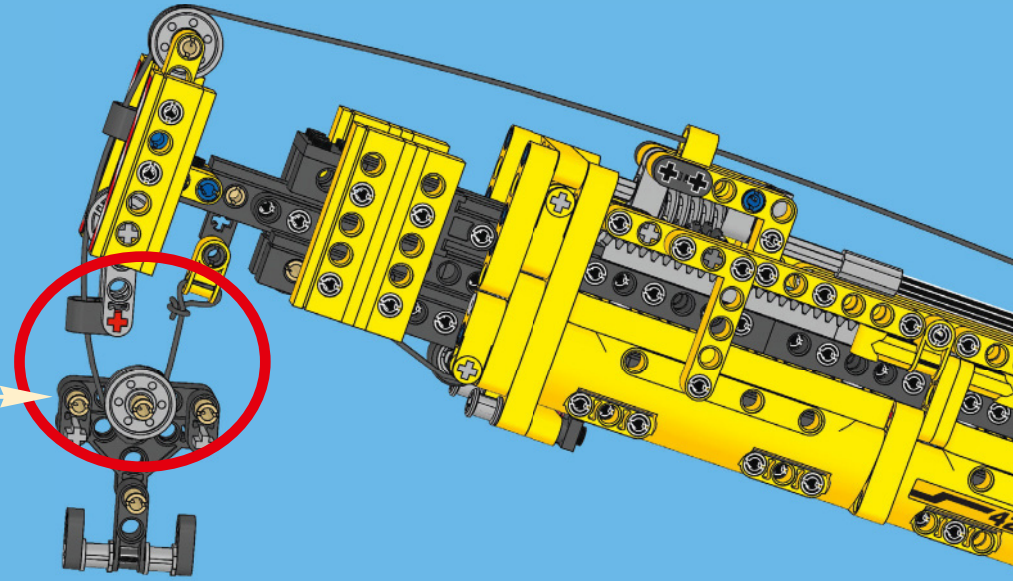



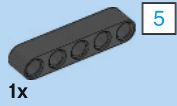

1x



5

1:1

# 61

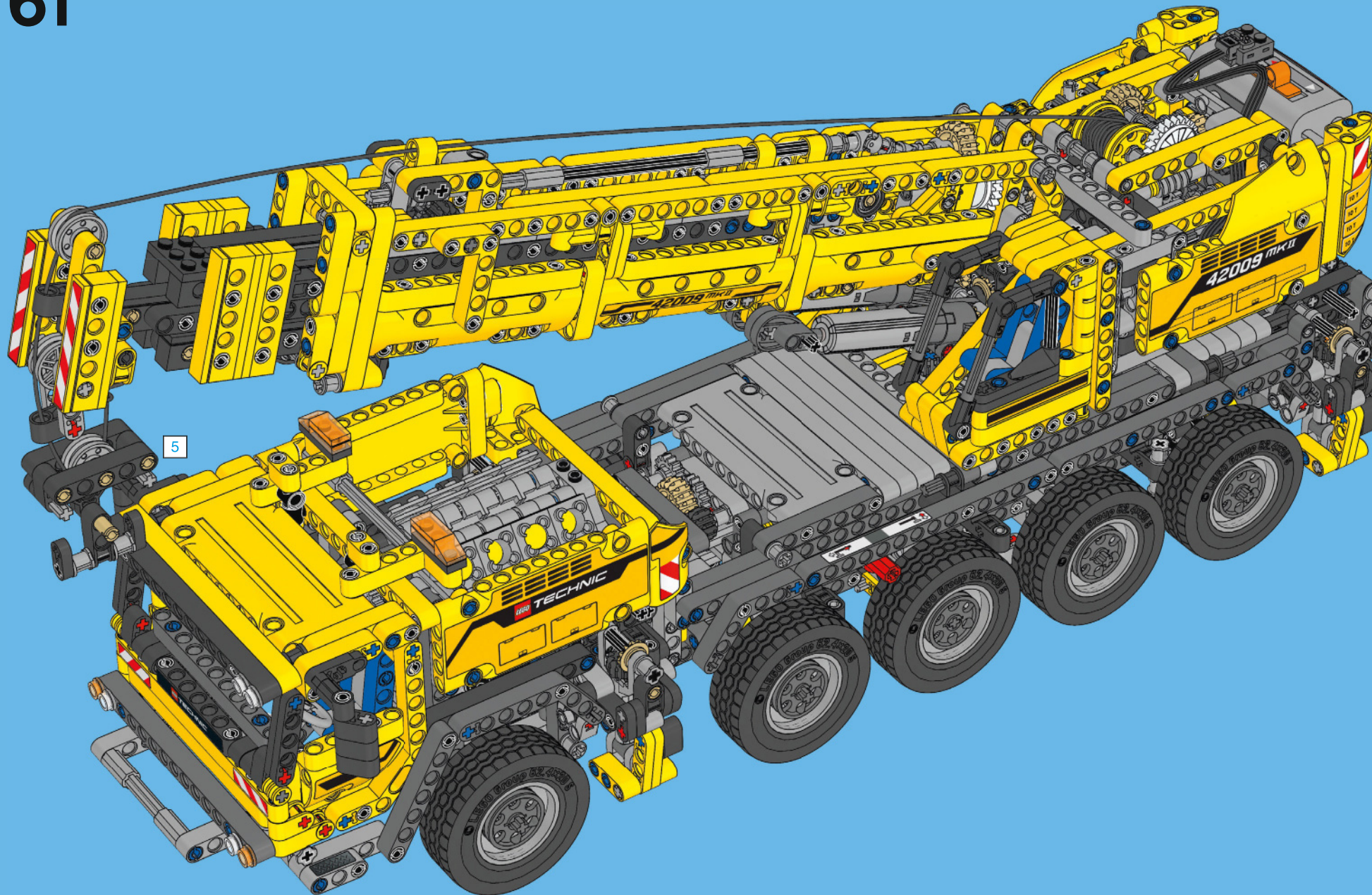



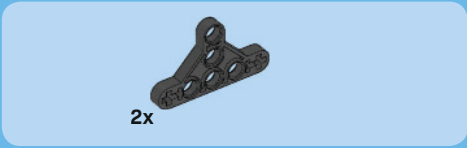

62

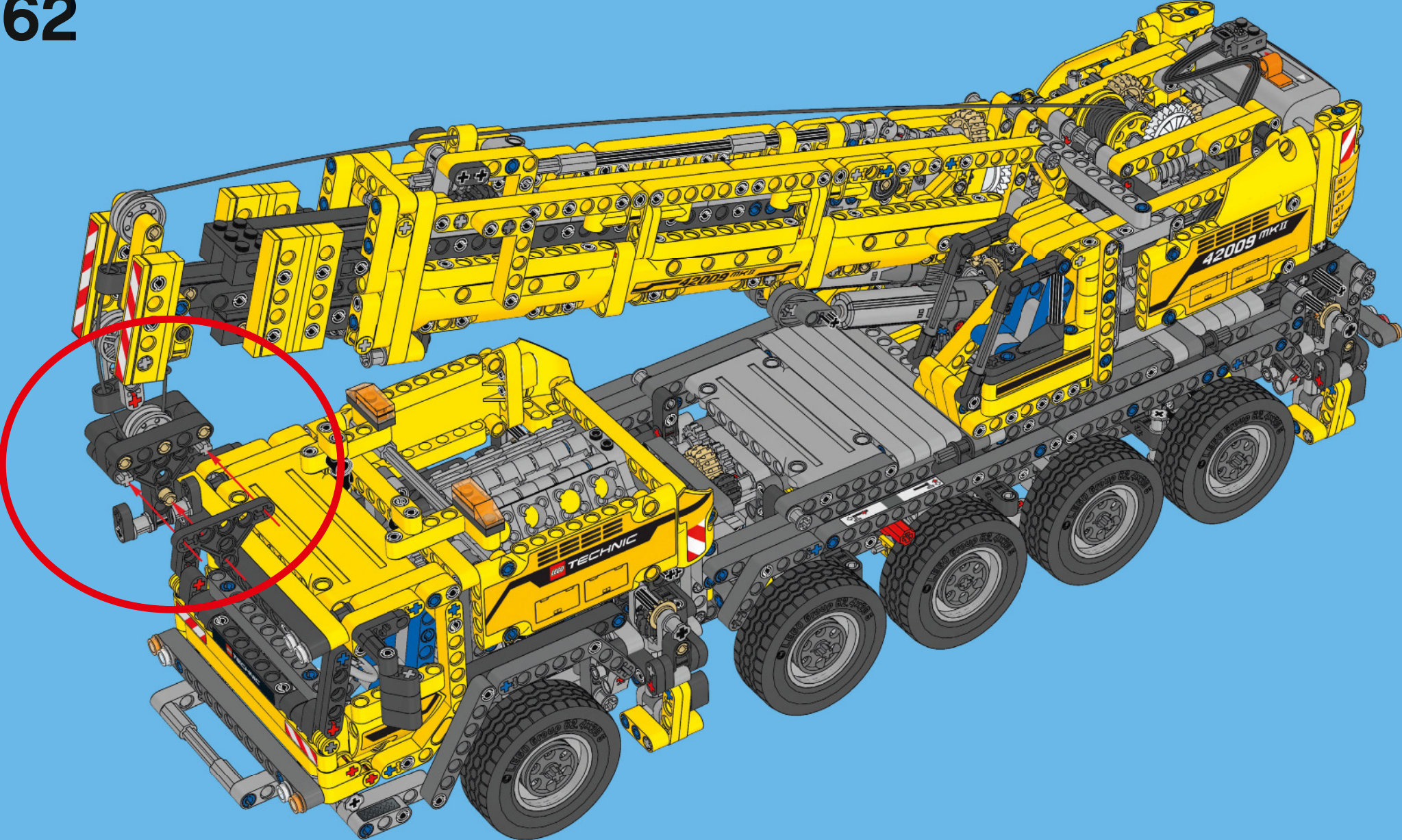



63

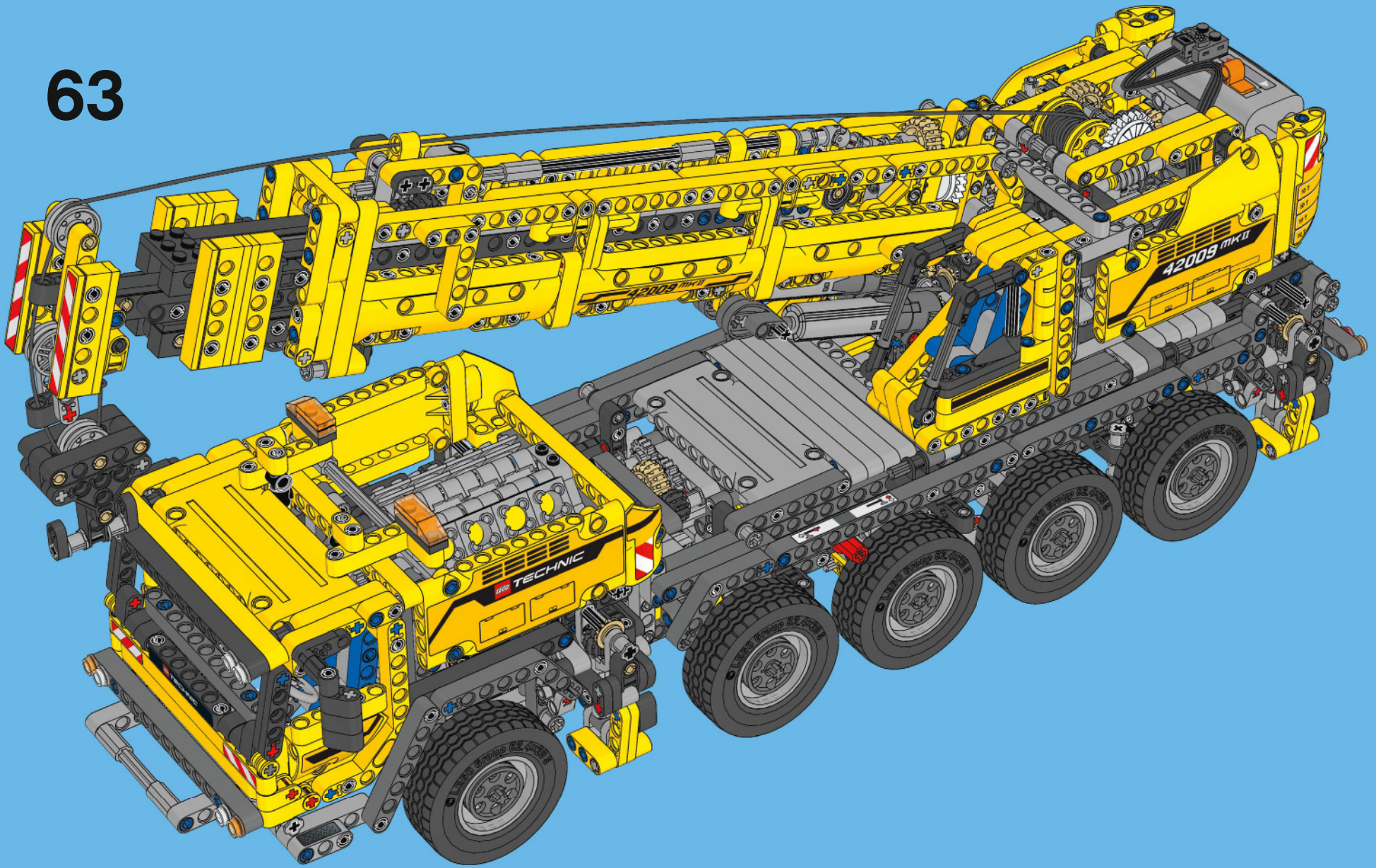



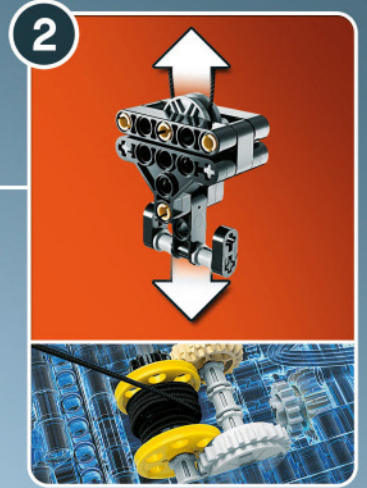
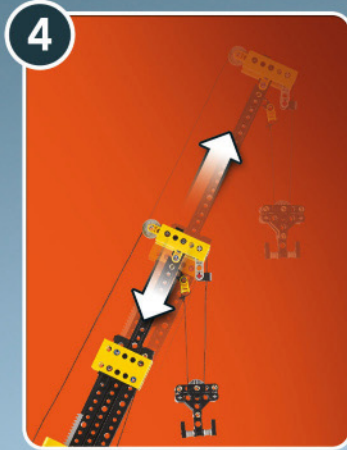





3

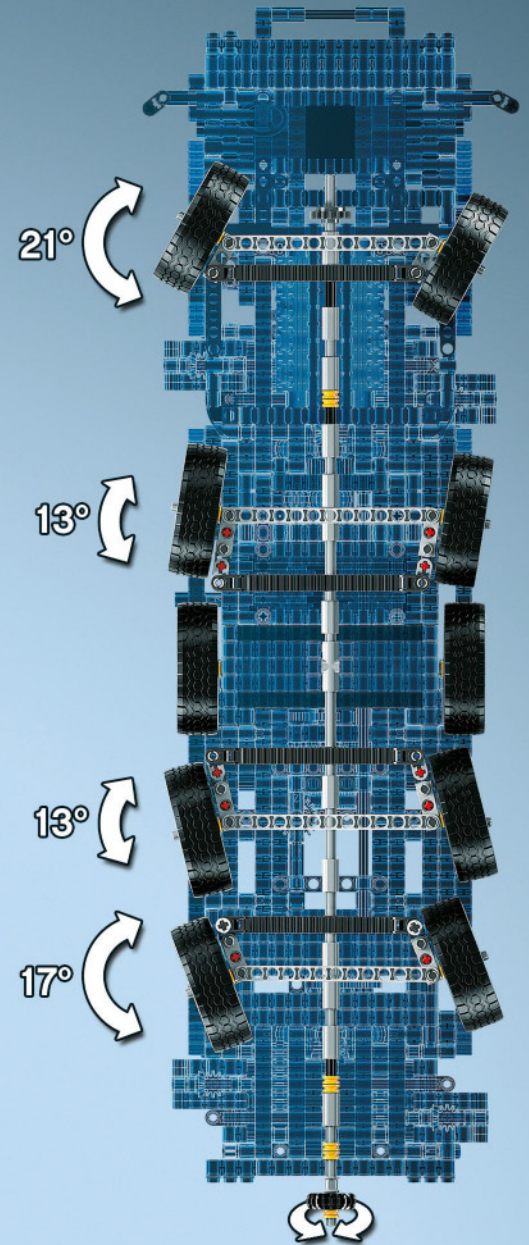
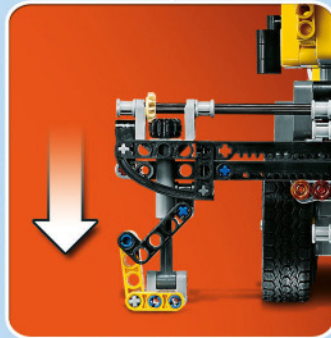
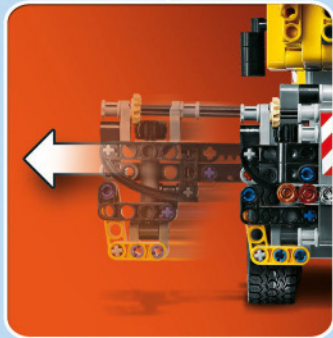





# TECHNIC



42008



42006



42000





# TECHNIC



2合1



This building instruction only at:  
**LEGO.com/technic**

Bauanleitung für das Modell nur auf:  
Ces instructions de montage uniquement sur:  
Sólo encontrarás estas instrucciones de construcción en:  
Instruções de construção só em:  
Ez az építési útmutató csak itt:  
此拼砌说明仅见于:

**LEGO.com/technic**



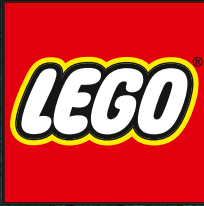

# TECHNIC







# club™

## Free\*! Gratuit !

\* Paid subscription in Australia and New Zealand.  
Abonnement payant en Australie et Nouvelle-Zélande.



# LEGO.com/club





# WIN!

Go to [LEGO.com/productfeedback](http://LEGO.com/productfeedback) to fill out a survey for a chance to win a cool LEGO® Product. No purchase necessary. Open to all residents where not prohibited.



## LEGO.com/productfeedback

### GEWINNE!

Nimm an der Umfrage auf [LEGO.com/productfeedback](http://LEGO.com/productfeedback) teil und hab die Chance ein cooles LEGO® Produkt zu gewinnen!

Die Teilnahme am Gewinnspiel führt zu keinerlei Kaufverpflichtungen. Teilnahme in allen nicht ausgeschlossenen Ländern möglich.

### WIN!

Ga naar [LEGO.com/productfeedback](http://LEGO.com/productfeedback), vul een enquêteformulier in en maak kans op een cool LEGO® product.

Geen aankoopverplichting. Ledereen mag deelnemen, uitgezonderd ingezetenden van landen waar een enquêteverbod geldt.

### GAGNE!

Visite [LEGO.com/productfeedback](http://LEGO.com/productfeedback) pour répondre à un questionnaire et avoir une chance de gagner un produit LEGO® très cool!

Aucune obligation d'achat. Ouvert à tous les résidents des pays autorisés.

### 当てよう!

[LEGO.com/productfeedback](http://LEGO.com/productfeedback) にアクセスして、アンケートにご記入ください。当選者にはレゴ製品を差し上げます。

お買い上げの必要はありません。禁止されていない限り、すべての皆様にご利用いただけます。



[LEGO.com](http://LEGO.com)